

Readout for ESS Instruments

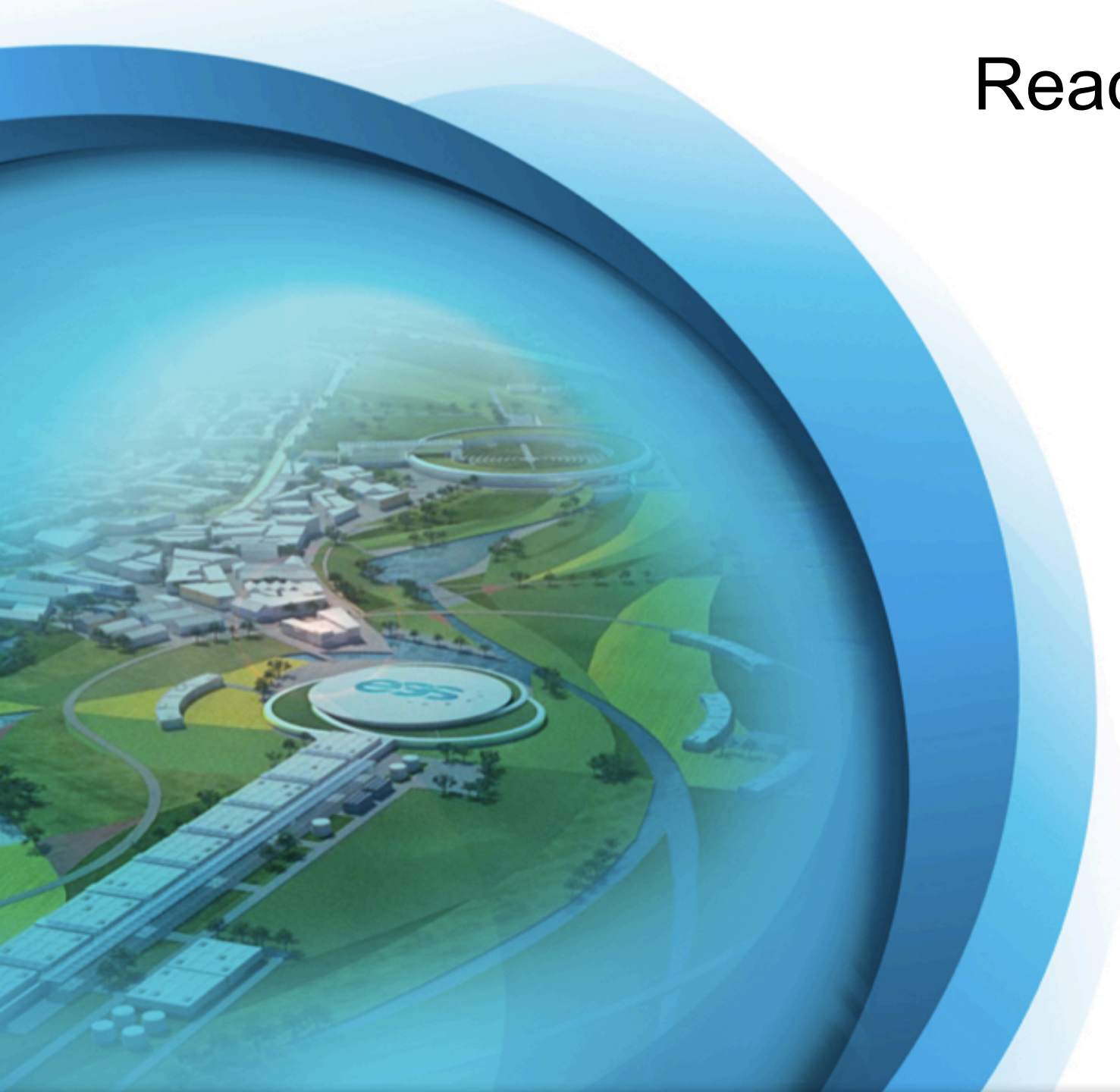

Scott Kolya
14th June 2013

Instruments

Instruments are made up of a number of subsystems.

While there will be similarities between some subsystems of some instruments, the collection and layout is unique (otherwise you wouldn't build it!!), and designed to perform specific measurements dictated by the science case.

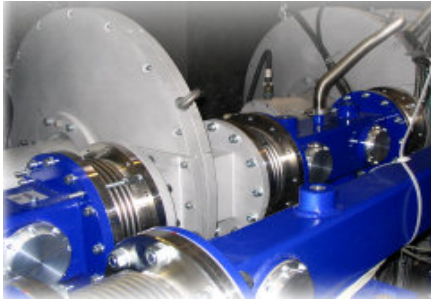

Choppers, Shutters
etc

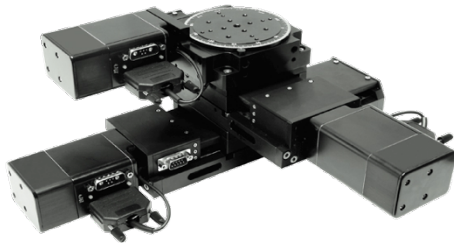

Sample Environment
and Control

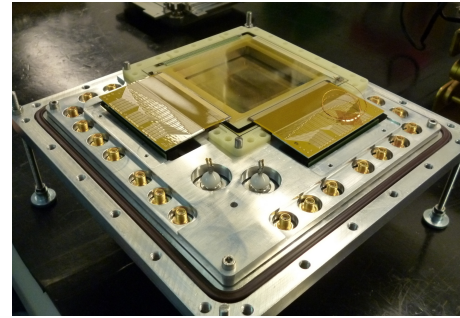

One or more types of
detector.

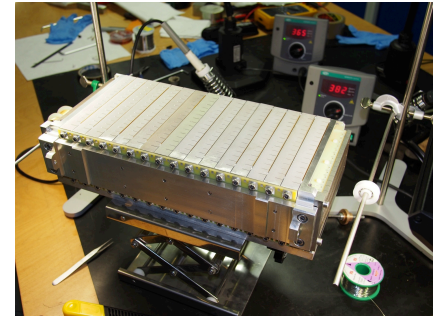

How Instruments Integrate into wider ESS systems (datawise)

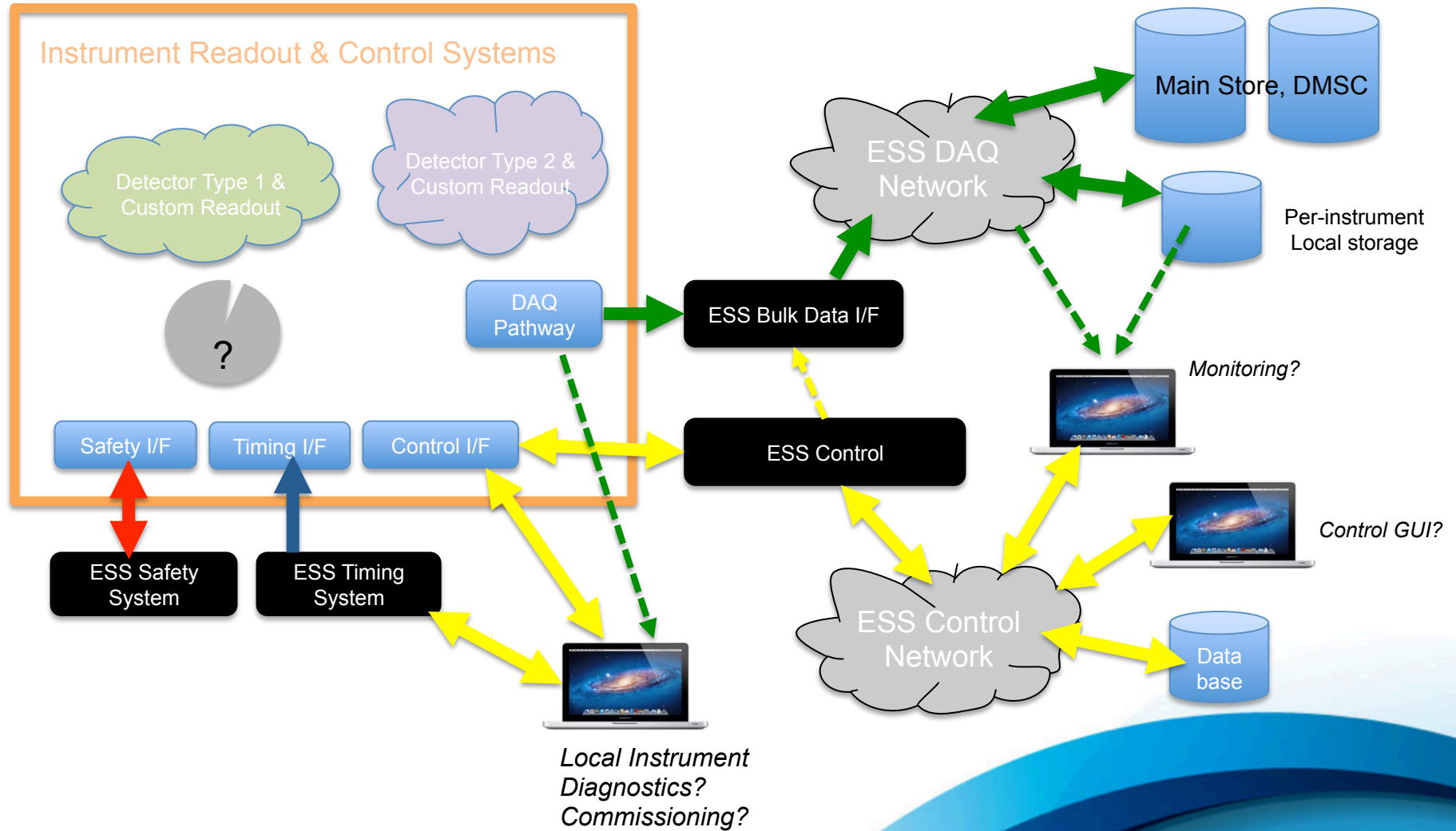

Control Domains

The accelerator (and target?) is a large system with many parts that must all work together => Integrated controls essential.

Each Instrument is essentially self contained, control needs are localized.

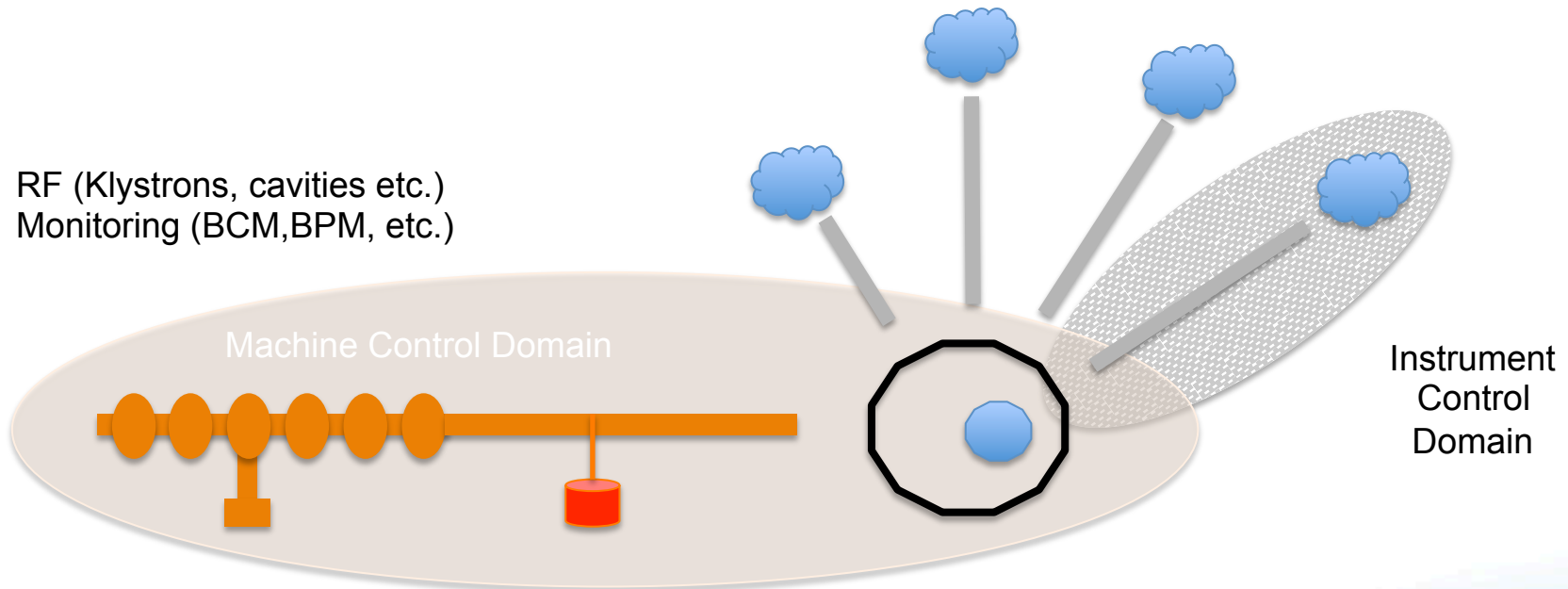

Q: Do the Instrument Control Systems have to match the Accelerator?

A: Probably not

Q: Is there any good reason for it not to match?

A: Again, probably not

Different elements are the responsibility of different groups at ESS

DG Detector Group (with in-kind external contributions)

EE Electrical Engineering, motion control, cryo control?, chopper servo, etc

ICS Integrated Controls, tie everything together

Instrument Element	Local Group	Source	Implementation Standard
Beam – Choppers, Shutters etc	EE	Bespoke	Likely to be standard across ESS
Sample - Motion Control etc	EE	COTS	Likely to be standard across ESS
Sample - Magnet	??	??	Likely to be standard across ESS
Sample - Cryogenics	??	??	Almost certainly standard at ESS
Detector HV, BIAS etc.	DG/ICS External	COTS	Usually standard system
Detector Gas	DG/ICS	Bespoke	Almost certainly standard at ESS
Detector Readout	DG External	Bespoke	Likely to be a mix of systems

READOUT (detector subsystem)

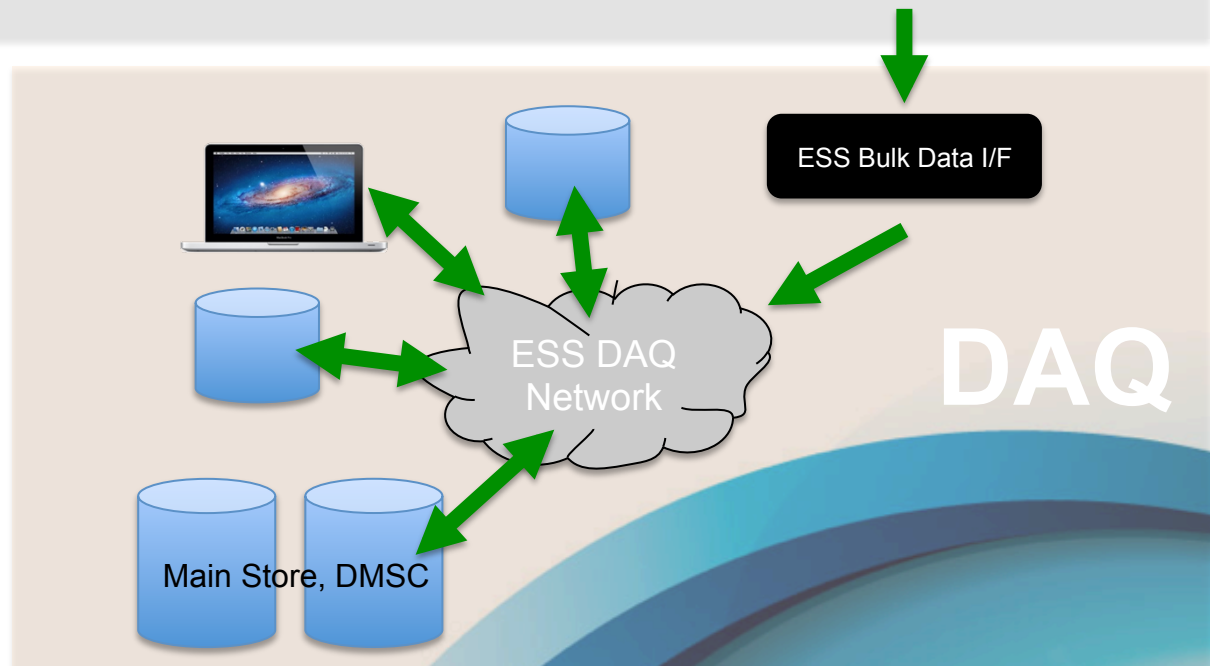
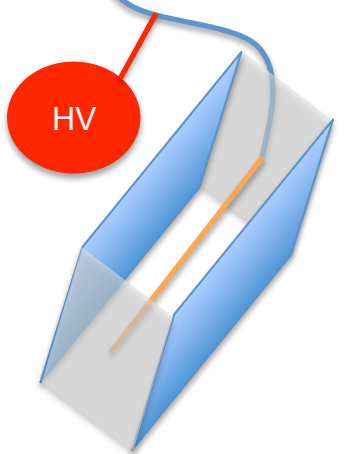
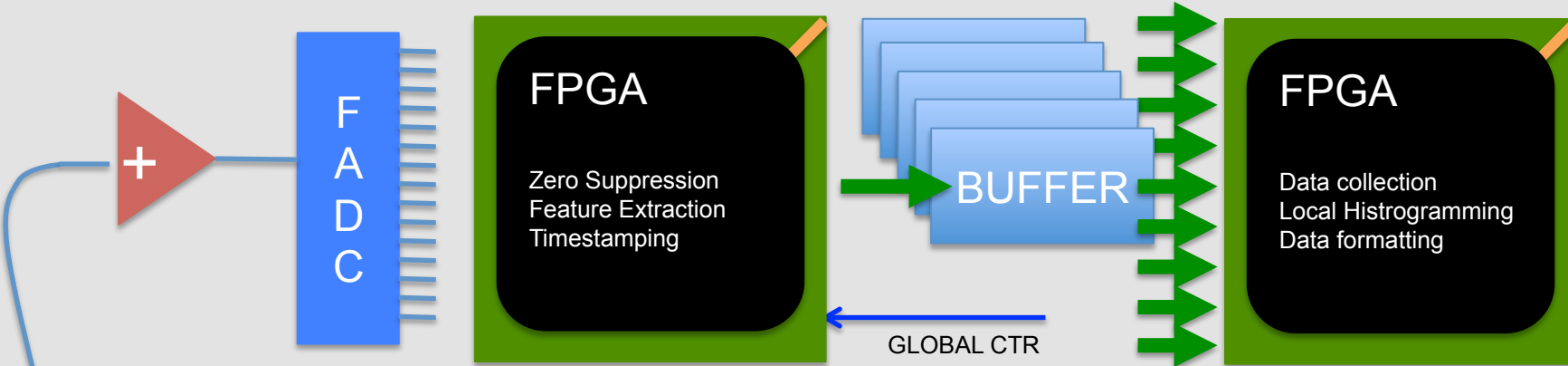
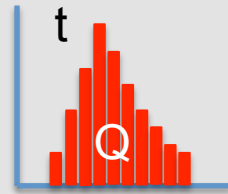

ESS Instrument Model

Menu approach to building instruments – a collection of independently operating sub-systems

Standardization of readout electronics increases as we get closer to interfaces.

An instrument will have one or more detector systems, each of which will have one or more subsystems

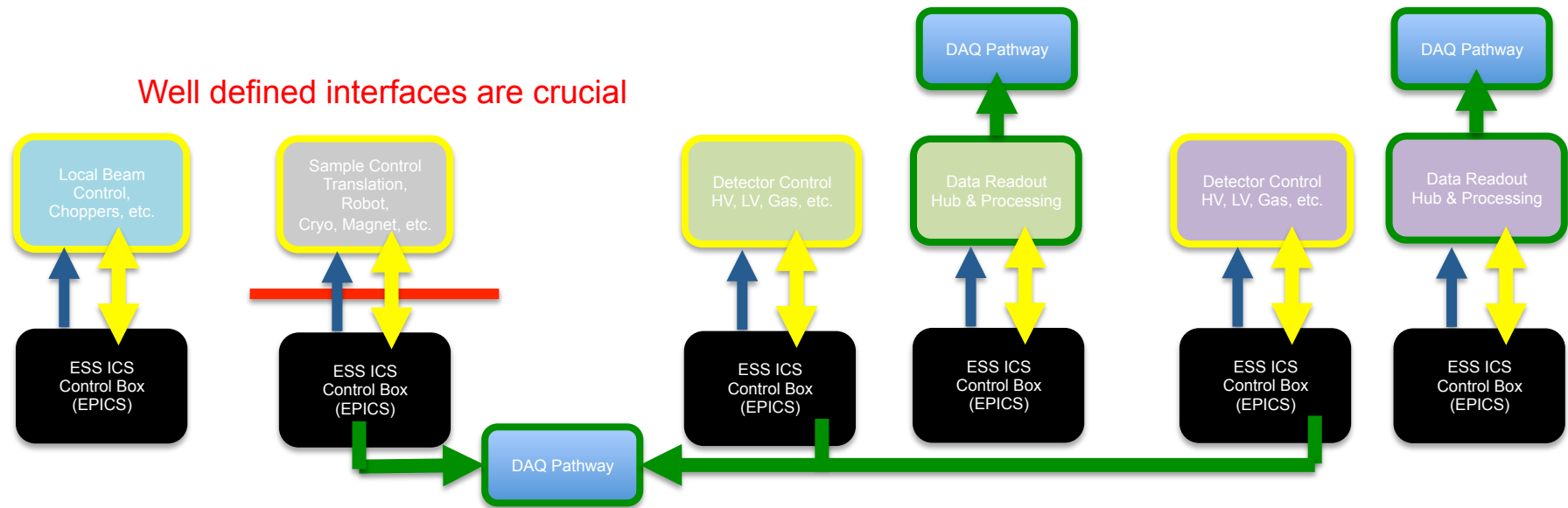

Logically one control box per subsystem (in practice can be combined)

Control data handled by EPICS

Propose: Smaller data volumes can also be collected via EPICS

Propose: Larger volumes of data require dedicated interface.

How do we connect to ICS?

EPICS is the basis ICS

Standard connection is a Control Box

Small number of varieties of Control Box

- cPCI
- μ TCA.4
- ...

Control Box is host to Timing Receiver (TR)

If a subsystem is COTS then the interface/driver probably already exists

Otherwise the subsystem team & ICS work together to implement an interface..

Control box (inc timing)

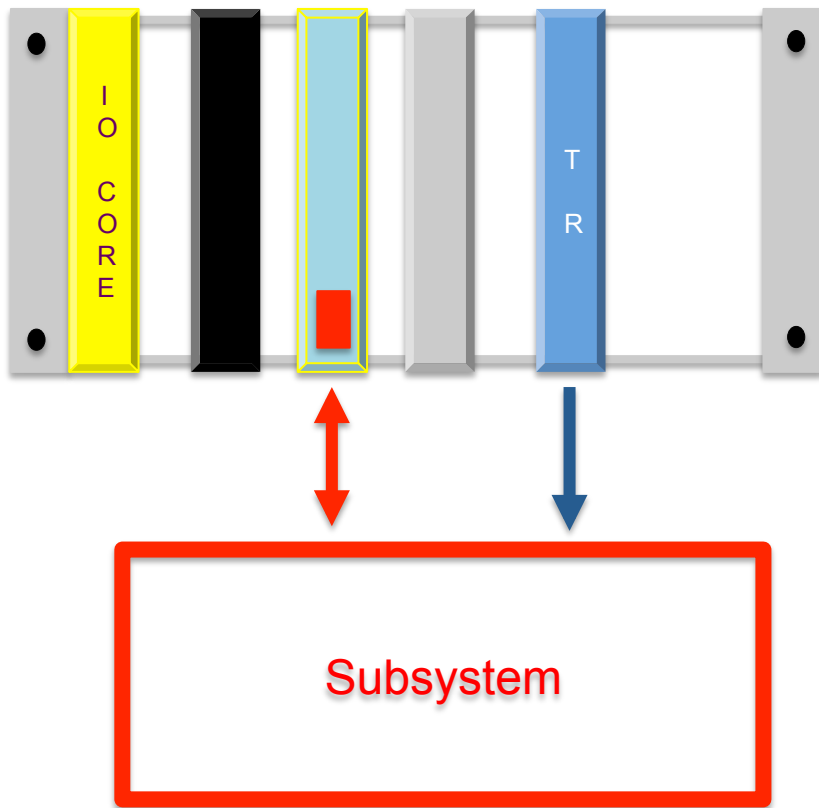

Most extended instrument data (cross communication etc) can go via EPICS.

Where totally unavoidable we allow for dedicated 'flying leads'.

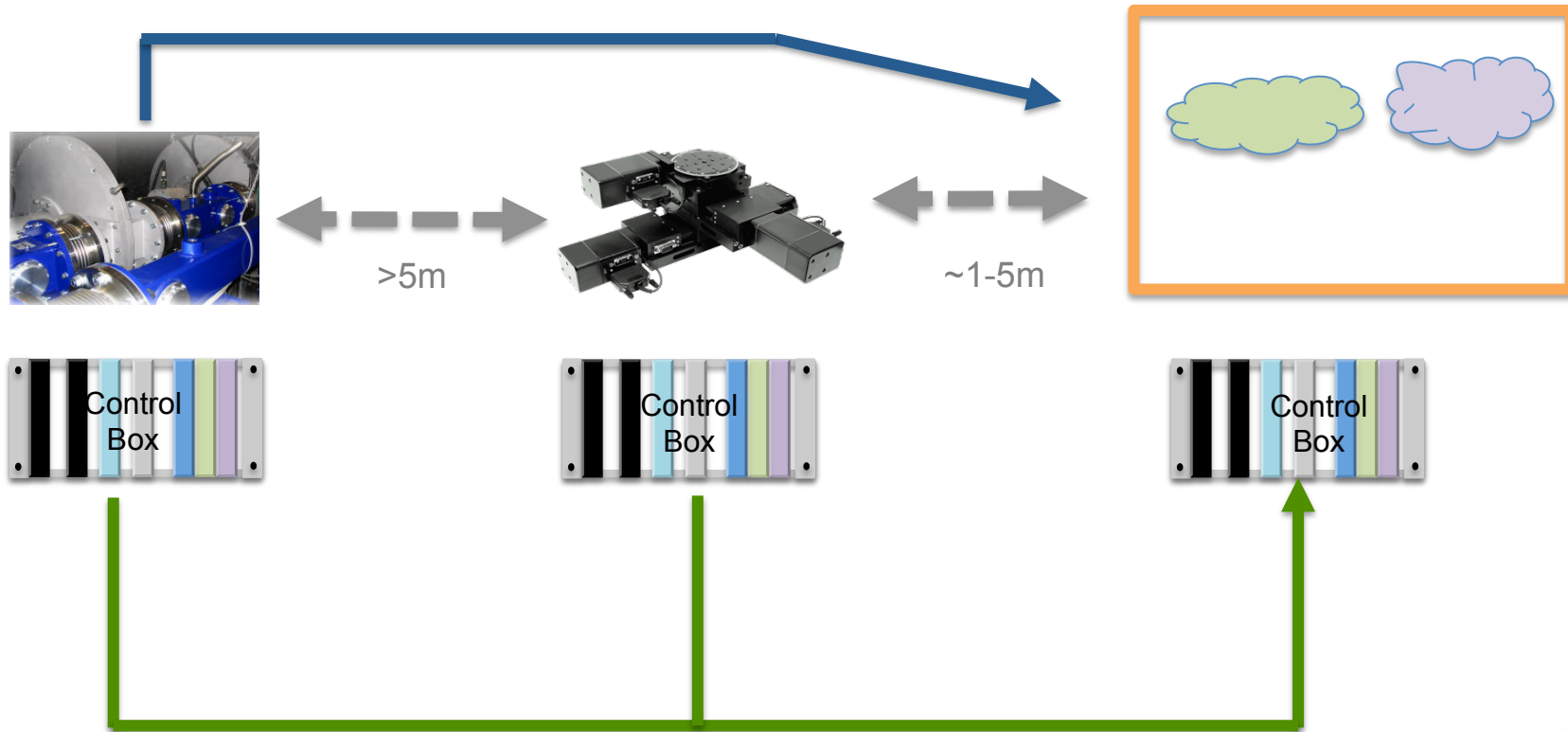

How detector readout interacts with ICS

- Interaction with control system minimal, with bursts of intense activity (change config)
- Shared memory interface, fixed locations and/or FIFO queue
- Some commands need to be synchronous, use hardware strobe from timing system to validate pre-loaded command word(s)

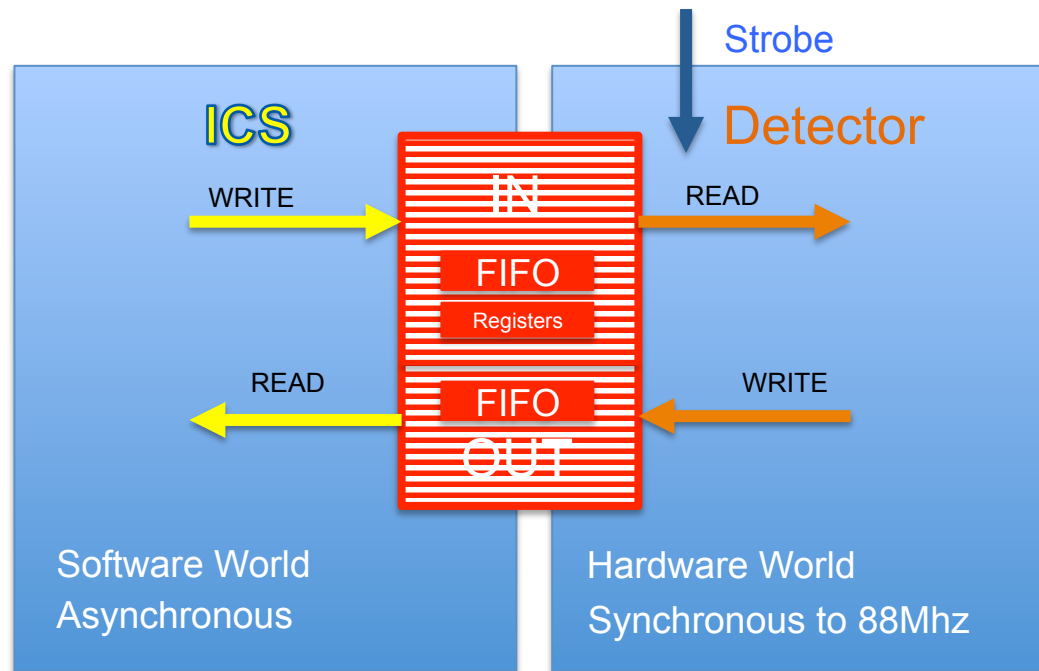

How we physically implement that...

- Inevitably, interface most likely to be implemented in an FPGA
- Could be a card in the control box, or standardized connection to card in detector master crate.
- Could also be embedded.
- Detector Group works with Controls Group to define and implement a small number of interfaces that should cover all instrument detector readout requirements.

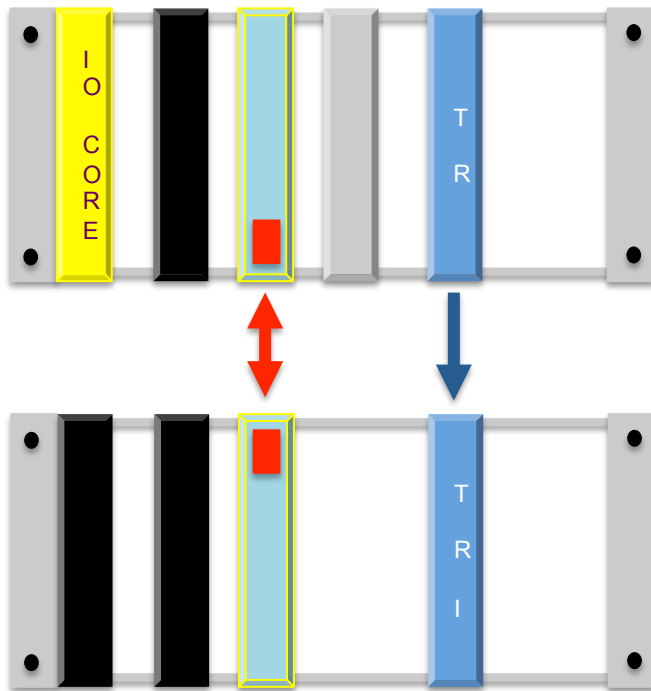

Detector Master Crate

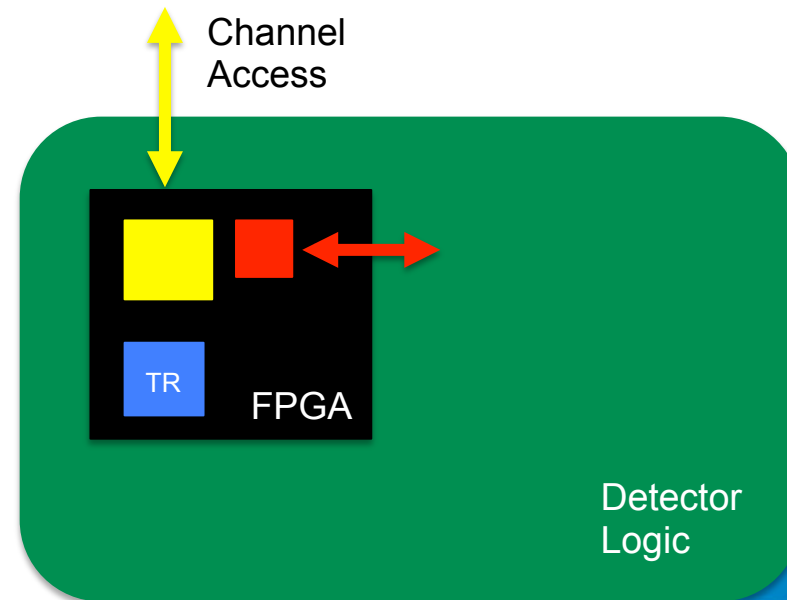

High bandwidth data connection

Simple push FIFO interface.

Detector subsystems sends data **in it's own optimal format (*proposal*)**

Flow control through ICS.

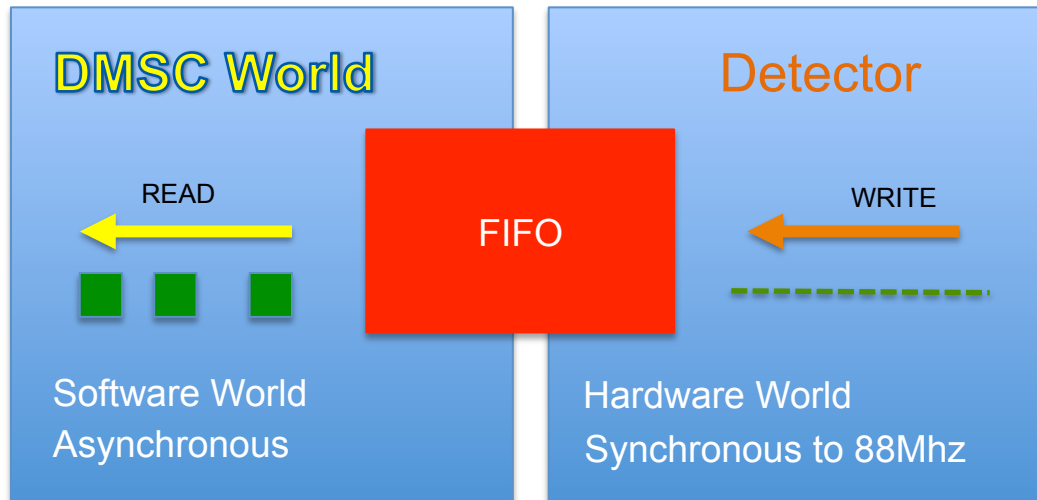

How we physically implement that (part1)

- Every subsystem has a control box - natural location for the data interface (*proposal*)
- Not dependent on control system, but some interaction might be useful (xon/xoff etc.)

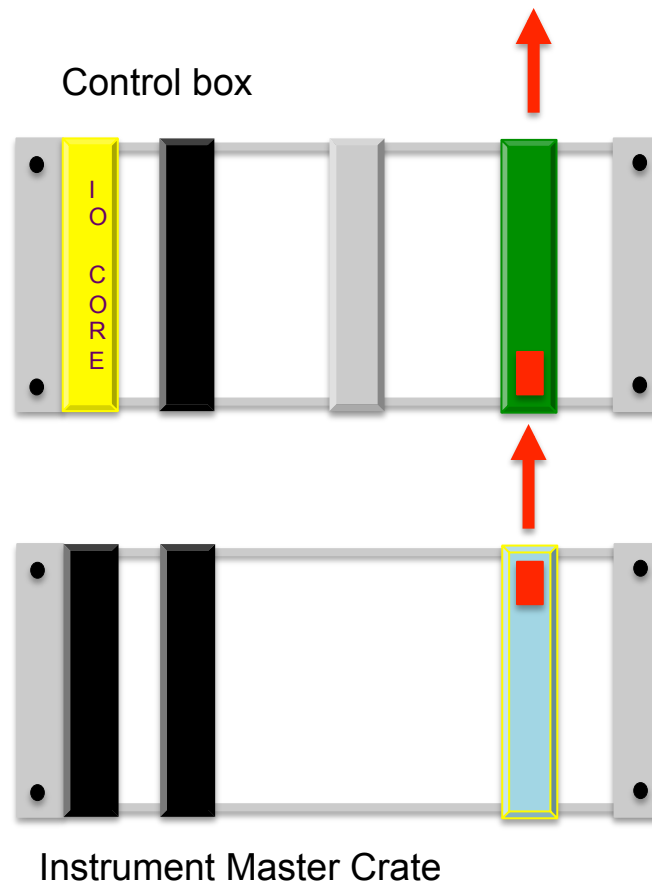

How we physically implement that (part2)

- Best to specify the interface at the connector or daughter-card level.
- Commercial FPGA carrier, COTS processor card etc act as host
- Actual location of FIFO unimportant, so long as both sides have access.
- Upgrade worst case – redesign the daughtercard.

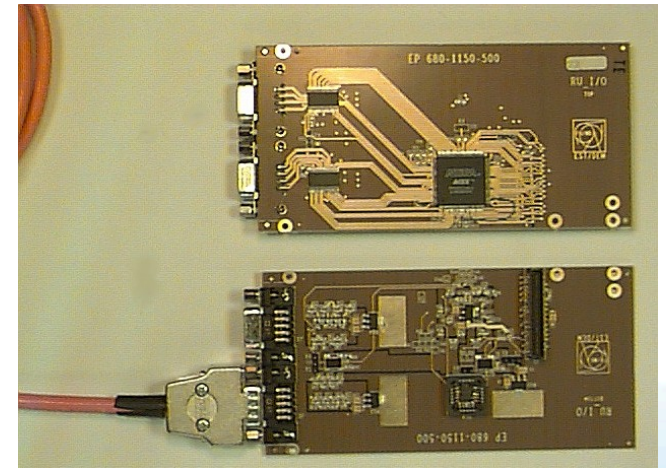
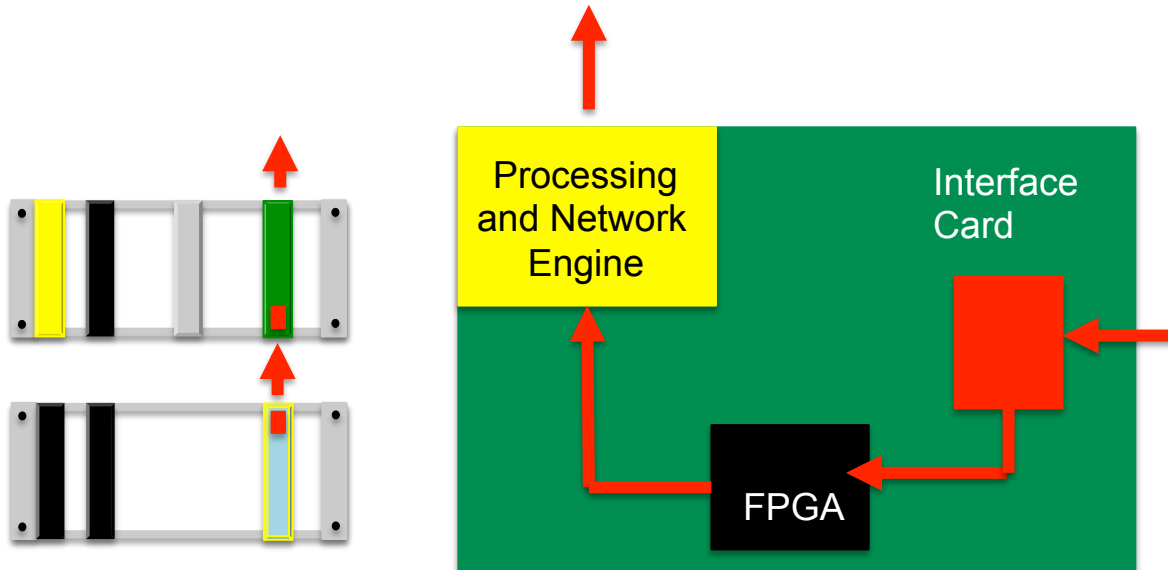

That sounds complicated, why don't you just use ethernet??

- Has to be a boundary somewhere Hardware world <-> Software World
- Want to isolate readout hardware from computing infrastructure upgrades
- Compare to modern Oscilloscope, hybrid of PC and custom logic.
- Detector readout electronics are expected to remain the same for the life of the instrument.



- We will also have private 'backdoor' communication channel(s).
- Used only by experts.
- Likely to be UDP direct to the FPGAs (standardize as far as possible)
- *We must have the facility to work standalone, prototyping, debugging, etc.*

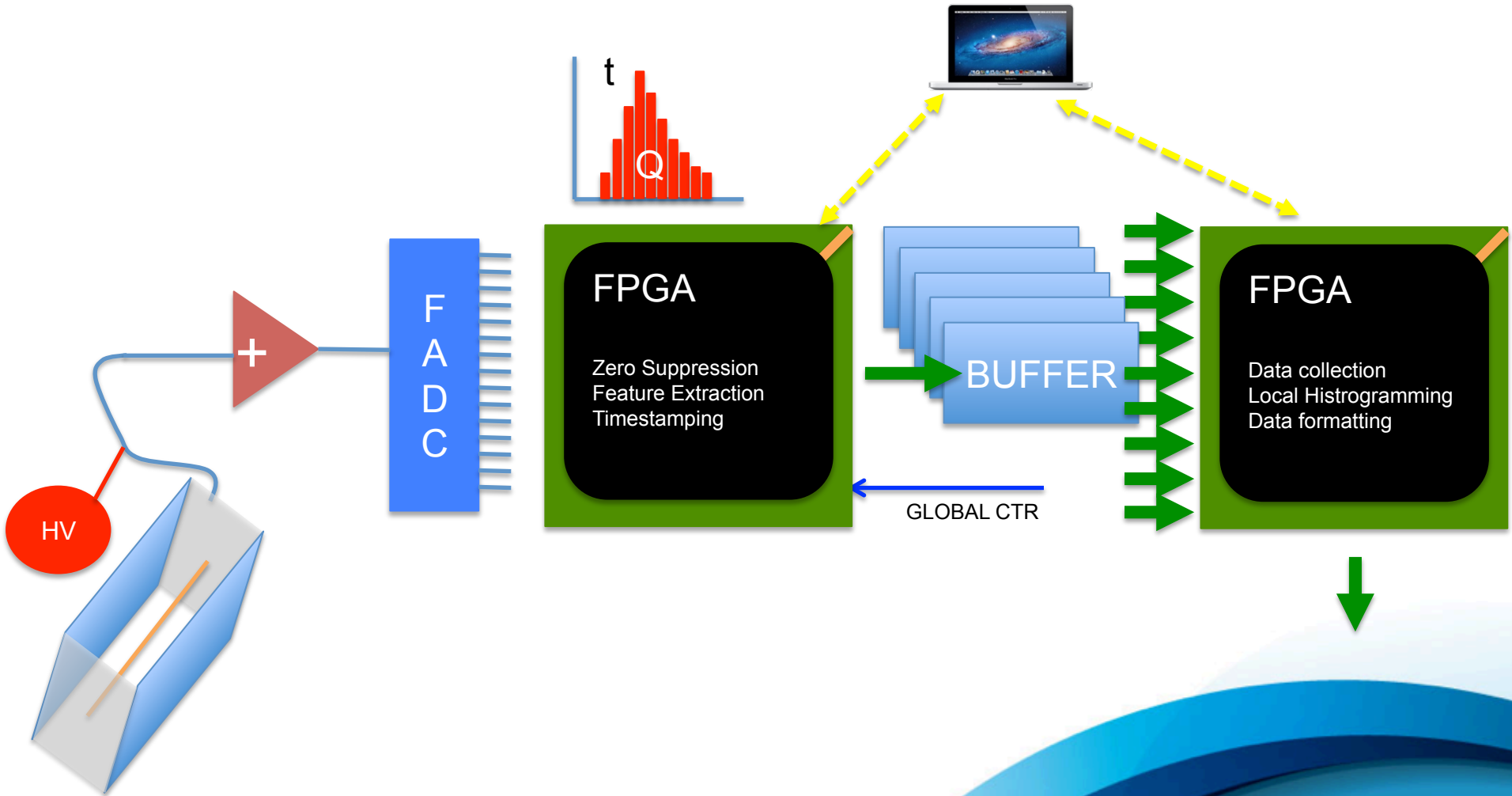

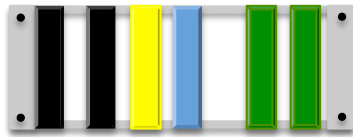

- Timing info (or fast control)
- Control info
- Recorded Data

Instrument Readout & Control Systems

Subsystem 1



Local Beam Control,
Choppers, etc.

Subsystem 2

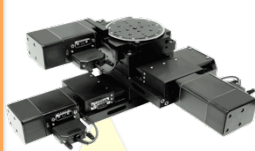

Sample Control
Translation, Robot,
Cryo, Magnet, etc.

Hub & Processing

Detector Type 1 &
Custom Readout

Detector Control
HV, LV, Gas, etc.

Hub & Processing

Detector Type 2 &
Custom Readout

Detector Control
HV, LV, Gas, etc.

XOFF

Local Data Store
Monitoring
Calibration
Onward Data I/F

DMSC

ESS Bulk Data I/F

Monitoring,
User GUI etc.

DMSC 'Scope'

ESS ICS
Control Box
(EPICS)

ESS ICS
Control Box
(EPICS)

ESS ICS
Control Box
(EPICS)

ESS ICS
Control Box
(EPICS)

ESS ICS
Control Box
(EPICS)

ESS ICS
Control Box
(EPICS)

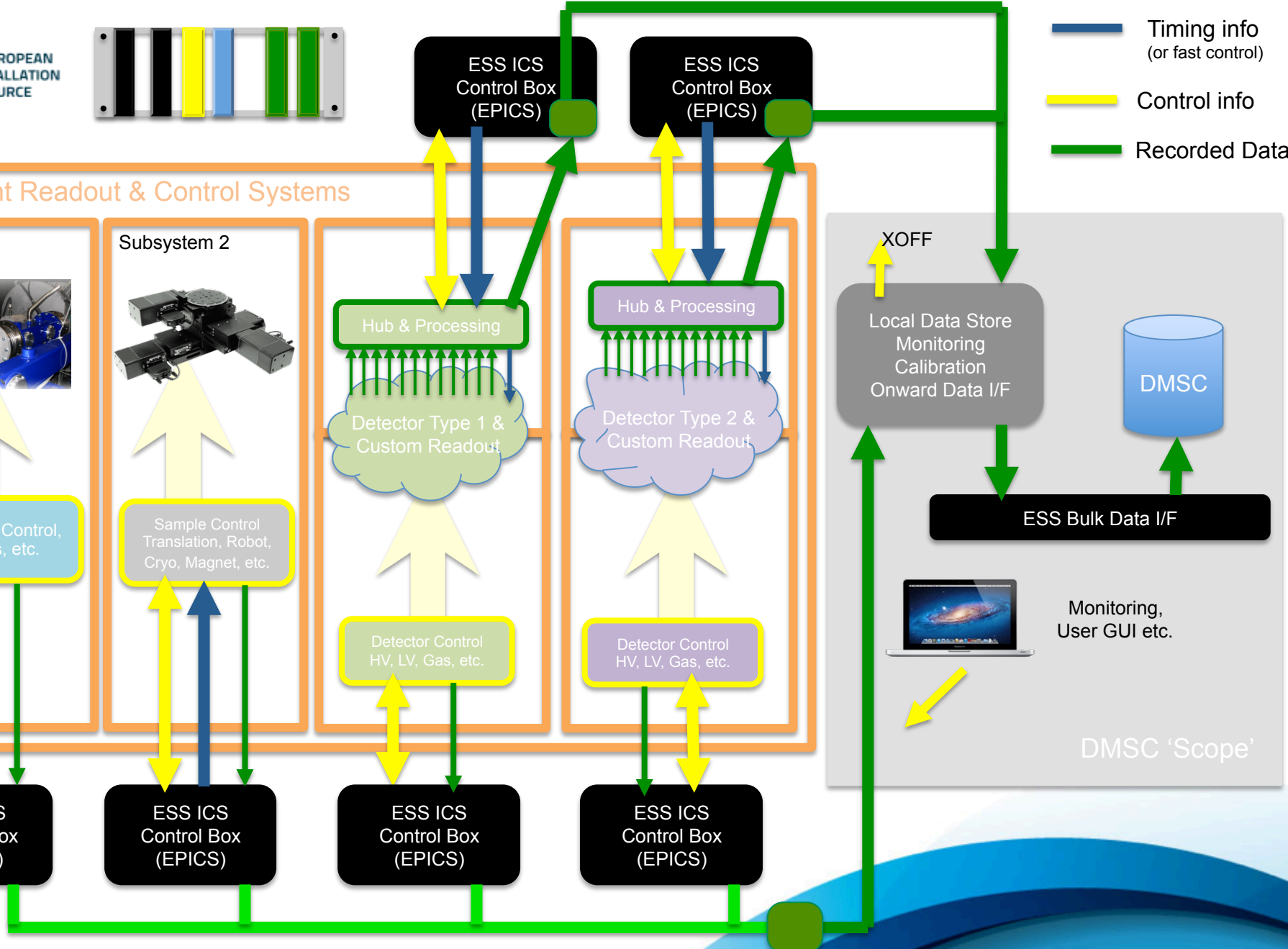

- Data compression in front end needs to be monitored
- Monitoring data to be dumped periodically, or on demand
- Special calibration modes may be needed

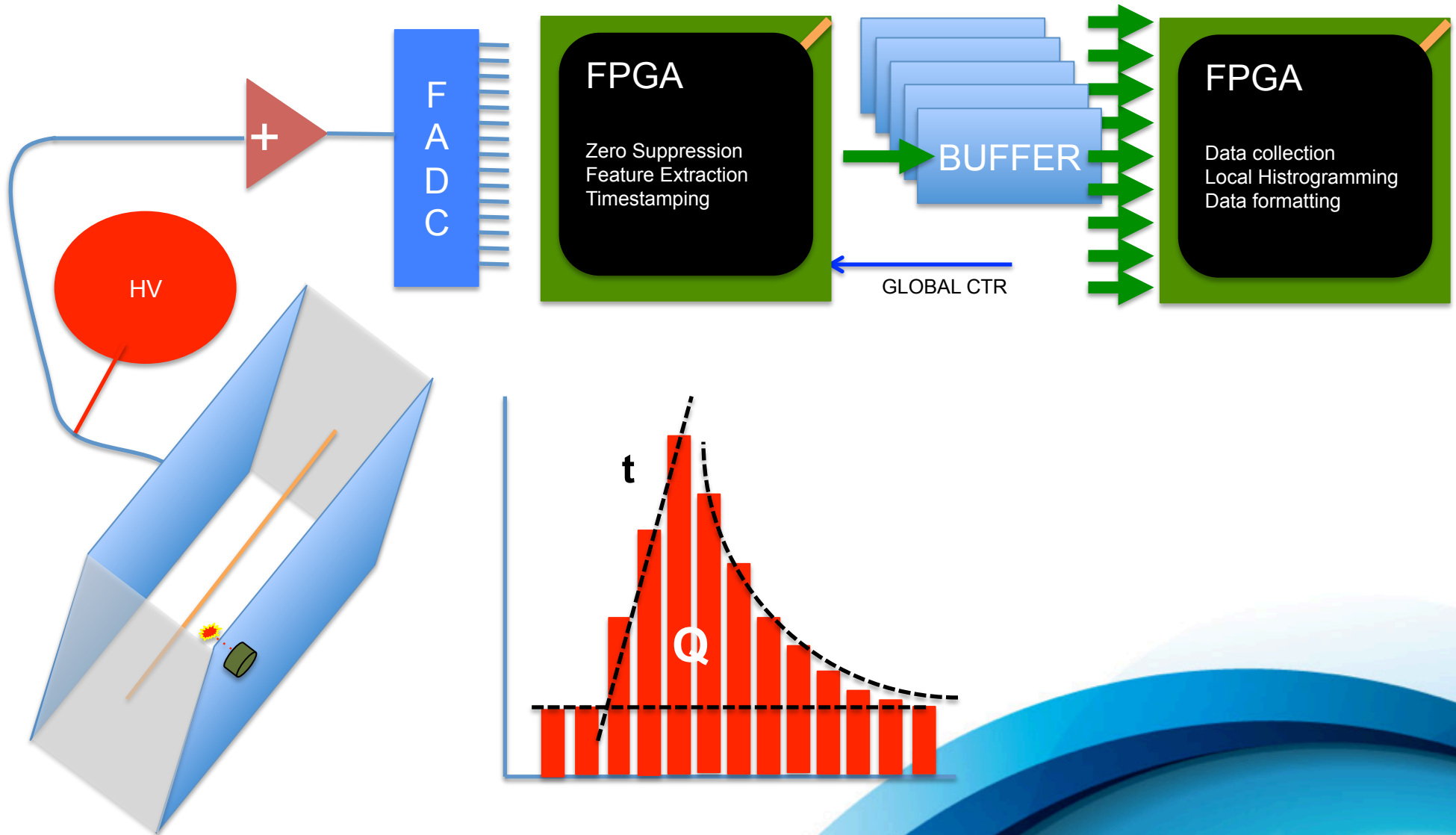

Calibration Cycle

*Database location decision
needed from this meeting*

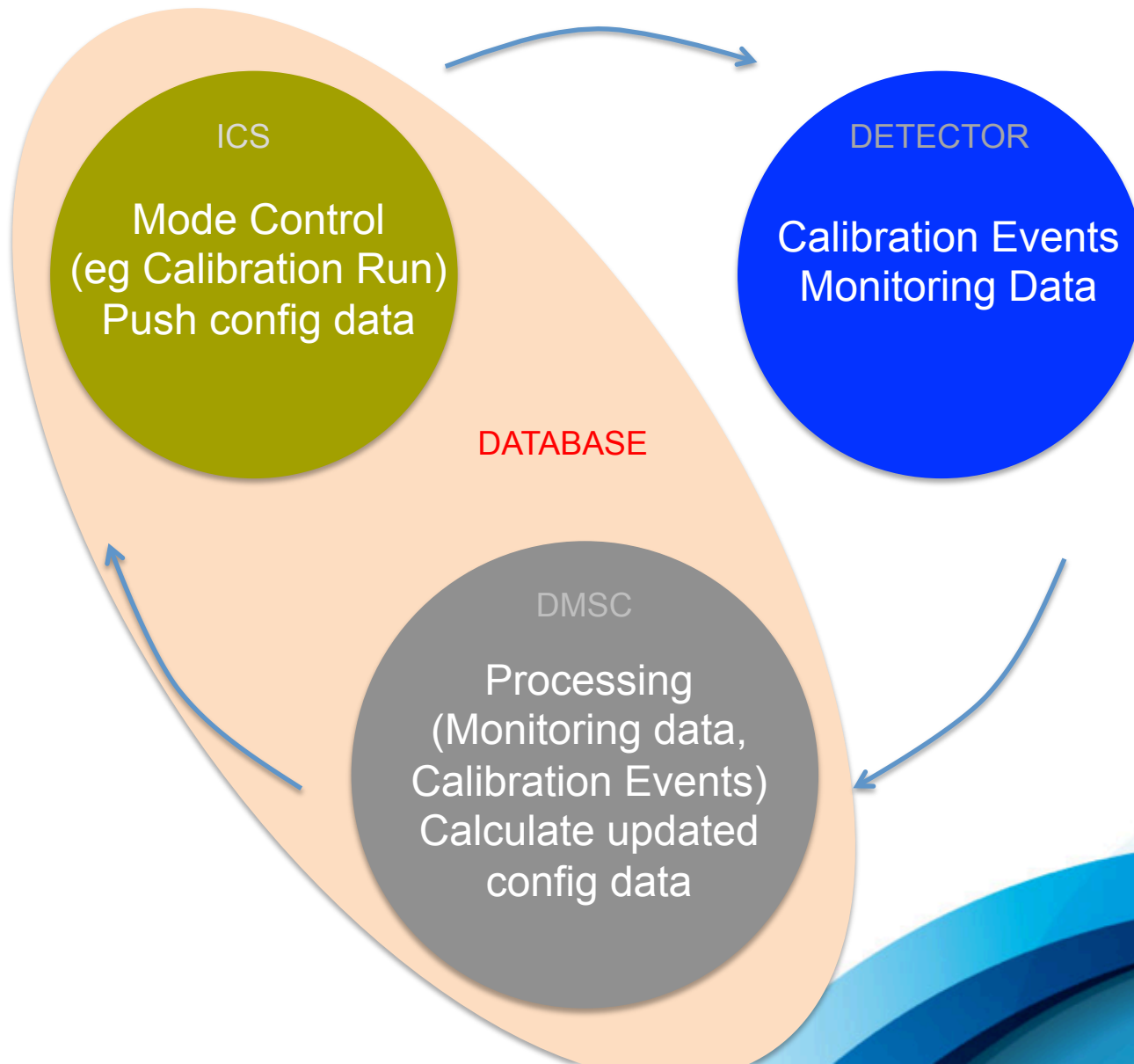

Detector Group Readout Integration Responsibilities

- Collaborate with Controls on interface hardware
- Collaborate on design of bulk data interface hardware
- For each detector subsystem
 - Specify command set, control variables, config tables, etc.
 - Specify data output format
 - Define an appropriate monitoring strategy
 - Provide algorithms for DMSC monitoring processing where necessary
 - Define an appropriate calibration strategy
 - Provide algorithms for DMSC calibration processing where necessary
 - Provide expert diagnostic tools with independent access that can be used to debug these interfaces.

External Detector Elements

In kind contributions
Commercial systems

DETECTOR GROUP

Readout & Data pre-processing (compression etc)
Detector specific monitoring

Control Specification
Control Hardware

Data Output Format
Data Processing Algorithms

Local Data Logging
Remote Data Logging
Instrument Level Monitoring
User interaction GUI

LINK
HARDWARE
DATABASE

Control Network
CONTROLS

Control Interface
Data Collection

DMSC