



Elettra Sincrotrone Trieste

# ***The ESS Wire Scanner EPICS IOC***

Stefano Cleva

*Elettra Sincrotrone Trieste*

## Original plot of the block diagram (since PDR2) ... still valid

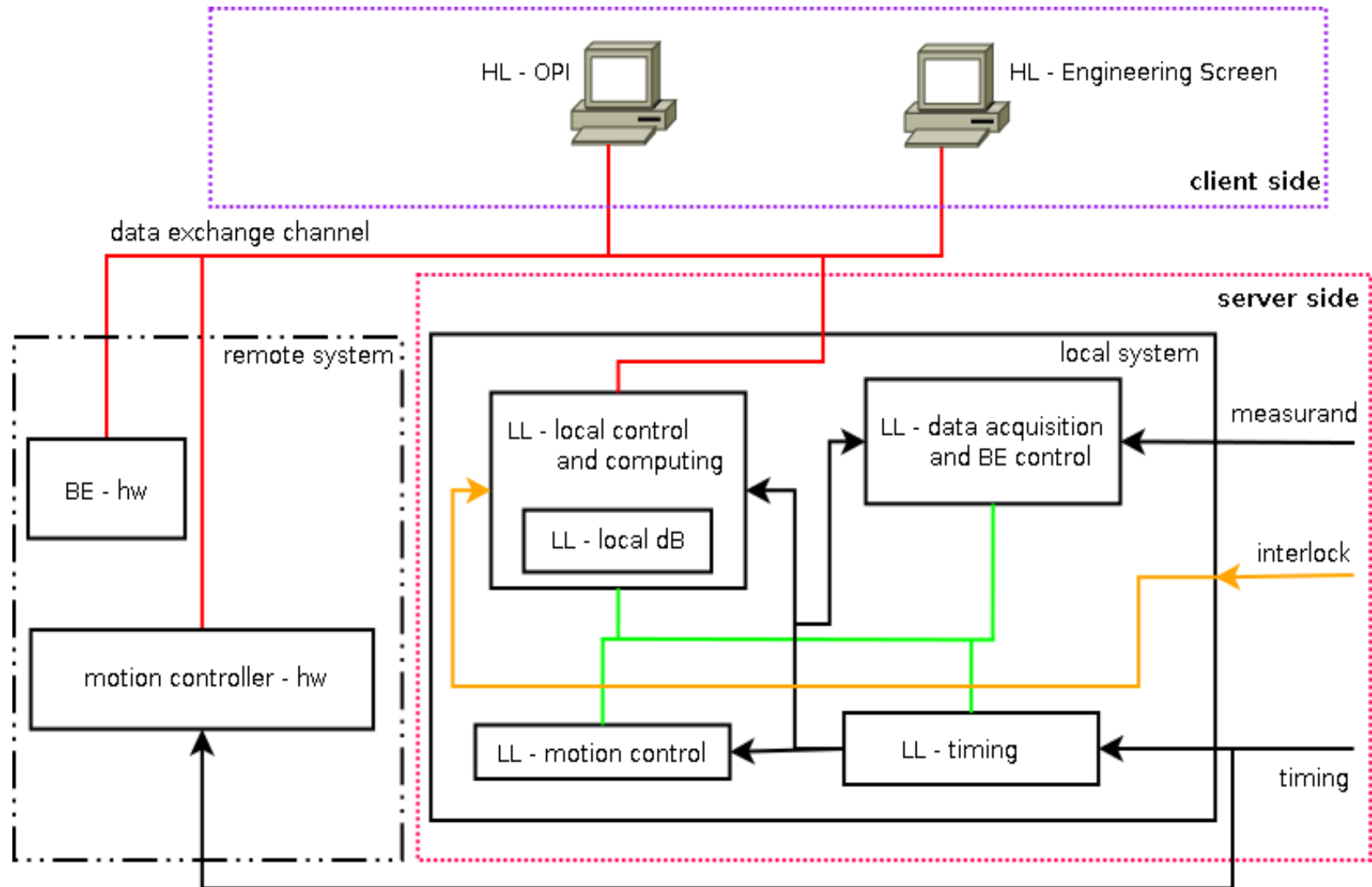

## Two layers SW architecture

- ✓ The High Level Layer (client side) is in charge of human interaction activities;
- ✓ The Low Level Layer (server side) is in charge of all kind of activities/functions strictly related to the WS operation:
  - Motion control: On The Fly and Step By Step trajectory management;
  - Data acquisition synchronized by/with the timing system;
  - Elaboration of the acquired raw data (raw means buffered by the underlying layer) accordingly to specified algorithms in order to calculate the beam profile;
  - State management (normal operation, alarms, ...);
  - BE control;
  - Auto-diagnosis function that checks the sanity of the ancillary equipment, both hardware (BE/AFE/OFE) and software (acquisition/timing/motion control underlying IOC);
- ✓ Constraints:
  - EPICS and CSS based;
  - Motion control (mctc demo) and “ACQ + Timing” (SIS8300 + EVR) sub IOCs are in charge of ESS;

## IOCs hierarchy

- ✓ At the bottom level are located the:
  - motion control (MCTC) IOC;
  - Acquisition plus Timing IOC (EVR-MTCA + SIS8300);
  - They act as **servers** for the upper level;
- ✓ At the top level is located the WS-IOC:
  - It is triggered by the SIS8300 acquisition buffers;
  - It fetches the data buffered by SIS8300;
  - It acts on MCTC in order to scan the beam;
  - It reads back the positions from the MCTC IOC;
- ✓ The Operator Interface/Engineer Panel interacts with the WS-IOC by the Channel Access Protocol

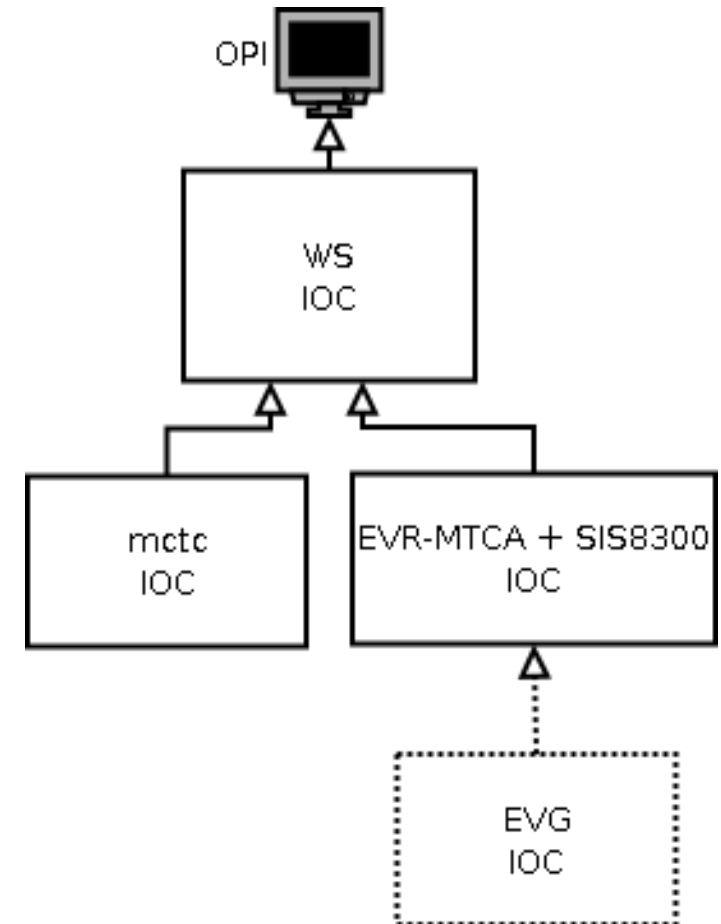

## AFE/OFE and WS-IOC

- ✓ Depending on the detecting mechanism (wire/optical), two kind of Front End have to be managed:
  - AFE: electrically connected to the scanning wires;
  - OFE: optically connected to the optical fibers of the scintillators;
- ✓ The amplifying hardware and data elaboration are different;
- ✓ At moment only the AFE case (“iocsh wsAFE.cmd”) has been fully validated;
- ✓ The OFE has been developed and is almost ready to be laboratory tested;

## Server Side (WS-IOC – AFE) simplified block diagram

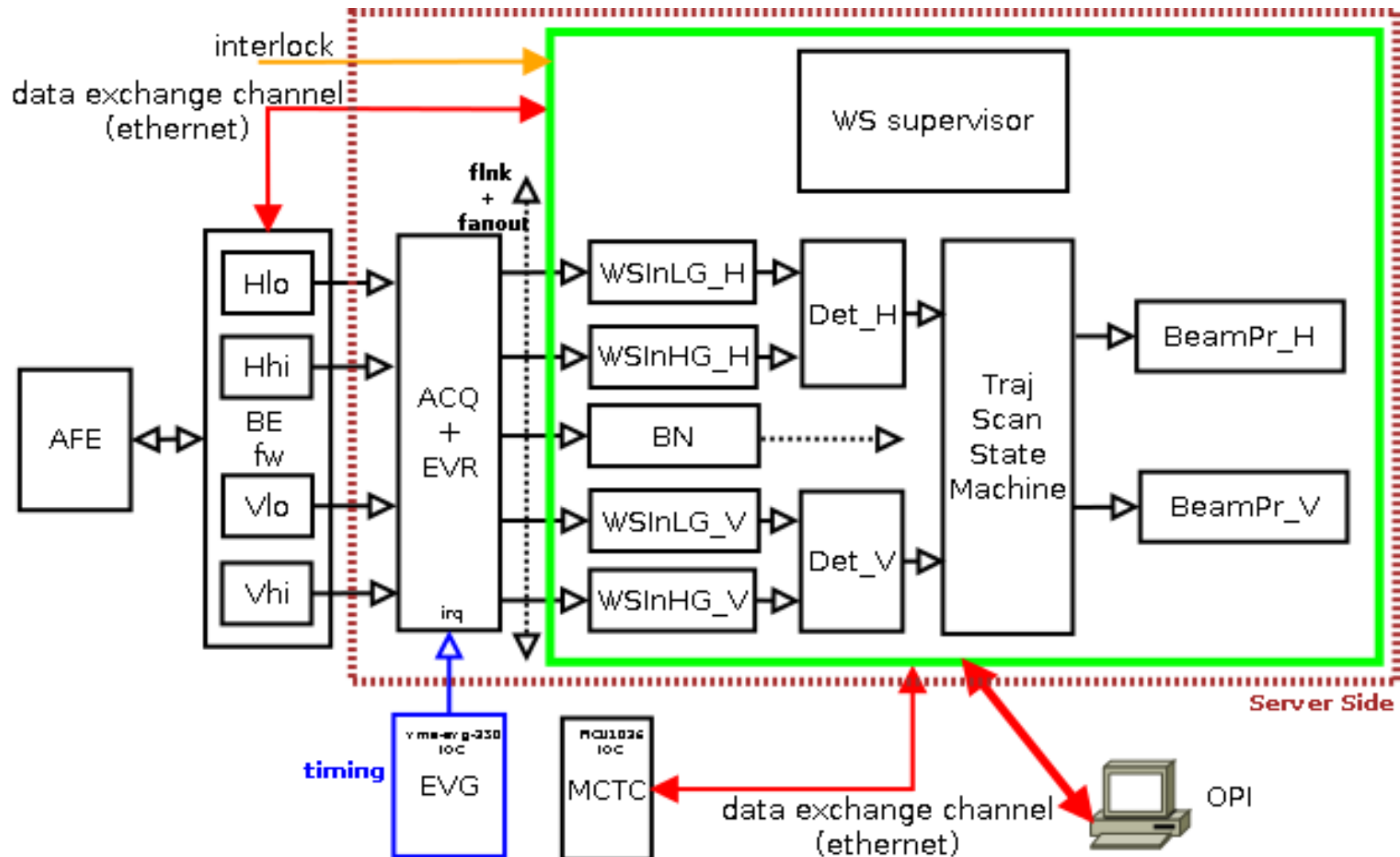





## Signal Processing Chain (triggered data processing pipeline)

- ✓ The sequence of operations required to obtain the beam shape have been split in a “pipeline” manner;
- ✓ Each stage of the pipeline performs a simple action;
- ✓ Any stage is triggered by the previous one and triggers the next stage;
- ✓ A state machine has been introduced in order to manage the “out of pipeline” (e.g. asynchronous) operations (trajectory scan);
- ✓ This model fits the EPICS “scan passive” concept;
- ✓ A set of forward links triggers the data flow;
- ✓ Periodic actions like IOC supervision are performed by periodic tasks (periodically scanned records);
- ✓ The primary trigger source is the event generated by the EVR in “EVR-MTCA” IOC;
- ✓ The event generates an IRQ that triggers the ADC acquisition (ACQ) in “SIS8300” IOC;
- ✓ Once ACQ buffers are available a CA forward link triggers the WS-IOC pipeline;

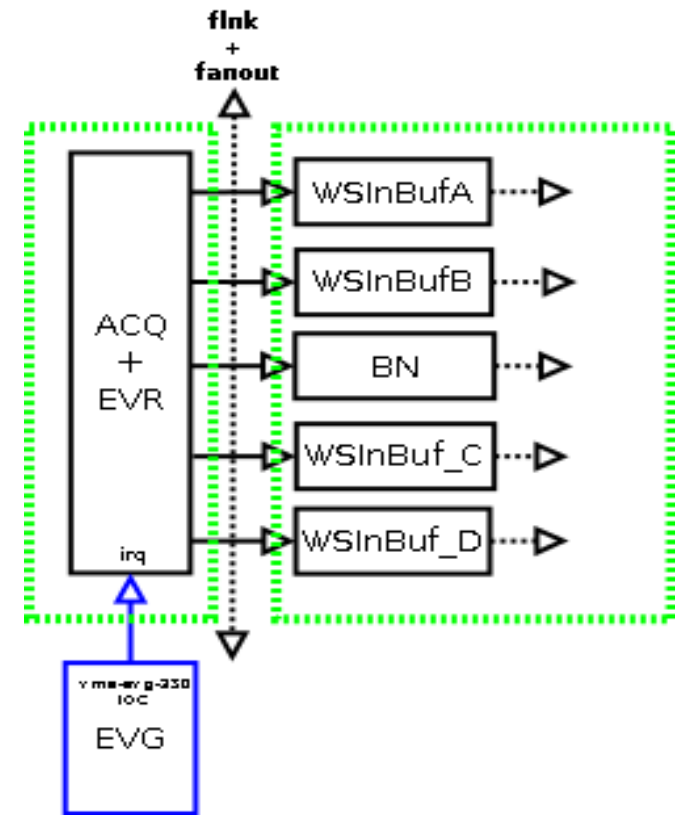

## Pipeline Stages (AFE)

✓ 1<sup>st</sup>: triggered by the “xxx:PropagateHWtriggerHV.PROC” CA FLNK, it processes a fanout record that triggers the following data fetching:

- SIS8300 buffers (Ai\* → WSInBuf\*);
- EVR-MTCA event counter (Event-X-Cnt-I → TrigSeqNum);

When WSInLG\_H and WSInLG\_V records processing ends two FLNK are triggered:

- DetectSaturationAndSelectArray\_H: H data path processing;
- DetectSaturationAndSelectArray\_V: V data path processing;

✓ 2<sup>nd</sup>: it is the most critical because it must:

- detect saturation effects in the input arrays. If both High Gain and Low Gain arrays are saturated a warning flag is set;
- scale the input signals according to the AFE analog parameters (offset and gain);
- calculate the LG channel array if the HG one is saturated;
- select which array must be propagated (HG, LG or LG “gray zone”);

When this stage ends two FLNK are triggered to process:

- DetectProfile\_H;
- DetectProfile\_V;

## Pipeline Stages (AFE)

- ✓ 3<sup>rd</sup>: this stage calculates the significant parameters of the previously processed arrays, basically the areas selected by user set markers. A number of algorithms is available (RMS, mean, ABS, background subtraction) to assess the (3) selected portions of the input signal.
- ✓ 4<sup>th</sup>: this stage merges the measured signal amplitudes and the scanned positions. Depending on the type of scan, the Trajectory Scan State Machine controls the record that collects the data necessary to build the beam profile:
  - OtF: position driven;
  - SbS: trigger driven;In both cases the H and V arrays containing the beam shape are filled sample by sample.
- ✓ Once the trajectory has been fully scanned, a user selectable fitting algorithm is applied;

## Trajectory scan

- ✓ Starting and ending positions, scan speed, step size and number of shots can be user or automatically configured;
- ✓ At the end of the “fast” wire insertion in the vacuum chamber (A segment, RAW profile estimation stage), automatic trajectory scan parameters are calculated (B interval);
- ✓ B, D, F: temporary stages that allow the MC to change its (speed, position) configuration;
- ✓ C, G: temporary stages to/from the “useful” beam span E;
- ✓ The “fine” scan is performed in the E;
- ✓ The “fine” shape is calculated in the H segment;
- ✓ Calculations are always performed only when the wire is put in “safe” positions;

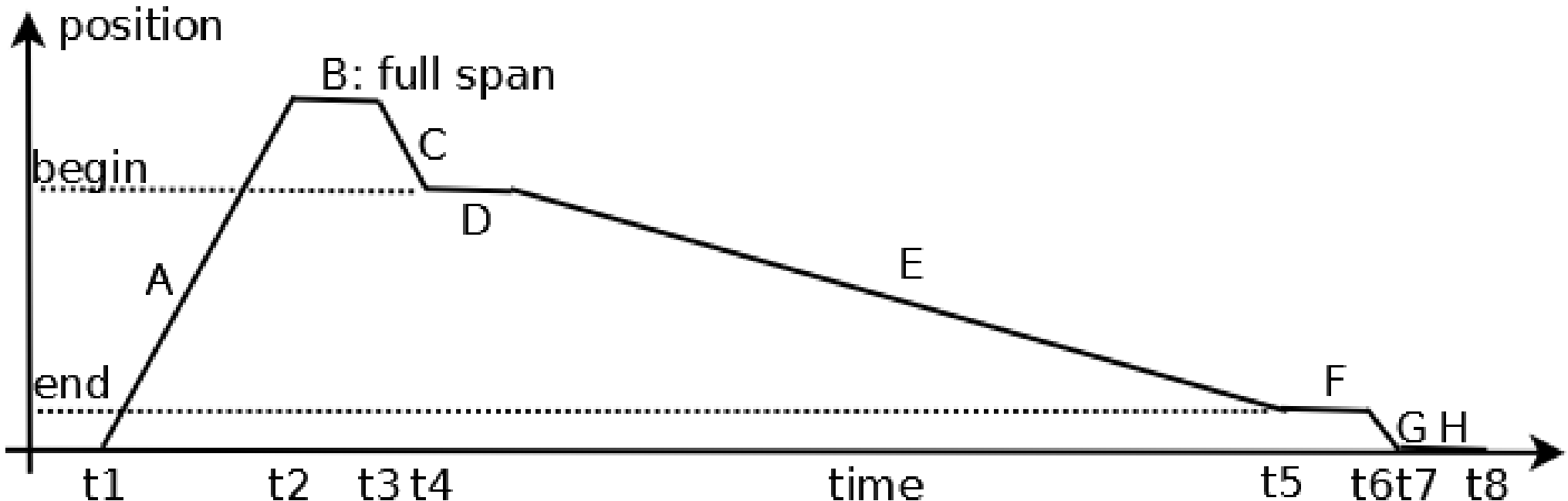

## Pipeline Stages (OFE)

- ✓ Basically the same as AFE (“simpler” because array “switching” is not required);
- ✓ 4 input channels couples are used (8 input signals);

## Other notes about OFE

- ✓ The greater number of input signals doesn't affect the global SW architecture;
- ✓ The BE must know if it is connected to AFE or OFE;
- ✓ It is difficult to maintain inside the same IOC the AFE and OFE data path differences;

## ADC IN channels

ADC in channels | WS IN channels | markers | beam | motion | Back End | log

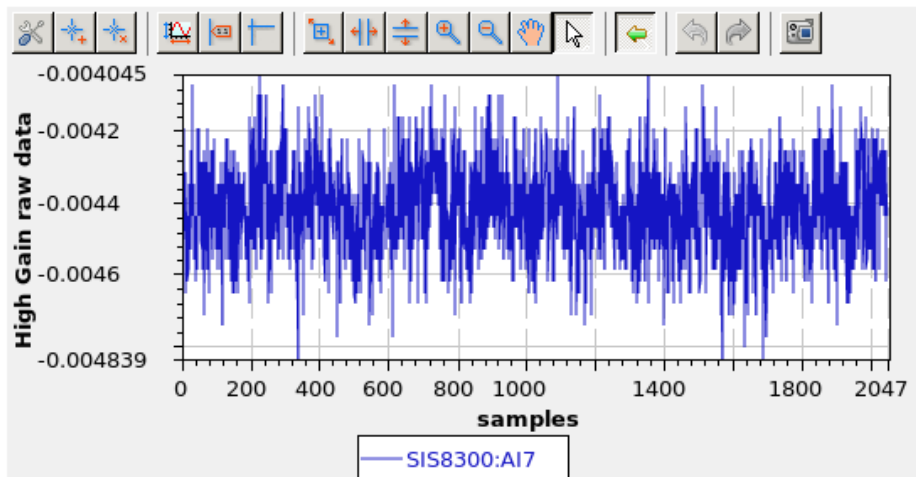
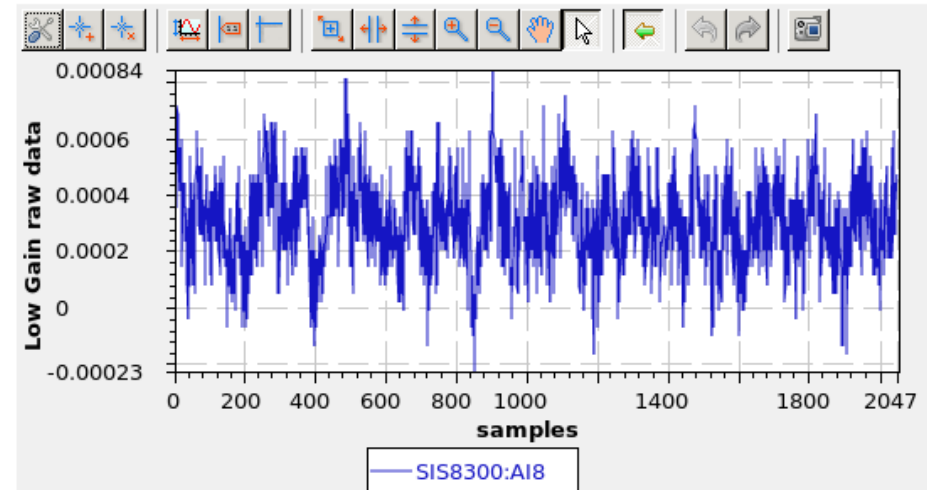
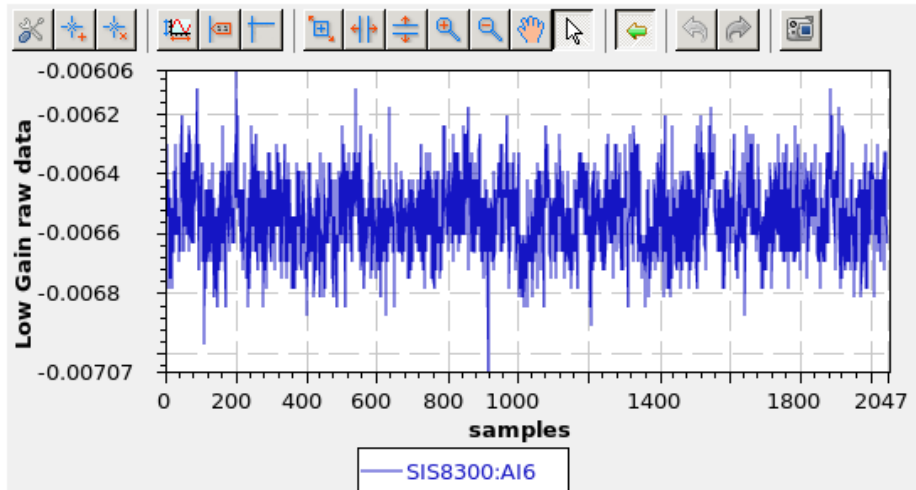

H

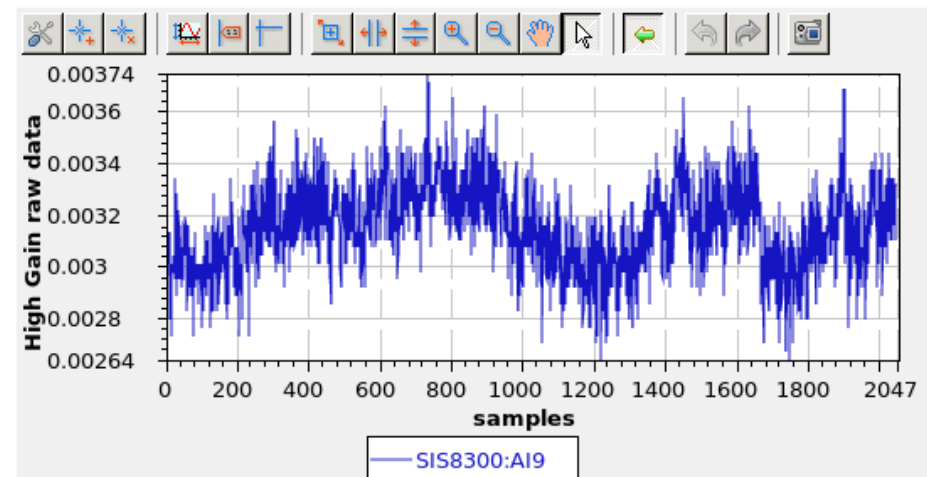

V

## WS IN channels

ADC in channels | **WS IN channels** | markers | beam | motion | Back End

TrigDelay  
-300  
TrigDelayRBV  
-300  
SamplingFreq.  
10000000  
10000000 Hz  
Trigger Status ●  
Beam Permit ●

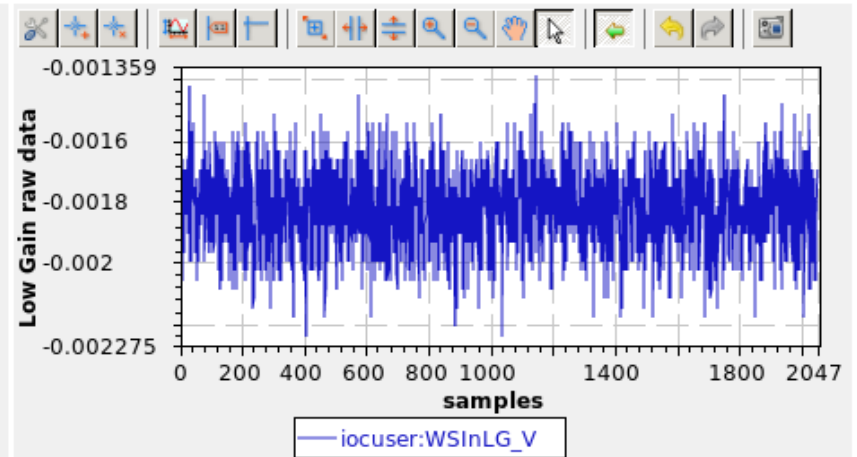
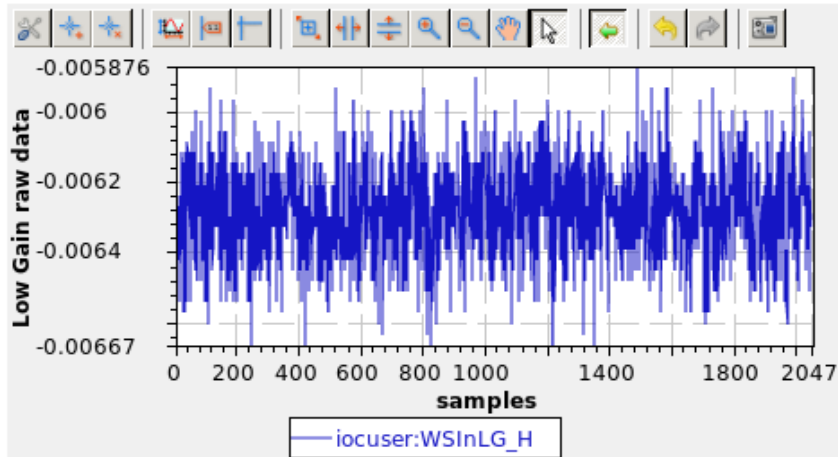

Bunch Number  
15417

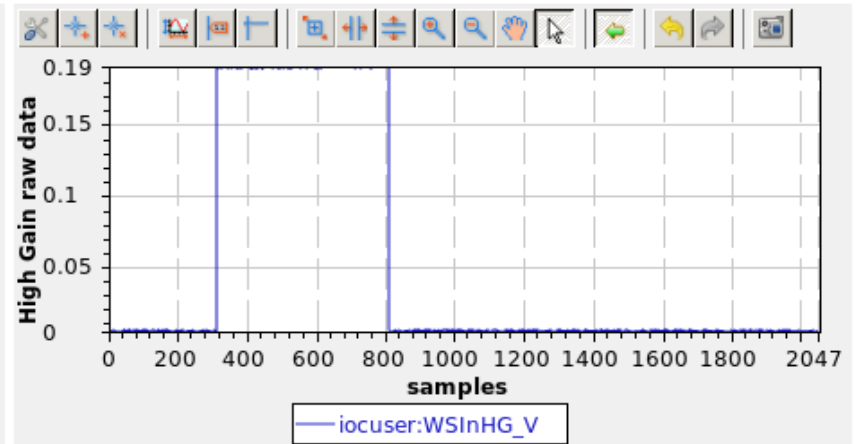
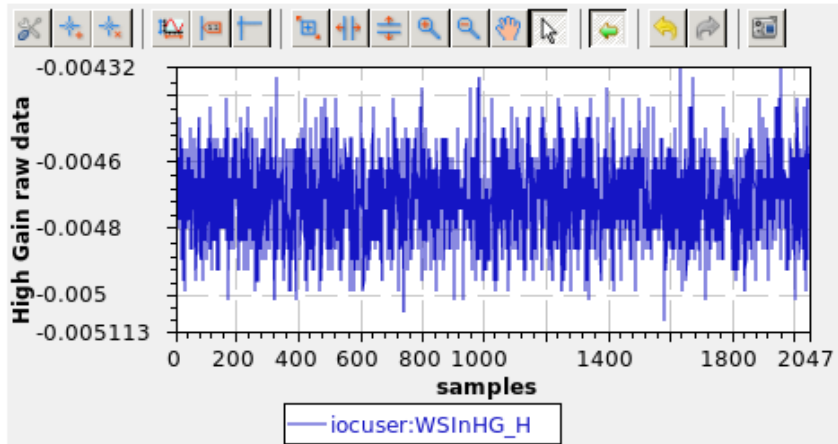

H

V

## Select&Scale input signal – AFE only

- ✓ Two signals are acquired per plane: WSInLG\_H, WSInHG\_H (H plane), and WSInLG\_V, WSInHG\_V (V plane)
- ✓ It is mandatory to compensate the gain change of the LG amplifier when HG amplifier saturates
- ✓ Saturation is detected when the portion of the signal inside the ROI exceeds the following thresholds:
  - `field(INPC, "$(user):HiSaturationThreshold_V NPP")`
  - `field(INPD, "$(user):LoSaturationThreshold_V NPP")`
  - `field(INPE, "$(user):SaturationLenghtPercentage_V NPP")`
- ✓ The following compensation is adopted when:
  - $HG_{signal} = (HG - HG\_OFFS) * HG\_GAIN$  – HG is not saturated at all;
  - $LG_{signal} = (LG - L\_OFFS) * LG\_GAIN$  – HG is not saturated inside ROI;
  - $LG_{signal} = ((LG - L\_OFFS) * LG\_GAIN\_HI) + LG\_OFFS\_HI$  – HG is saturated inside the ROI;



## Markers

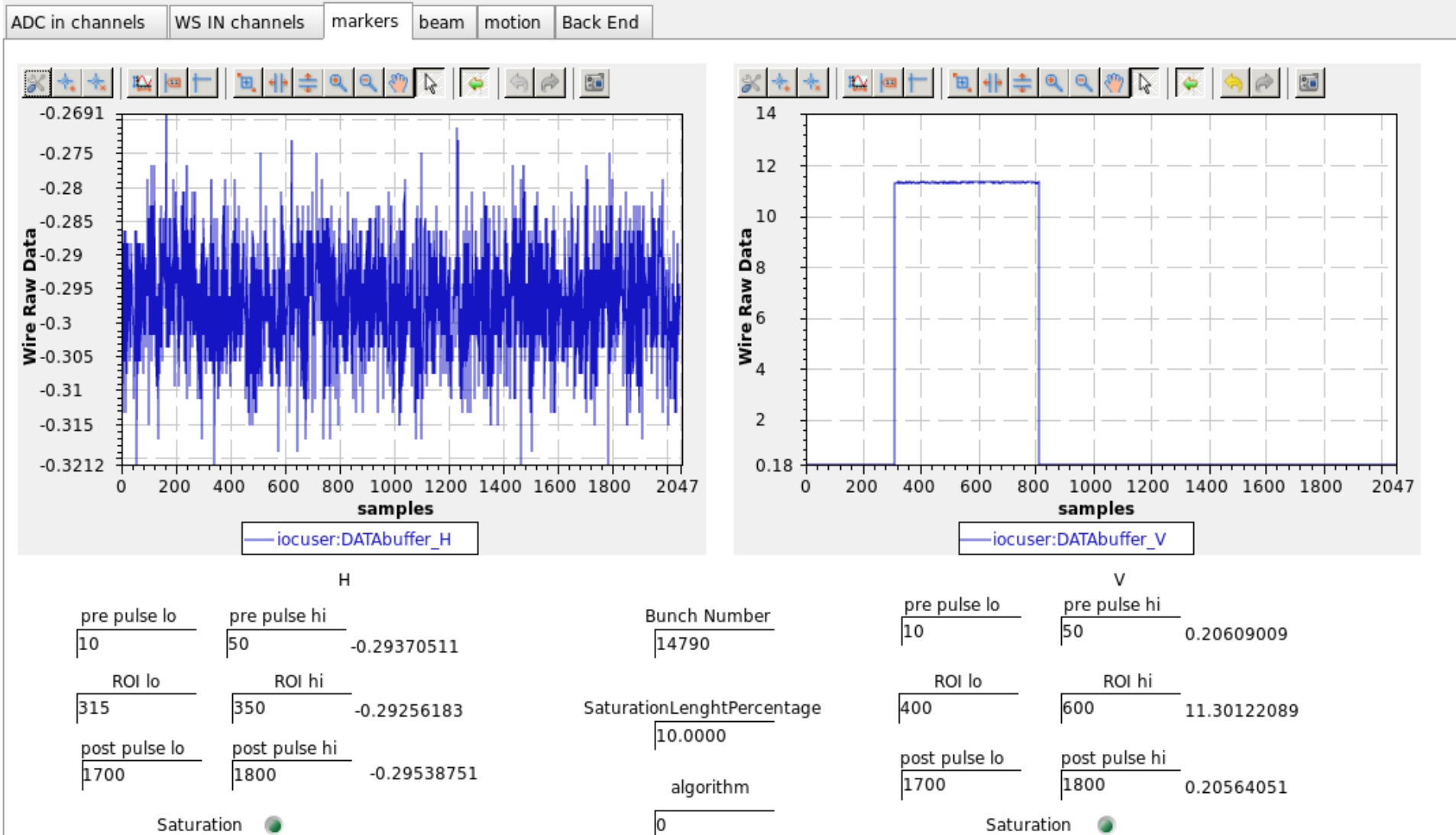

# A brief review (PDR2)

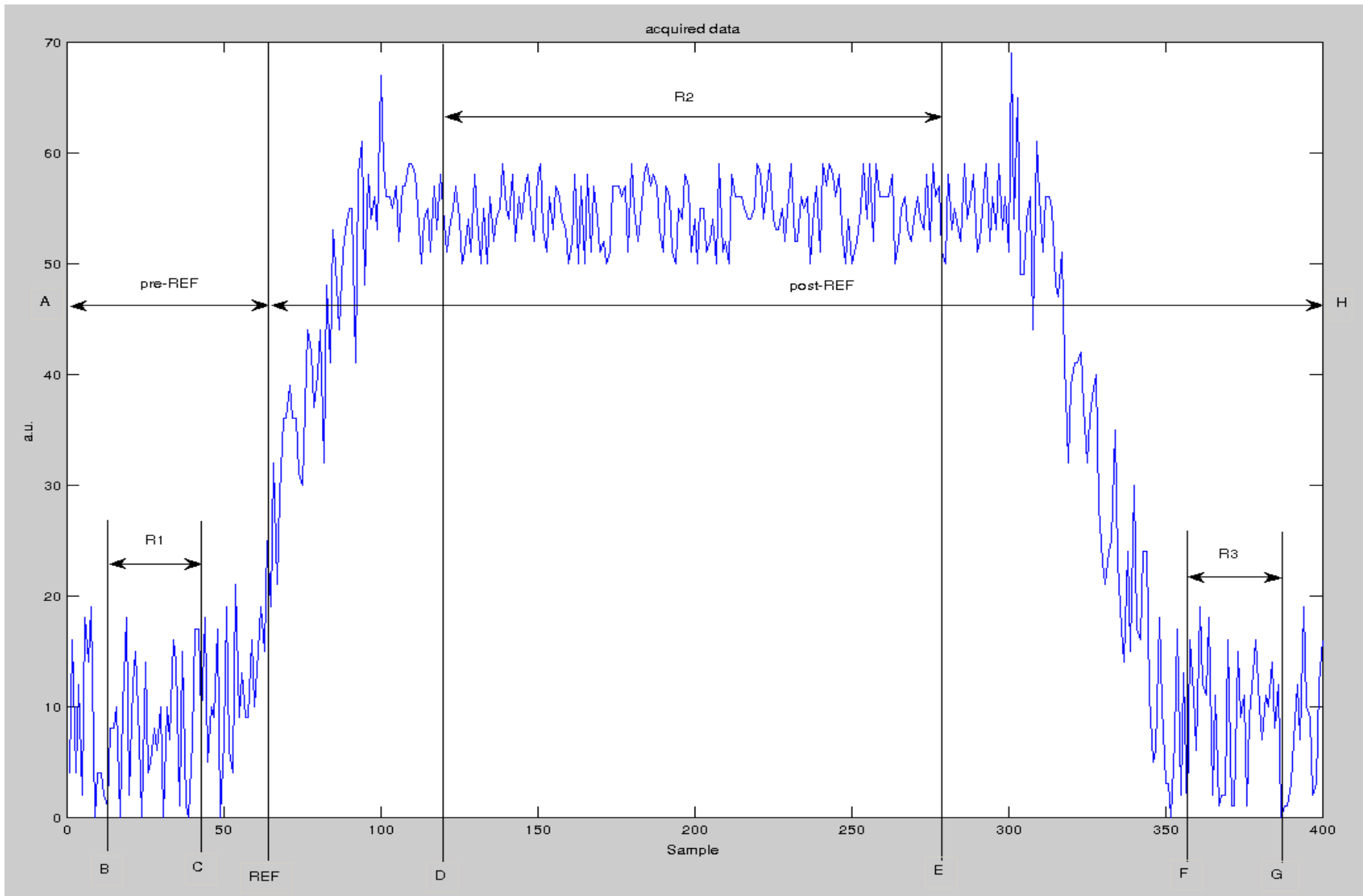

## Beam

ADC in channels
WS IN channels
markers
beam
motion
Back End

**BeamProfileH**

**BeamProfileV**

Bunch Number  
10067

45.0000	begin
110.0000	end
15.0000	step size
15	shots

Hor

Scan Plane

Manual

StepByStep

0

**START SCAN**

- ready
- homing
- moving
- scanning
- error
- abort
- done

AcquiredPoints

0

actual position

-0.030 mm	0
-0.030 mm	0

140.0000	begin
15.0000	end
12.0000	speed

Hor

Scan Plane

Manual

OnTheFly

**START SCAN**

**ABORT**

**Reset**

## Simulated Beam – Lab (VIT)

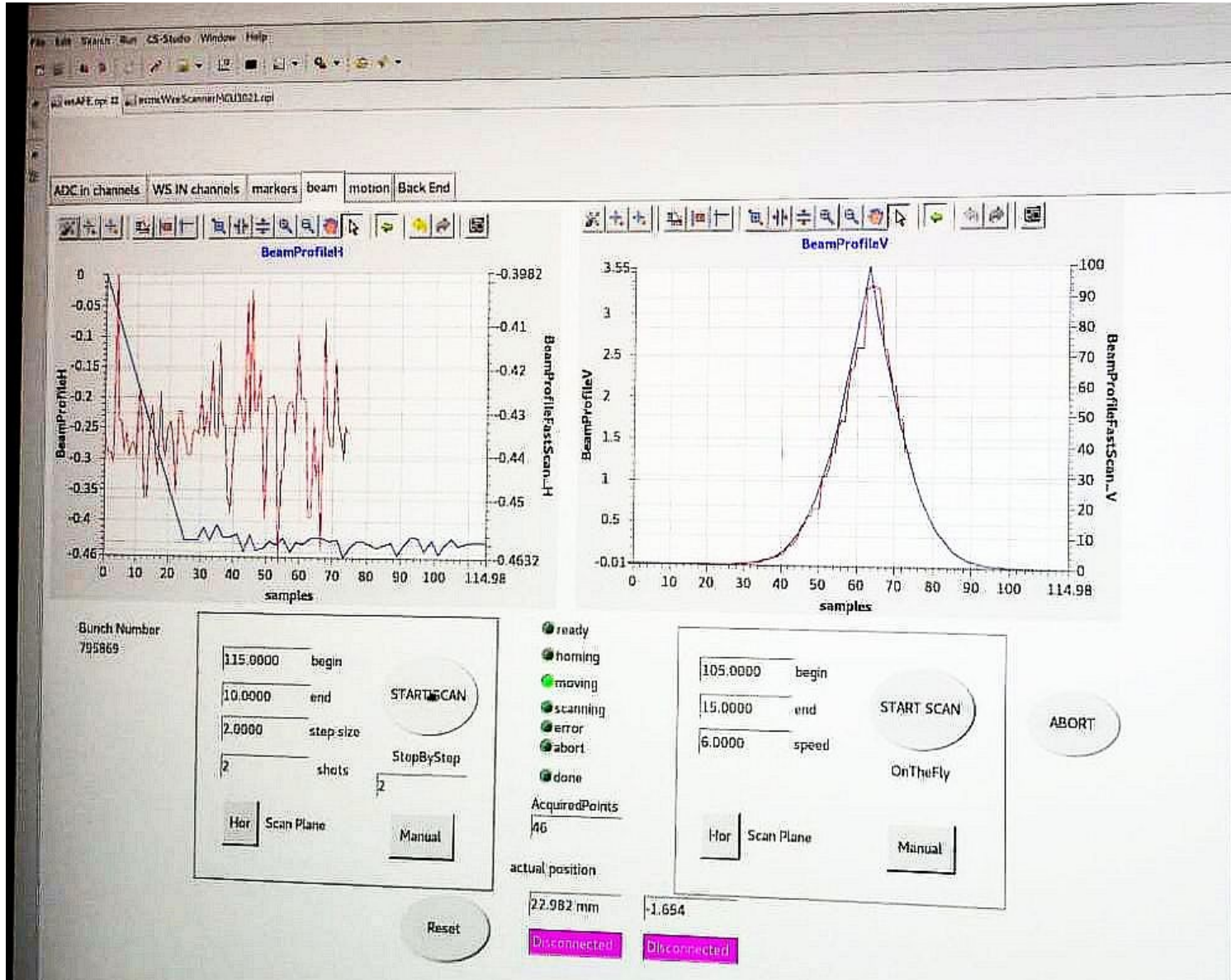

## Motion

ADC in channels | WS IN channels | markers | beam | motion | Back End

actual position

-0.030 mm

moving  
 scanning  
 error

140.0000 begin

15.0000 end

12.0000 speed

START SCAN

OnTheFly

45.0000 begin

110.0000 end

15.0000 step size

15 step size

START SCAN

StepByStep

ABORT

Bunch Number  
8739

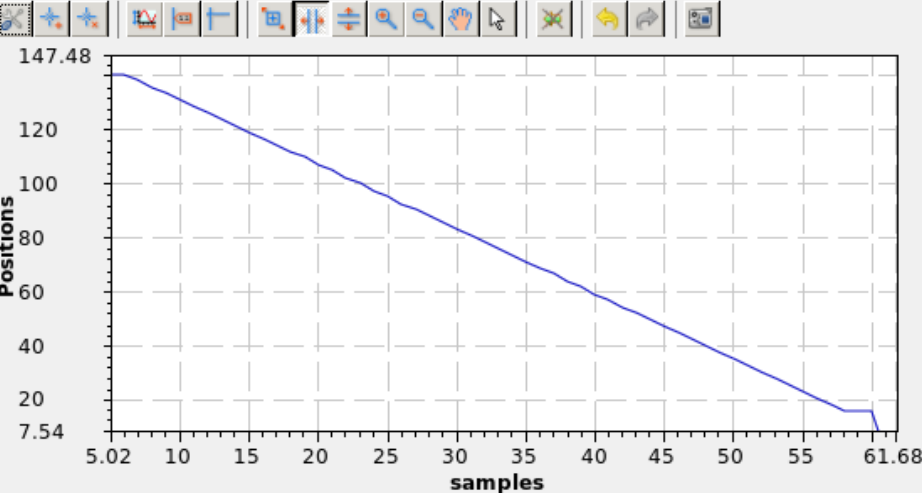

Positions: 147.48, 120, 100, 80, 60, 40, 20, 7.54

samples: 5.02, 10, 15, 20, 25, 30, 35, 40, 45, 50, 55, 61.68

H

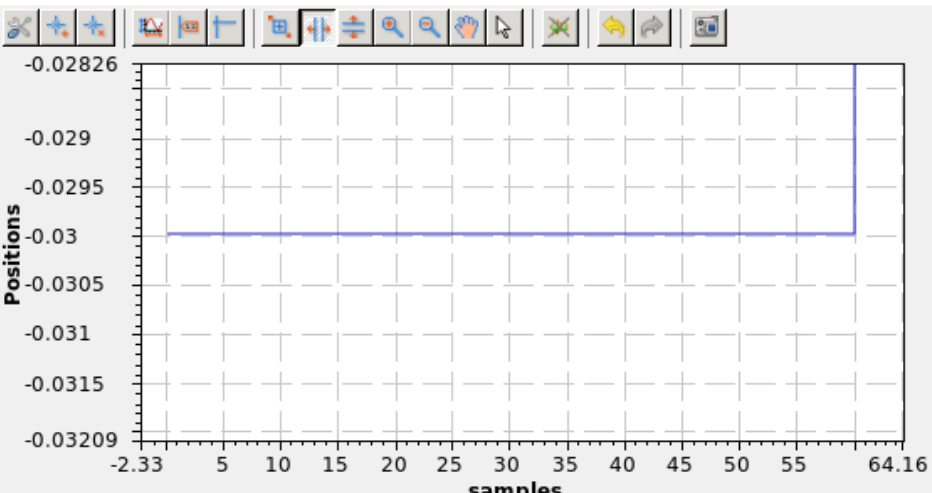

Positions: -0.02826, -0.029, -0.0295, -0.03, -0.0305, -0.031, -0.0315, -0.03209

samples: -2.33, 5, 10, 15, 20, 25, 30, 35, 40, 45, 50, 55, 64.16

V

## Motion

140.8900 begin

12.6000 end

2.0000 step size

5 shots

StepByStep

Ver Scan Plane

Manual

START SCAN

Reset

- ready
- homing
- moving
- scanning
- error
- abort
- done

AcquiredPoints

66

actual position

-0.030 mm

-0.030 mm

140.0000 begin

15.0000 end

12.0000 speed

OnTheFly

Hor Scan Plane

Auto

START SCAN

ABORT

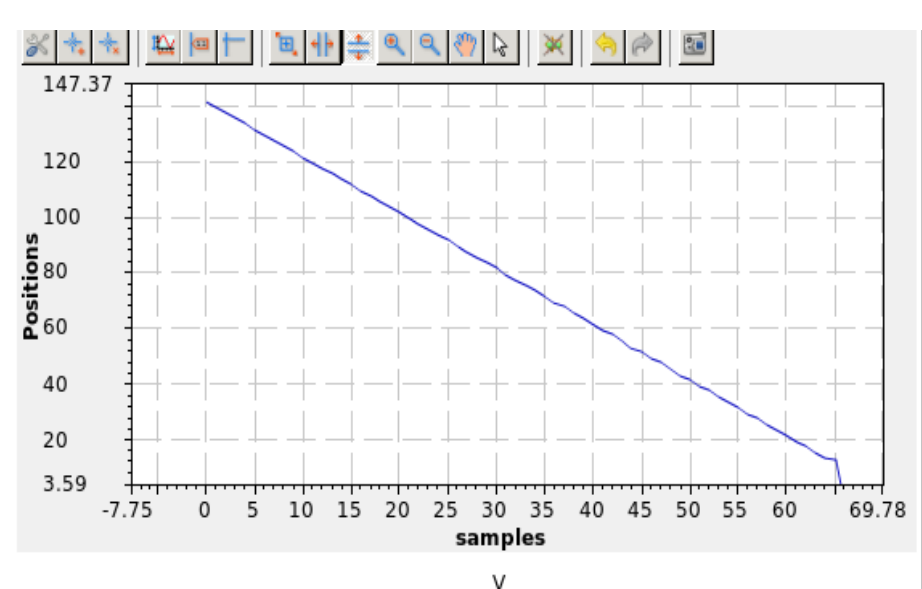
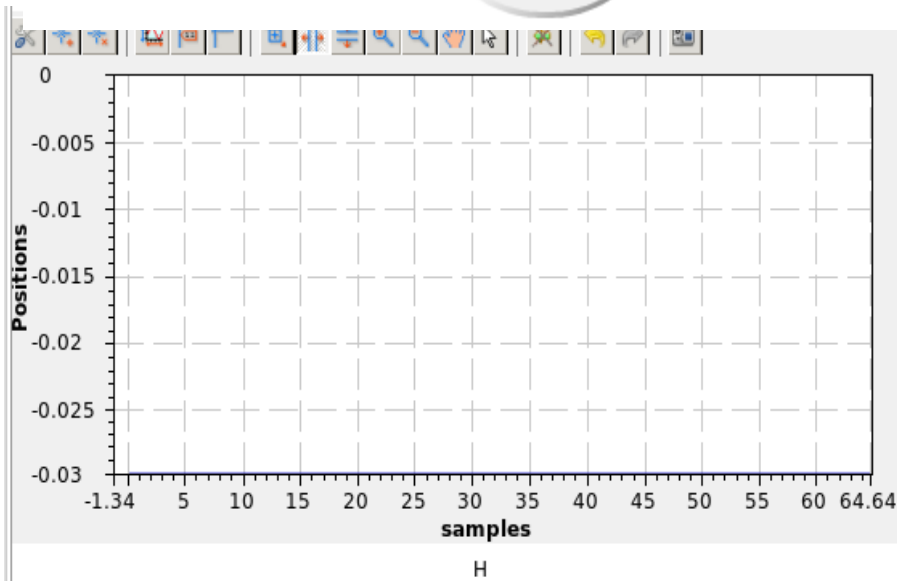



# OPI/EngPanel - 8



## BE

ADC in channels   WS IN channels   markers   beam   motion   Back End

BE bits readback  
255

BE status readback  
0:+0:255:0x122:1:R:12912:A02

BE voltage  
+0

BE temperature  
KO

BE set voltage  
|

BE set bits  
|

BE set pulses number for wire test  
|50

BE set input short  
|0

BE set gain  
|

BE reset

## BE – PIC db

```
record(stringin, "$(user):ReadStatus") {
  field(DTYP, "stream")
  field(INP, "@ws_protocol.proto ReadStatus asynstream")
  field(SCAN, "2 second")
}
record(stringin, "$(user):ReadBits")
record(stringin, "$(user):ReadGain")
record(stringin, "$(user):ReadVoltage")
record(stringin, "$(user):ReadTemp")
...

record(stringout, "$(user):SetVoltage") {
  field(DTYP, "stream")
  field(OUT, "@ws_protocol.proto SetVoltage asynstream")
}
record(stringout, "$(user):Default") //reset//
record(stringout, "$(user):SetBits")
record(stringout, "$(user):SetPulseNumberForWireTest")
record(stringout, "$(user):SetPulseTimeForWireTest")
record(stringout, "$(user):SetGain")
...
```



## BE – PIC protocol

```
ReadStatus {  
    out "RS?";  
    in "%s";  
    ExtraInput = Ignore;  
}  
ReadVoltage - out "RV?";  
ReadBits - out "RB?";  
ReadGain - out "RG?";  
ReadTemp - out "RT?";  
...  
  
SetBits {  
    out "SB:%s";  
    in "%{OK|KO}";  
    ExtraInput = Ignore;  
}  
SetPulseNumberForWireTest - out "SP:%s";  
SetPulseTimeForWireTest - out "SC:%s";  
SetGain - out "SG:%s";  
SetVoltage - out "SV:%s";  
Default - out "DF";  
...
```

## Log – (CERN, Linac4) – discontinued feature

ADC in channels | WS IN channels | markers | beam | motion | Back End | log

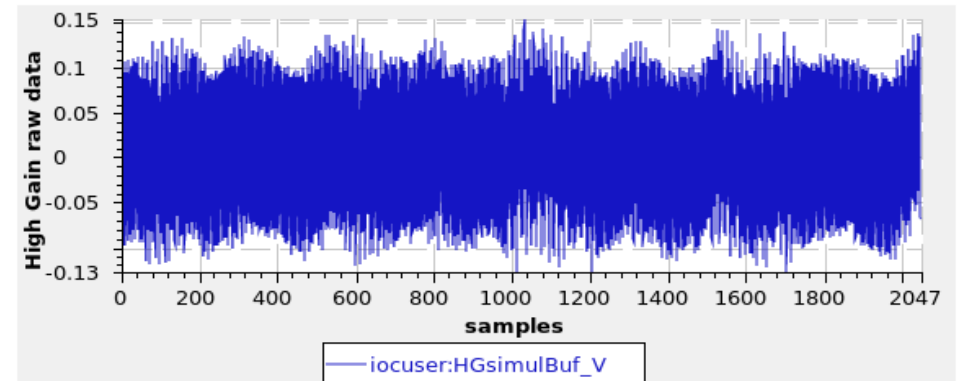
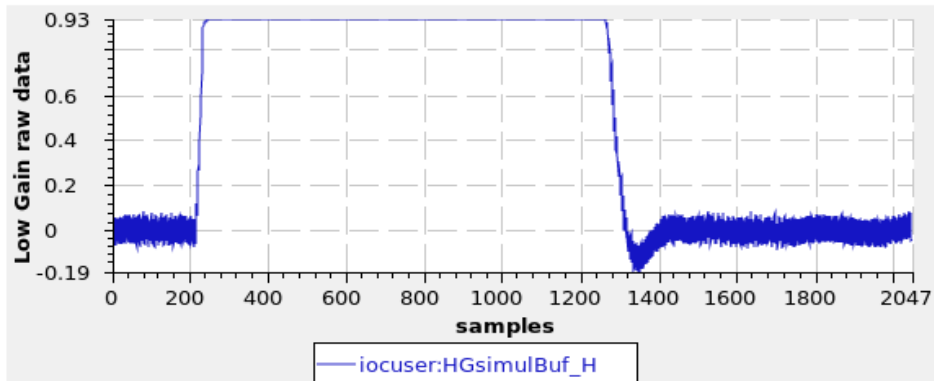
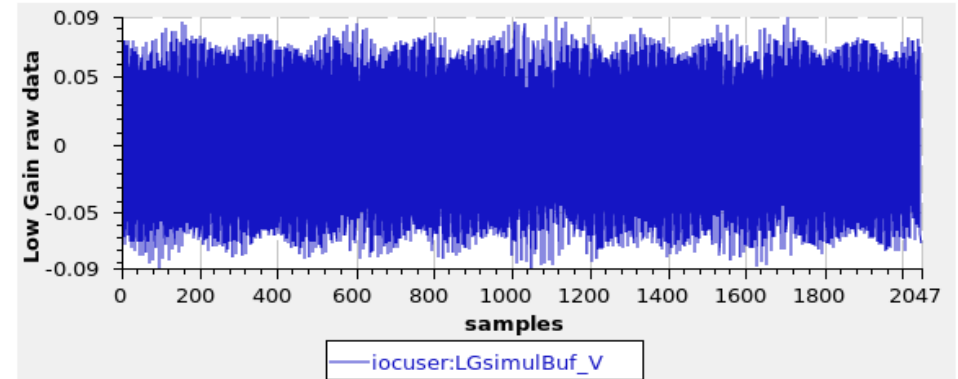
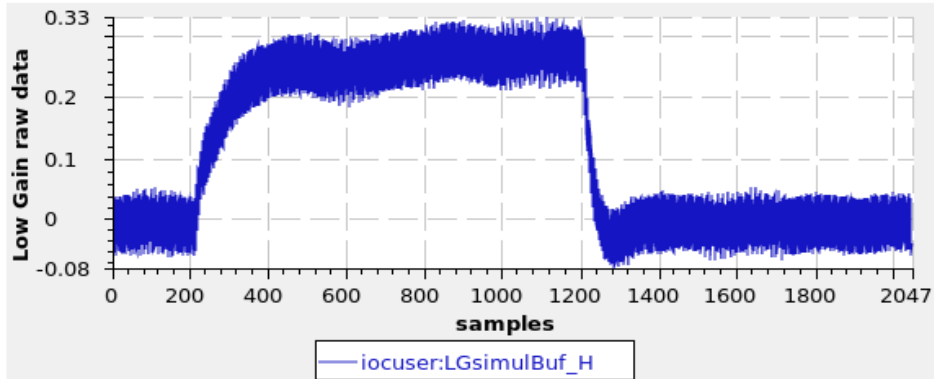

view log  
 real inputs  
 restore default

```
state ScanStepByStep //position oriented//
```

```
{  
  GetScanSetup  
  GetMCTCstate  
  HomeMCTC  
  |(MCTCerror)-> ManageError(ErrorCodeStepByStep_GetMCTCstate, ErrorCodeStepByStep_HomeMCTC,  
  CheckRetVals)  
  |(OK)-> CheckWire  
  |-> ScanStepByStep  
}
```

```
state ScanOnTheFly //speed oriented//
```

```
{  
  GetScanSetup  
  GetMCTCstate  
  HomeMCTC  
  |(MCTCerror)-> ManageError(ErrorCodeOnTheFly_GetMCTCstate, ErrorCodeOnTheFly_HomeMCTC,  
  CheckRetVals)  
  |(OK)-> CheckWire  
  |-> ScanOnTheFly  
}
```

```
state CalculateStartStopStepSpeed
```

```
{  
  GetFastScanBuffers  
  Calculate Start, Stop, Step, Speed for slow scansion  
  |(error)-> ManageError(ErrorCodeCalculateStartStopStepSpeed)  
  |(OK)-> SetGetCheckAcq0  
}
```

## CERN - Linac4

- ✓ Data Acquisition ability: PASS
- ✓ Pipeline mechanism: PASS
- ✓ Detecting and switching algorithms: PASS
- ✓ BE control: PASS
- ✓ Log mode: PASS (this feature was used only for E-ST debug)
- ✓ Beam Profile Building algorithm: NA (motion controller not available, only post processing was feasible)

## E-ST labo

- ✓ Trigger frequency increased to 20 Hz: PASS (! mctc warning)
- ✓ Trajectory scan both OtF and SbS: PASS
- ✓ Full beam scan simulation: PASS (! 1Hz repetition rate)
- ✓ WARNING: it **seems** that the maximum CA refresh frequency (camonitor) of the motion controller IOC is 5 Hz, see next slides

## VIT@Lund (August 2018 – wsAFE)

- ✓ Porting from EEE to E3 (many thanks to Lund Team (J.P., C., ...))
- ✓ Full functional test: PASS
- ✓ IOC code “delivered” to ESS ([bitbucket/europeanspallationsource/m-epics-wirescanner](https://bitbucket/europeanspallationsource/m-epics-wirescanner))

- ✓ iocuser:Positions 2018-03-02 20:54:19.163954 10 15 0 0 0 0 0 0 0 0 0
- ✓ iocuser:Positions 2018-03-02 20:54:19.213752 10 15 15 0 0 0 0 0 0 0 0
- ✓ iocuser:Positions 2018-03-02 20:54:19.263757 10 15 15 15 0 0 0 0 0 0 0
- ✓ iocuser:Positions 2018-03-02 20:54:19.313626 10 15 15 15 15 0 0 0 0 0 0
- ✓ iocuser:Positions 2018-03-02 20:54:19.363777 10 15 15 15 15 15 0 0 0 0 0
- ✓ iocuser:Positions 2018-03-02 20:54:19.413019 10 15 15 15 15 15 15 0 0 0 0
- ✓ iocuser:Positions 2018-03-02 20:54:19.463545 10 15 15 15 15 15 15 15 0 0 0
- ✓ iocuser:Positions 2018-03-02 20:54:19.513234 10 15 15 15 15 15 15 15 15 0 0
- ✓ iocuser:Positions 2018-03-02 20:54:19.563448 10 15 15 15 15 15 15 15 15 15 0
- ✓ iocuser:Positions 2018-03-02 20:54:19.613874 10 15 15 15 15 15 15 15 15 15 15.3

0.05 s period – 20 Hz, the EVG Trigger frequency: OK!

- ✓ caget: iocuser:Positions 2048 15 15 15 15 15 15 15 15 15 15.3 15.3 15.3 15.3 15.72 15.72 15.72 15.72 16.11 16.11 16.11 16.5 16.5 16.5 16.5 16.92 16.92 16.92 16.92 17.31

# MCTC limitation?

- ✓ IOC\_WS:Axis1.RBV 2018-03-02 20:48:01.812140 20.94
- ✓ IOC\_WS:Axis1.RBV 2018-03-02 20:48:02.012988 21.36
- ✓ IOC\_WS:Axis1.RBV 2018-03-02 20:48:02.213861 21.75
- ✓ IOC\_WS:Axis1.RBV 2018-03-02 20:48:02.414765 22.14
- ✓ IOC\_WS:Axis1.RBV 2018-03-02 20:48:02.615534 22.56
- ✓ IOC\_WS:Axis1.RBV 2018-03-02 20:48:02.816206 22.98
- ✓ IOC\_WS:Axis1.RBV 2018-03-02 20:48:03.016924 23.37
- ✓ IOC\_WS:Axis1.RBV 2018-03-02 20:48:03.217634 23.79
- ✓ IOC\_WS:Axis1.RBV 2018-03-02 20:48:03.418367 24.18
  
- ✓ 0.2 s period – 5 Hz

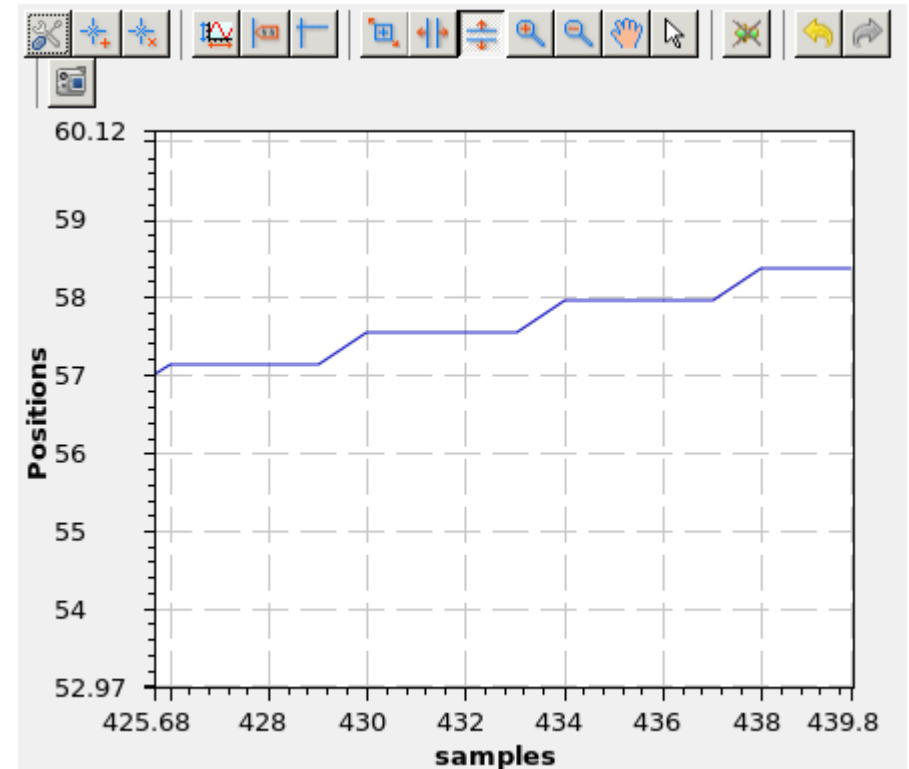

# Vertical Integration Test

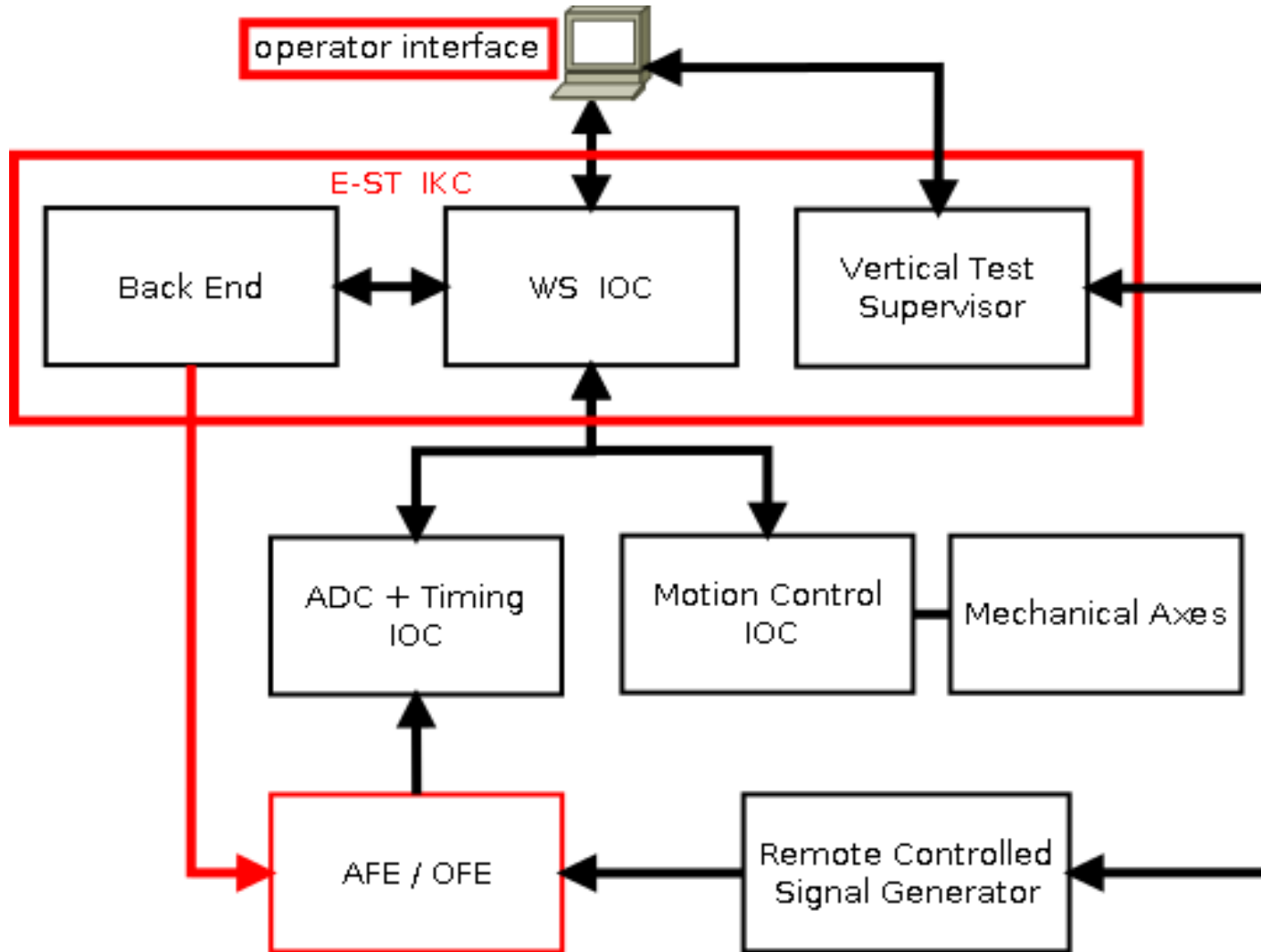

## Acceptance Test Support Application

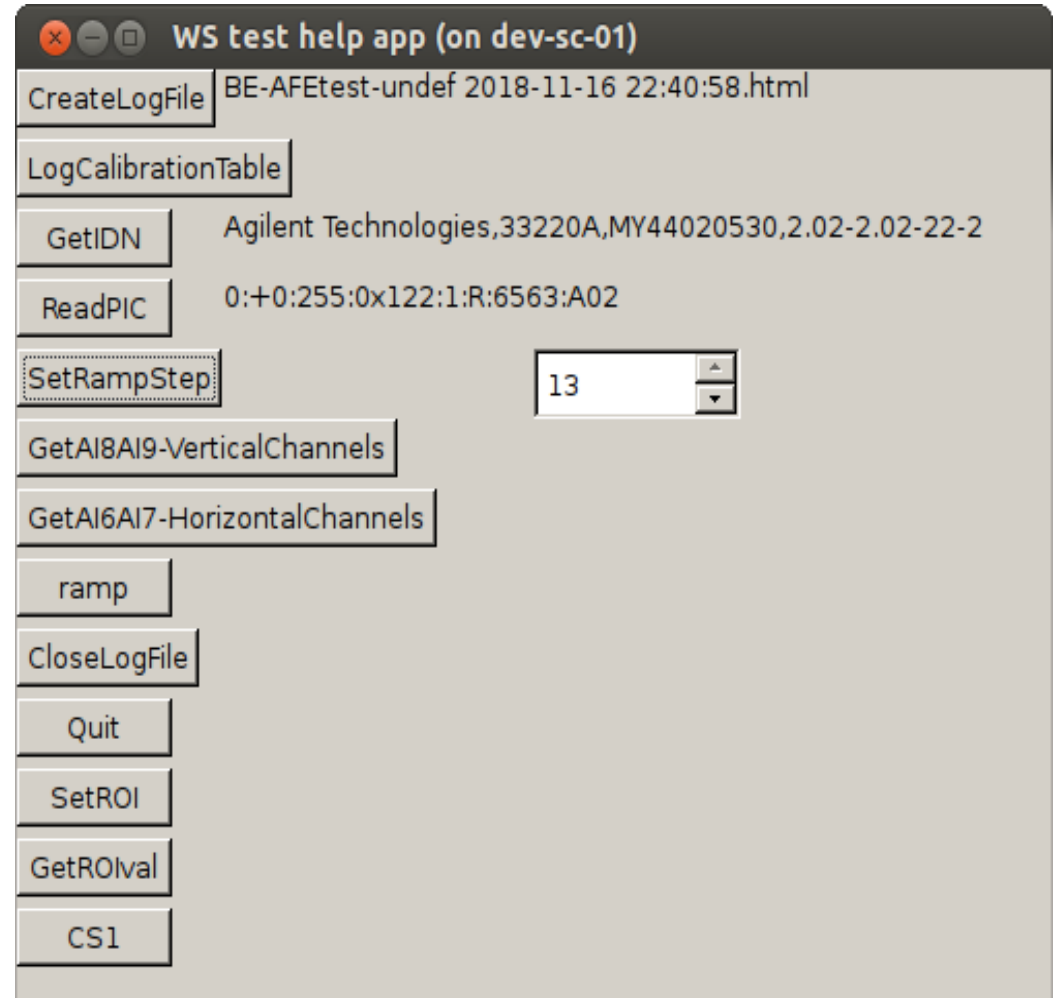



## BE-AFEtest-undef 2018-11-16 22:28:56

### Calibration Table:

#	current	units	Vscope	units	Vpuls	Max	units	Vpuls	Min	units	RefLevel	HiGain	units	RefLevel	LoGain	units
1	10	nA	1.245	V	1.255	V	1.1	V	0.0	V	0.0	V	0.0	V		V
2	30	nA	1.27	V	1.285	V	1.1	V	0.003697	V	0.0	V	0.0	V		V
3	50	nA	1.28	V	1.295	V	1.1	V	0.003954	V	0.0	V	0.0	V		V
4	100	nA	1.31	V	1.322	V	1.1	V	0.005818	V	0.0	V	0.0	V		V
5	300	nA	1.336	V	1.346	V	1.1	V	0.009588	V	0.0	V	0.0	V		V
6	500	nA	1.348	V	1.36	V	1.1	V	0.013277	V	0.0	V	0.0	V		V
7	1	uA	1.37	V	1.383	V	1.1	V	0.022346	V	0.0	V	0.0	V		V
8	3	uA	1.42	V	1.45	V	1.1	V	0.075673	V	0.0	V	0.0	V		V
9	5	uA	1.45	V	1.48	V	1.1	V	0.111941	V	0.000477	V	0.000477	V		V
10	10	uA	1.51	V	1.56	V	1.1	V	0.231239	V	0.001994	V	0.001994	V		V
11	30	uA	1.695	V	1.8	V	1.1	V	0.664866	V	0.007636	V	0.007636	V		V
12	50	uA	1.865	V	2.035	V	1.1	V	0.854769	V	0.04413	V	0.04413	V		V
13	100	uA	2.26	V	2.6	V	1.1	V	0.85774	V	0.183188	V	0.183188	V		V
14	300	uA	4.01	V	5.0	V	1.1	V	0.857473	V	0.563845	V	0.563845	V		V

\*\*\*\*\*

Agilent Technologies,33220A,MY44020530,2.02-2.02-22-2

\*\*\*\*\*

PIC-BE: 0:+0:255:0x122:1:R:3249:A02

BE id: undef

AFE id: undef

\*\*\*\*\*

SetRampStep - SetGenerator: 300 uA -- 5.0 V -- 1.1 V

SetRampStep - GetGenerator: 300 uA -- 5.0 V -- 1.1 V

# Test App - 3

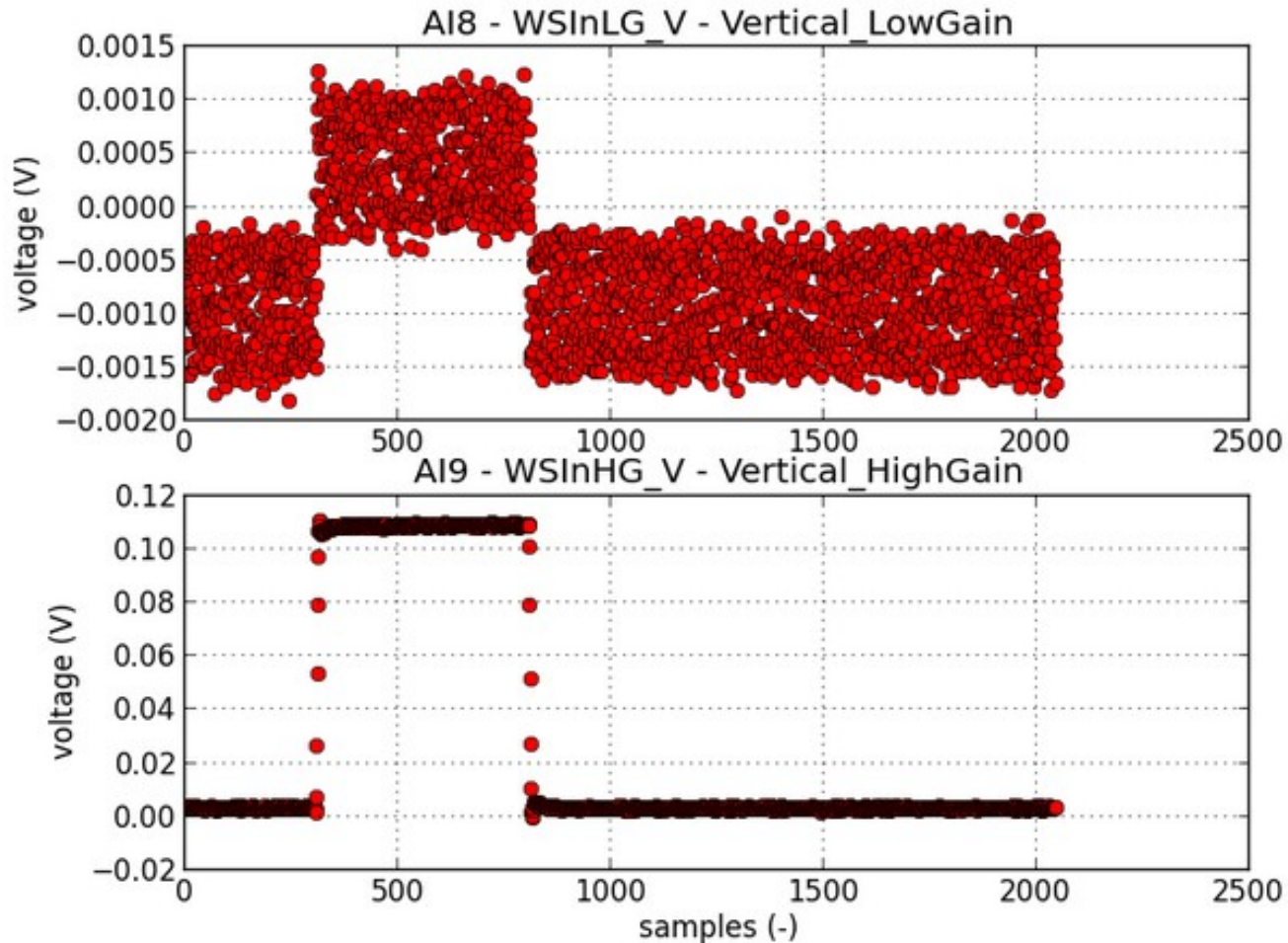

AI8 mean(ROI): 0.000424 V -- ROIlo: 500 -- ROIhi: 700  
AI8 st.dev.(ROI): 0.000403 V -- ROIlo: 500 -- ROIhi: 700  
AI8 mean(BKG): -0.000931 V -- BKGlo: 1400 -- BKGhi: 1800  
AI8 st.dev.(BKG): 0.000392 V -- BKGlo: 1400 -- BKGhi: 1800  
AI8 mean(ROI - BKG): 0.001355 V  
AI8 st.dev.(ROI - BKG): 0.000011 V

# Conclusions

- ✓ The “final” release of the WS IOC for AFE (wsAFE) behaved fine during the VIT;
- ✓ The wsOFE is ready for Lab Test;
- ✓ The refresh rate of the position is still limited to 5 Hz;



Elettra  
Sincrotrone  
Trieste

**Thank You!**

[www.elettra.eu](http://www.elettra.eu)