

icBLM system overview

Irena Dolenc Kittelmann

ESS

(BLM System Lead)

- ESS BLM
 - Reminder
 - L4 requirements

- icBLM
 - teams involved
 - Interfaces
 - Components overview
 - Project timeline
 - Procurement plan
 - FW/SW development plan

- CDR1
 - charge

Two BLM systems

■ icBLM

- Primary monitor in the high energy parts
- Detector: ionization chambers (ICs)

■ nBLM

- Primary monitor in the low energy parts
- Detector: micromegas detectors

Linac section	Num. of devices			
	icBLM comment	count	nBLM comment	count
MEBT		/		2F+2S=4
DTL	1/tank	5×1=5	8/tank,2/end	5×(4F+4S)+1F+1S=42
Σ		5		23F+23S=46
Spoke	1/cryo,3/2q	13×4=52	1/2q, 1/cryo	13×(F+S)=26
MB	1/cryo,3/2q	21×4=84		1F+1S=2
HB	1/cryo,3/2q	9×4=36		1F+1S=2
MEBT	3/2q	16×3=48		/
A2T				
ramp to target	1/bend,3/2q	6×3+2×1=20		1F+1S=2
dump	3/2q, 3/4rast. 1/mag.	3×3+2×3=15 6		2F+2S=4 /
Σ		261		18F+18S=36
ΣΣ		266		41F+41S=82
ΣΣΣ				348

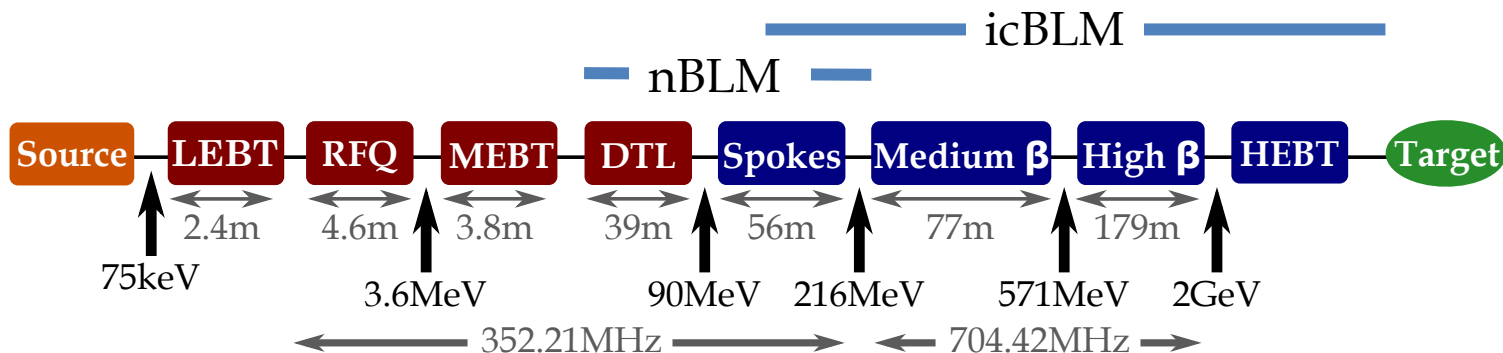

BLM L4 requirements

#	Type	Name	Description	
1	Beam loss	XXX beam loss measurement	The beam loss shall be measured in the XXX section.	→ Coverage
2	Beam loss	XXX beam loss measurement sensitivity	A beam current loss of 10 mW/m shall be detected.	→ Sensitivity, lower limit
3	General	XXX PBI damaging beam detection mitigation	Beam conditions that are potentially damaging to machine components shall be detected by the instrumentation and reported fast enough so that the conditions can be mitigated before damage occurs.	→ Upper limit, response time, MP thresholds
4	General	XXX PBI peak current range	Proton beam instrumentation in the XXX section shall function over a peak beam current range of 3 mA to 65 mA.	} System functioning for all beam modes
5	General	XXX PBI pulse length range.	Proton beam instrumentation in the XXX section shall function over a proton beam pulse length range of 5 μ s to 2.980 ms.	
6	General	XXX PBI pulse-by-pulse measurement update rate	Unless specifically stated, all instrumentation shall be able to perform the measurements and report the relevant PV data at a repetition rate of 14 Hz.	

Table 1: L4 PBI requirements [2] relevant for the BLM system. The 'XXX' refers to specific linac section and runs over all section from including MEBT on.

icBLM: teams involved

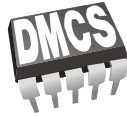

LUT DMCS (ICS IK)

- FPGA FW design and implementation
- SW design and implementation



ESS BD

- System architecture, for example
 - Detectors & electronics
 - Detector and electronics layout
 - Mechanical support
 - Development of specifications and requirements
 - Spec. relevant for detector design
 - Def. of FW and SW functionality
 - Def. of data processing (FPGA algos)
 - Definition of monitoring variables and algos
 - Beam loss simulations: MC simulation of lost protons
- Installation
- System commissioning
- Coordination & project management

ESS ICS

- FW and SW support and integration

icBLM: teams involved

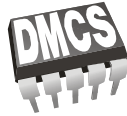

LUT DMCS (ICS IK)

- W. Cichalewski (local coordinator)
- G. Jablonski (FW, SW)
- R. Kielbik (FW)
- W. Jalmuzna (FW)



ESS BD

- T. Shea (section leader, interim BLM system lead)
- I. Dolenc Kittelmann (BLM system lead)
- K. Rosengren (FW, DOD)
- H. Kocevar (SW)
- J. Norin (bookkeeping: det. & el. layout, naming)
- S. Grishin (installation)
- C. Derrez (verification plan, QA, electronics)
- E. Bergman (cables, connectors, PPs)
- T. Grandsaert (mech.. Support & integration)

ESS ICS

- F. dos Santos Alves
- (S. Farina)
- (W. Fabianowski)

Interfaces

- Infrastructure
 - Lang haul cables
 - Holes for mech. supports (rails along DTL)
- Vacuum
 - Detector mech. supports on LWUs
- Cryo
 - Detector mounting
- With MPS
 - FBIS (Fast Beam Interlock System)

icBLM: components

Detectors

- Parallel plate gas Ionisation Chambers (ICs) developed for the LHC BLM.
- Beam loss information based on ionisation current measurement of secondaries
- S. Grishin, "icBLM detectors"

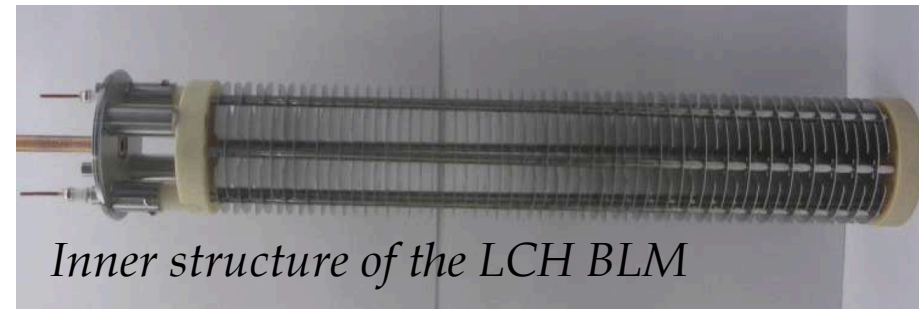

3x3mm² beam, 220MeV on 1st insertion in 1st Spoke cavity, at 1mrad

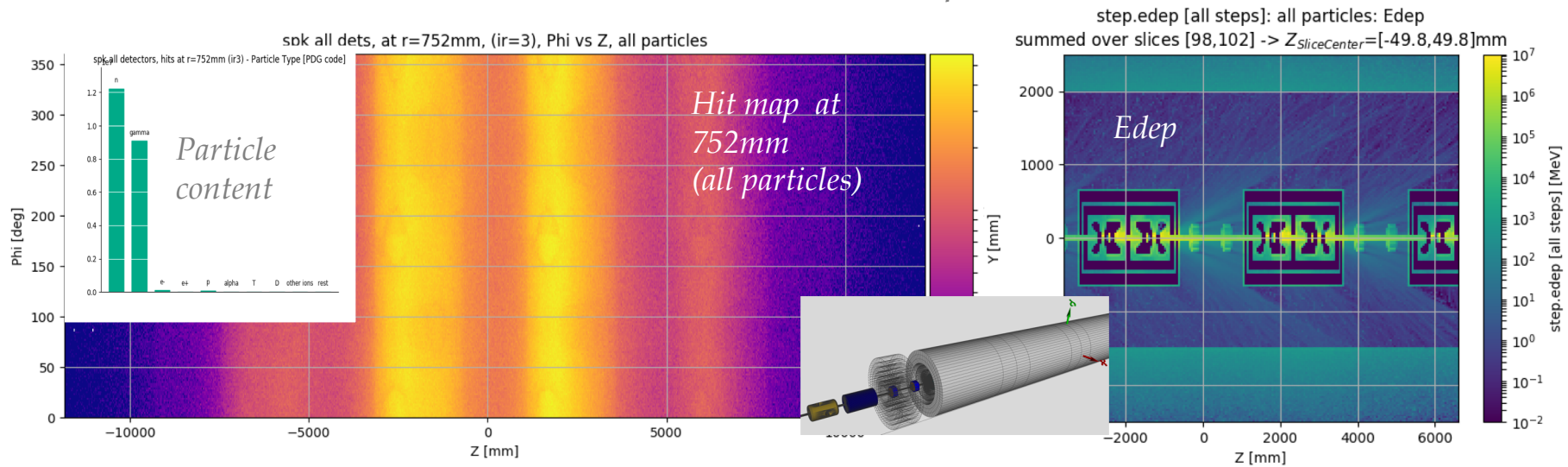

icBLM: components

BEE - final selection

- IOxOS IFC1410 - ICS standard platform
- Pico4, FMC digitizer (CAENels)
 - Modified COTS
 - 1MS/s, 20-bit ADC, 300kHz bandwidth
 - Dynamic range:
 - 0 - 500 μ A,
 - 0 - 10mA
- FBIS interface
 - Piggyback board on RTM, part of ICS standard platform (both still under development)
 - Temporary solution for test purposes: IOxOS DIO3118 FMC
- Low Latency Link
 - SFP+ on RTM
 - Temporary solution: existing RTM from IOxOS

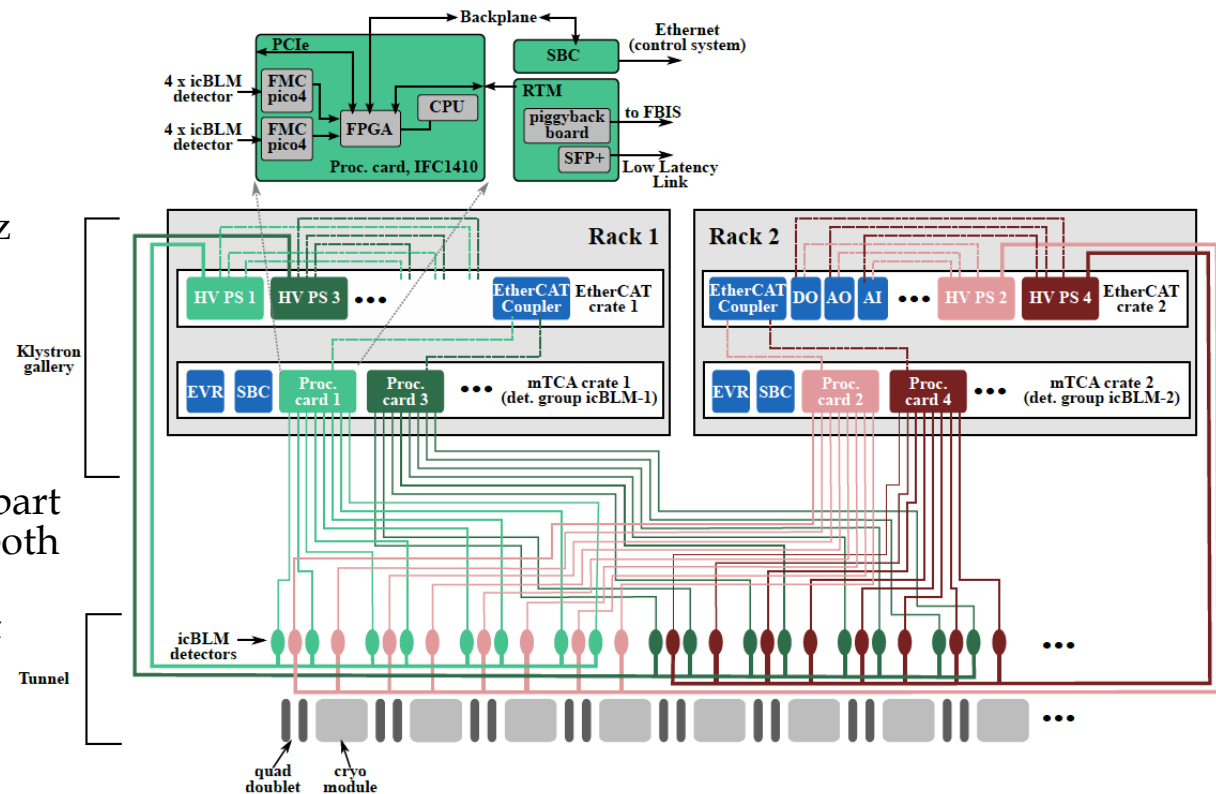

icBLM: components

HV PS

- Provides:
 - Power the ICs (1.5kV) – several ICs are daisy changed and connected to one HV ch
 - Modulation voltage for system HEALTH check.
- HV module (1ch):
 - ISEG DPr 40 305 24 5_CAB High Precision HV-PS
- Ethercat crate with
 - ethercat coupler,
 - DIO (for PS config.) and
 - Analogue module (to modulate)
 - with real time kernel on the CPU.

BEE alternatives

- Digitiser: BLEDP card
 - Developed for CERN injector complex
- Processing board:
 - Struck SIS8300-KU (BLEDP)
 - DAMC-FMC25 (pico4)

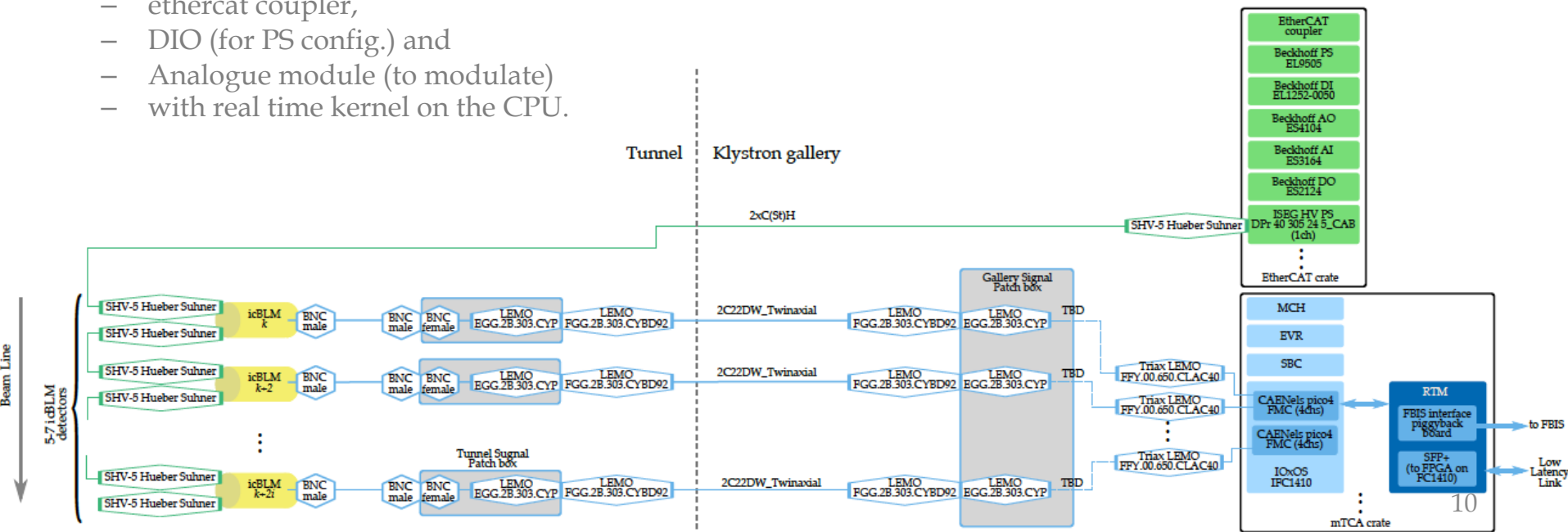

icBLM project: time line

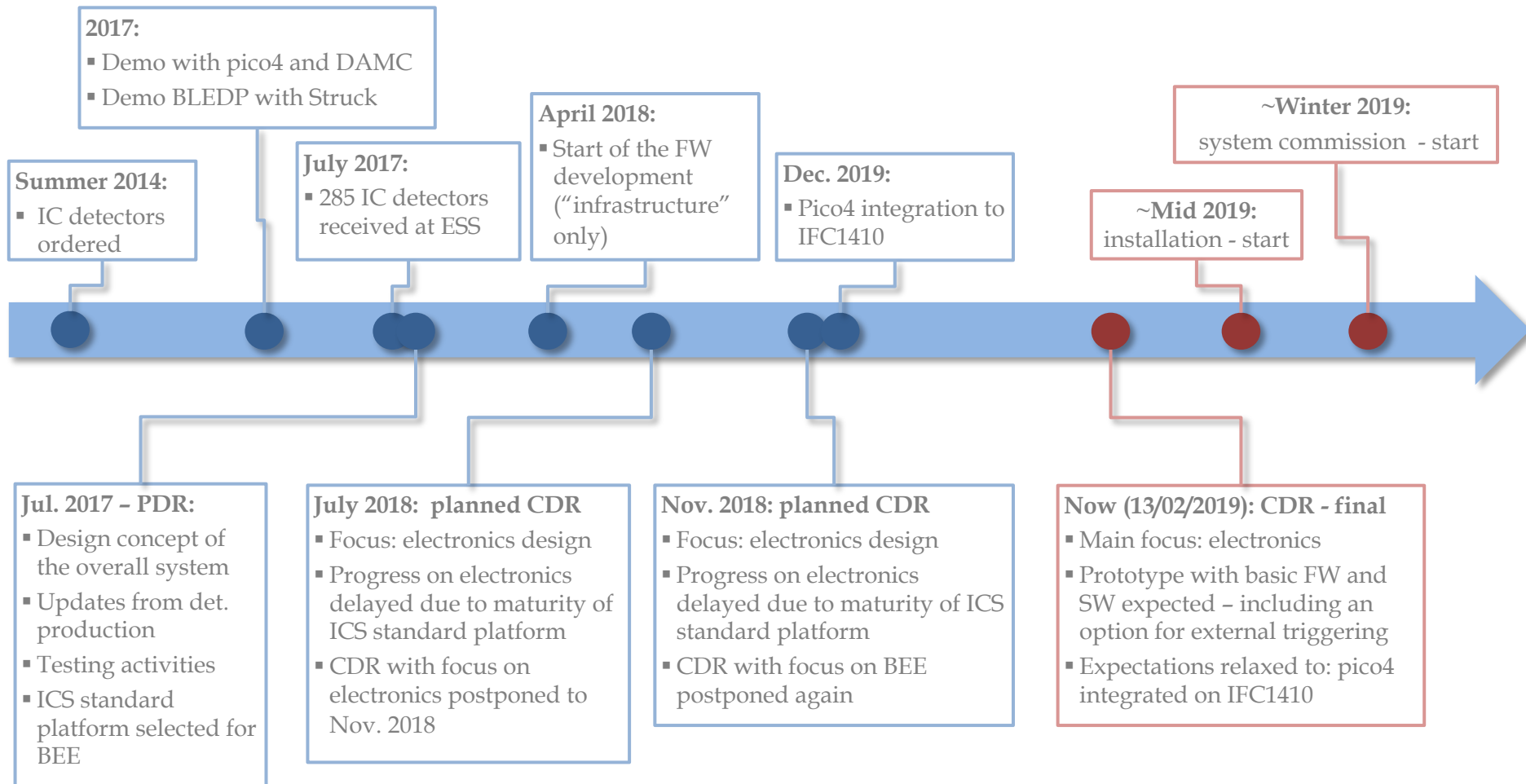

icBLM: FW/SW plan

K. Rosengren, FW/SW development plan (See .xlsx file under the nBLM CDR3 material)

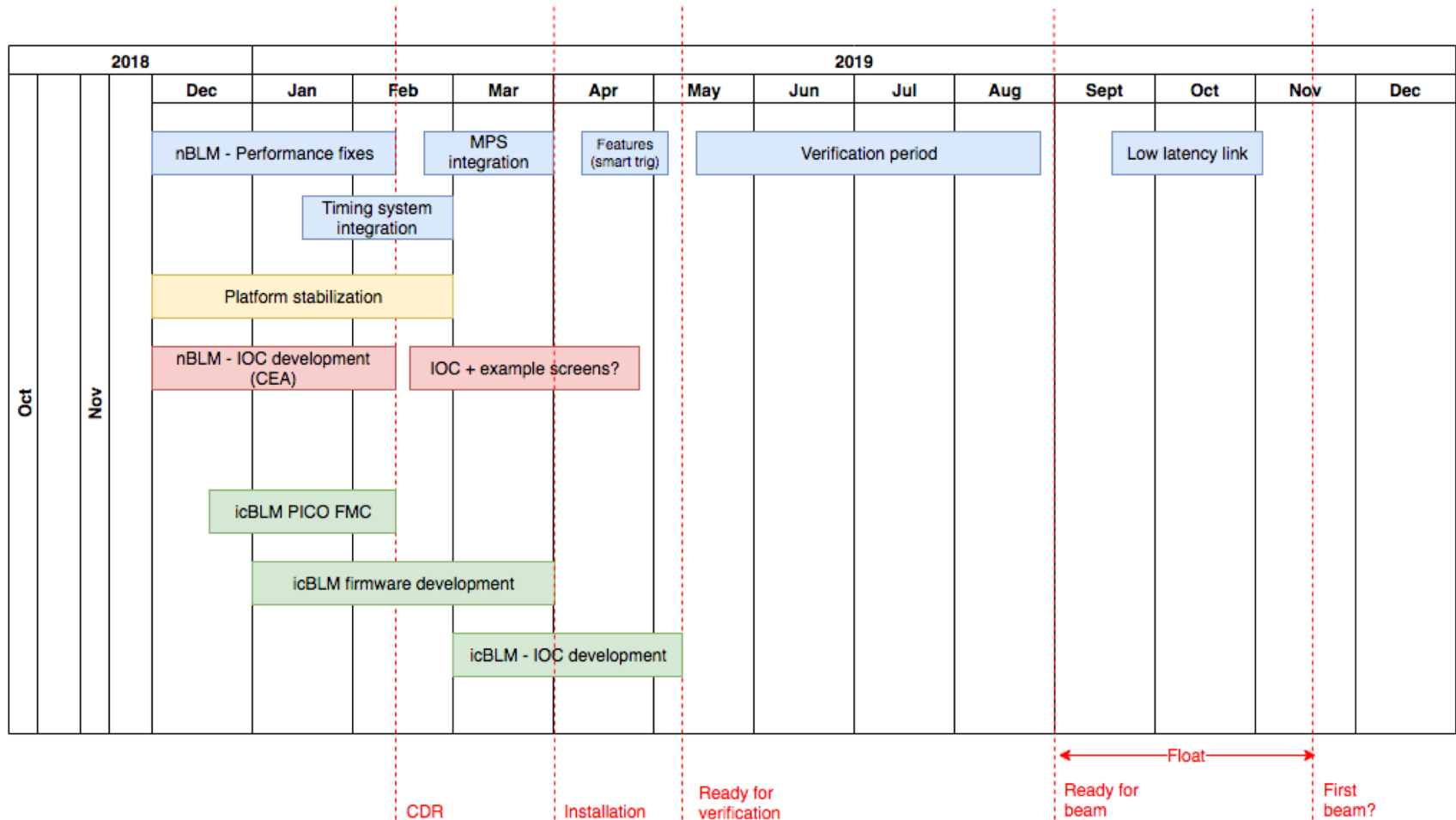

Procurement



See .xlsx file under the icBLM CDR1 material for detailed view (procurement plan, installation time windows for MEBT and DTL1 detectors, system tests, SW and FW development plan)

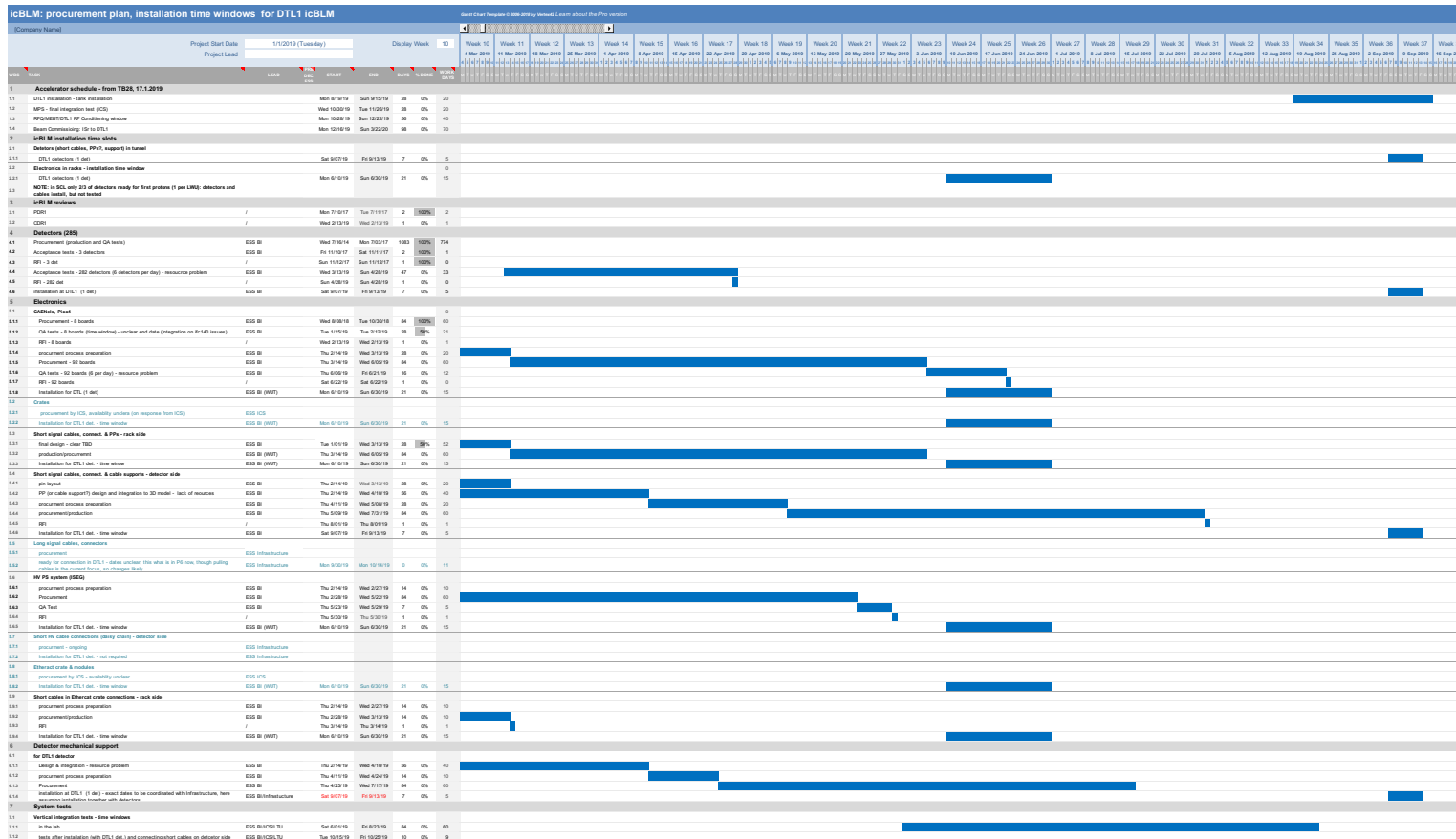

- Detectors produced and delivered.
- Other lead times: no longer than 12 weeks
- For installation DTL1 (1 detector)
 - Almost all parts already available (detector, pico4) or expected in time for planned installation slots.
 - Note that electronics installation time window (crates, cards, short cables) pushed to as earlier date as possible to have it done before summer
 - Risks:
 - Availability of crates (ICS) – unclear, but considered lower risk
 - Long and part of short cables available for installation (Infrastructure) – dates unclear, but considered lower risk
 - Some cabling details TBD (pin layouts, short signal connections on the rack side) – considered low risk
 - DTL detector support design and integration to 3d model – lack of resources
 - Detector and support installation – dates to be coordinated with Infrastructure

icBLM CDR1 - charge

- Supporting documentation available on top of the agenda sicne Monday 5/2/2019:
<https://indico.ess.lu.se/event/1173/>
- CDR1 Charge:
 - icBLM overall system.
 - Main focus: electronics.

*Back up
material*

ESS Beam Loss diagnostic tools

(from T. Shea)

- **Total beam loss**, microsecond measurement latency required for protection
 - BCM, icBLM (saturation, nBLM (current mode) → Interlock; Threshold/derivative term for fast protection
- **> 1.6 milliamp lost for up to 200 μ s**
 - BCM, icBLM, nBLM → Interlock; Damage model for protection
- **$\sim \mu$ C lost over 200 μ s to many seconds** (diffusion time)
 - icBLM, nBLM → Interlock; Damage model for protection
- **\sim “1 Watt/meter” radiation dose management**
 - icBLM, nBLM → alarm based on dose/activation plan

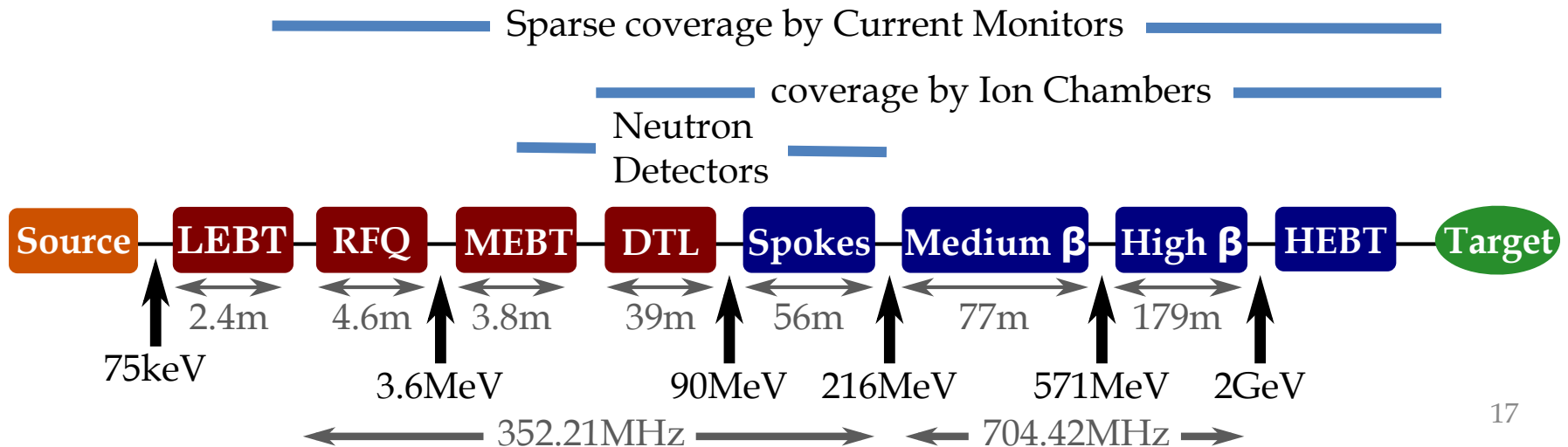

ESS BLM: Response time

- Required response time set in the past:
 - NC linac (MEBT-DTL): $\sim 5 \mu\text{s}$.
 - SC linac: $\sim 10 \mu\text{s}$.
 - Numbers based on a simplified melting time calculations, where a block of material (copper or stainless steel) is hit by a beam of protons with a uniform profile under perpendicular incidence angle, no cooling considered [9].
- Numbers re-checked with a Gaussian beam and update beam parameters:
 - **NC linac:** calculated melting time values of $3\text{-}4\mu\text{s}$ imply even stronger demands on the response time (confirmed with a MC simulation as well).
 - **SC linac:** the $10\mu\text{s}$ requirement for response time fits well with the results of this calculations.However: other damage mechanisms may mandate even shorter response time SCL (discussed further).

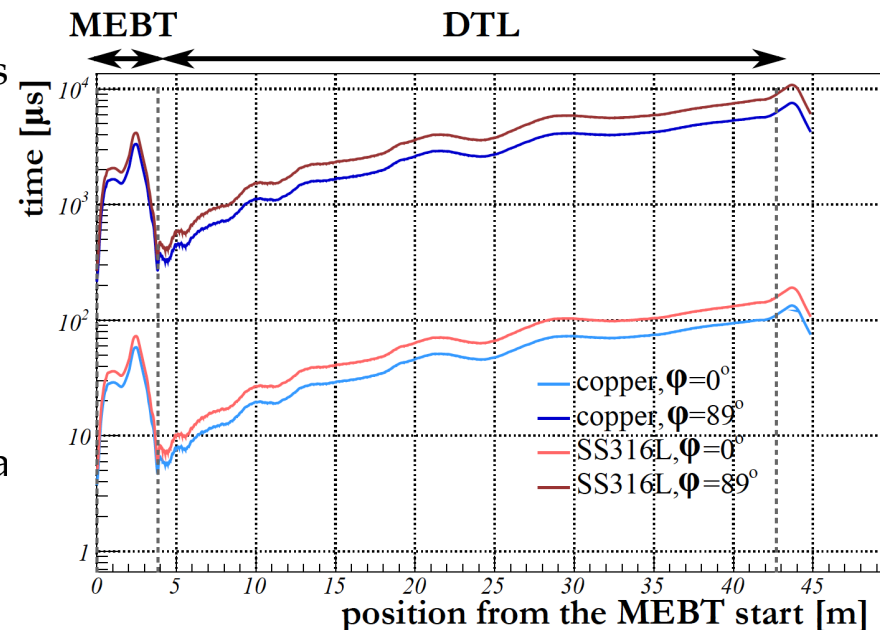

ESS BLM: beam loss simulations

- **MC simulations for tracking of lost protons needed to determine**
 - Detector locations, system response time and dynamic range
 - Expected particle fields, signals
 - Initial MPS threshold settings at the startup and later adjustments
 - Anticipated response of the system during fault studies - to verify and calibrate the system response

- **Required inputs**
 - Ideally
 - Expected loss maps during normal operation
 - A list of accidental beam loss scenarios with loss maps
 - Elements to be protected, damage levels
 - Large number of possible accidental scenarios: simplifications/assumptions needed

- **Simulation tool**
 - Geant4 simulation framework developed by the ESS neutron detector group
 - Geant4 based ESS linac geometry created (current version: DTL - HEBT)

ESS BLM: MC simulations - linac geo

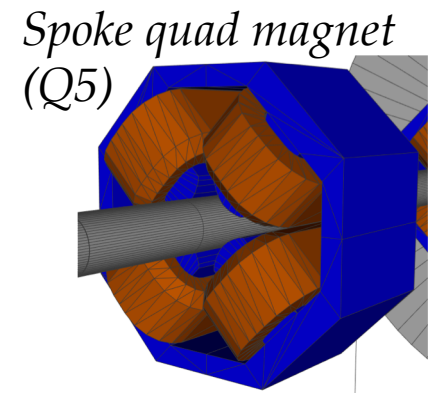
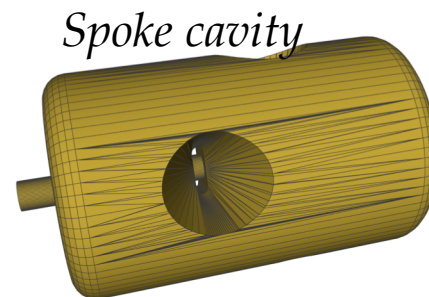
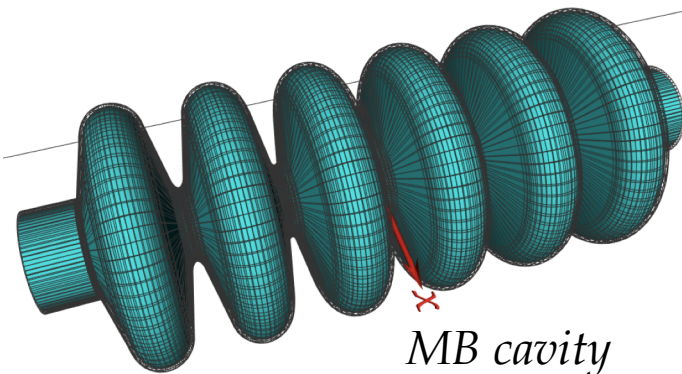
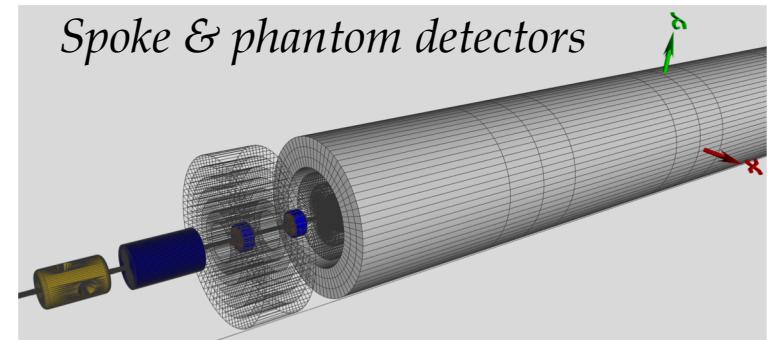
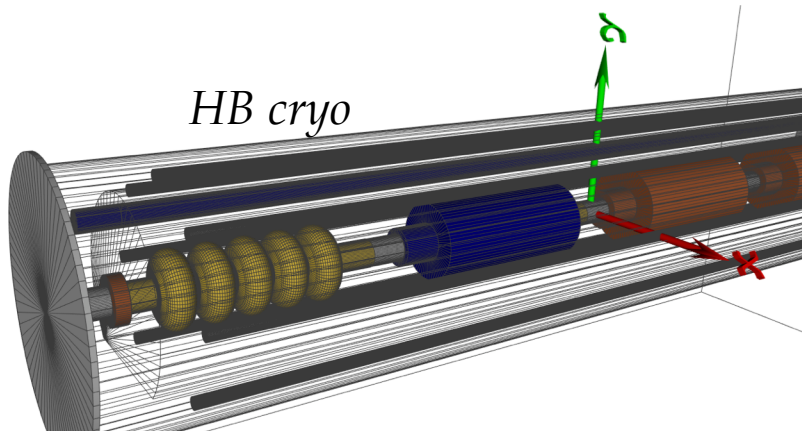
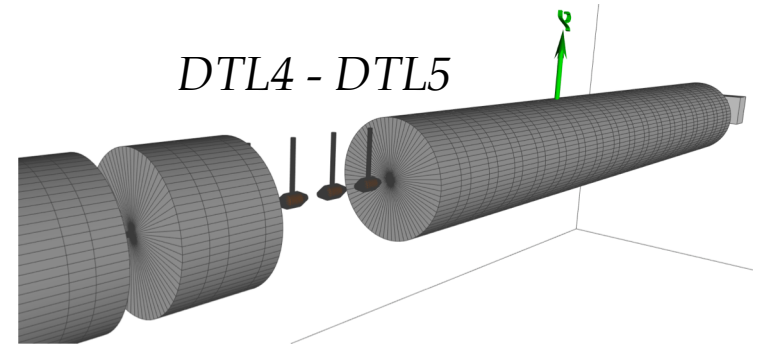
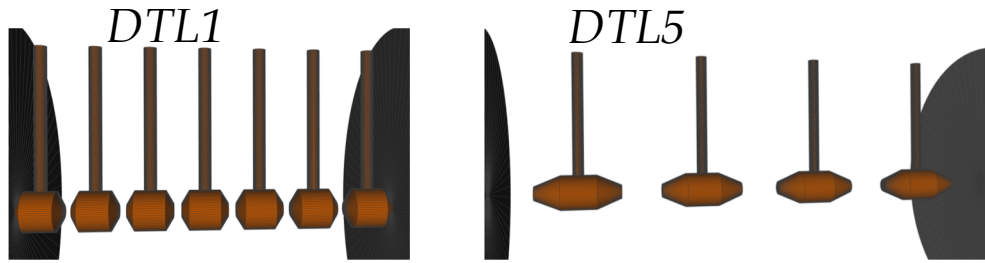

ESS BLM: MC simulations

Past studies

- Focused on DTL
- Tanks surrounded with “phantom detectors”
- Loss scenarios:
 - Accidental losses: scanned over various configurations of energy, beam size, hit angles and position along the DTL
 - Uniform loss, 1W/m loss
 - Nominal operation
- Studied:
 - Expected particle fields (type, energy, fluxes along the beam line)
 - Correlation between the loss location (center) and peak position in neutron hitmaps
 - Spread (RMS) of neutron hitmaps
 - Threshold energy to discriminate fast/slow neutrons
- Tasks:
 - Support nBLM detector design, results used
 - As inputs to MC simulations to optimize detector design
 - For signal estimations
 - nBLM detector layout

Sim2-9: loc. loss at the beginning of the DTL5 (histogram normalized per number of primaries): hitmap mean=-2.76m Gauss fit mean = -3.56m Peak visible ~3.5m

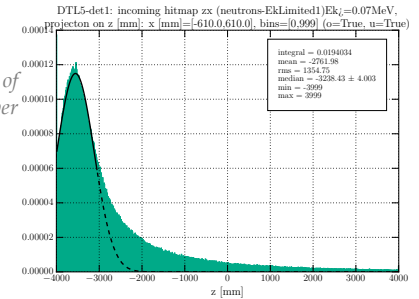

Neutron hitmaps with $E_k > 0.5$ MeV cut: difference between the hitmap mean and the loss position

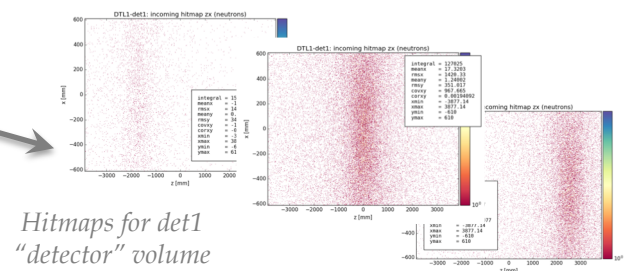
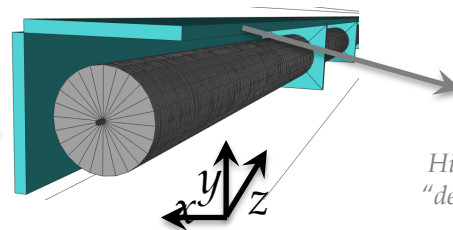
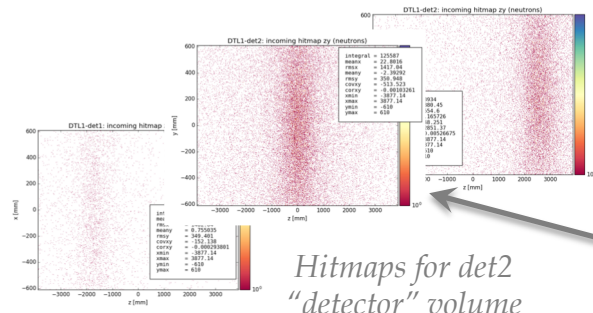
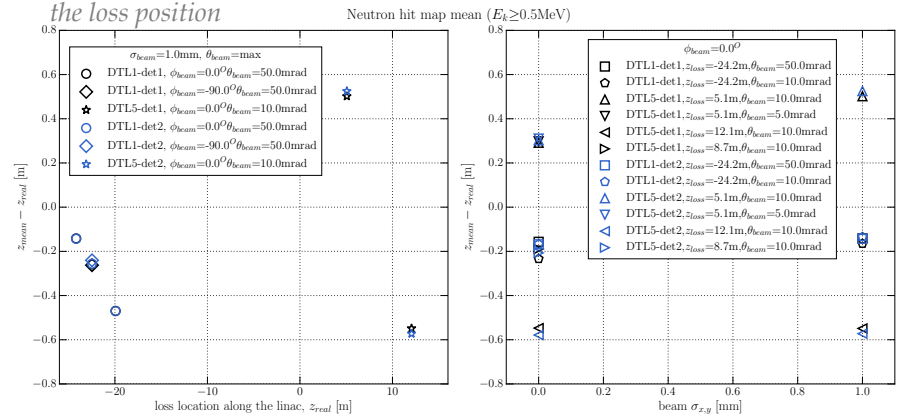

Current focus

- Cold linac
- Loss scenarios:
 - Scanned over various for various configurations of energy, beam size, hit angles and position along the cryo modules or quads
 - Uniform loss, 1W/m loss
 - Nominal operation
- Tasks:
 - Expected particle fields (type, energy, fluxes along the beam line)
 - Estimate signals/rates
 - Correlation between loss location and peak in distributions (hitmaps, Edep) & spread
 - Starting point for further studies
 - Determination of loss location (loss pattern) from the measurements (ANNs?)
 - MPS Thresholds

ESS BLM: MC simulations

Example: energy deposition summed over 4 center slices along x

- 220MeV protons,
- Beam center hits inside a Spk cryo: on 1st insertion in 1st Spoke cavity
- Theta=1mrad

Pencil beam

step.edep [all steps]: all particles: Edep
summed over slices [98,102] -> $Z_{\text{SliceCenter}}=[-49.8,49.8]\text{mm}$

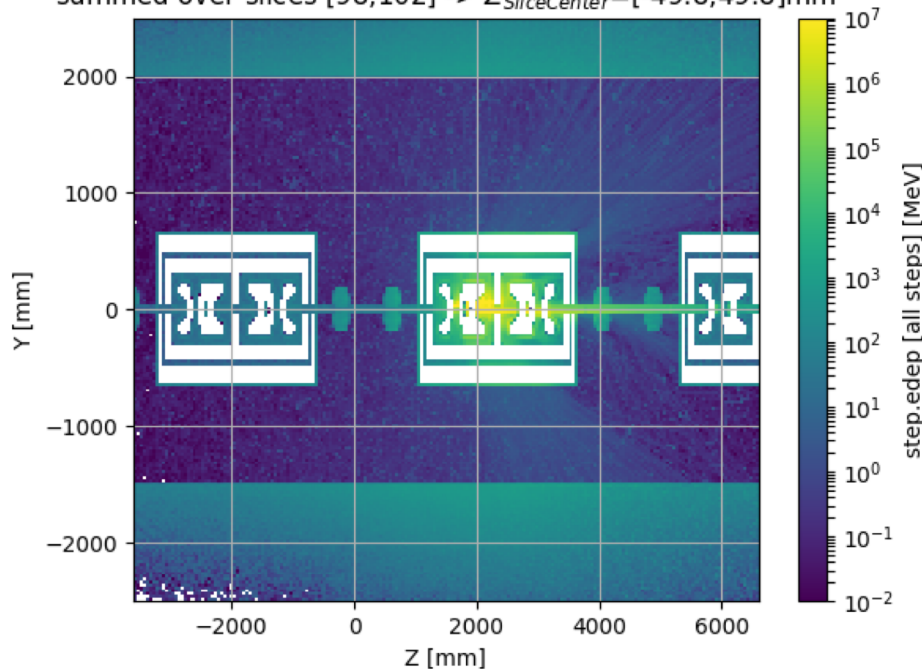

3x3mm² (gaussian) beam

step.edep [all steps]: all particles: Edep
summed over slices [98,102] -> $Z_{\text{SliceCenter}}=[-49.8,49.8]\text{mm}$

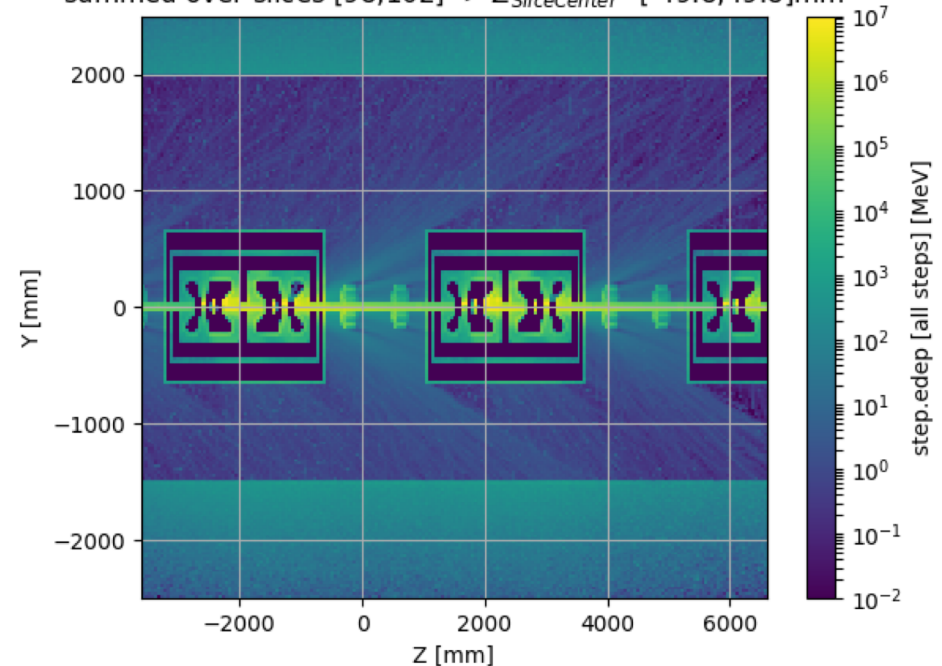

ESS BLM: MC simulations

Example:

- 220MeV protons
- Hit center inside Spk cryo at 1st insertion in 1st Spk cavity (z=1650mm)
- Theta=1mrad

Plots:

- Phi vs Z for particles at r=752mm from the beam axis
- Particle types (n, gamma, e-,...)

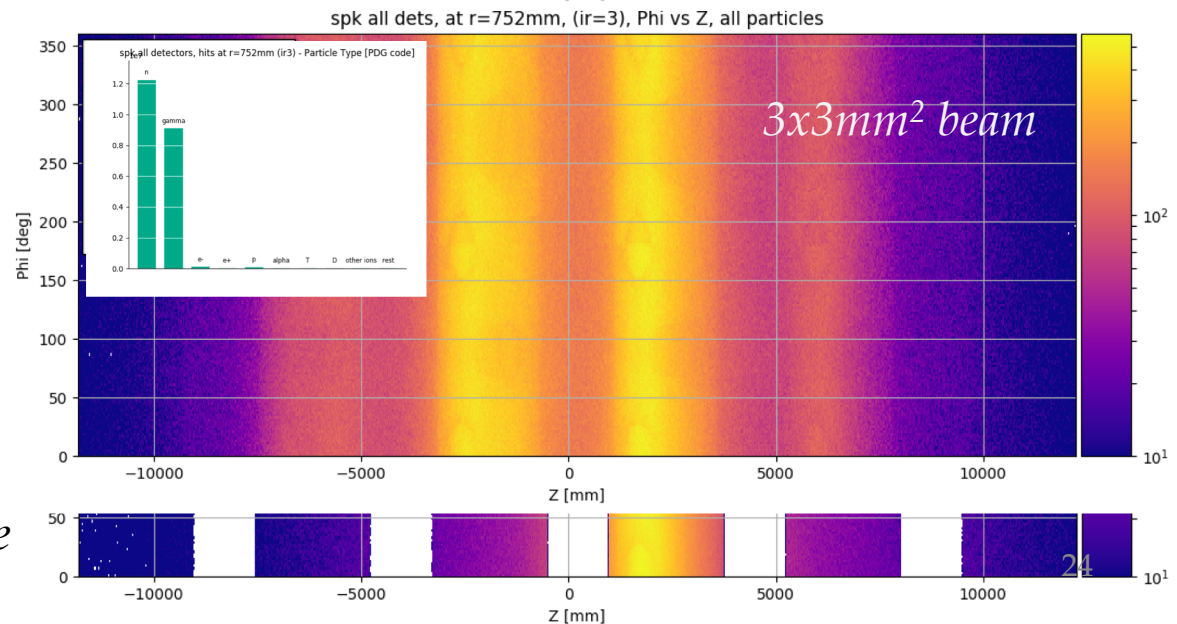
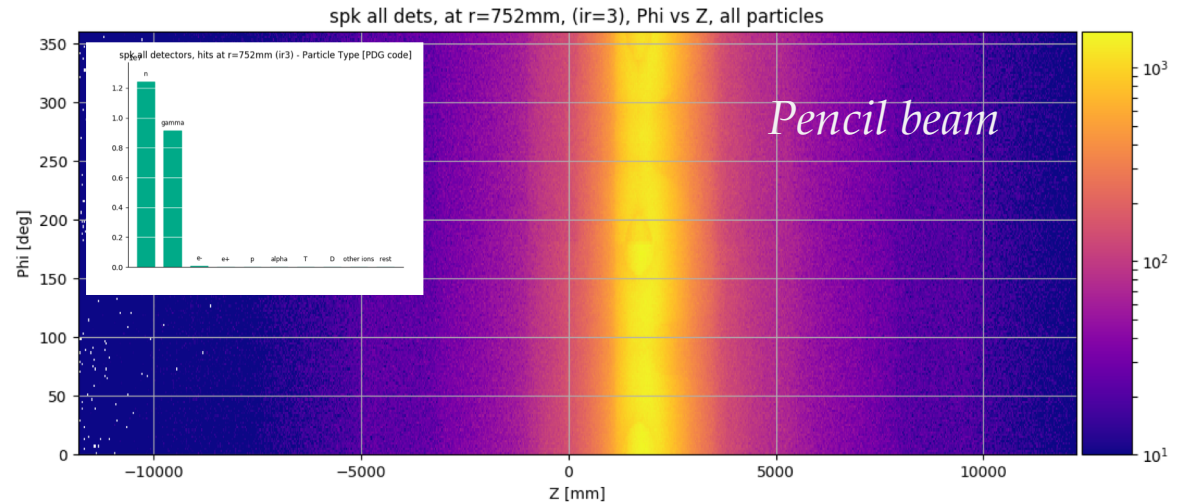

*Cryo module
positions*

ESS BLM: MC simulations

Example:

- 220MeV protons
- Hit at: 1st insertion in Spk cavity
- Theta=1mrad
- Pencil beam

Plots: hits at r=752mm from beam axis

- Neutron and photon energy along the beam line

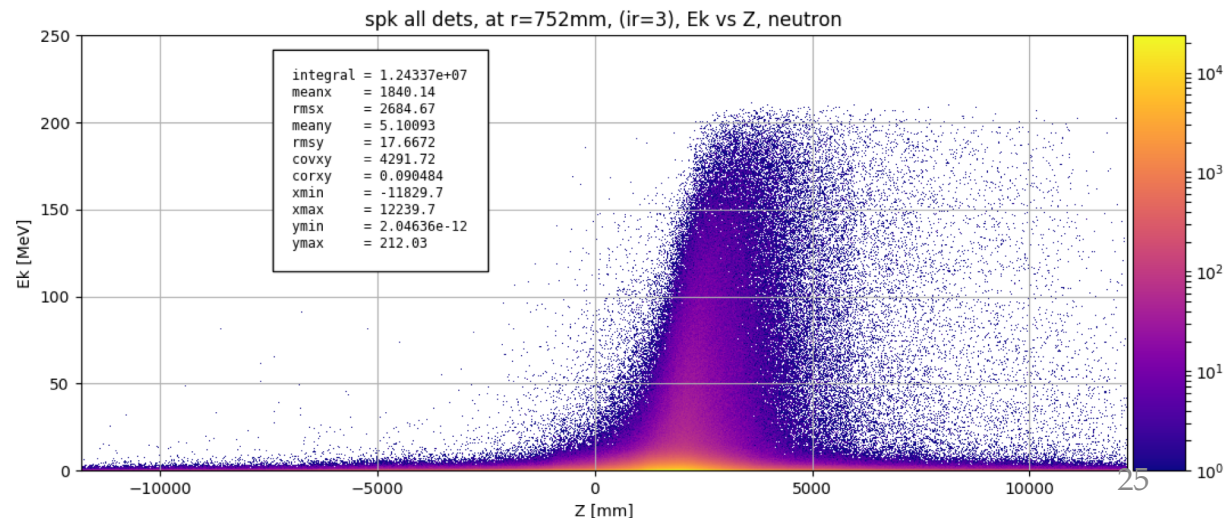
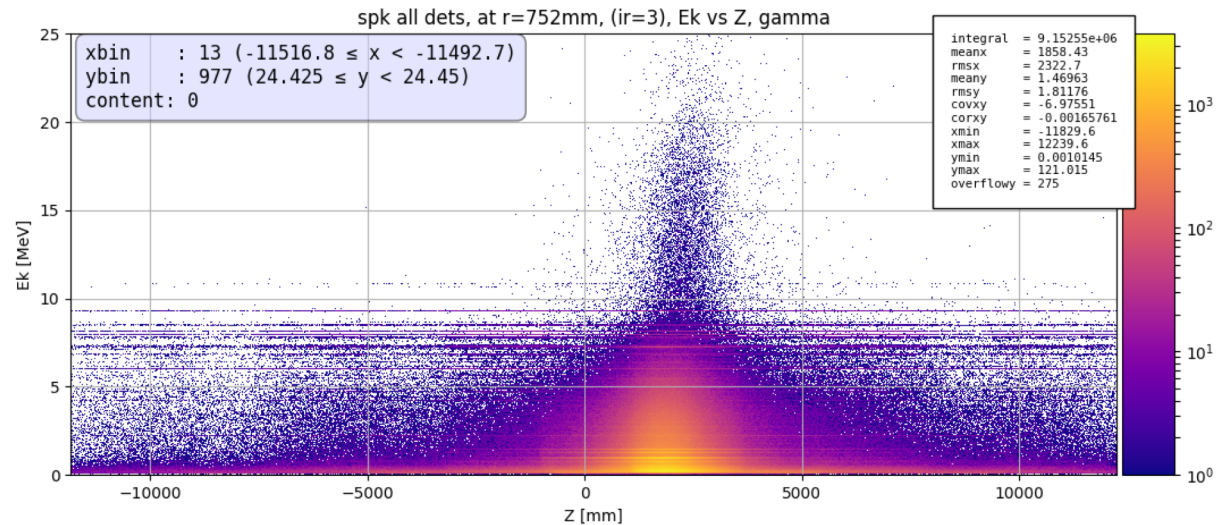

ESS BLM: MC simulations

Example:

- 220MeV protons
- Hit at: 1st insertion in 1st Spk cavity
- Theta=1mrad
- 3x3mm² beam

Plots: hits at r=752mm from beam axis

- Neutron and photon energy along the beam line

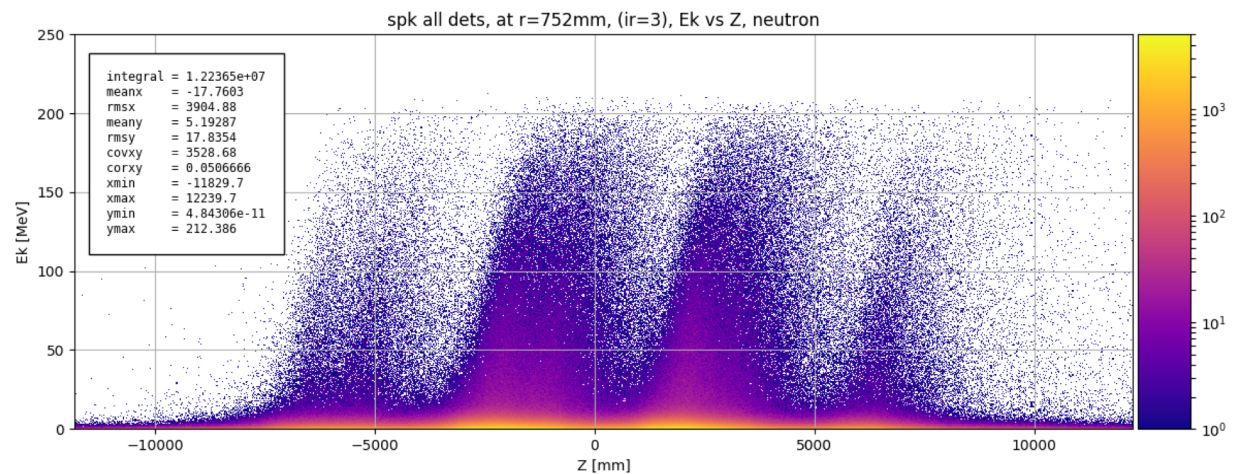
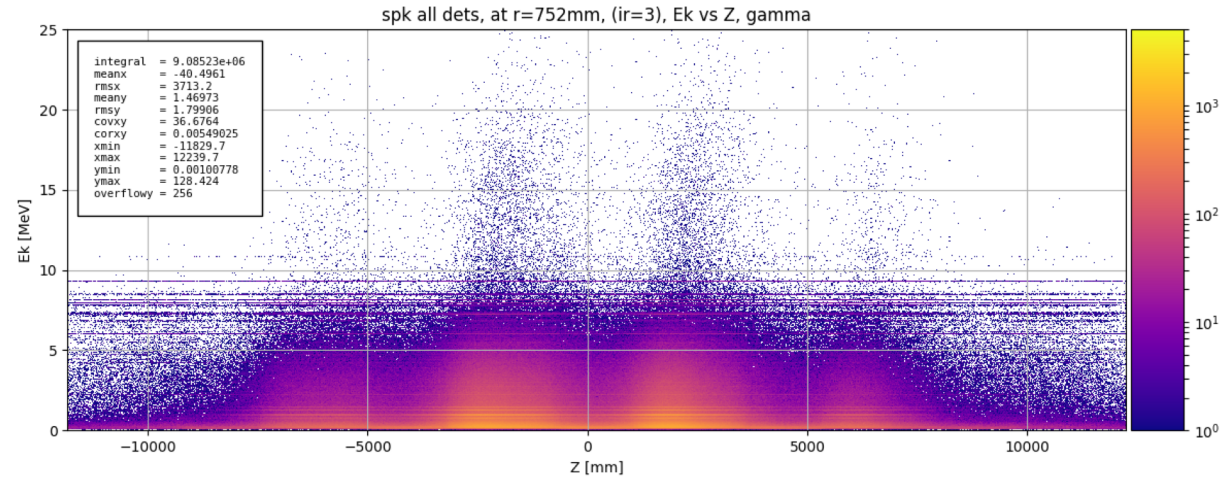

ESS BLM: detector layout (MEBT-MB)

nBLM-F vs. nBLM-S

- Majority of the linac: F and S placed separately in an alternating fashion
- At certain locations: a pair of F & S device

Normal conducting linac (NCL):

- nBLM:
 - MEBT: 4 devices (nBLM)
 - DTL: ~ 1 device / 1m
- icBLM:
 - DTL: 1device/tank

Superconducting linac (SCL):

- nBLM
 - Spoke: 1 device / 2m
 - Sparsely located in other parts of SCL
- icBLM:
 - 3/quad pairs
 - 1/cryo

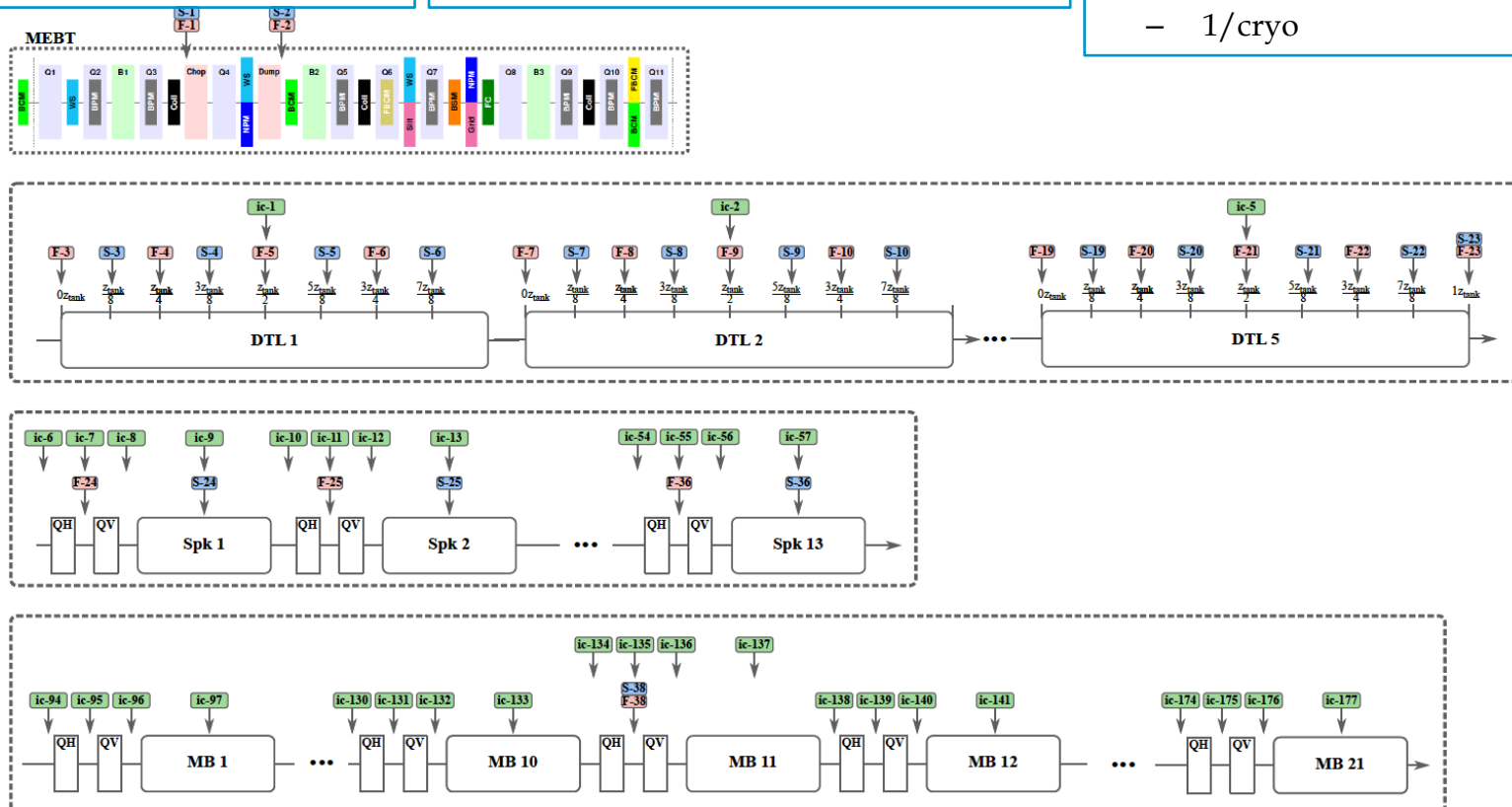

ESS BLM: detector layout (HB – end)

nBLM-F vs. nBLM-S

- Majority of the linac: F and S placed separately in an alternating fashion
- At certain locations: a pair of F & S device

Normal conducting linac (NCL):

- nBLM:
 - MEBT: 4 devices (nBLM)
 - DTL: ~ 1 device / 1m
- icBLM:
 - DTL: 1device/tank

Superconducting linac (SCL):

- nBLM
 - Spoke: 1 device / 2m
 - Sparsely located in other parts of SCL
- icBLM:
 - 3/quad pairs
 - 1/cryo

