



# **ODIN: Optical and Diffraction Imaging with Neutrons at the ESS**

Technical and design update

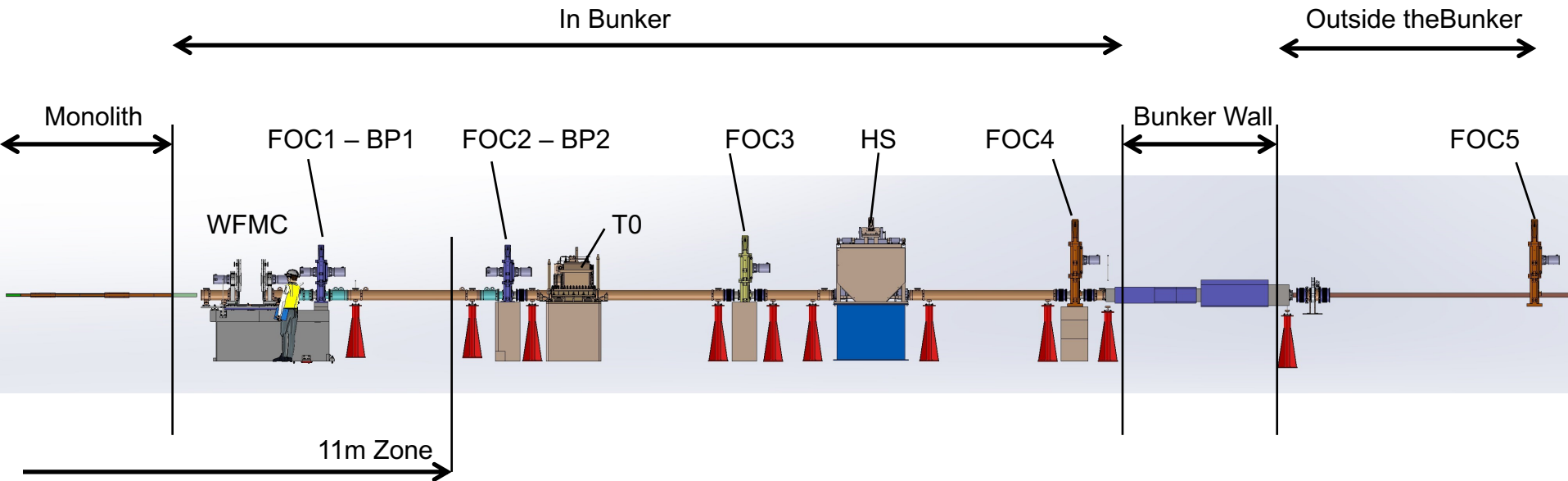
**PSI:** M. Morgano, M. Strobl

**TUM:** E. Calzada, A. Tartaglione, M. Schulz

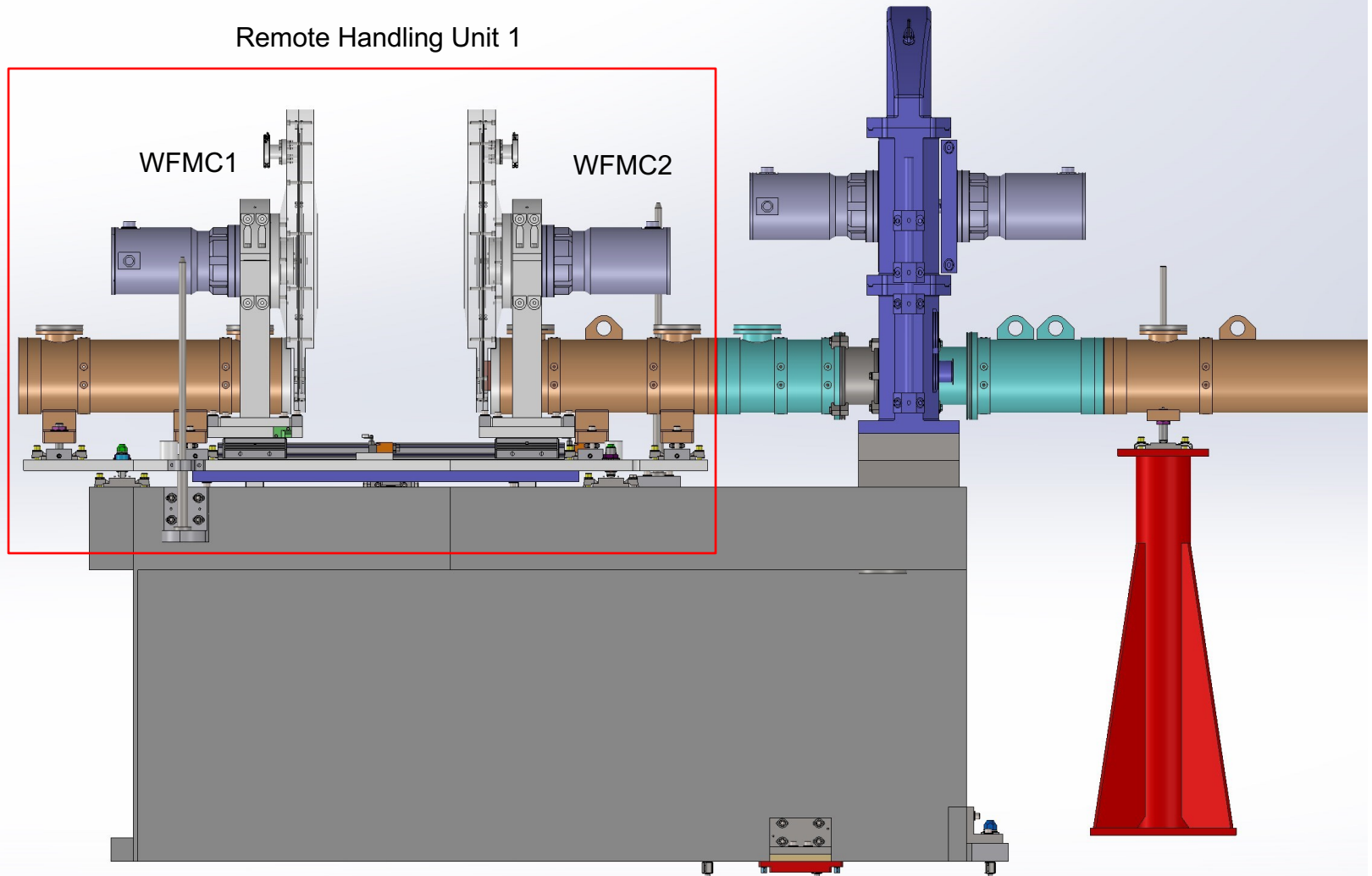
# Outline

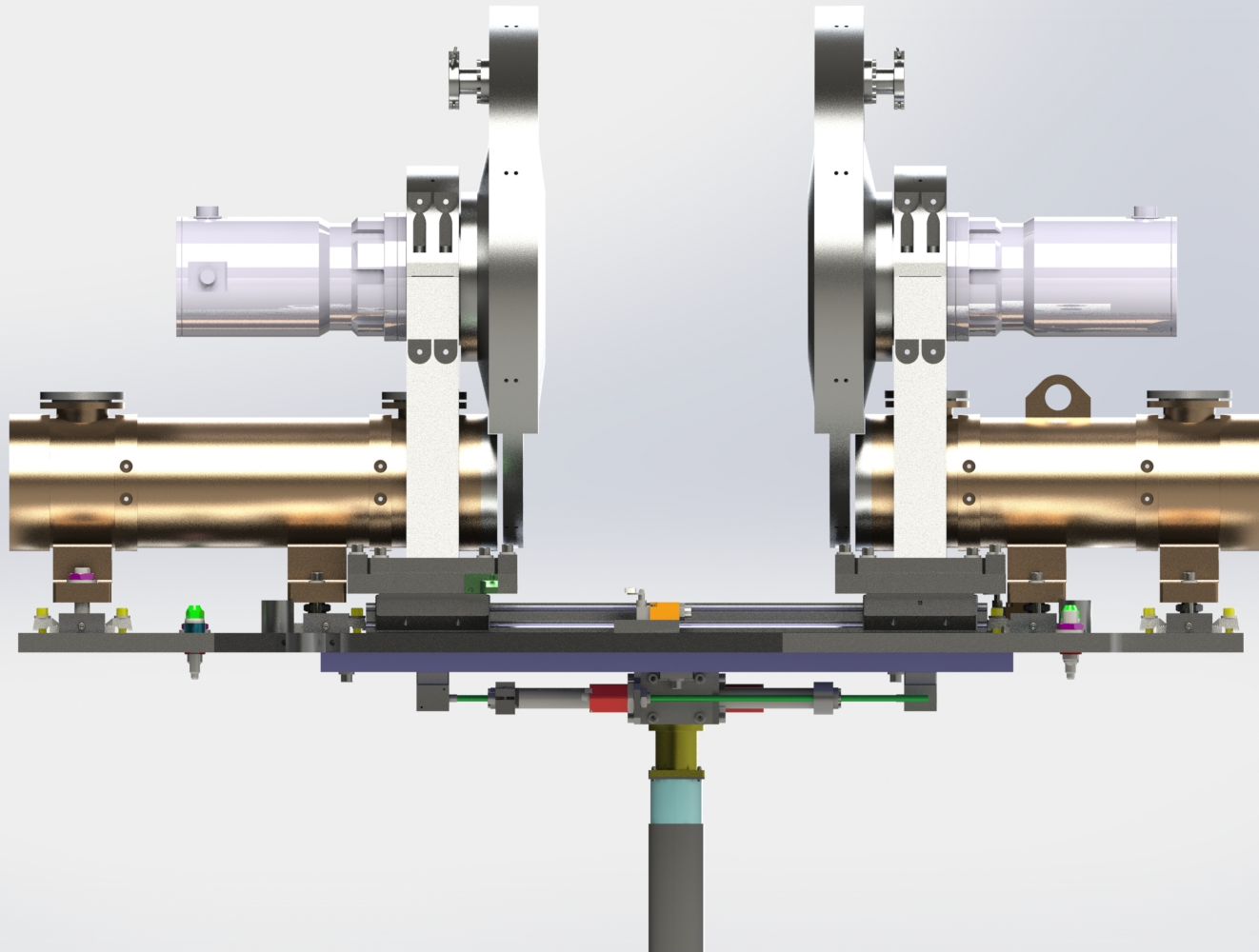
- ODIN Technical Design update in Bunker
  - WFMC
  - T0 Chopper
  - Heavy Shutter
- ODIN Technical Design update outside the Bunker
  - Cave – MCNP Results - Technical design
  - Control Hutch
  - Neutron guide Shielding interface

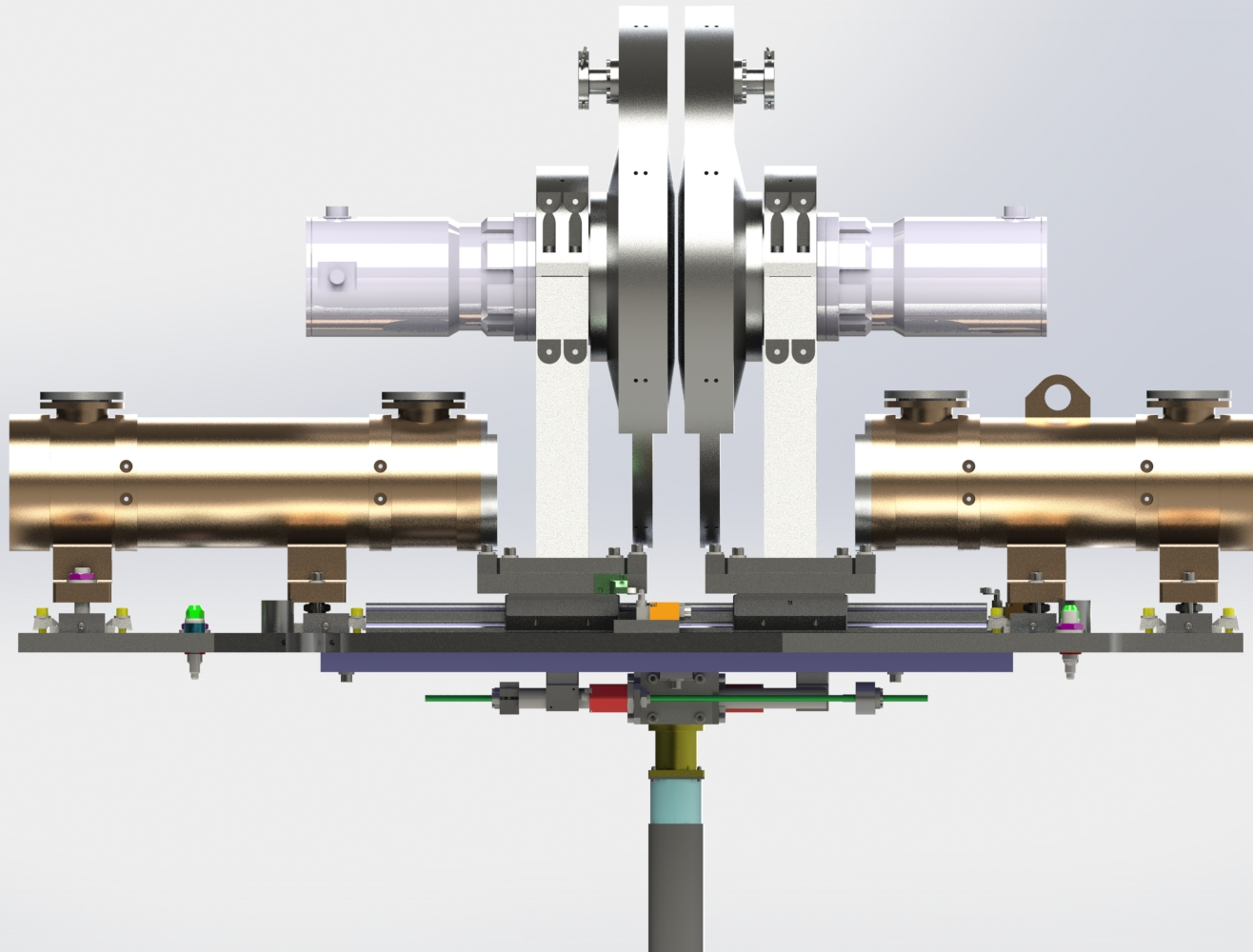
# Instrument design in Bunker

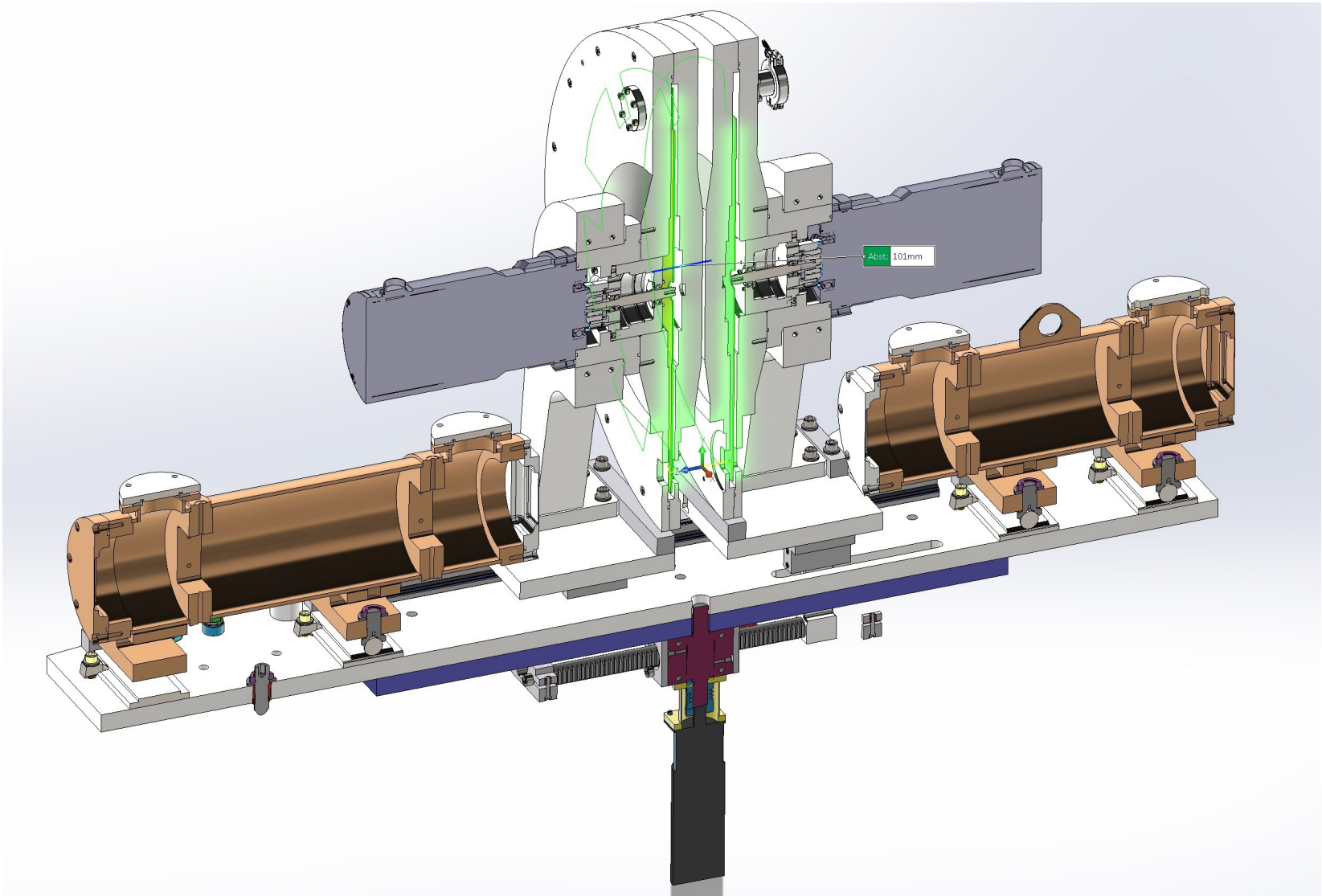


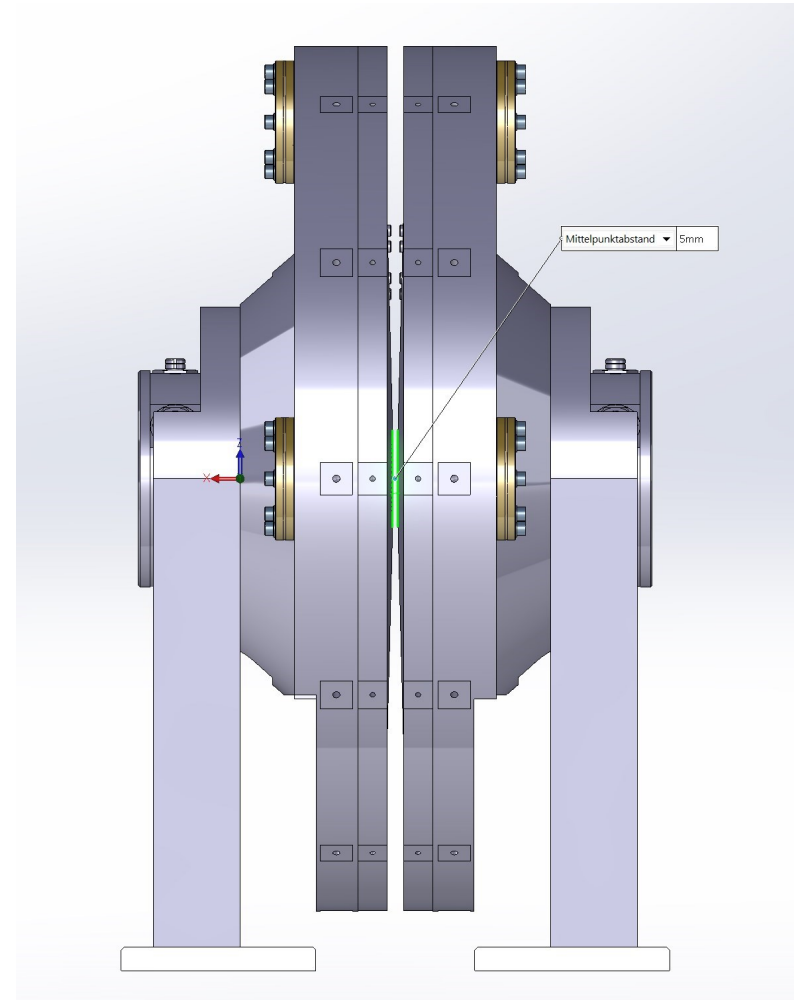
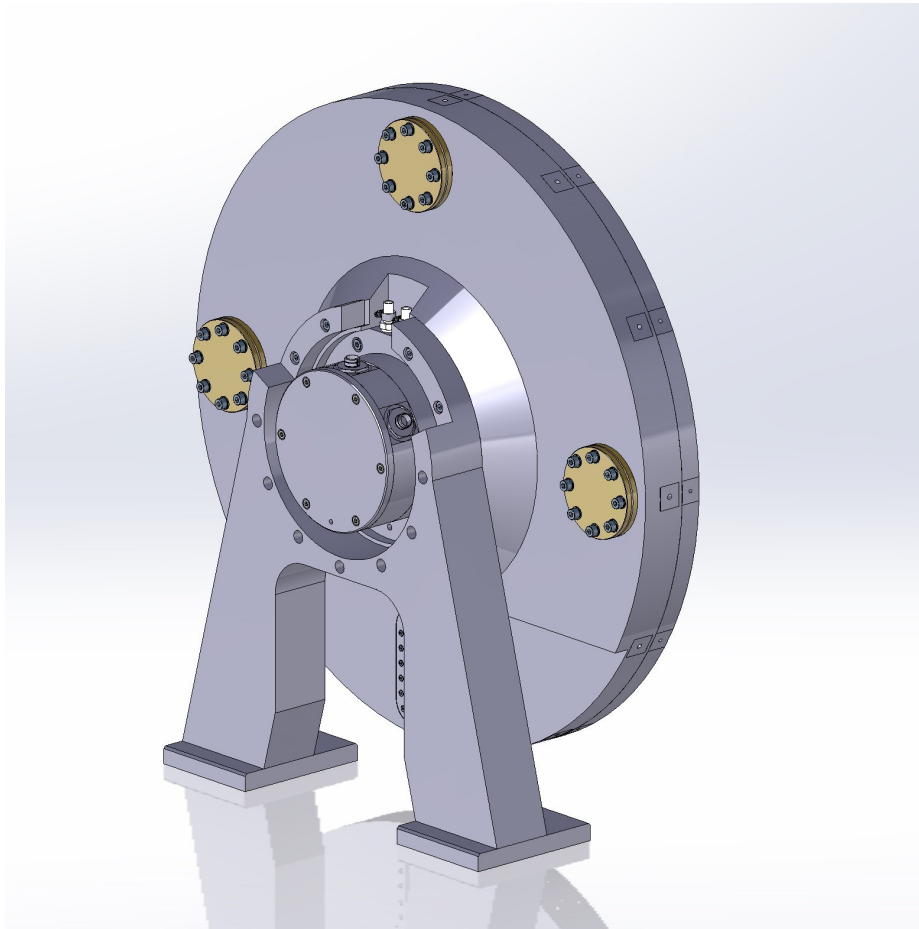
### Remote Handling Unit 1

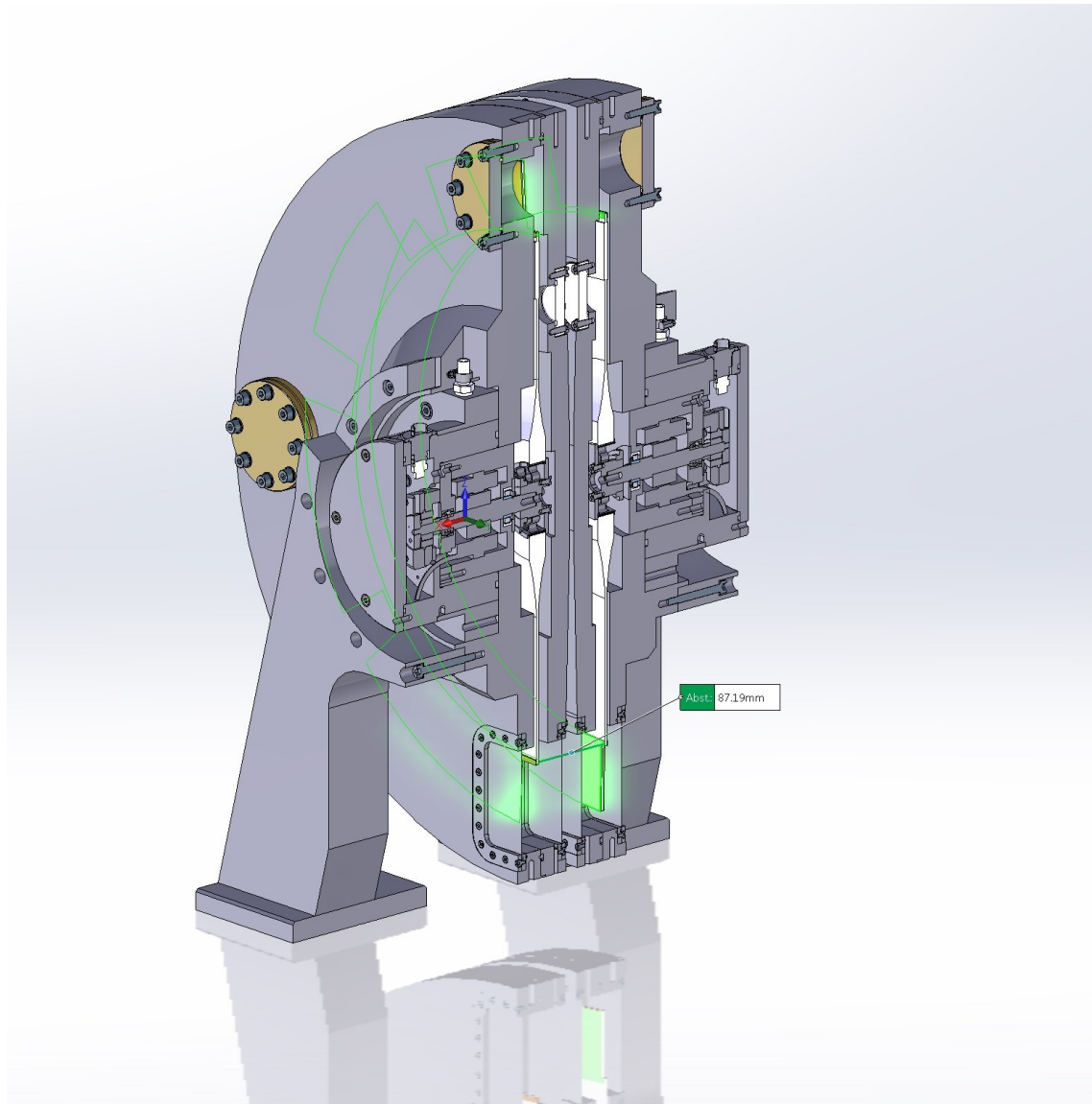


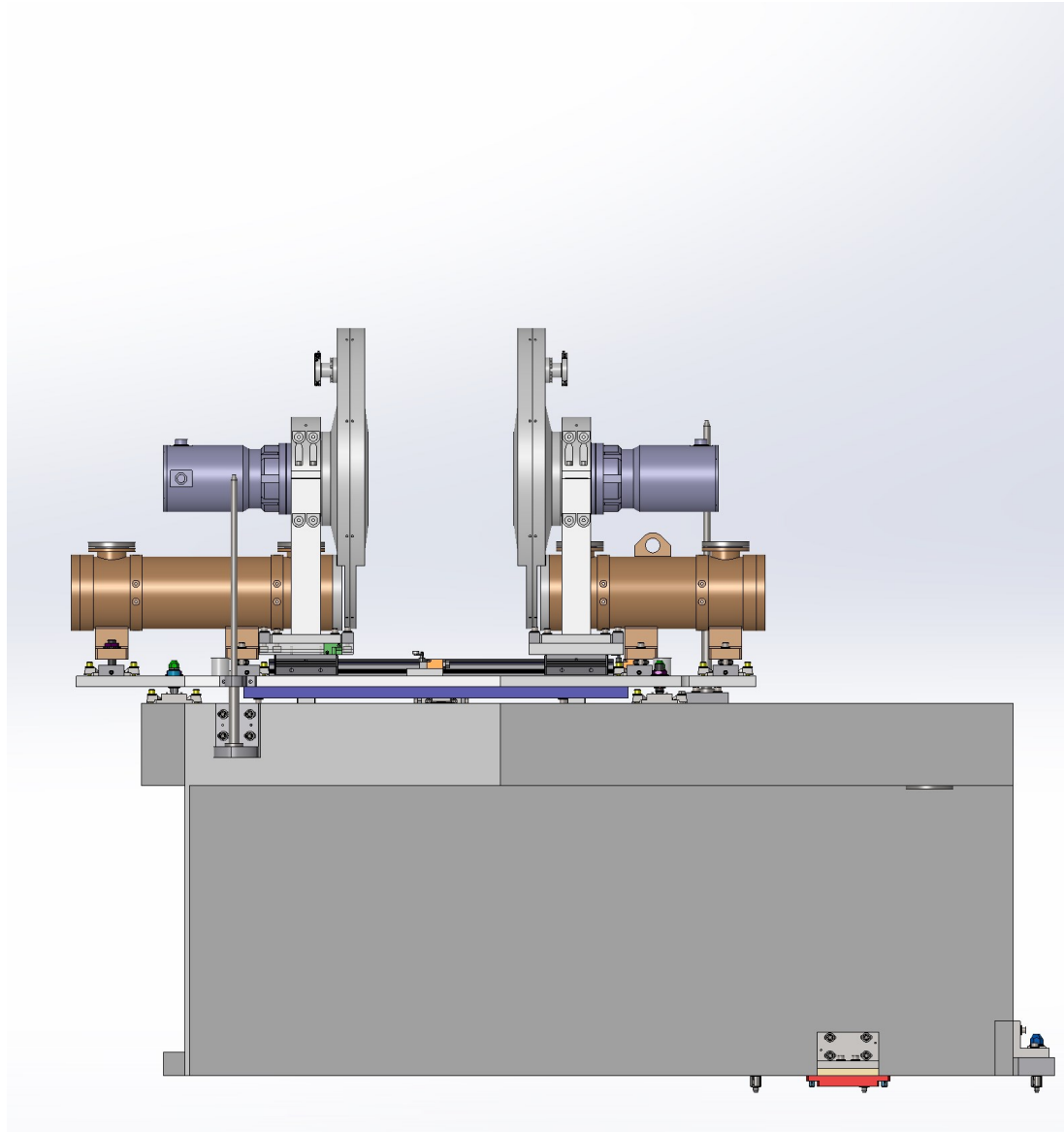


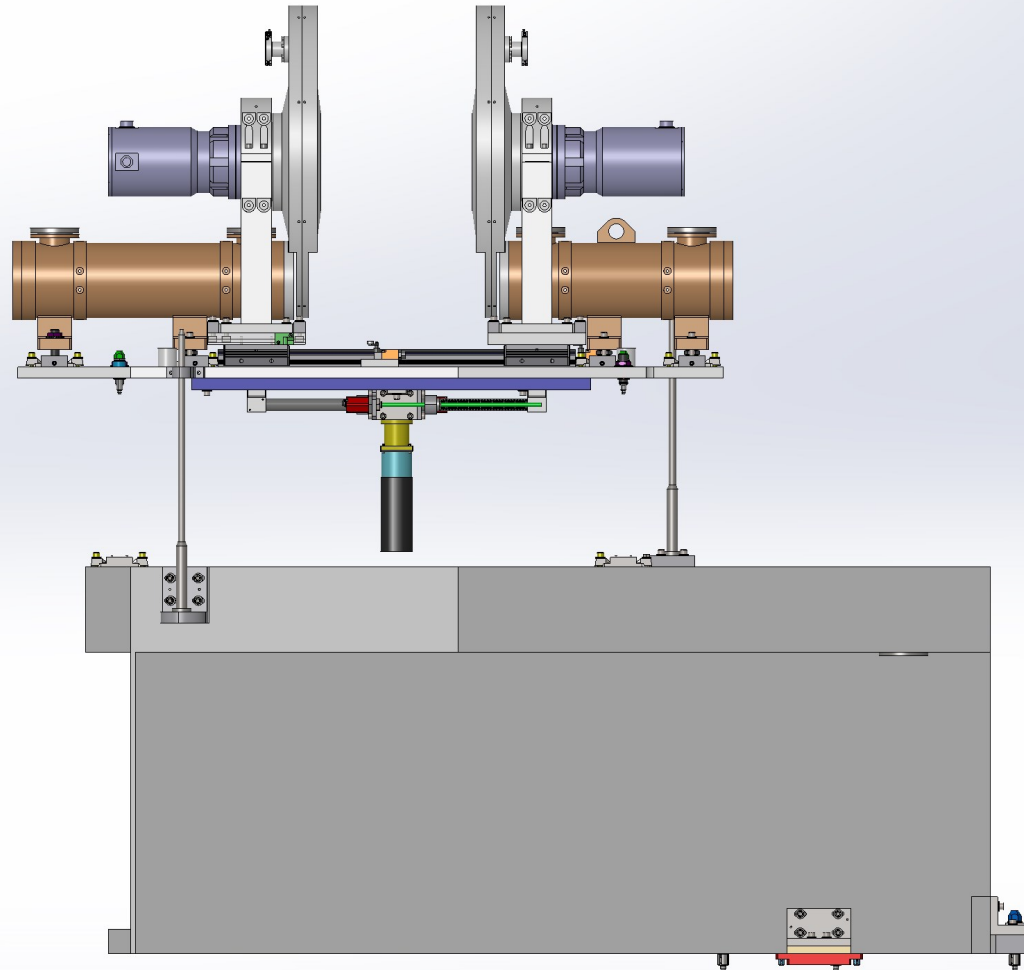


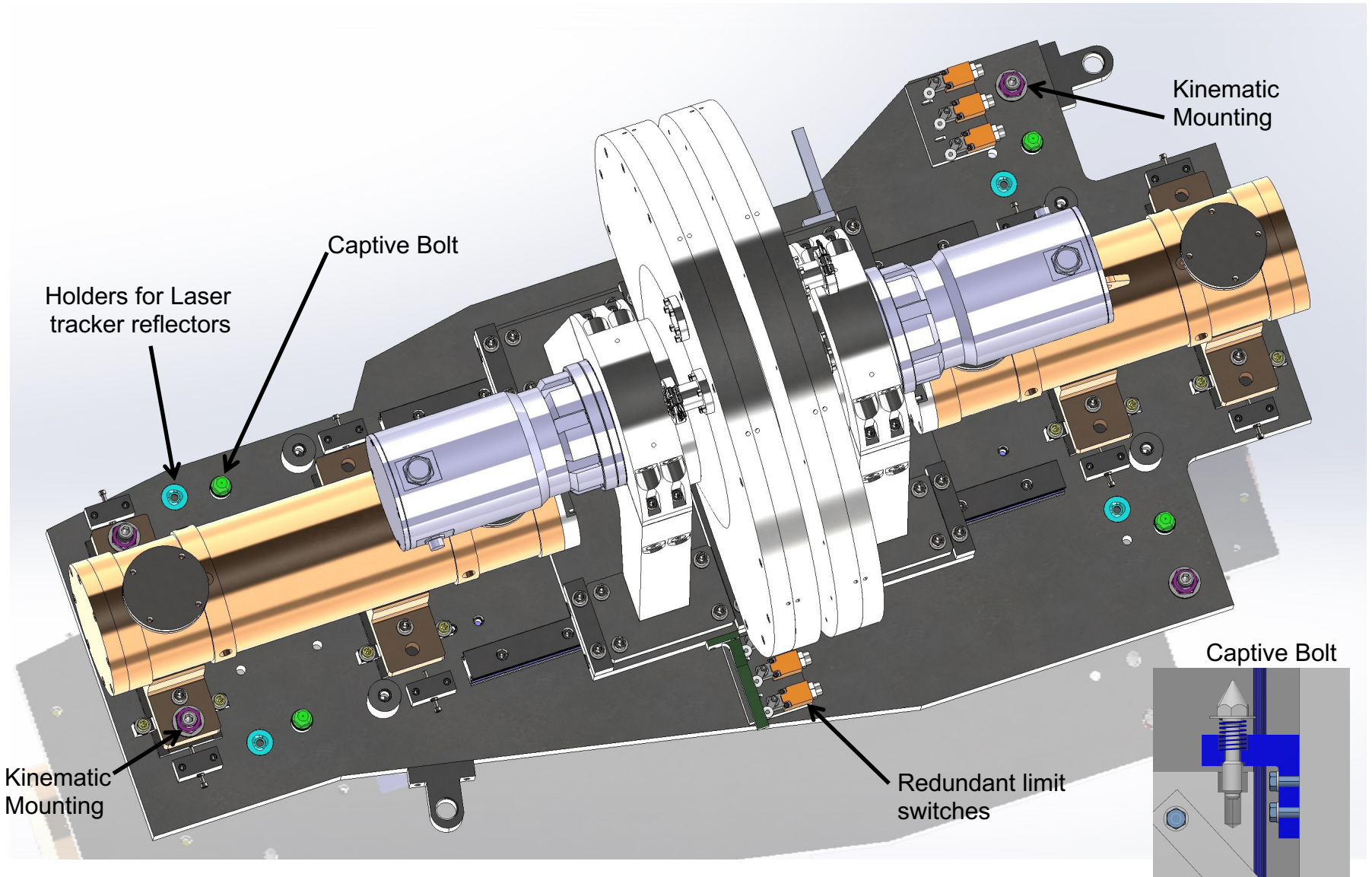


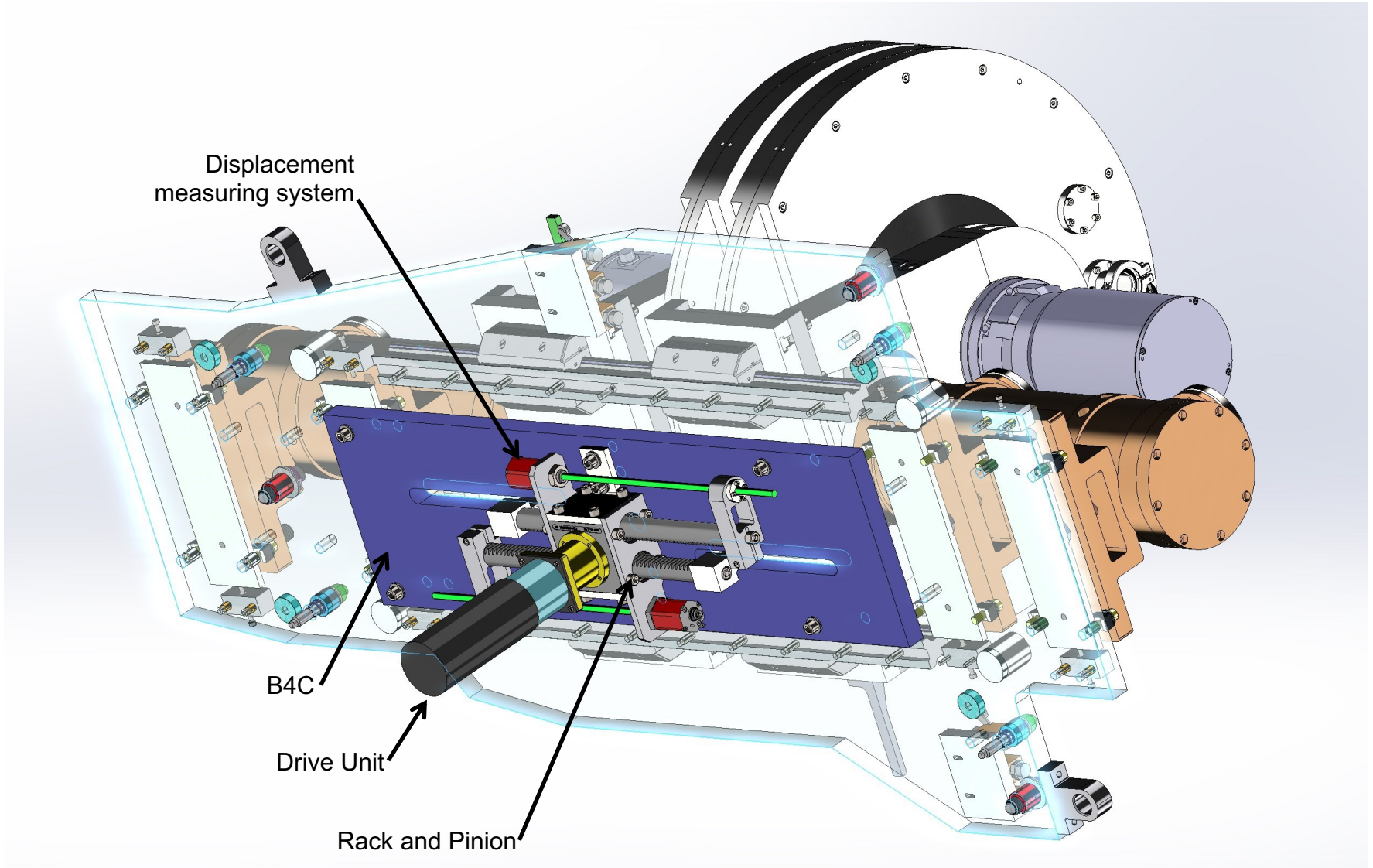


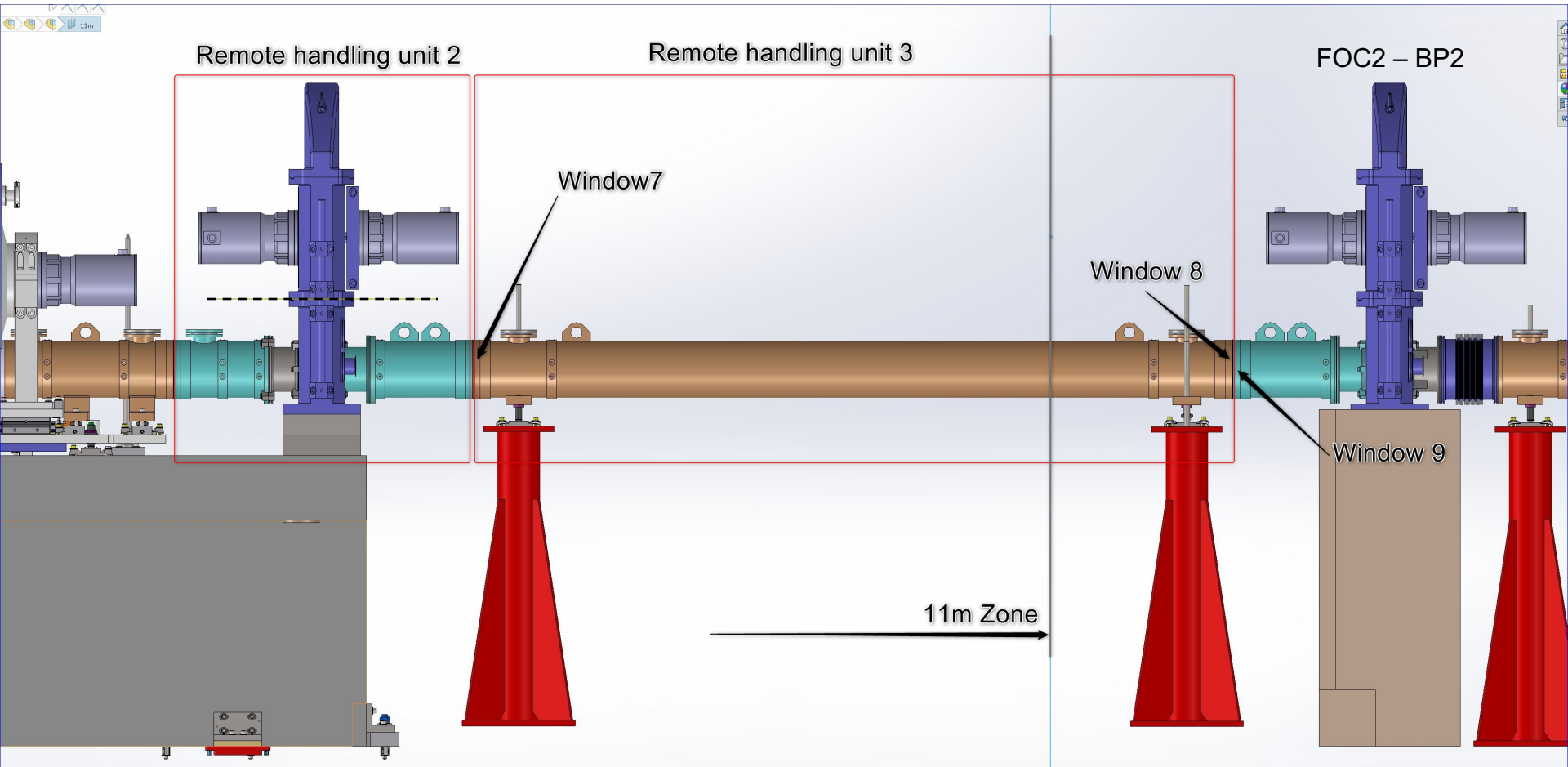


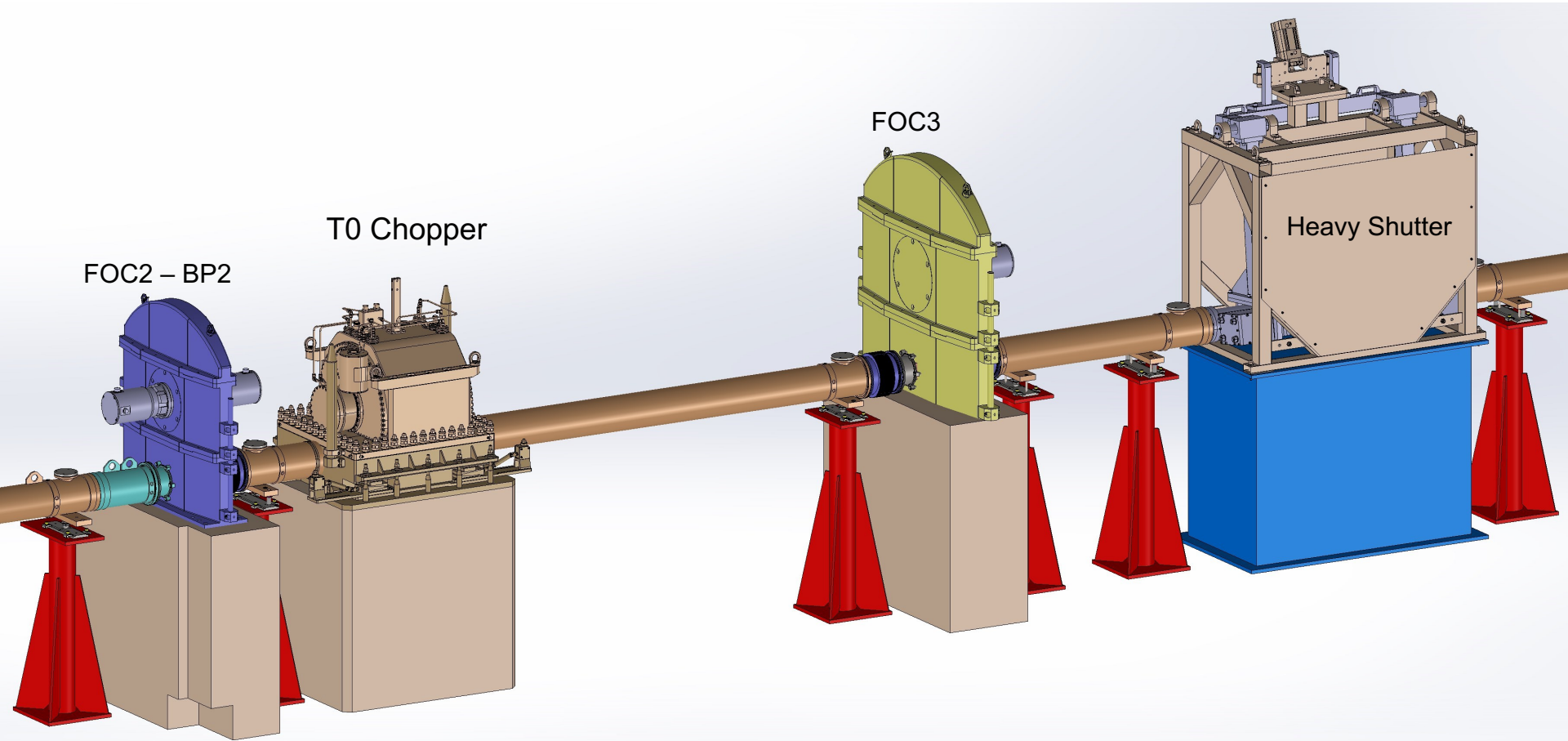




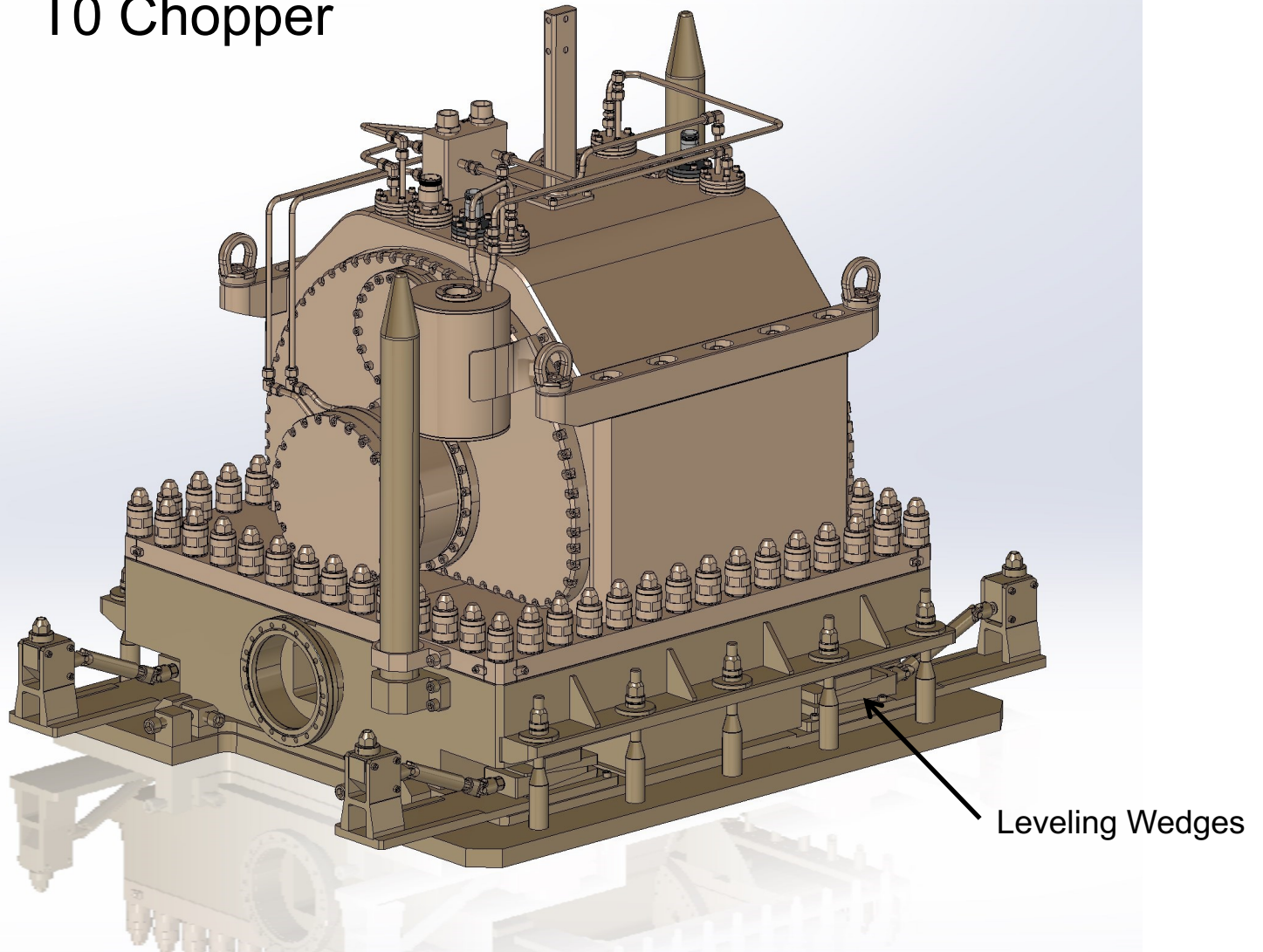








# T0 Chopper



Simulated Attenuation Materials:

10B4C: 3mm

Tungsten: 100mm

Copper : 30mm

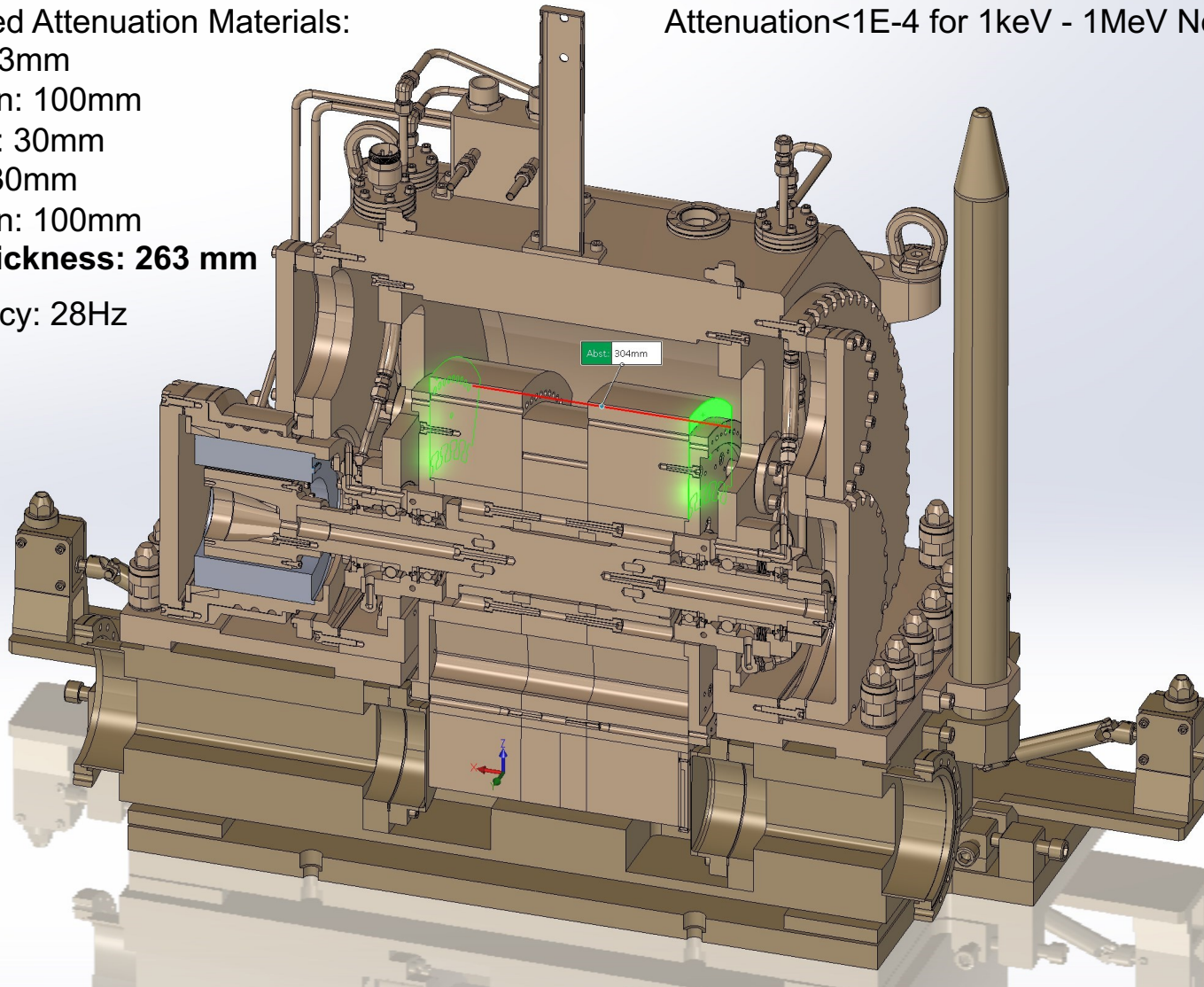
Nickel: 30mm

Tungsten: 100mm

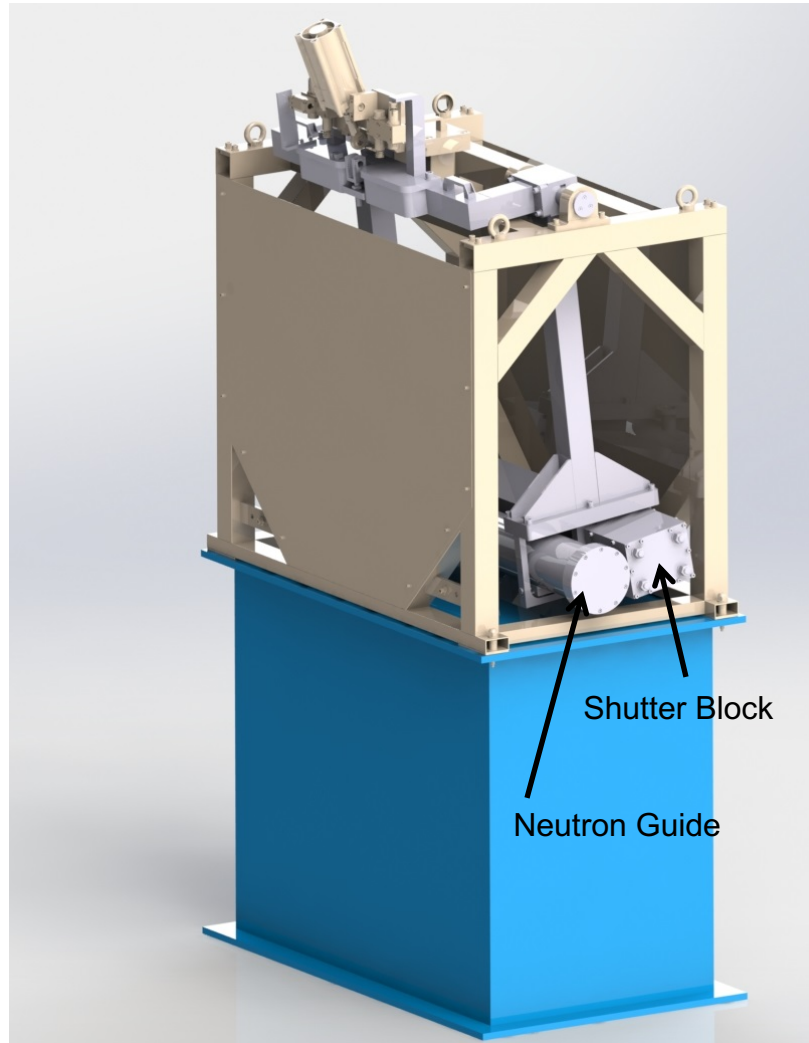
**Total thickness: 263 mm**

Frequency: 28Hz

Attenuation <math>< 1E-4</math> for 1keV - 1MeV Neutrons



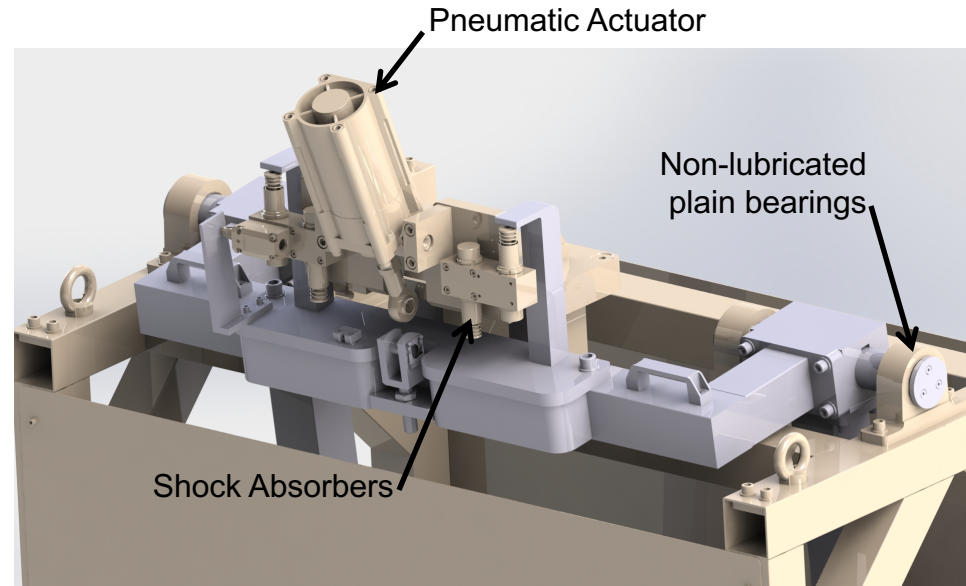
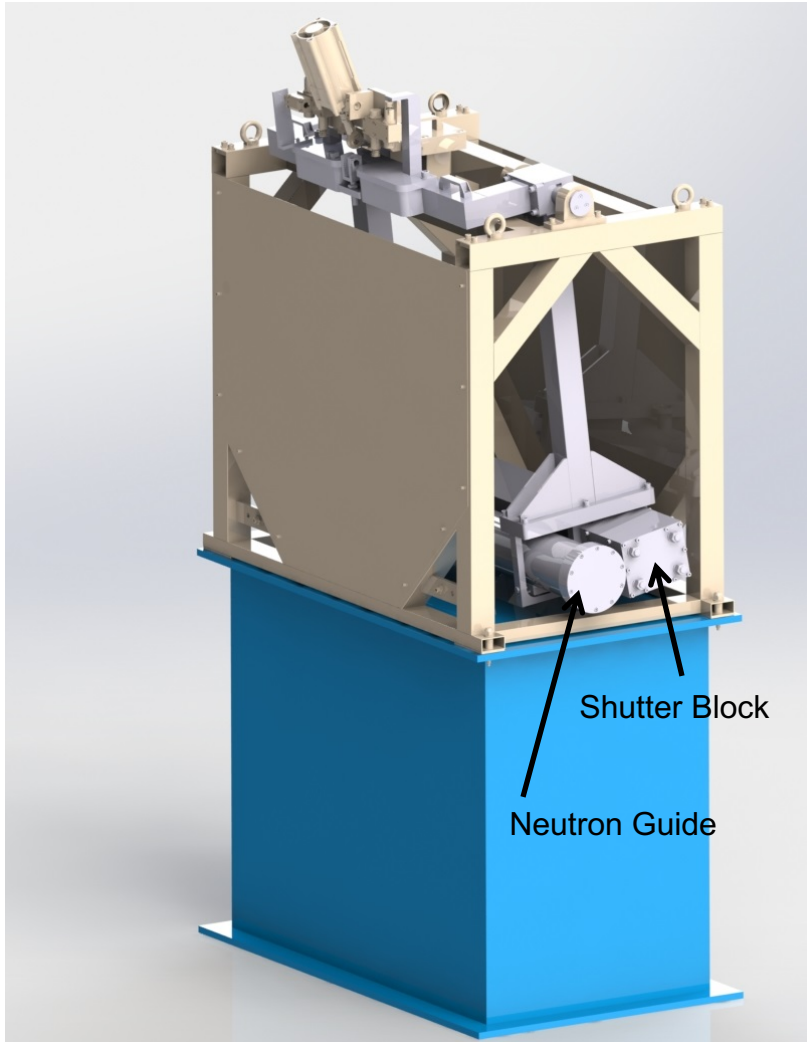
# Heavy Shutter



## Heavy Shutter requirements:

- The basic requirement is to have **3 $\mu$ Sv/h inside the cave and 25 $\mu$ Sv/h in the Chopper Pit for the FOC5**
- Design life >15yrs
- Service interval >5 years
- Reliability >98% (measured over 100 days of beam distribution)
- Construction materials shall be selected to achieve activation to levels compatible with access requirements (in the bunker), and instrument maintenance strategies. (i.e. levels comparable or lower than the activation of the current bunker rear wall).
- Material selection and construction compatible with facility requirements for decommissioning and disposal of activated equipment (i.e. level of activation, size of components compatible with disposal casks).
- Designed for 'hands on' serviceable within 30 days of beam off (full power) if service interval <15years.
- Serviceability in-situ strongly preferred.
- Installed mass <17t.
- Closing time after close command should be less than 2 minutes.

# Heavy Shutter



# Instrument design outside the Bunker

Cave:

## Radiation Requirements:

- Walls  $3\mu\text{Sv/h}$ . Roof  $25\mu\text{Sv/h}$
- Safety factor by ESS: 2
- Requires surface detectors of all walls and roof
- Operational Scenarios: Steel sample and water sample in experimental cave. Gd slice (2mm) (grating interferometer)
- Worst case scenarios: Cd (2mm) in optical or experimental cave

# Cave: MCNP Results: Version "L"

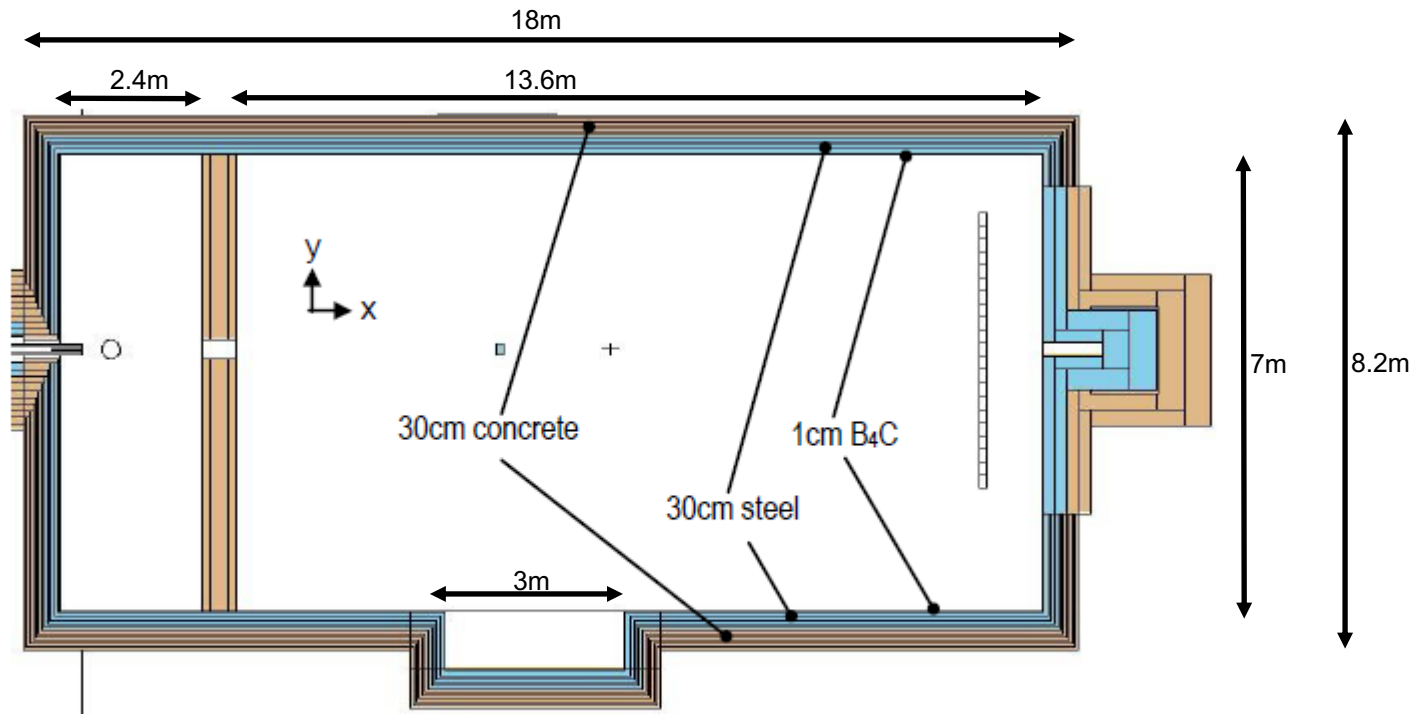


Fig. 126: Horizontal cut through the Monte Carlo model of the ODIN cave on the level of the beam axis

# Cave: MCNP Results

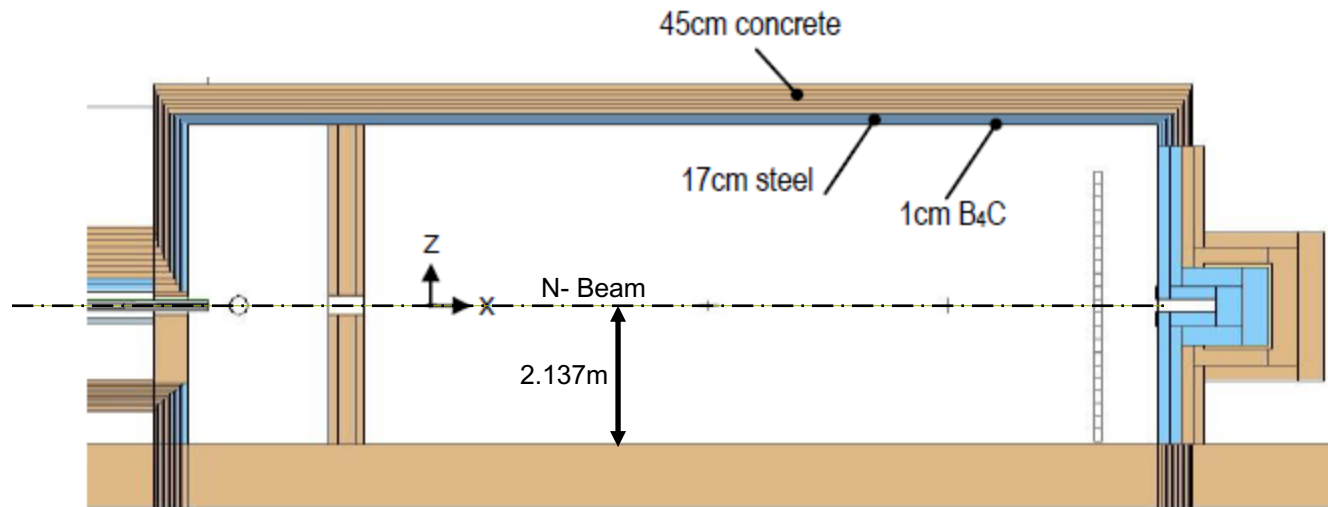
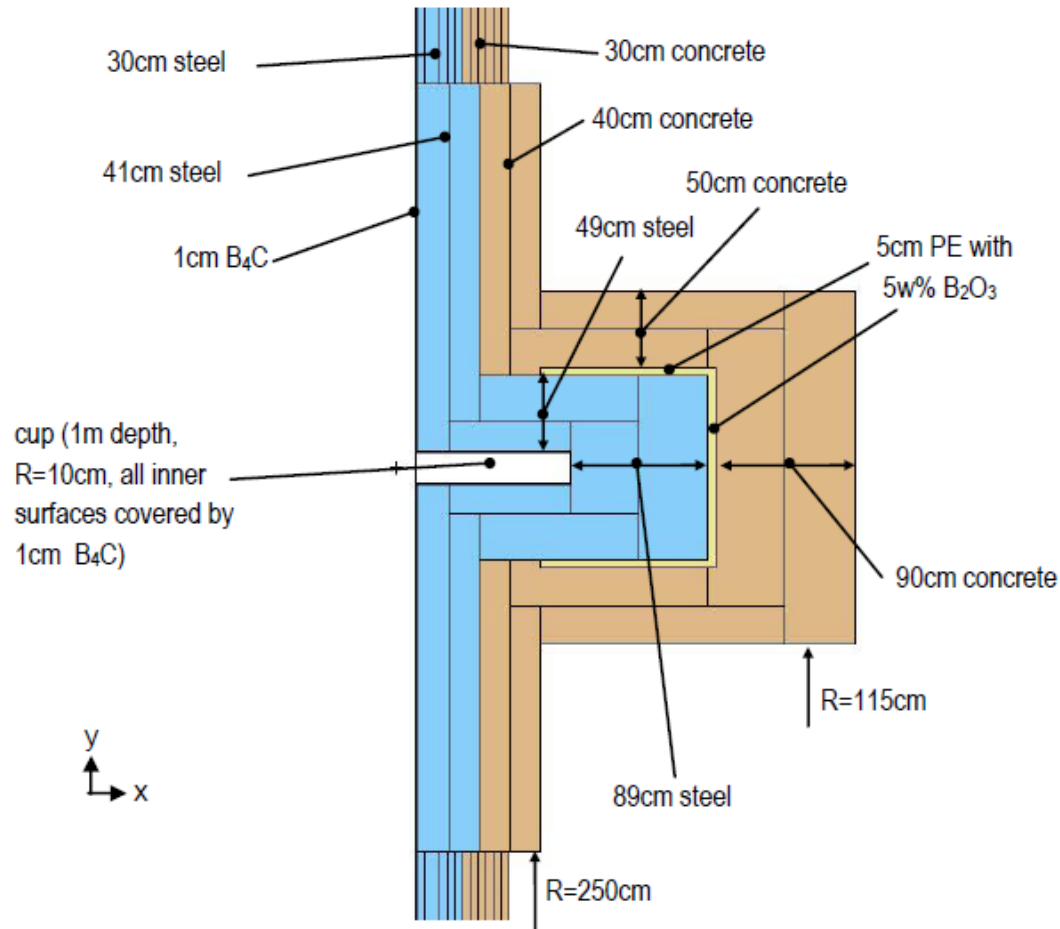


Fig. 127: Vertical cut through the Monte Carlo model of the ODIN cave along the beam axis

# Cave: MCNP Results



# Cave: MCNP Results

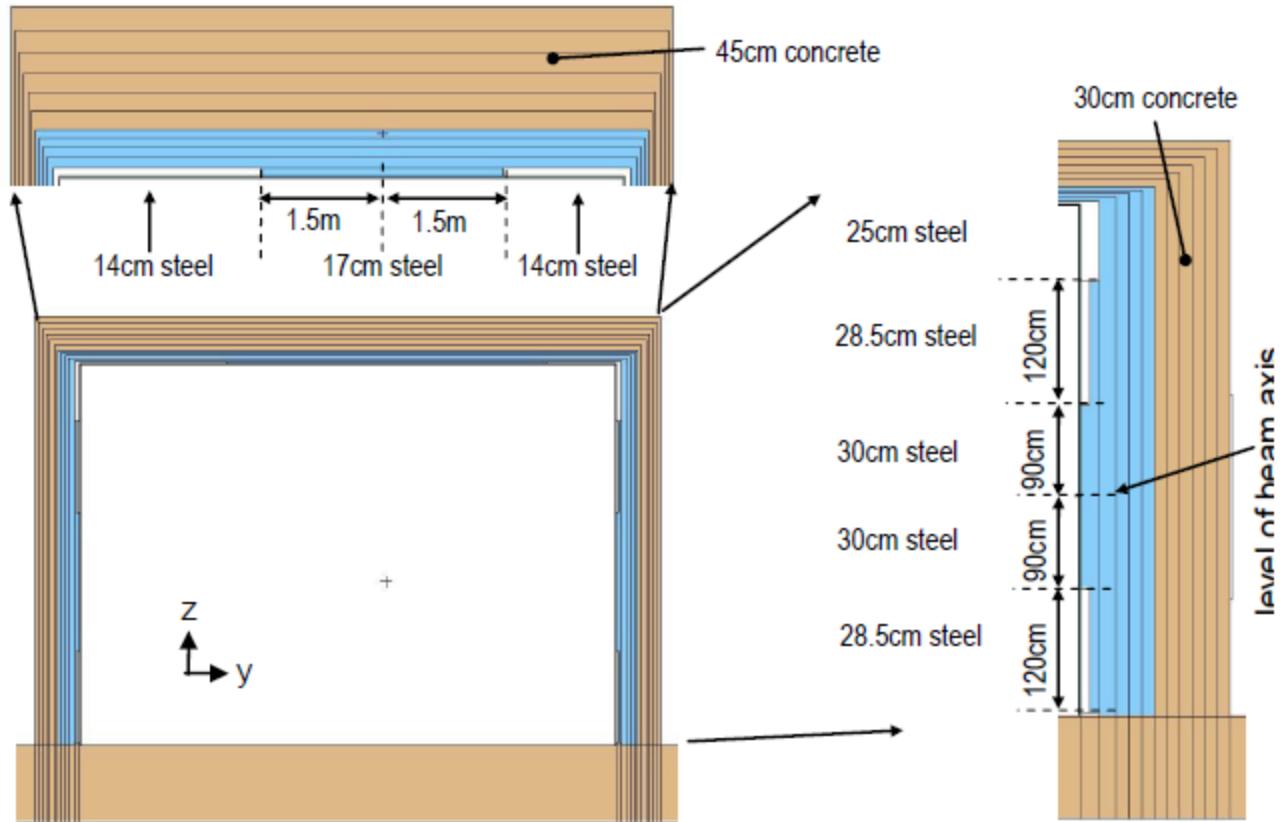


Fig. 128: Vertical cut through the Monte Carlo model of the ODIN cave perpendicular to the beam axis

# Cave: MCNP Results

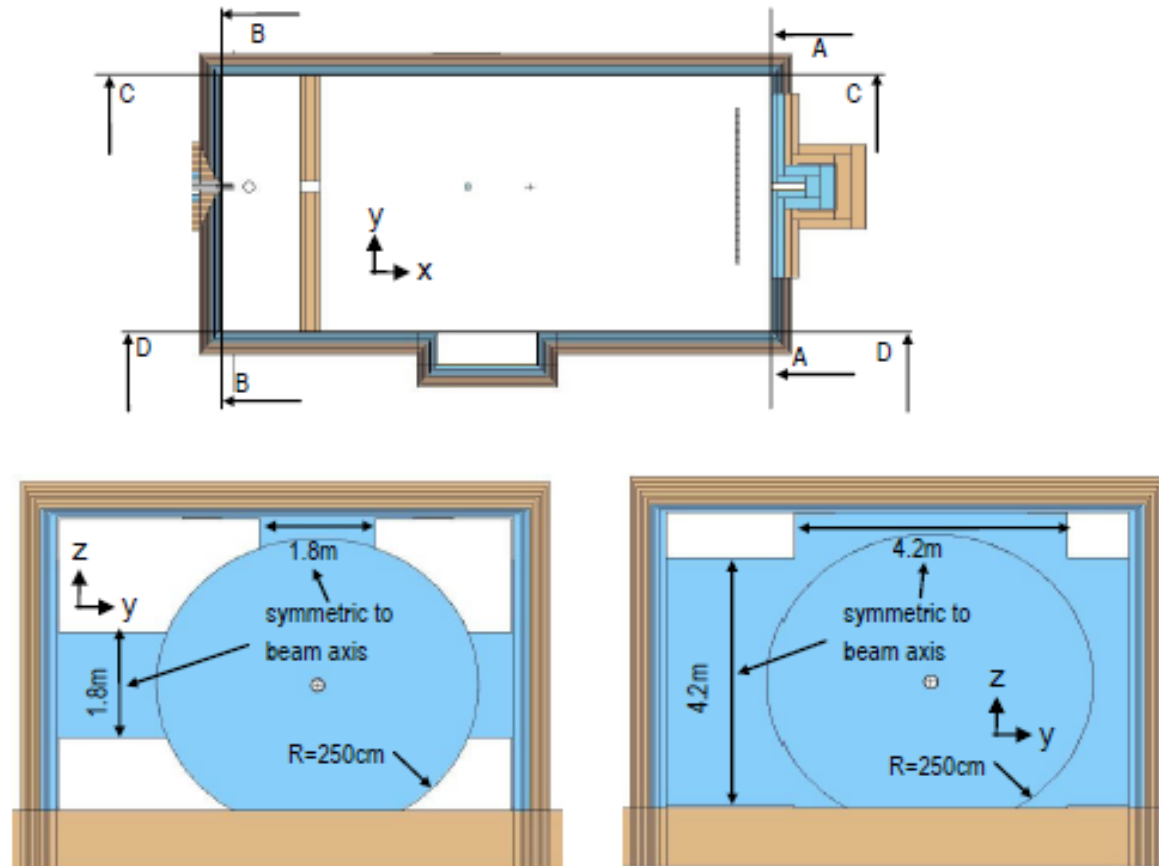
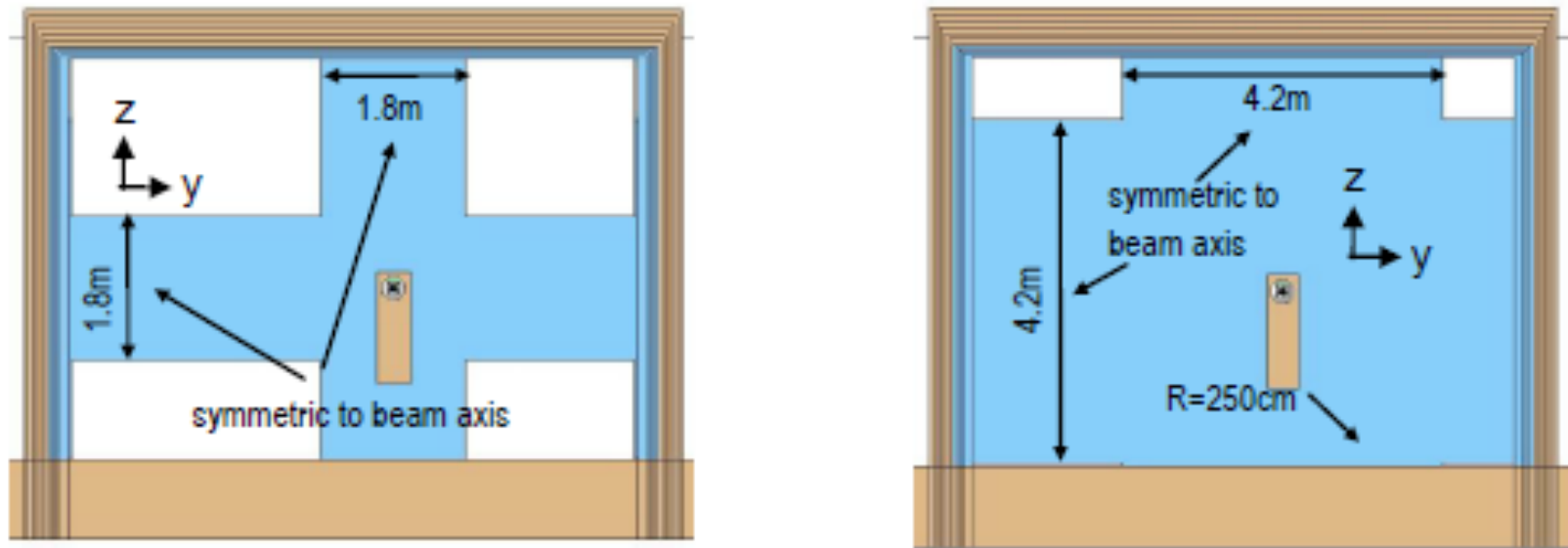


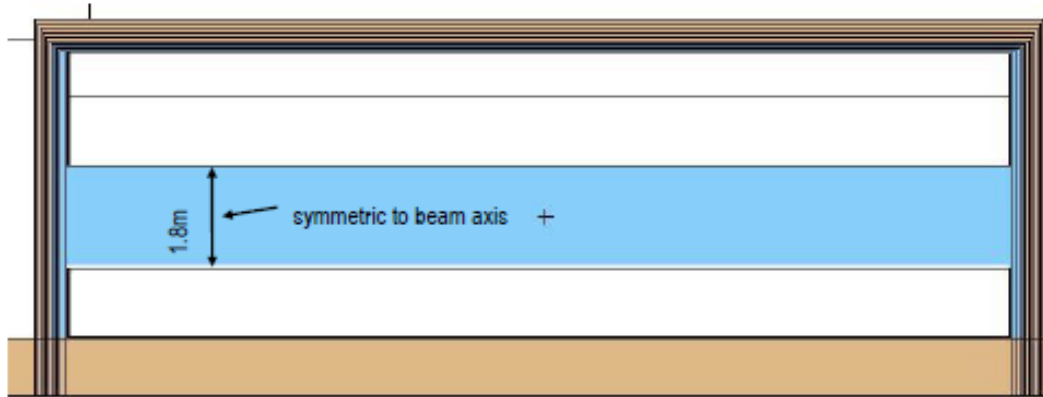
Fig. 129 Left hand side: Vertical cut through the Monte Carlo model of the ODIN cave perpendicular to the beam axis through step 1 of the steel layer (30cm thick layer) at the rear wall, cut A-A). Right hand side: Vertical cut through the Monte Carlo model of the ODIN cave perpendicular to the beam axis through step 2 of the steel layer (28,5cm thick layer) at the rear wall, cut A-A)

# Cave: MCNP Results

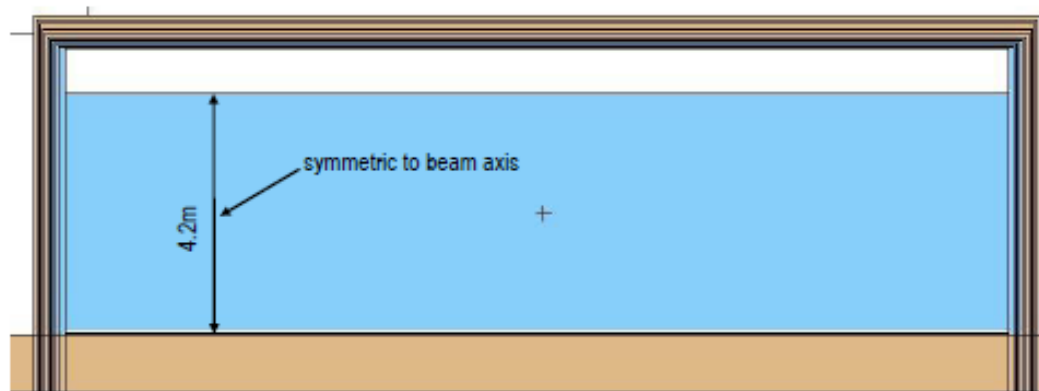


*Fig. 130 Left hand side: Vertical cut through the Monte Carlo model of the ODIN cave perpendicular to the beam axis through step 1 of the steel layer (30cm thick layer) at the front wall, cut B-B). Right hand side: Vertical cut through the Monte Carlo model of the ODIN cave perpendicular to the beam axis through step 2 of the steel layer (28,5cm thick layer) at the front wall, cut B-B)*

## Cave: MCNP Results

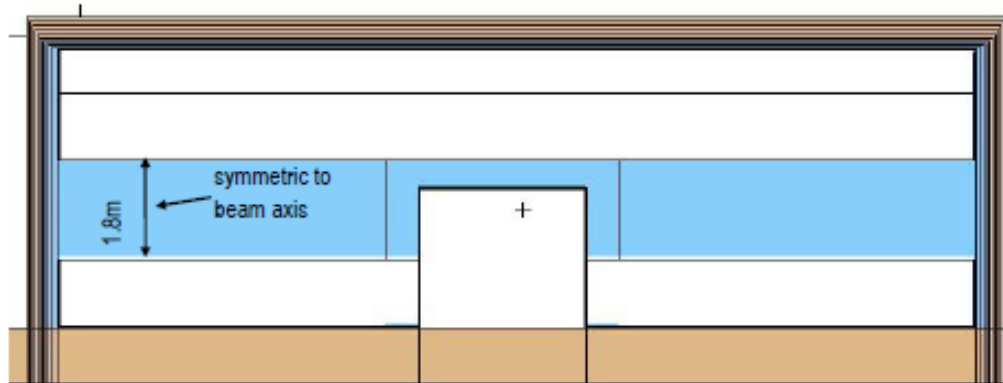


*Fig. 131 Vertical cut through the Monte Carlo model of the ODIN cave parallel to the beam axis through step 1 of the steel layer (30cm thick layer) at the left wall, cut C-C).*

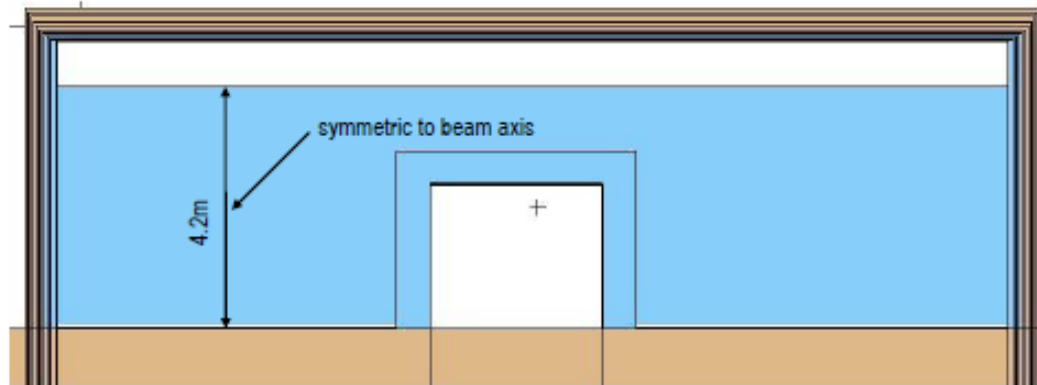


*Fig. 132: Vertical cut through the Monte Carlo model of the ODIN cave parallel to the beam axis through step 2 of the steel layer (28,5cm thick layer) at the left wall, cut C-C)*

## Cave: MCNP Results

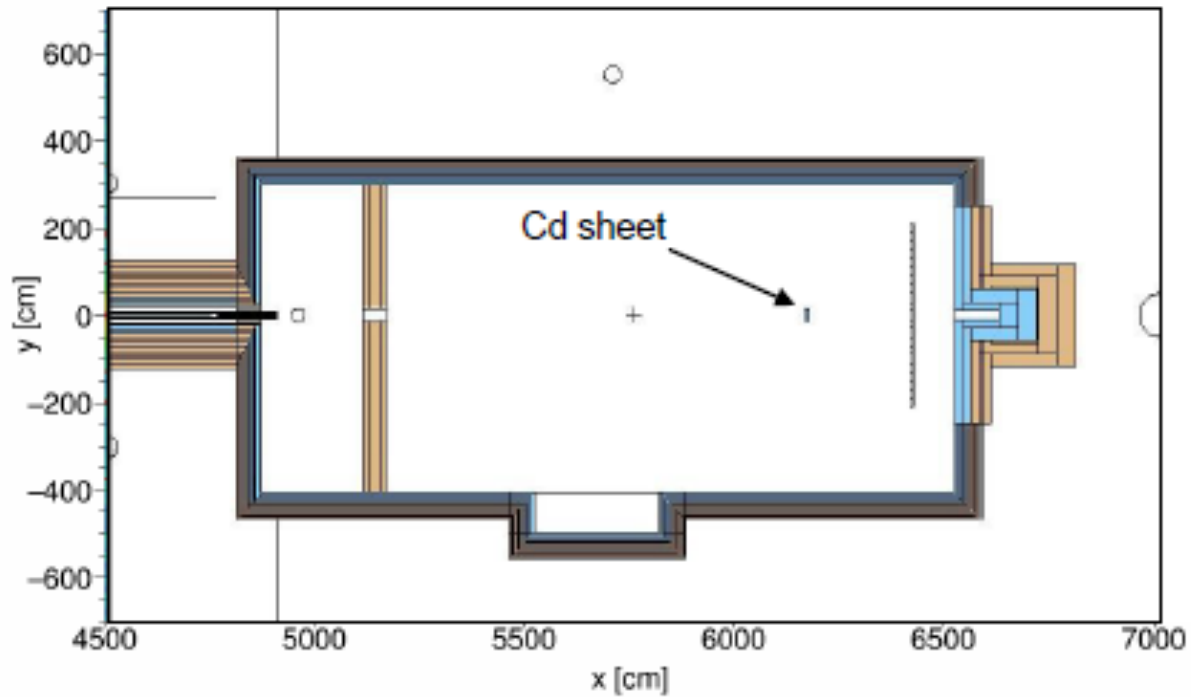


*Fig. 133 Vertical cut through the Monte Carlo model of the ODIN cave parallel to the beam axis through step 1 of the steel layer (30cm thick layer) at the right wall, cut D-D).*



*Fig. 134: Vertical cut through the Monte Carlo model of the ODIN cave parallel to the beam axis through step 2 of the steel layer (28,5cm thick layer) at the right wall, cut D-D)*

# Cave: MCNP Results



*Fig. 135: Horizontal area through the Monte Carlo model of the cave of the ODIN instrument on the level of the beam axis for which the radiation distributions are shown in the following images*

# Cave: MCNP Results

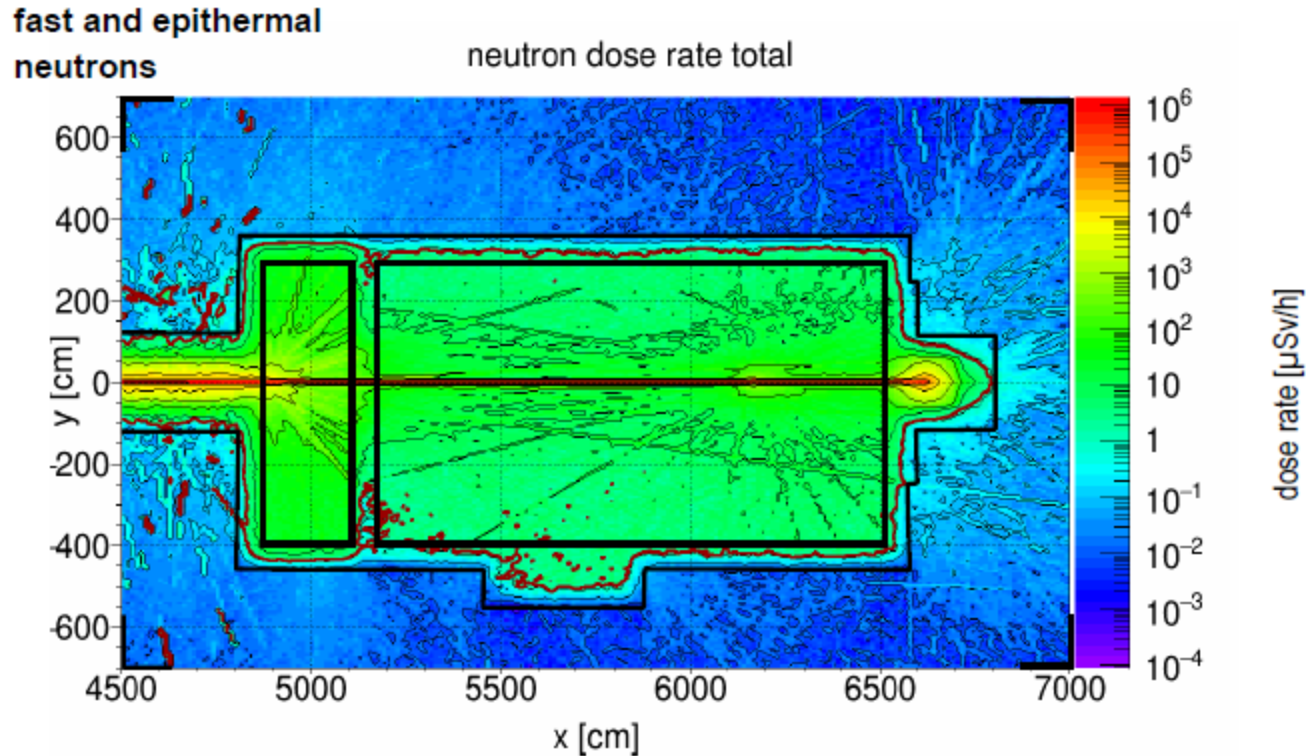


Fig. 136: Neutron dose rate without consideration of total reflection (fast and epithermal neutrons; thermal neutron flux underestimated). The red line is the 1.5μSv/h border. The maximum of the scale is the maximum that appears in the diagram.

# Cave: MCNP Results

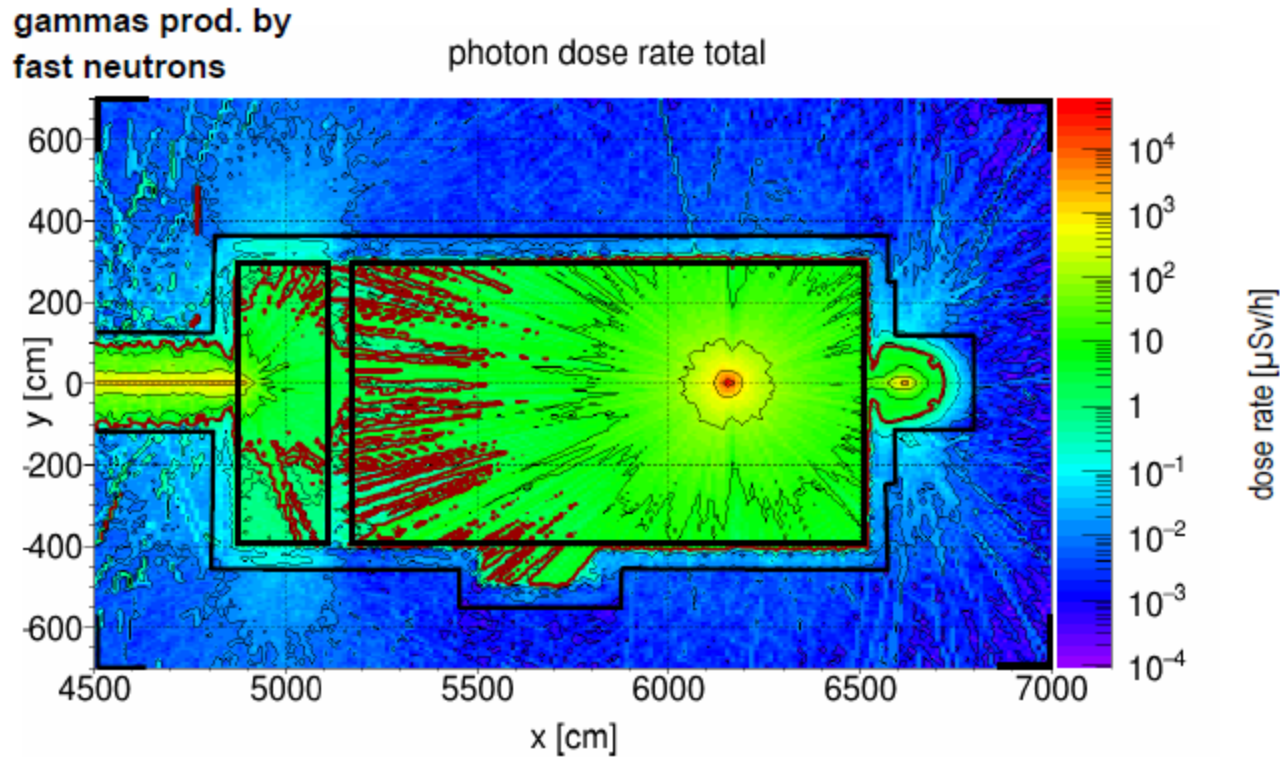


Fig. 137: Gamma dose rate produced by fast and epithermal neutrons without consideration of neutron total reflection. The red line is the 1.5μSv/h border. The maximum of the scale is the maximum that appears in the diagram.

# Cave: MCNP Results

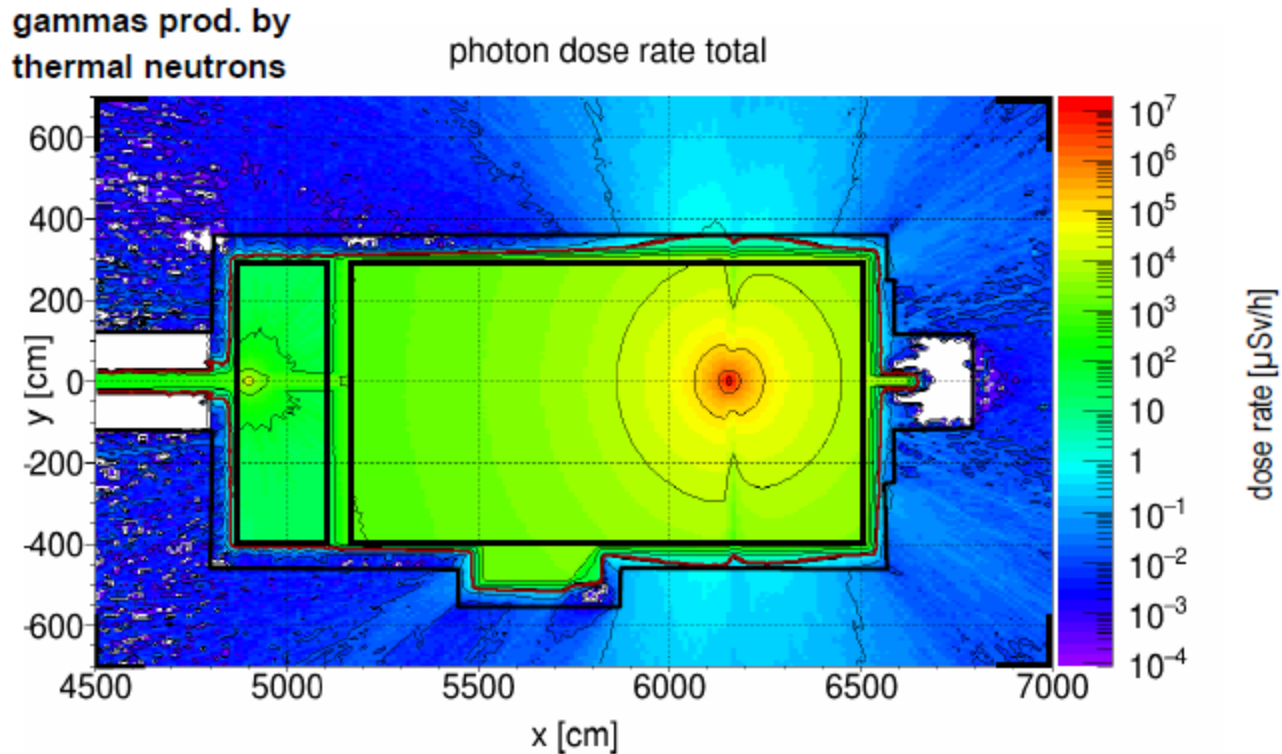
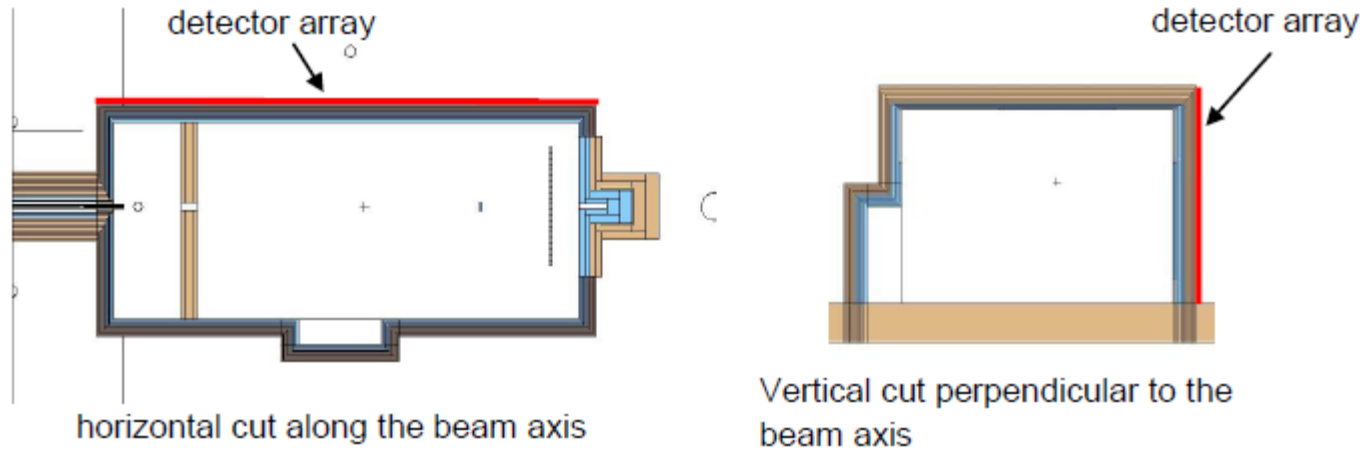


Fig. 138: Gamma dose rate produced by thermal neutrons under consideration of neutron total reflection. The red line is the  $1.5\mu\text{Sv/h}$  border. The maximum of the scale is the maximum that appears in the diagram.

# Cave: MCNP Results

## 9.4 Dose rate distribution on the left outer surface of the cave



# Cave: MCNP Results

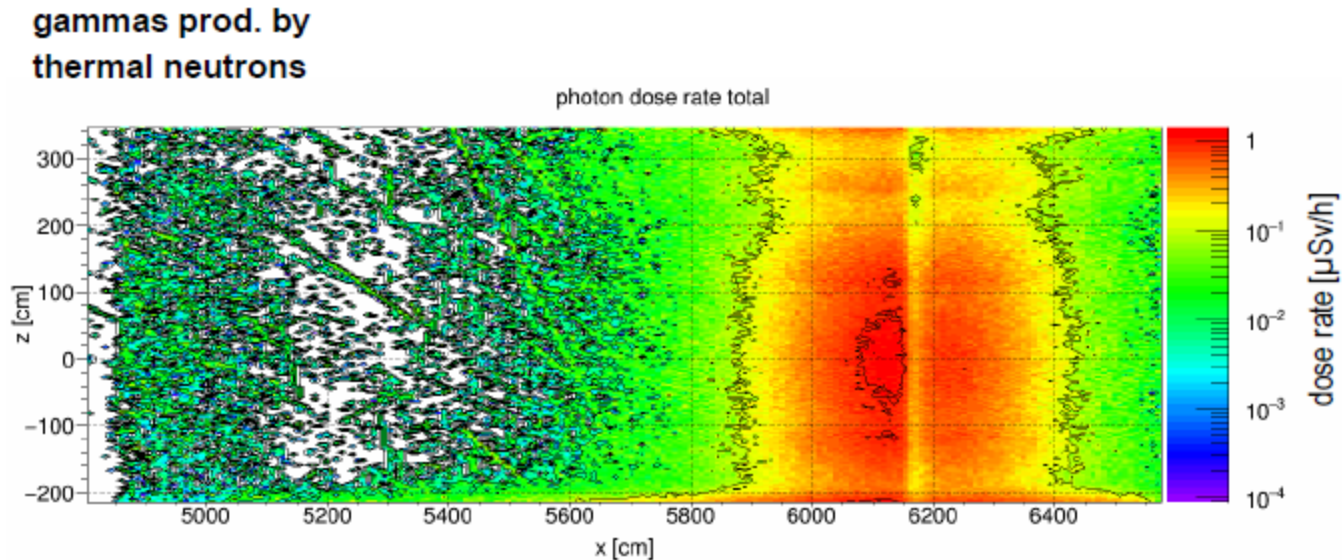


Fig. 142: Gamma dose rate produced by thermal neutrons under consideration of neutron total reflection. The red line is the  $1.5\mu\text{Sv/h}$  border. The maximum of the scale is the maximum that appears in the diagram.

The desired dose rate level of  $1.5\mu\text{Sv/h}$  is not exceeded.

# Cave: MCNP Results

## 9.8 Dose rate distribution on the top outer surface of the cave

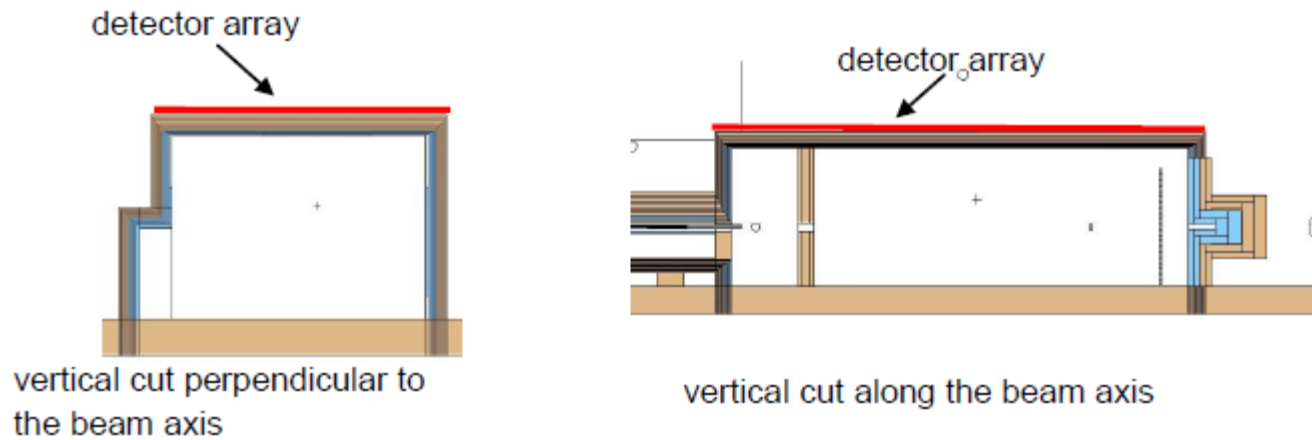


Fig. 155: Location of the detector array

# Cave: MCNP Results

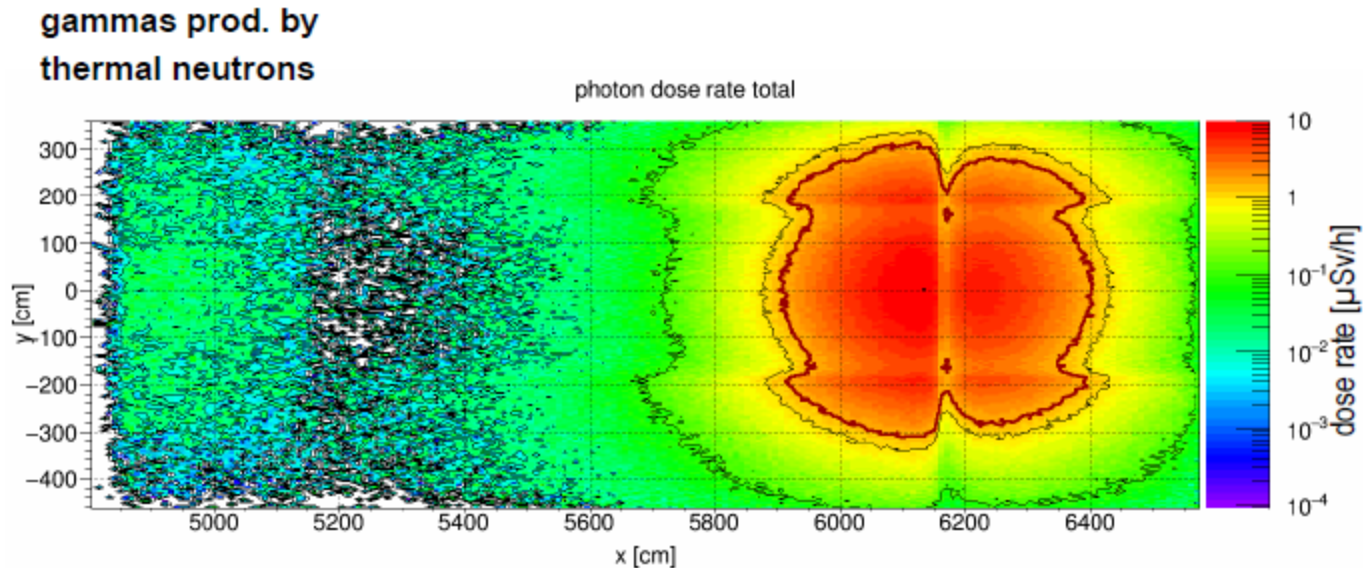


Fig. 158: Gamma dose rate produced by thermal neutrons under consideration of neutron total reflection. The red line is the  $1.5\mu\text{Sv/h}$  border. The maximum of the scale is the maximum that appears in the diagram.

The desired dose rate level of  $12.5\mu\text{Sv/h}$  on the roof is not exceeded.

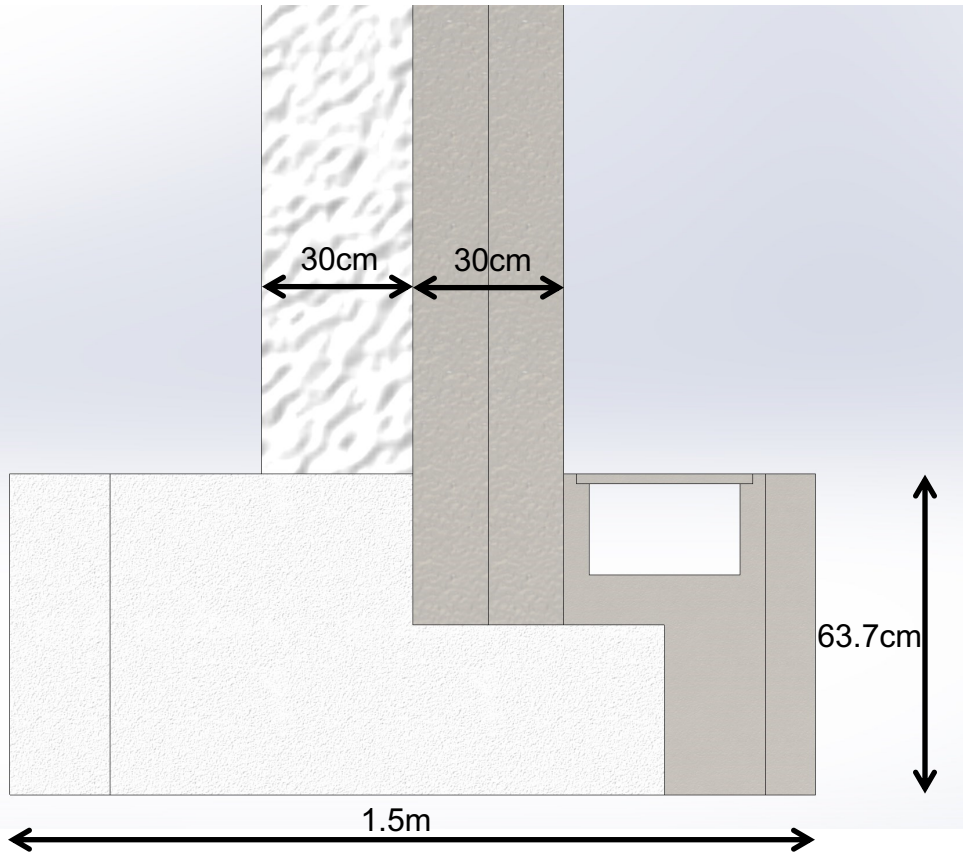
Cave - MCNP Conclusion:  
With version “L” of the ODIN cave the desired  
dose rate levels are not exceeded.

# Instrument design outside the Bunker

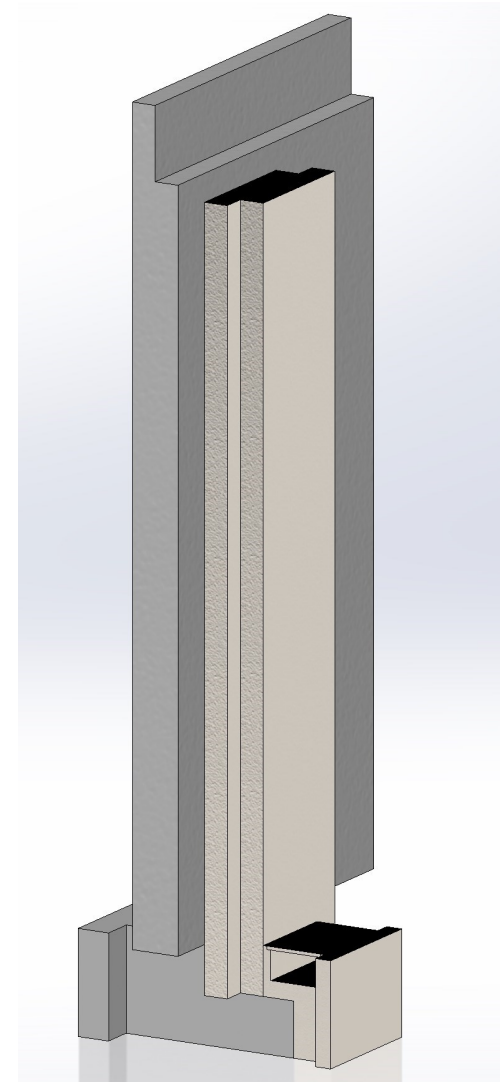
## Cave: Technical Design

# Cave: Technical Design

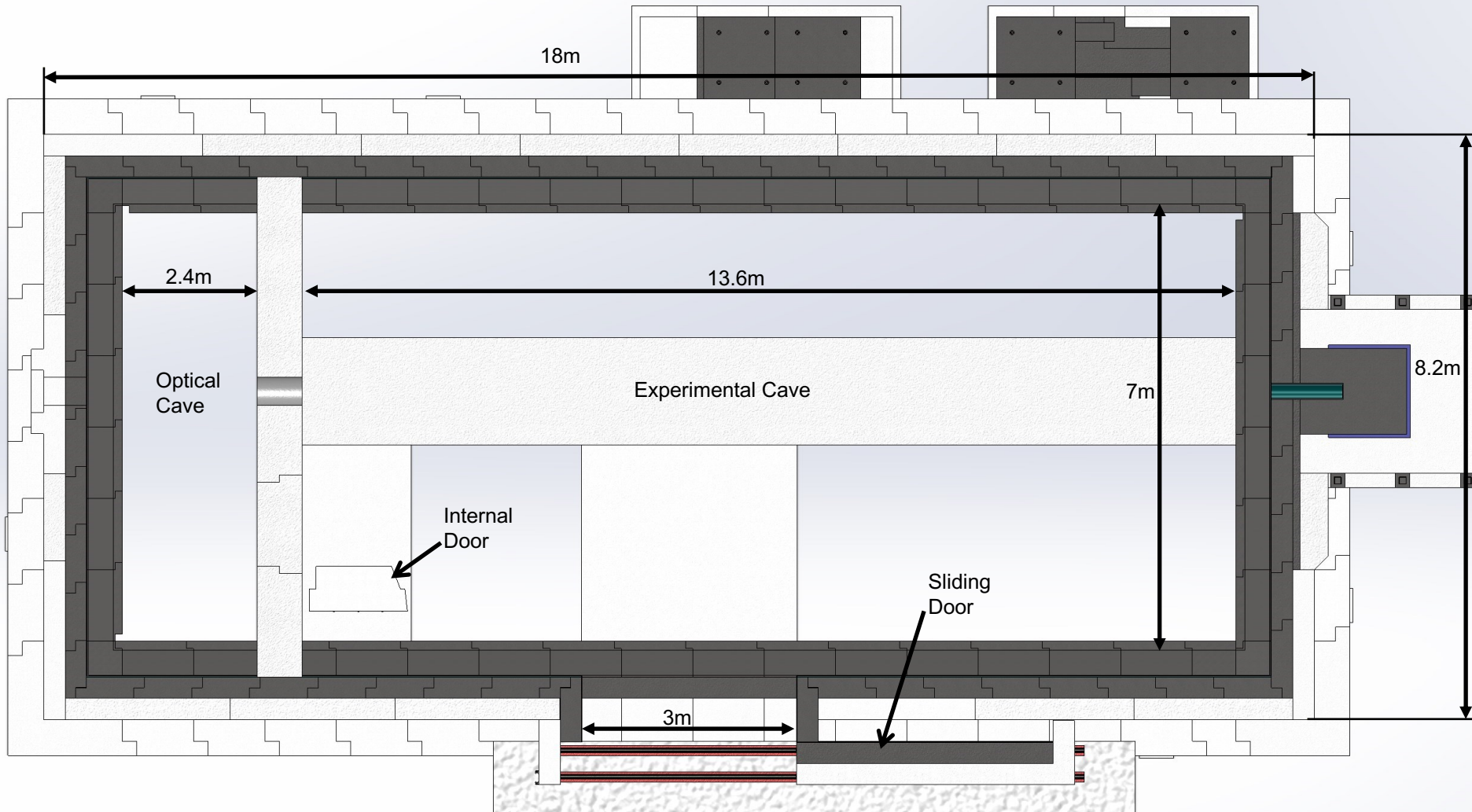
Floor load <math>< 14\text{t/m}^2</math>



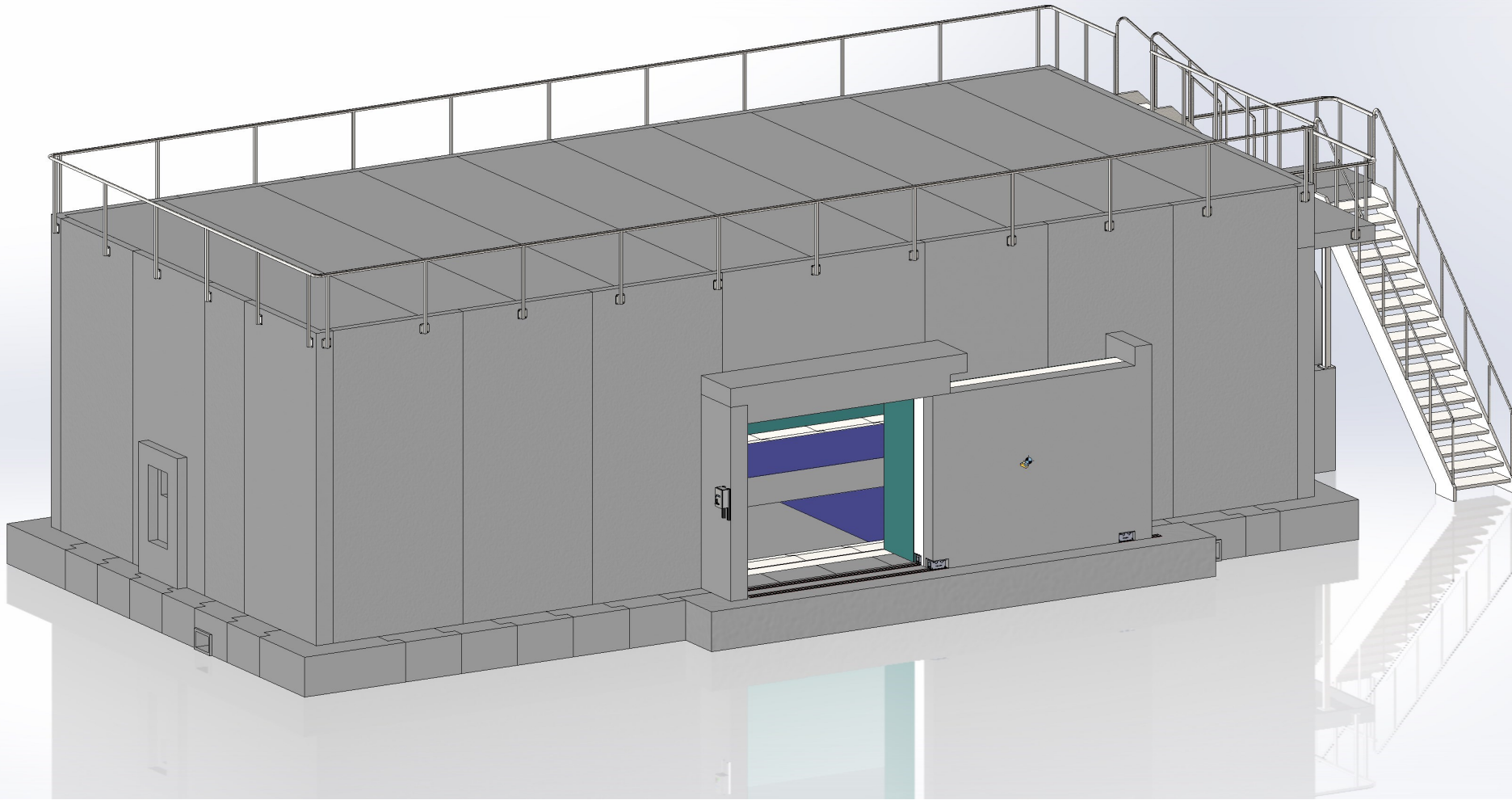
Design of a possible option on the bases to transmit the load from the walls and roof to the floor keeping the load on the floor within the required limits



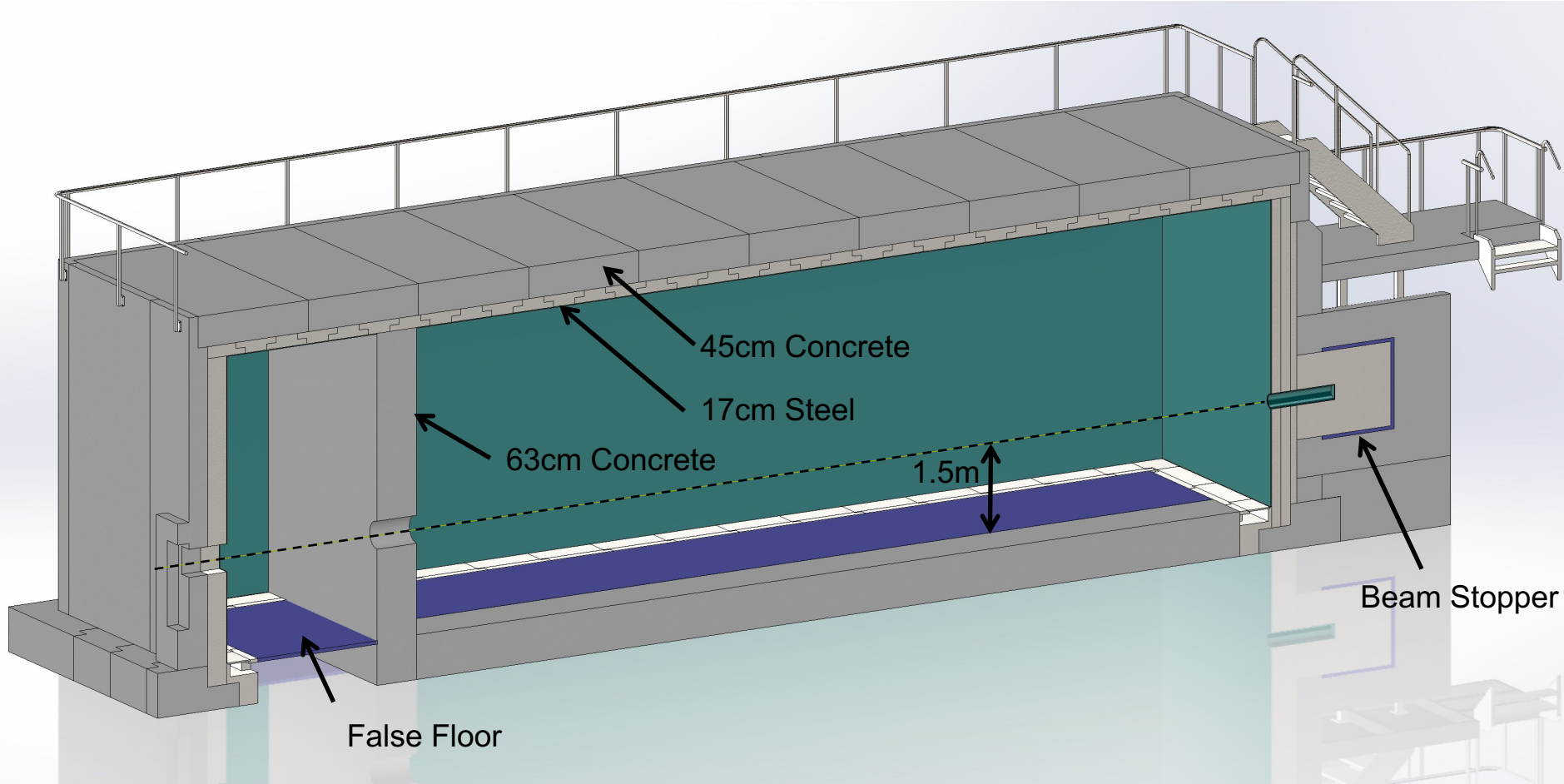
# Cave: Technical Design



# Cave: Technical Design

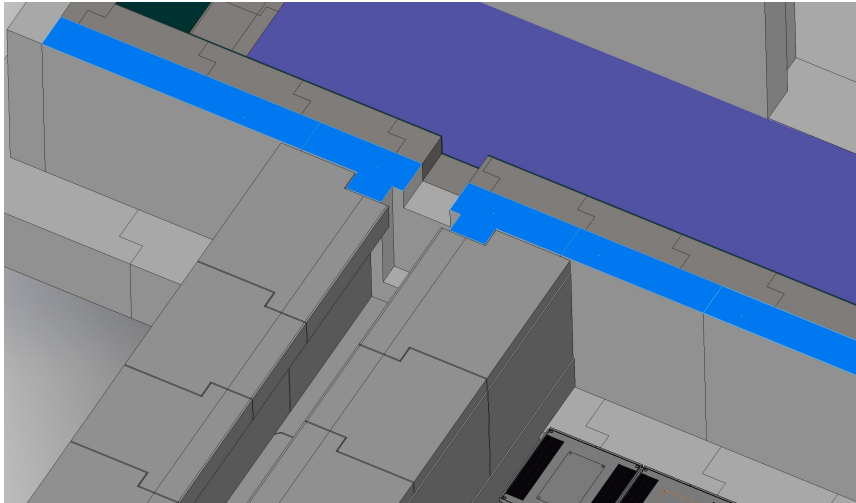


# Cave: Technical Design

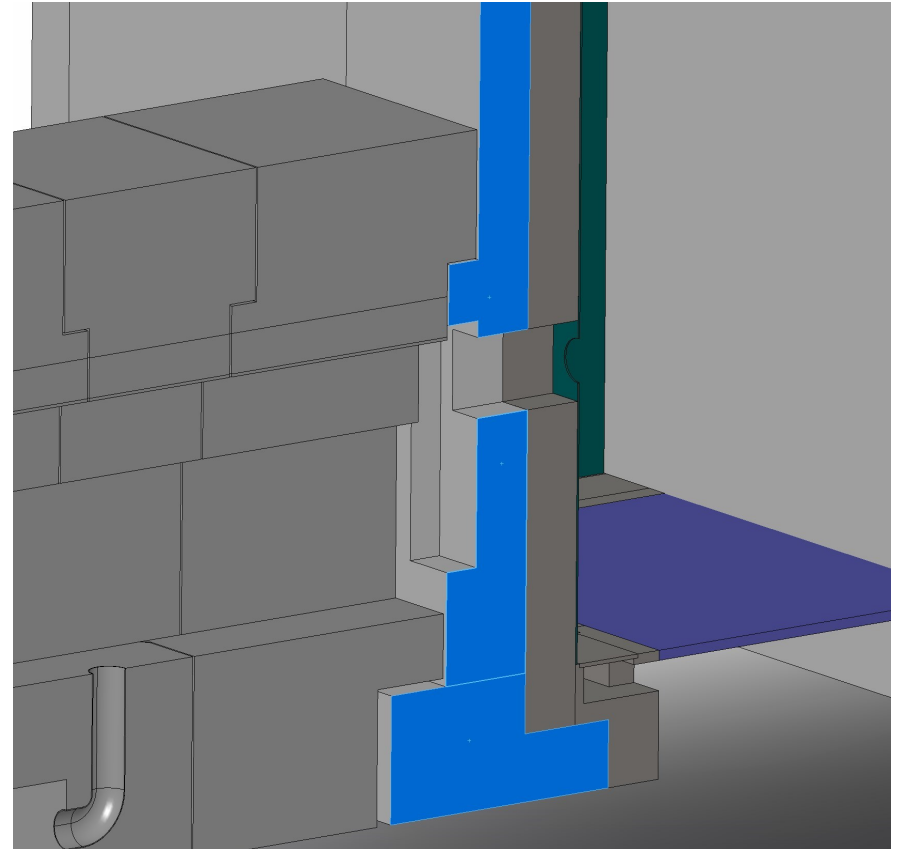


# Cave: Technical Design

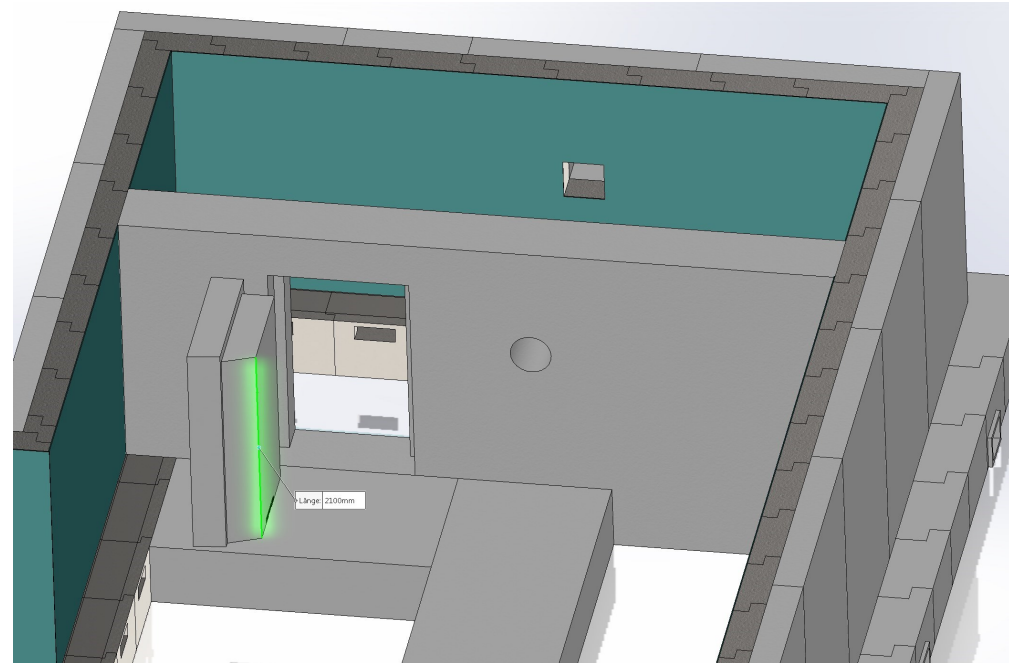
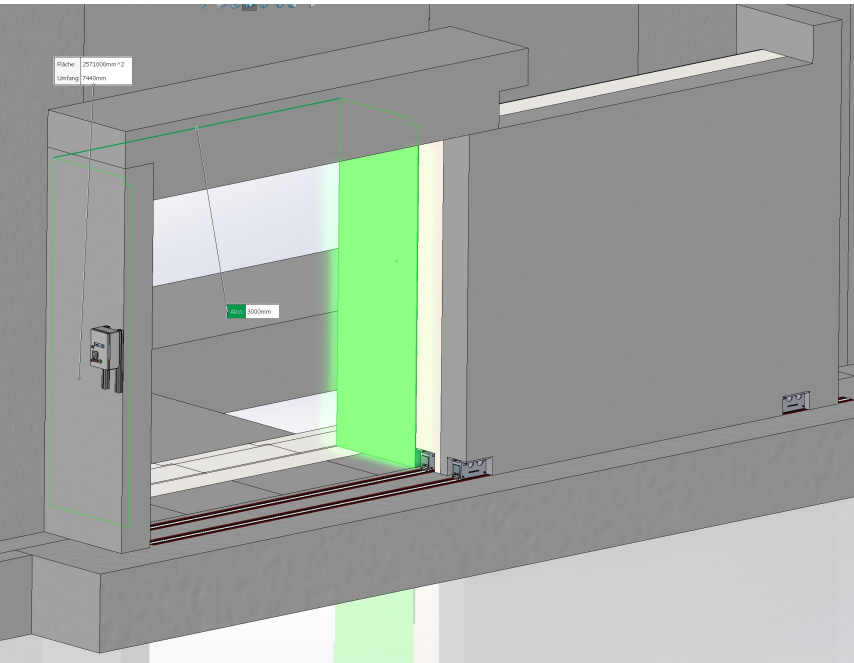
Interface Guide Shielding – Cave  
Horizontal Cut



Interface Guide Shielding – Cave  
Vertical Cut

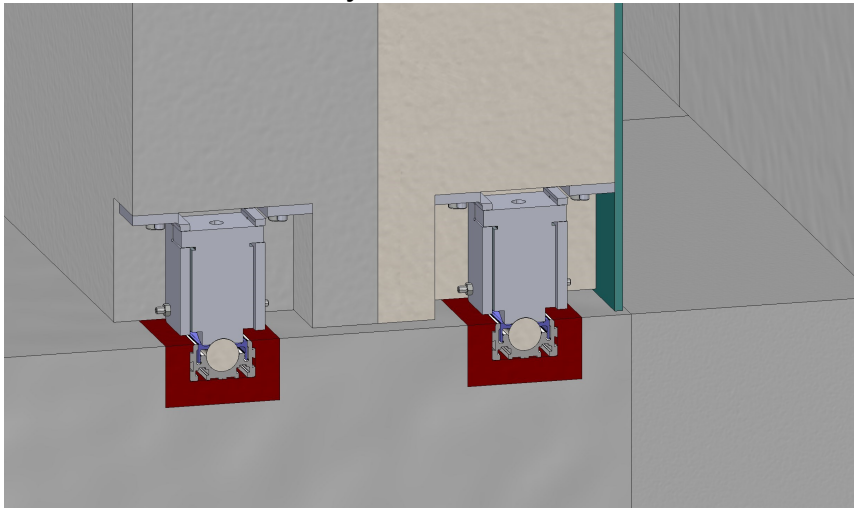


# Cave: Technical Design

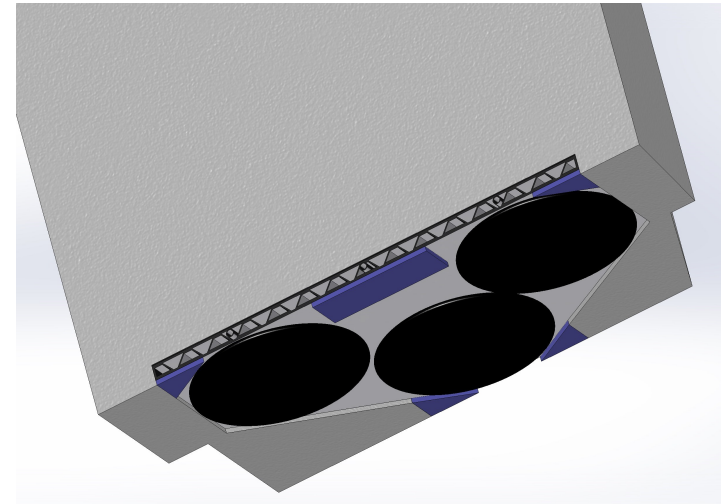


## Cave: Technical Design

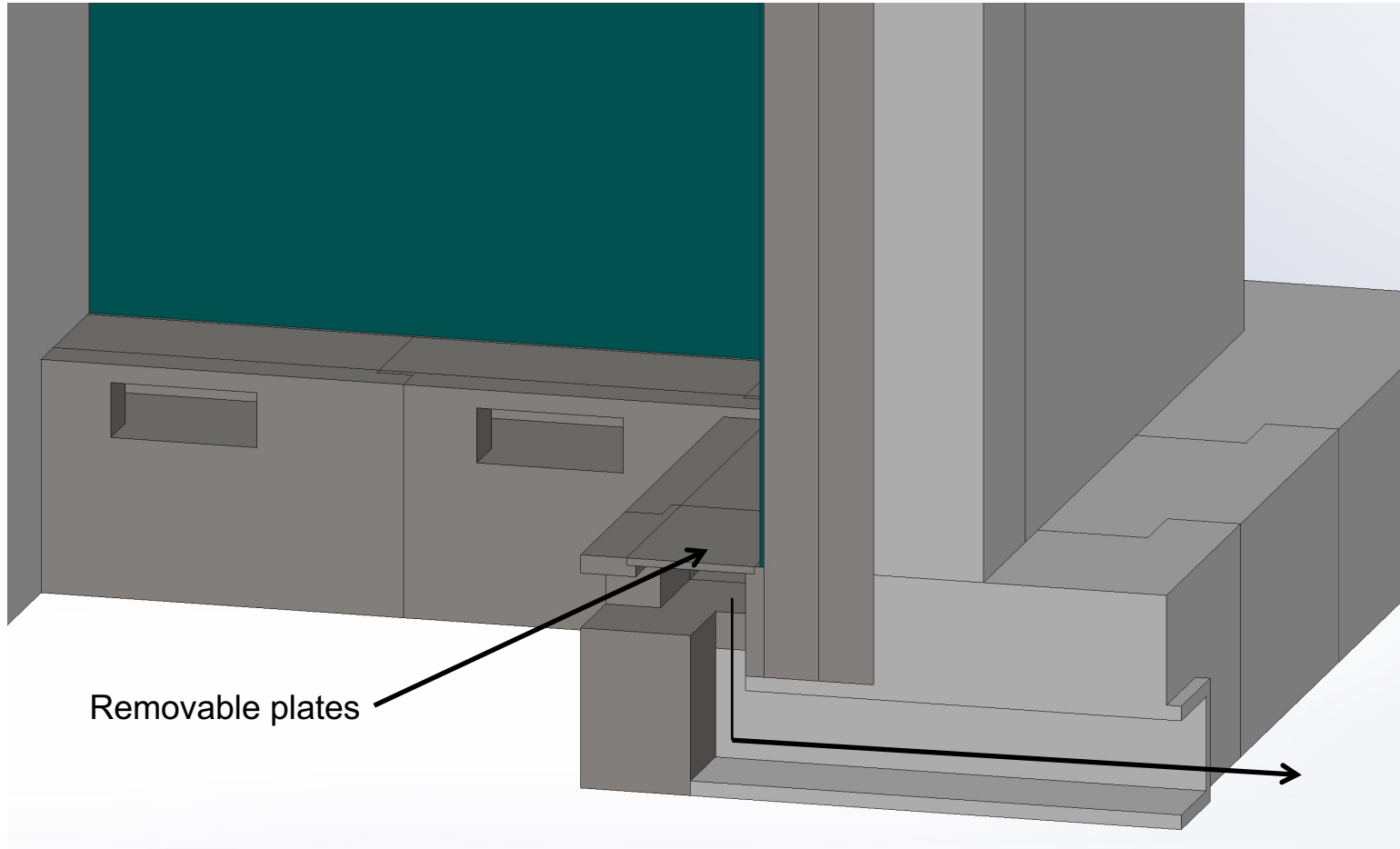
Sliding Door:  
Round track system



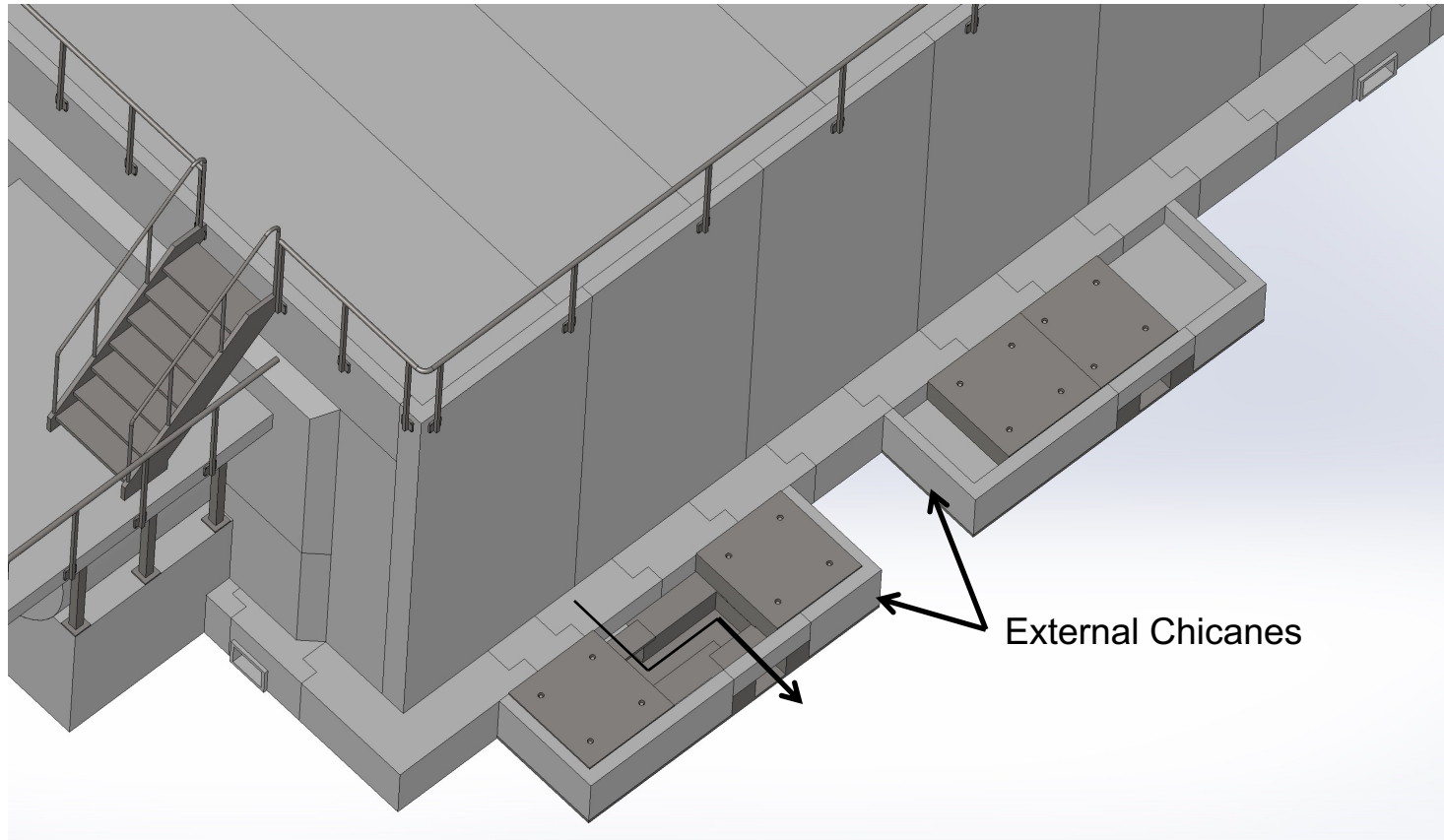
Internal Door:  
Air cushion modules



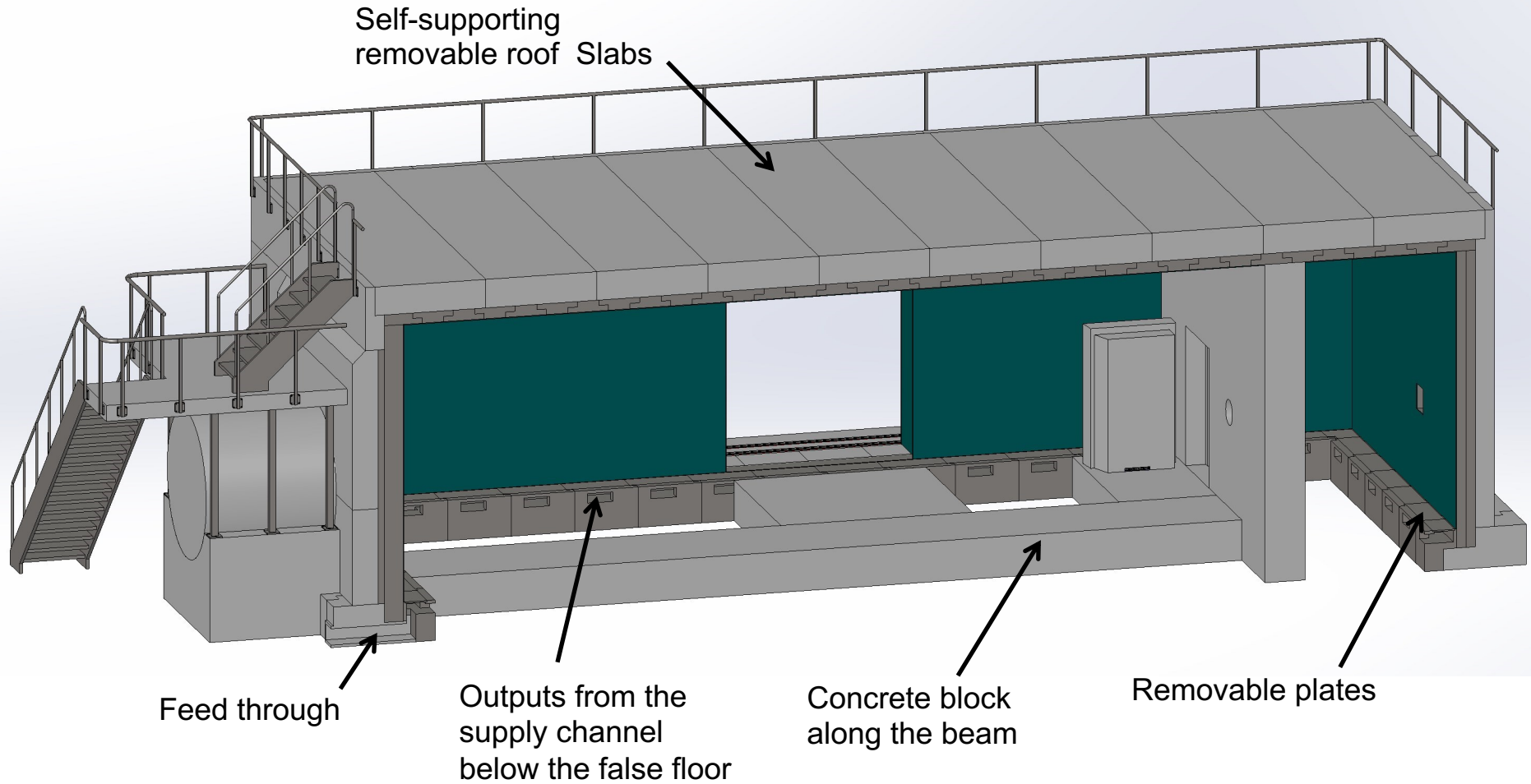
# Cave: Technical Design



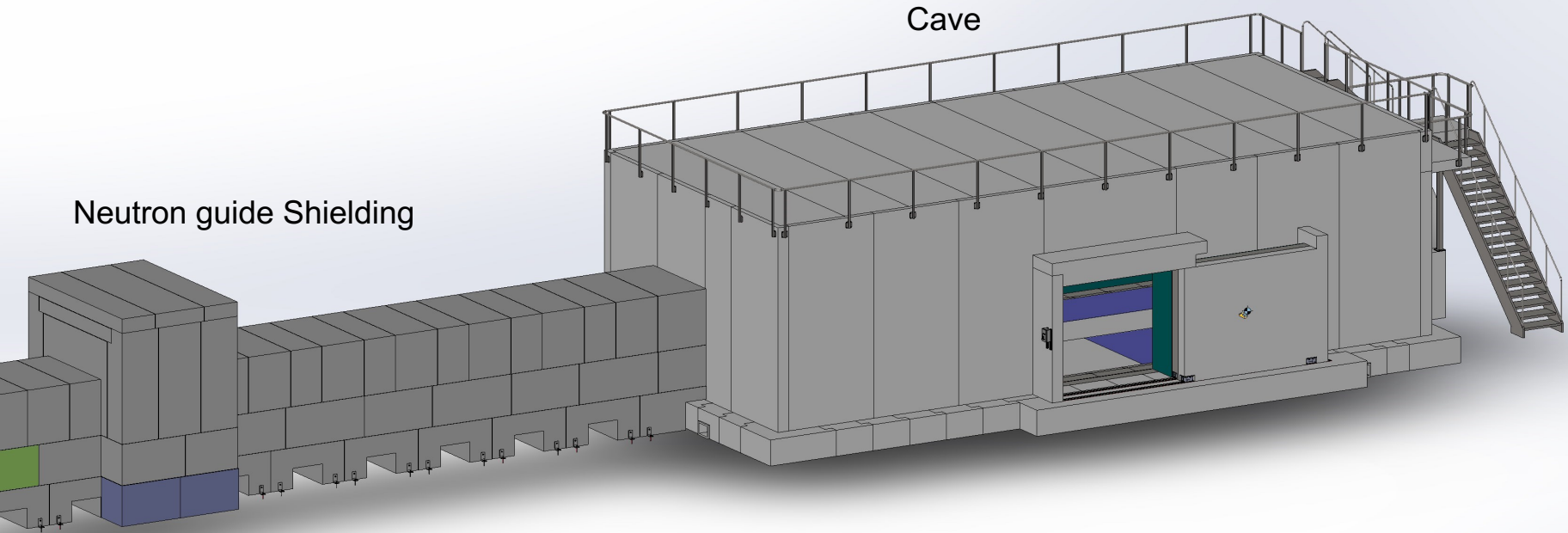
## Cave: Technical Design



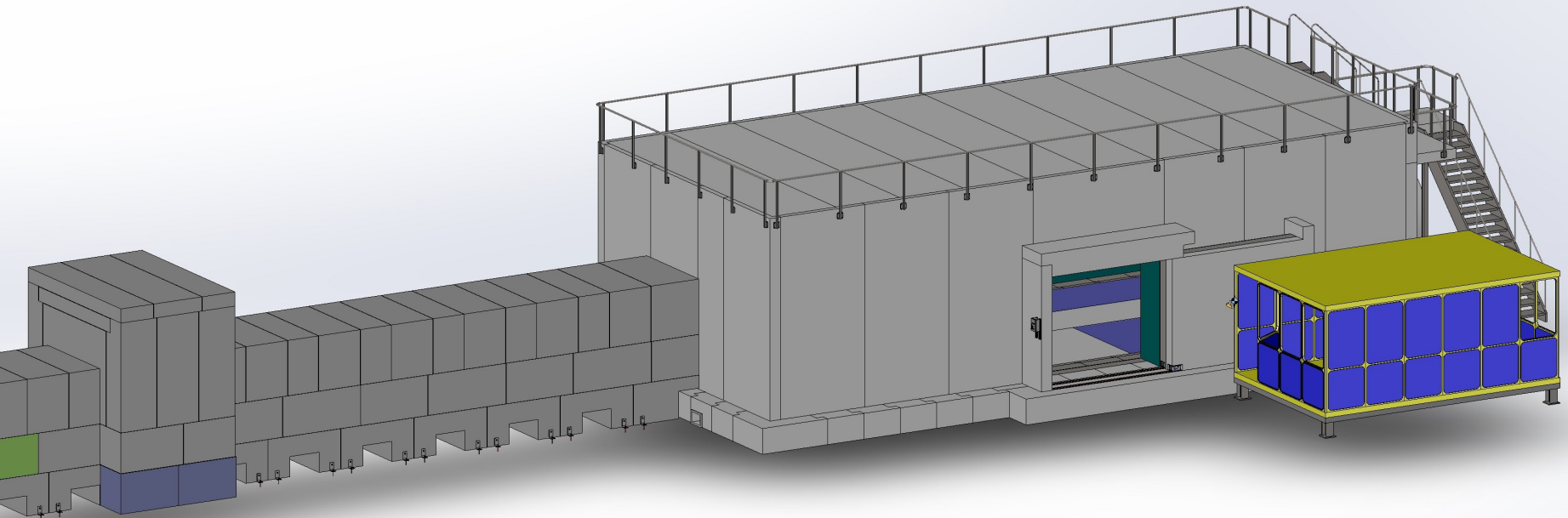
# Cave: Technical Design



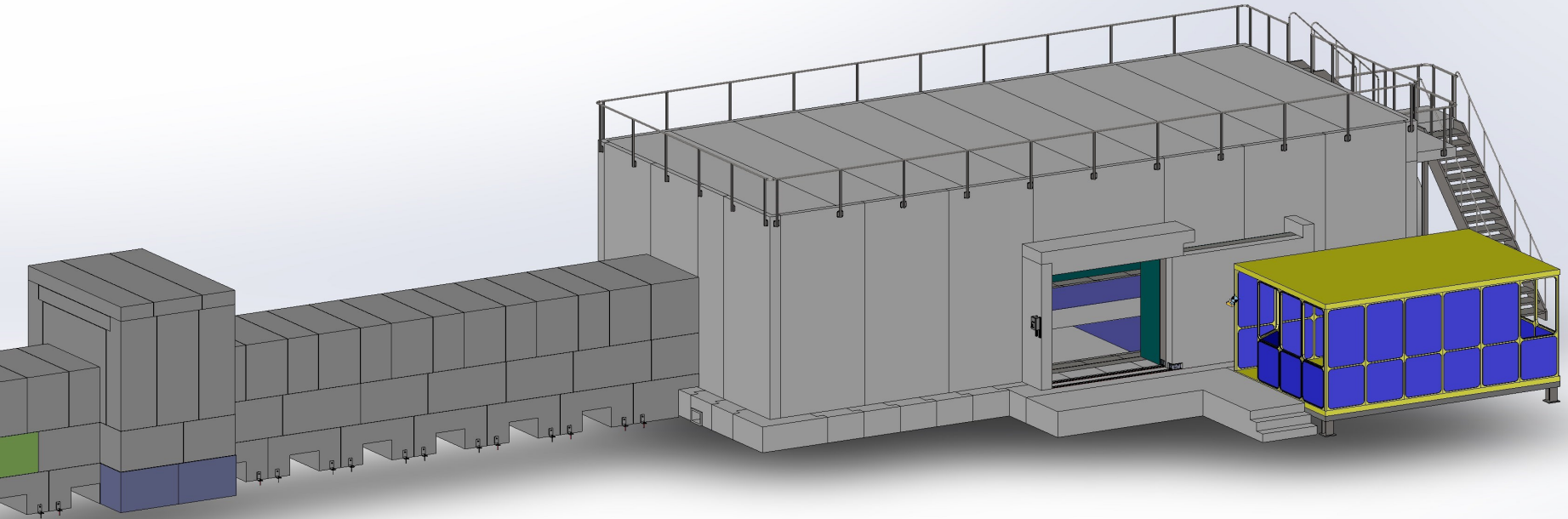
# Cave: Technical Design



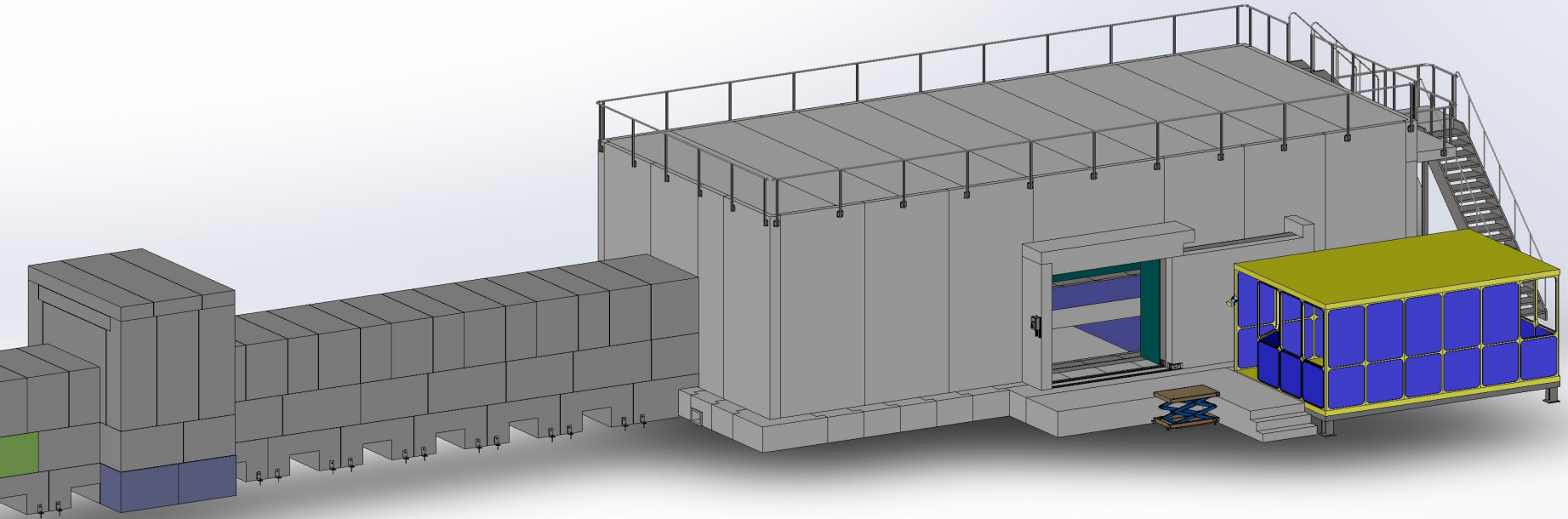
# Cave: Technical Design



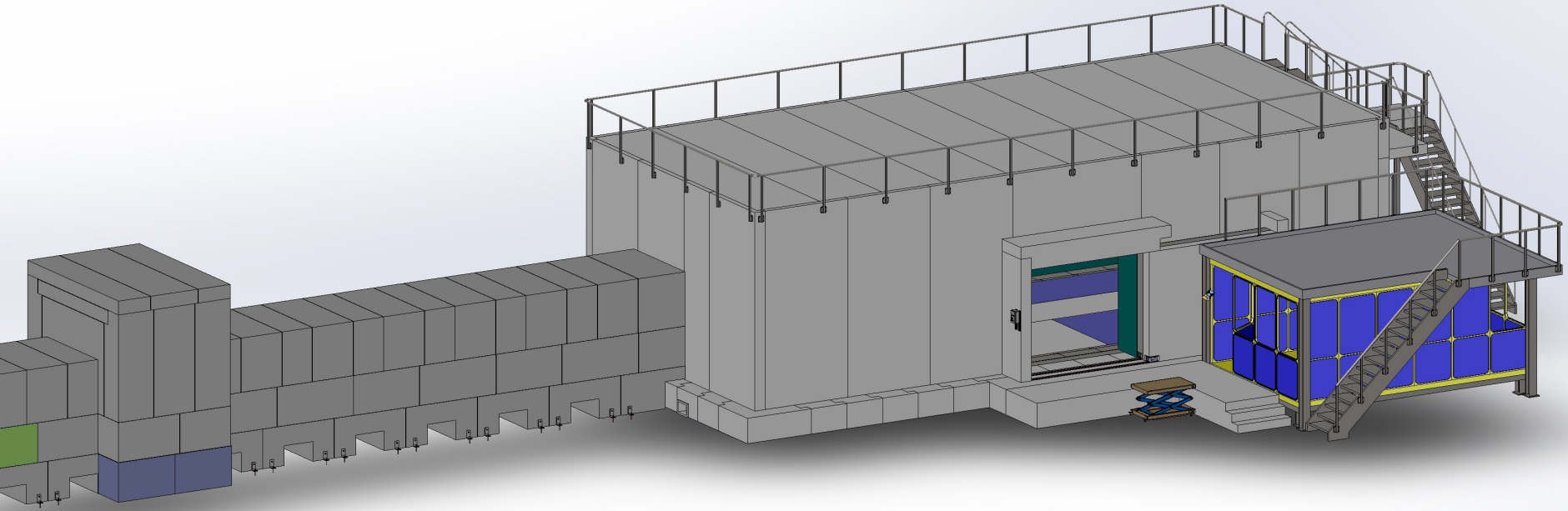
# Cave: Technical Design



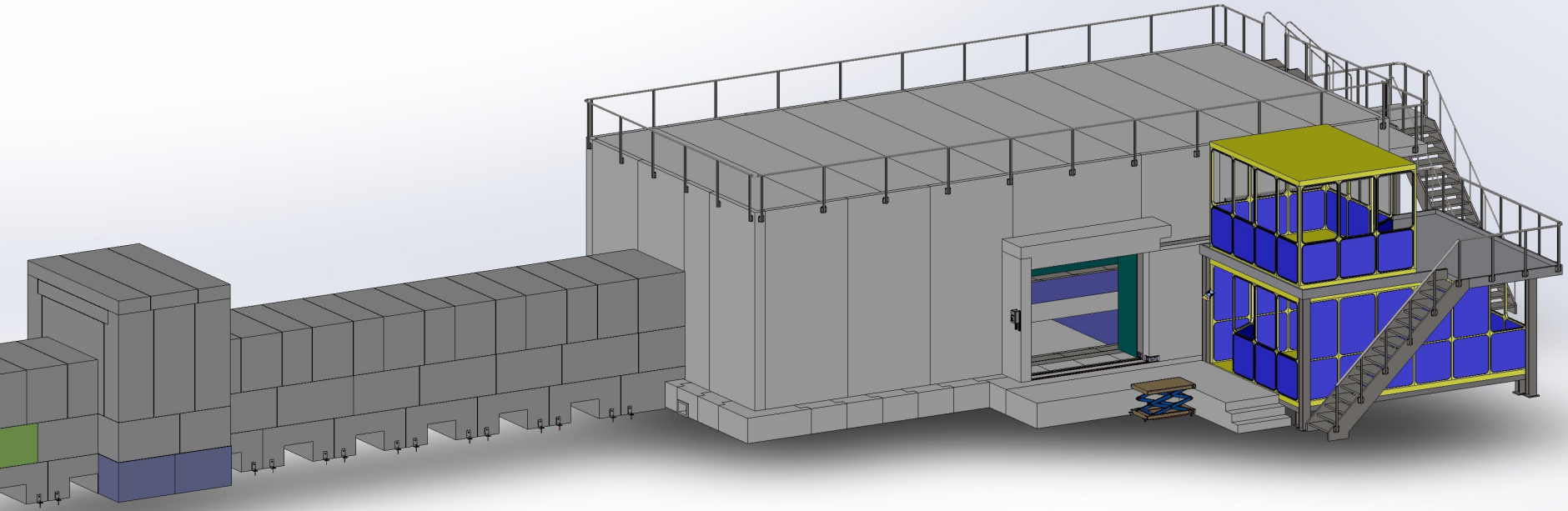
# Cave: Technical Design



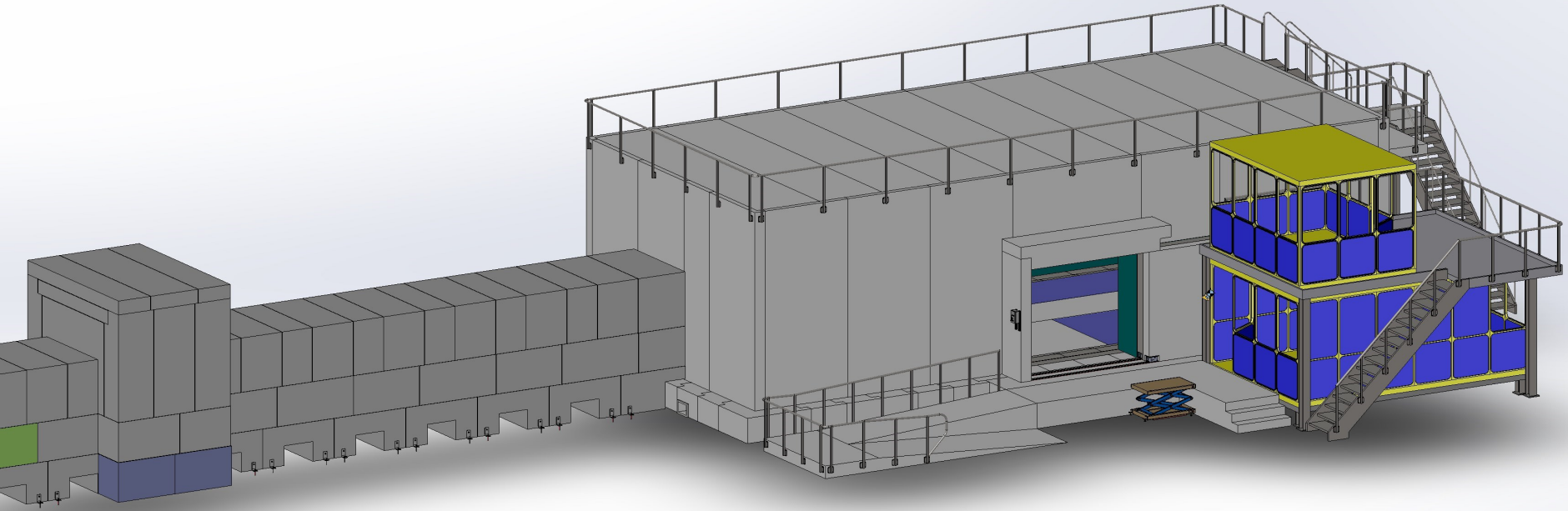
# Cave: Technical Design



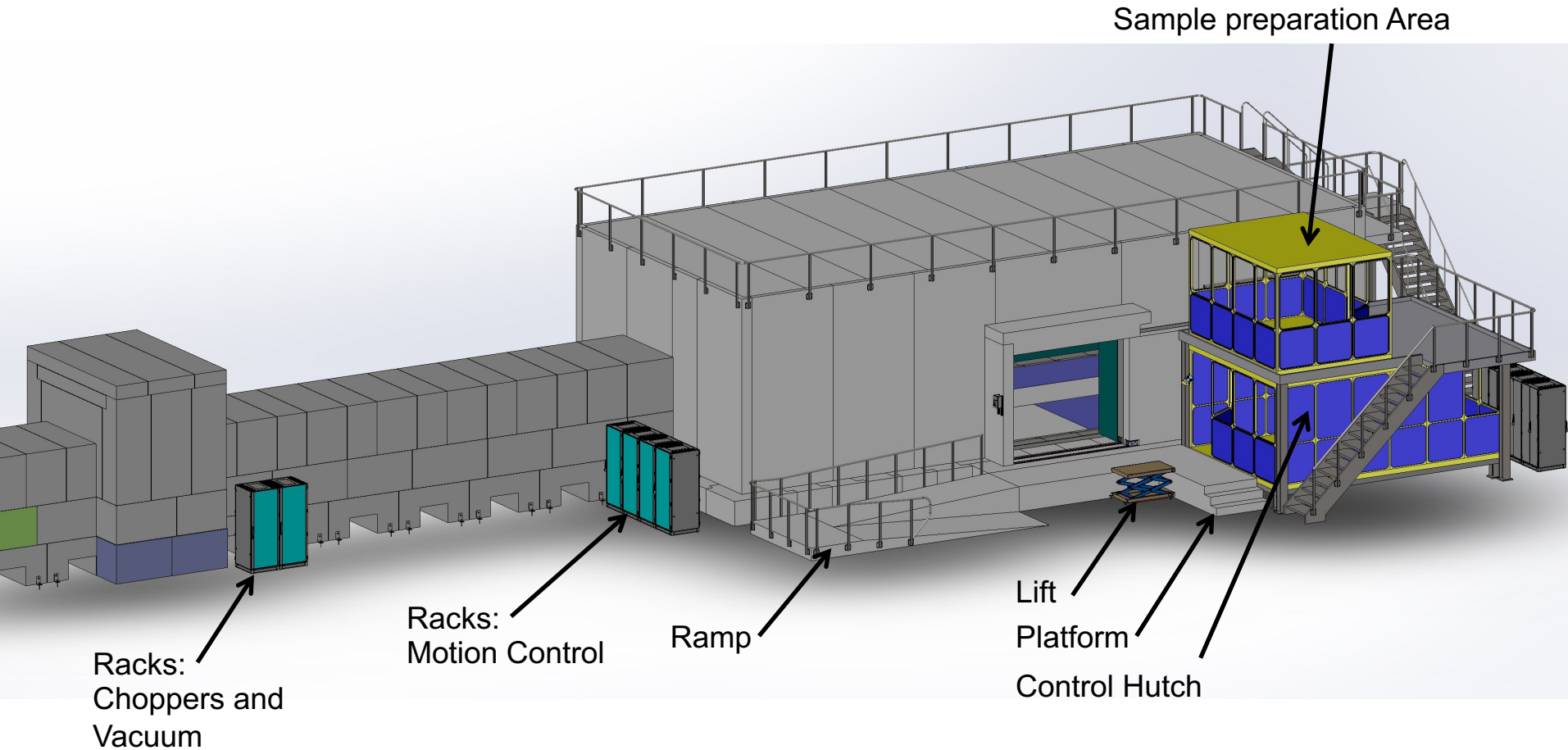
# Cave: Technical Design



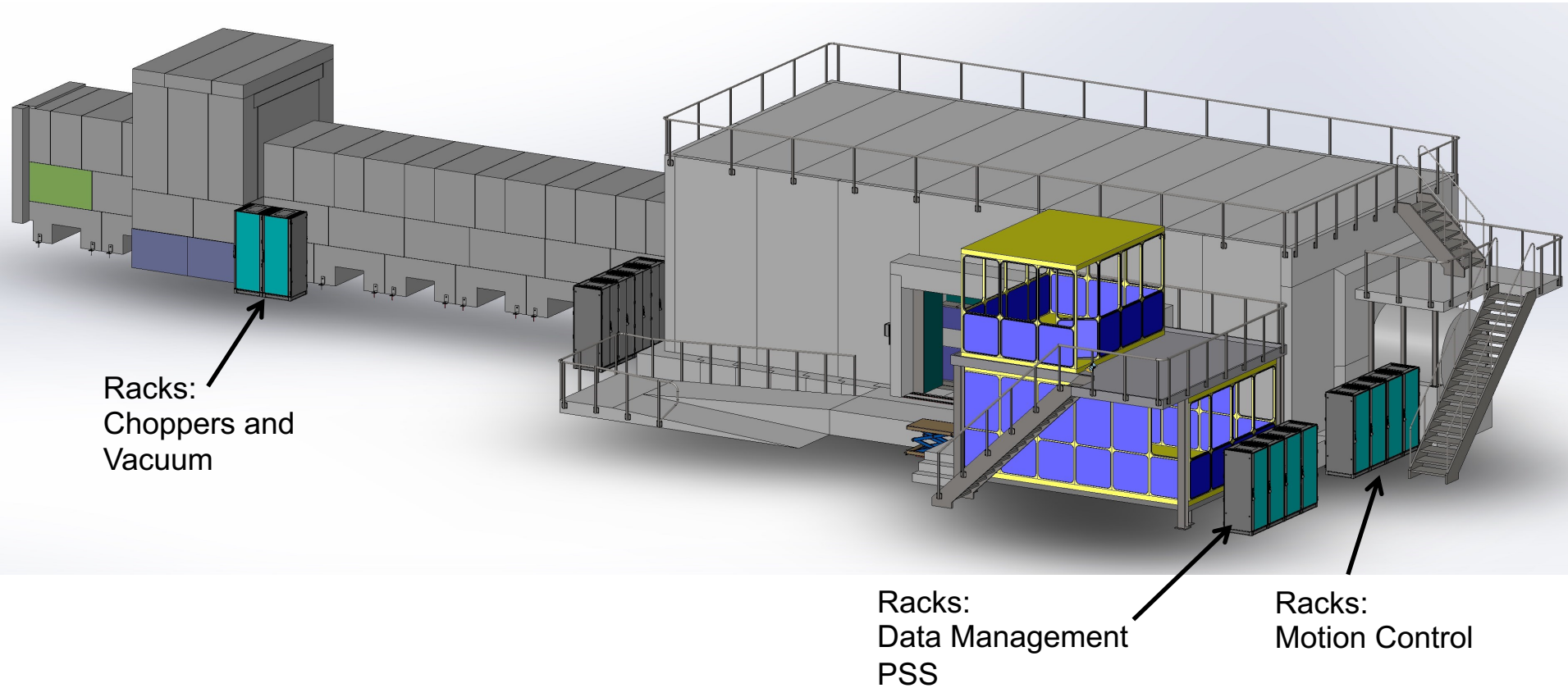
# Cave: Technical Design



# Cave: Technical Design



# Cave: Technical Design





Thank You!

