



**EUROPEAN
SPALLATION
SOURCE**



NSS Design and progress Ongoing projects

BBGOA's
In-Bunker Baseplates
Bunker wall steel feedthroughs

PRESENTED BY NICOLAS BRETON

2020-02-25

Summary



- 1 BBGOA's
- 2 In-Bunker Baseplates
- 3 Bunker-wall steel case for optics feedthrough
- 4 Installation mock-up in the E02 Halls
- 5 Projects forecasts

1

BBGOA's

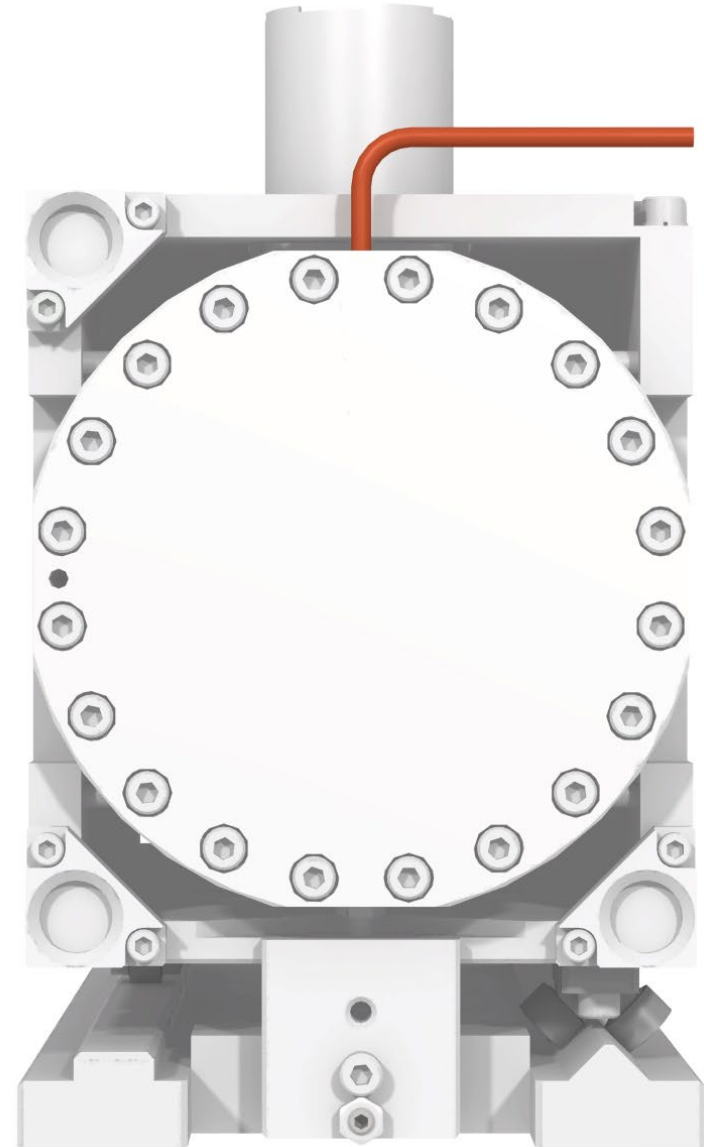

NSS Design and engineering Ongoing projects



1. BBGOA's

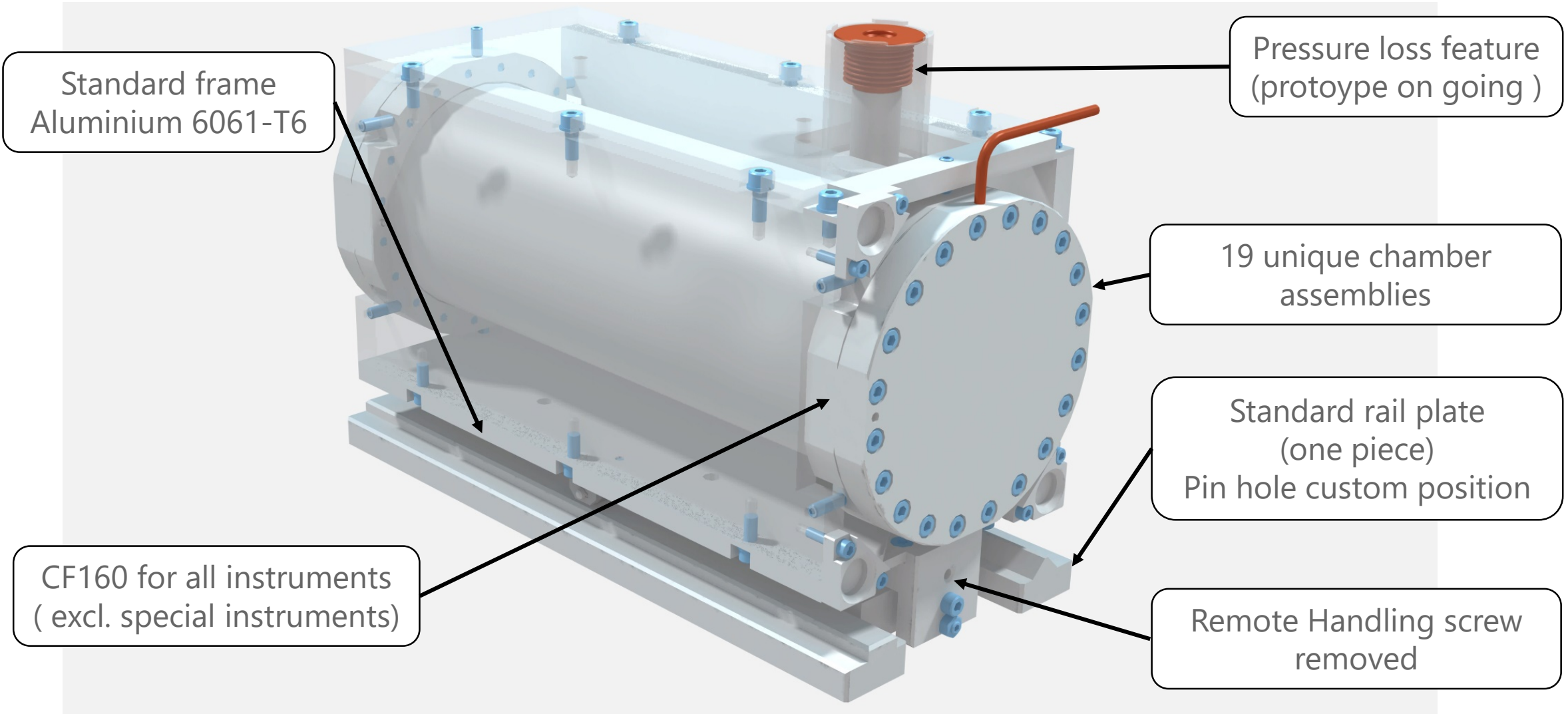

2

In-Bunker Baseplates

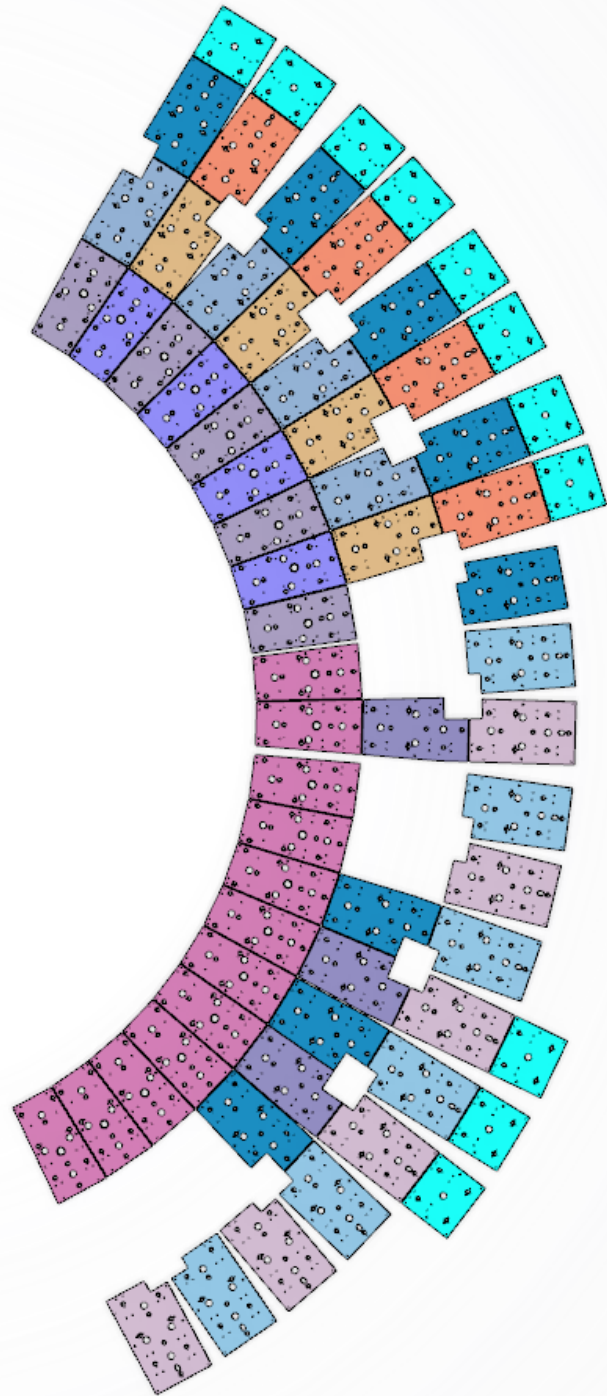

NSS Design and engineering Ongoing projects



2. In-Bunker Baseplates

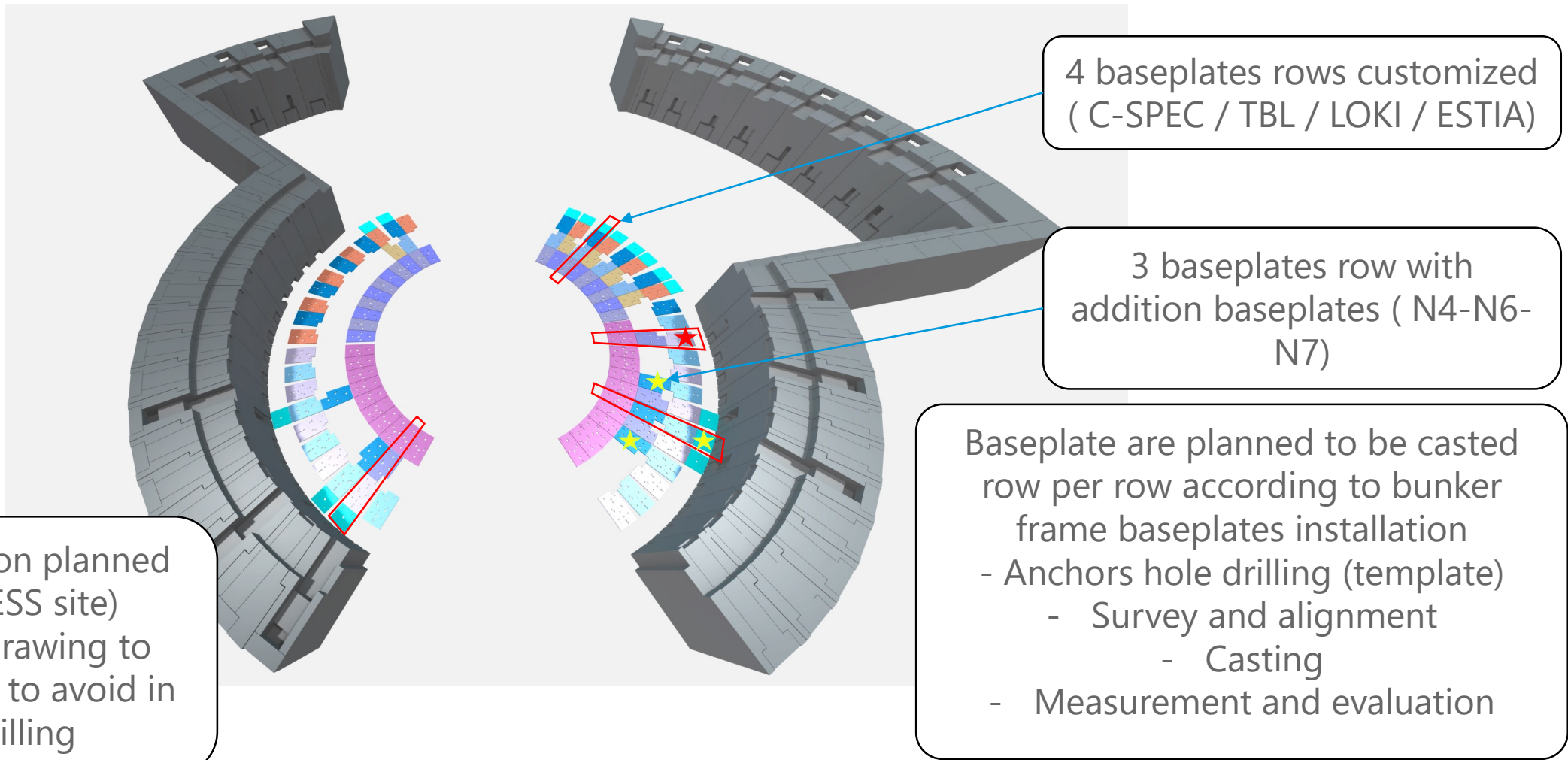

3

Bunker-wall steel case for optics feedthrough

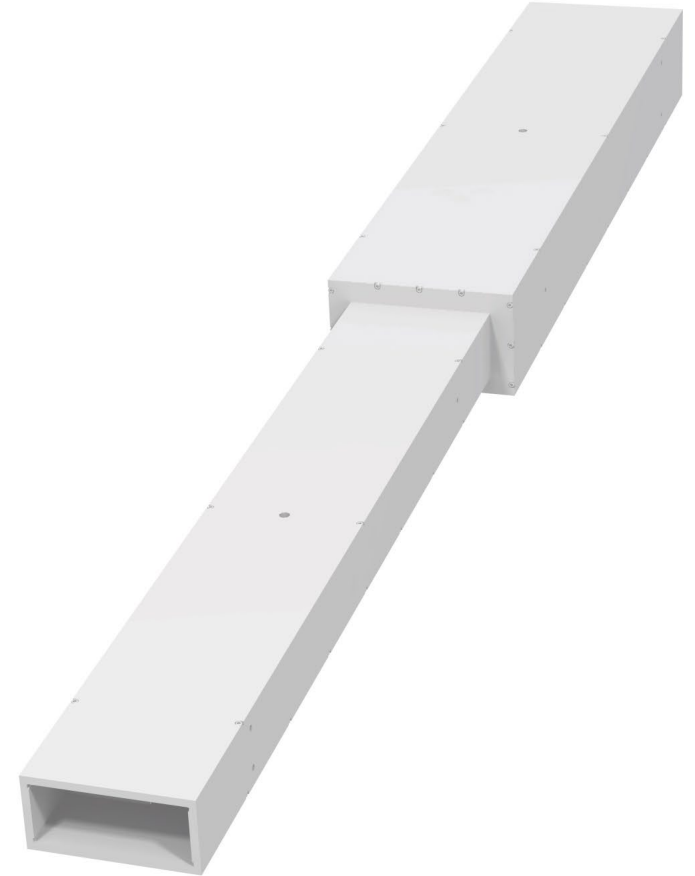

NSS Design and engineering Ongoing projects



3. Bunker-wall steel case for optics feedthrough

Goals

- Common shimming feedthrough solution for all 16 instruments
 - Different geometries
 - Different Coordinate systems (BFCS)
- Mitigate neutron streaming around the instruments optics feedthrough

Schedule & synchronisation

- Bunker wall blocks manufacturing
- Instrument guides feedthrough design

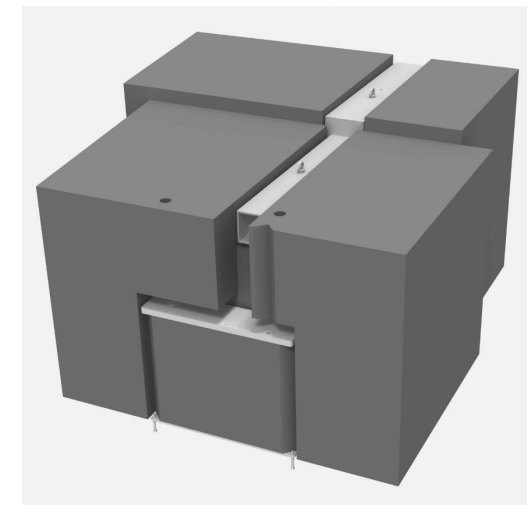
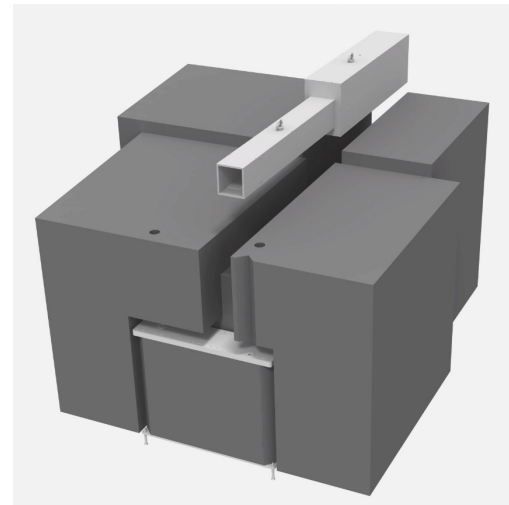
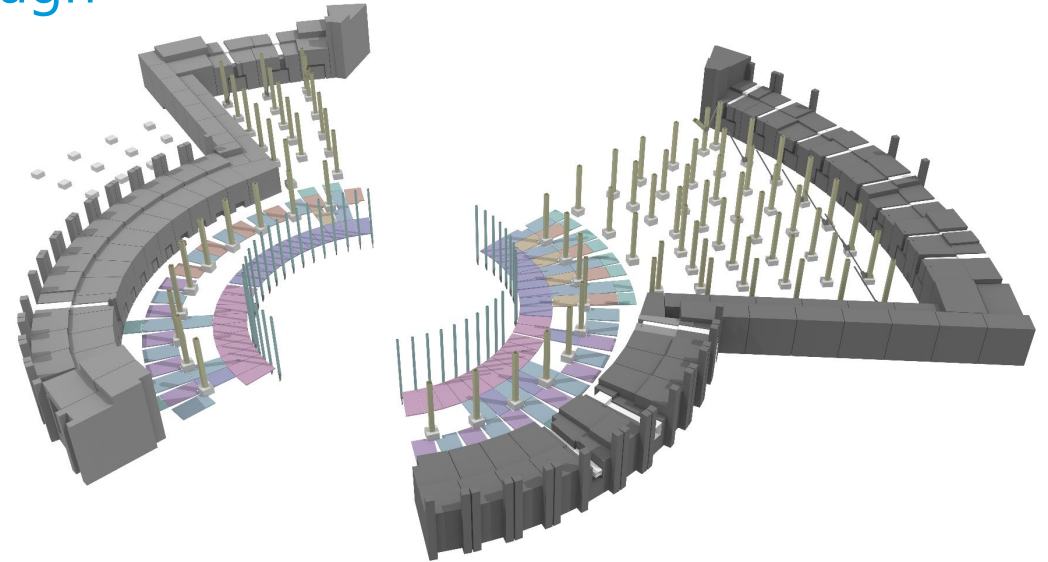

4

Installation mock-up in the E02 Halls



NSS Design and engineering Ongoing projects



4. Installation mock-up in the E02 Halls

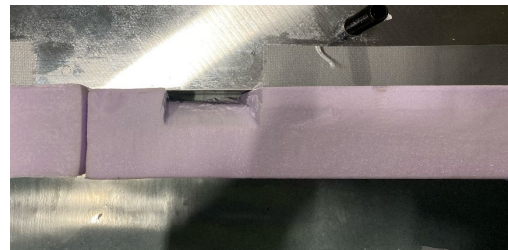
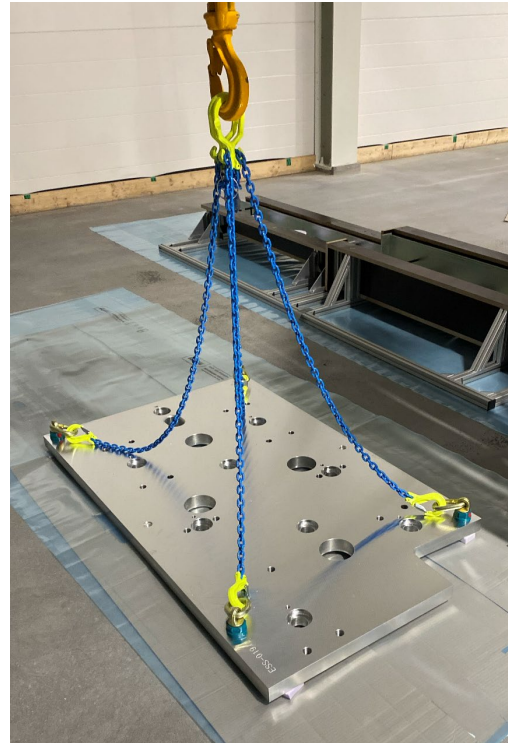

Baseplates rigging and preparation for grouting : Foamwork – tape – grease

NSS Design and engineering Ongoing projects



4. Installation mock-up in the E02 Halls

Installation feedback :

- Fluidity and pouring time needs to be well controlled (EXM 701 or equivalent required and 15-20 pouring time max

- No holes can be left uncovered and simple tape or plastic will deform (convex) under the expansion

- coverage and final aspect are as expected

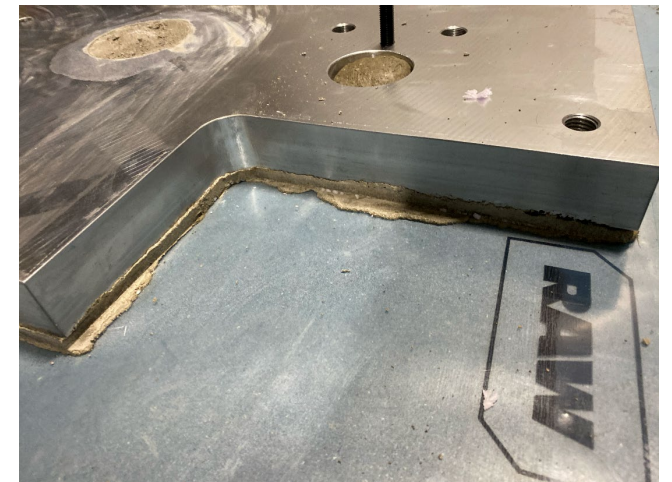

NSS Design and engineering Ongoing projects



4. Installation mock-up in the E02 Halls

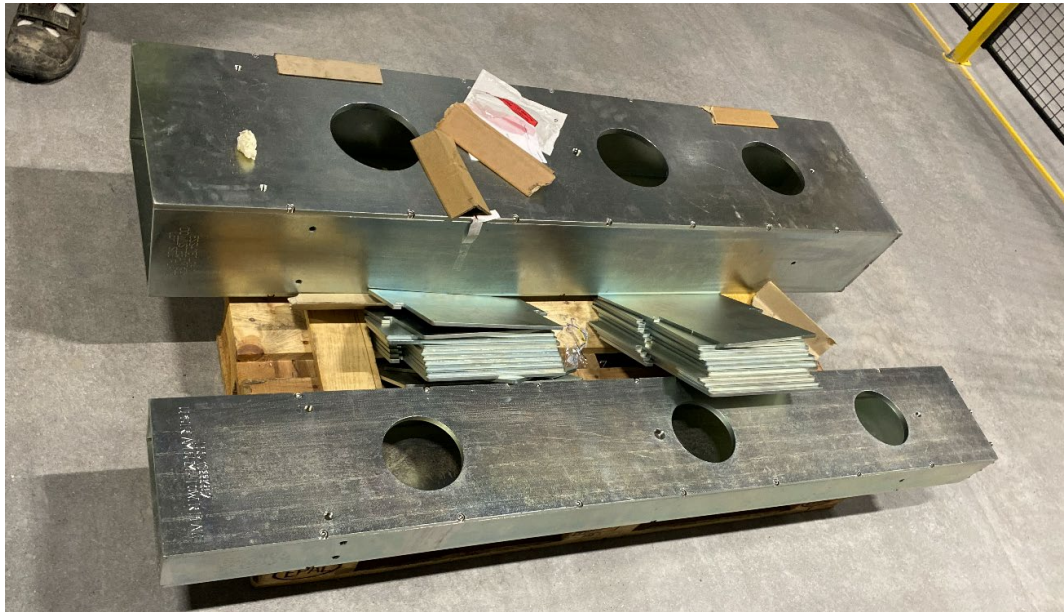

NSS Design and engineering Ongoing projects



4. Installation mock-up in the E02 Halls

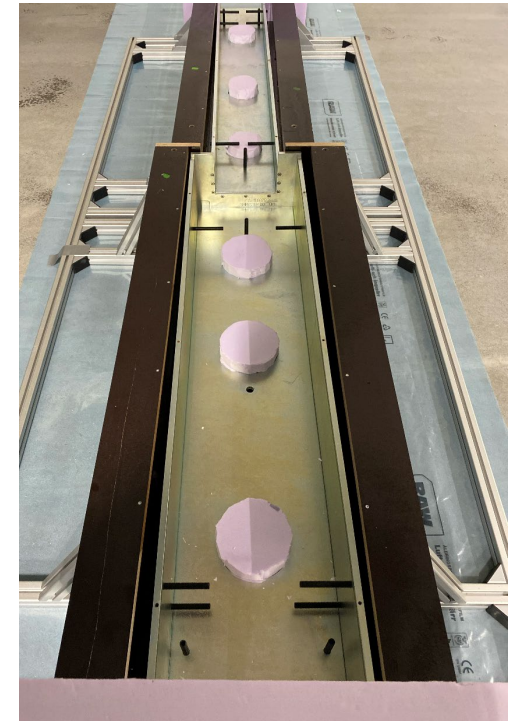
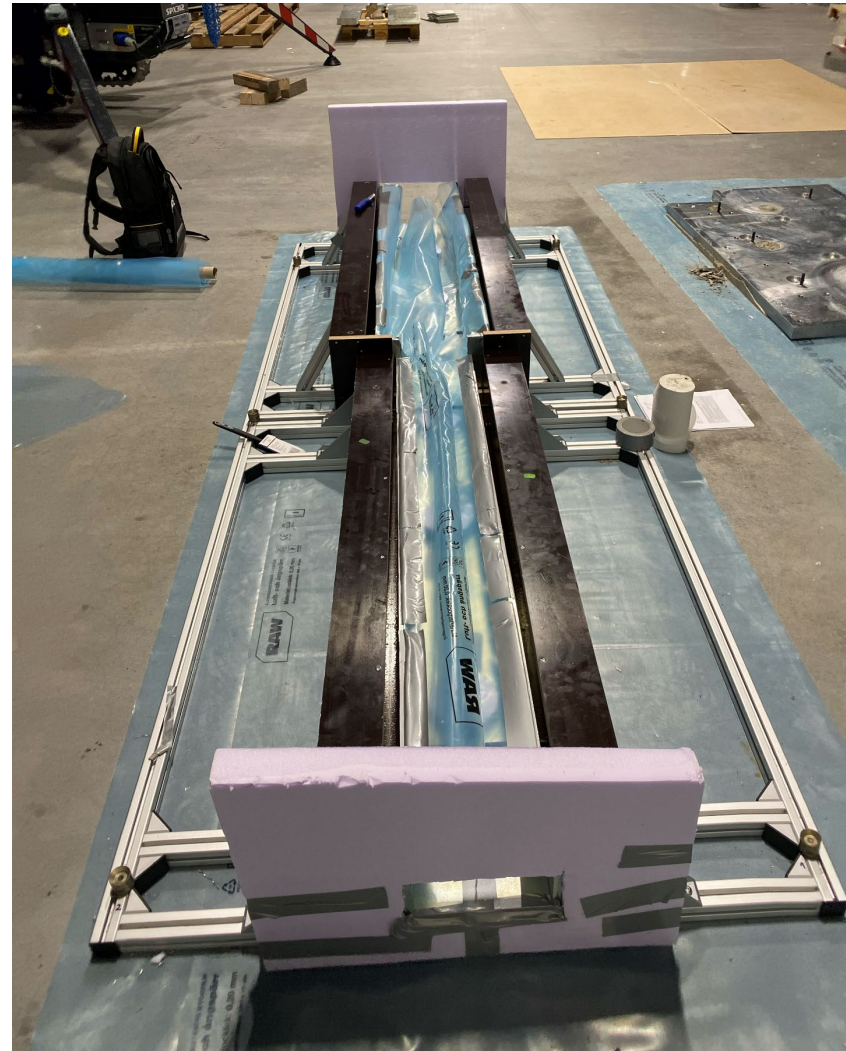
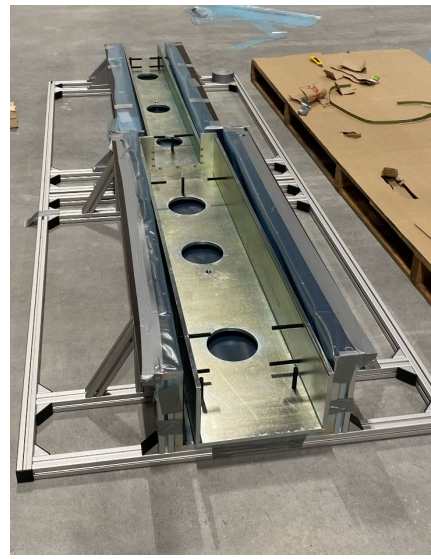

NSS Design and engineering Ongoing projects



4. Installation mock-up in the E02 Halls

- First grout step : Bottom layer
- Removal of the protection work
- Lid replacement and tightening
- Second grout step : Flush with "Bunker block)



NSS Design and engineering Ongoing projects



4. Installation mock-up in the E02 Halls

Installation feedback :

- Shaking was not advised (on the mock-up frame)
- Foamwork needs to avoid creating weak edges. (round shapes)
- Silicon gun should be used in addition to tape to avoid leakage du to the expansion
- Additionnal set screws for beam direction
- Grouting holes were not used to be removed



5

NSS Project forecast

NSS Design and engineering Ongoing projects



5. NSS Projects forecasts

BBGOA's

- Pressure loss prototype to be concluded around end of march
- BBGOA prototype to be ordered after (end march/april)
- BBGOA will be installed in accordance to instrument schedule

IN-BUNKER BASEPLATES

- Attempt to do a second cast (EXM 701 to be used)
- Customization in the TTC starting in March-April
- The baseplates will be installed according to the Bunker frame baseplates schedule

BUNKER WALL FEEDTHROUGH

- Design to be updated
- Procedure and documentation will be produced according to installation feedback
- The bunker wall Feedthroughs sleeves installation will match the Instrument installation schedule



Thank you for your attention