

# MIRACLES: STAP Spectroscopy report (October 2019 – March 2020)

Félix J Villacorta, on behalf the MIRACLES team

## General information

In January 2020, the In-Kind Review Committee approved the MIRACLES Technical Annex for Phases 2-4 (Detailed Design, Manufacturing and Installation).

Although human resources are incorporating to deal with mechanical design, electrical design, control and safety, our Lead Engineer, Paula Luna, left in December. We are in the process of hiring a new engineer: however, the process has been frozen due to the COVID-19 new policy for priority reassignment in the Spanish Administration.

An overview of the status of the MIRACLES project is outlined here, from source downstream.

## NBOA

The Neutron Beam Optical Assembly, NBOA passed the CDR/TG3 review in January. Material was procured and manufacturing initiated. However, the fabrication of this component has stopped, due to the COVID-19 crisis. The main cause is the unavailability of neutron sources to carry out reflectivity measurements. This will imply subsequent delays to the delivery of the system.

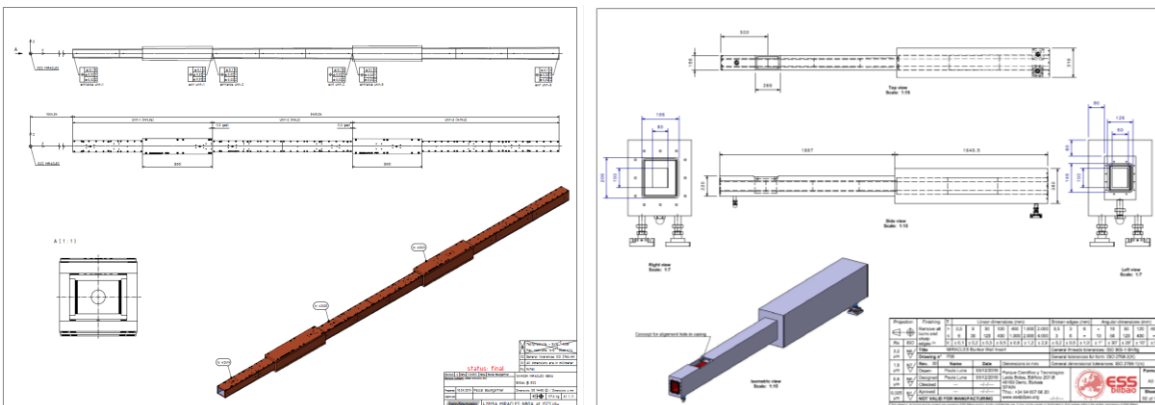

Fig. 1. Drawings of MIRACLES NBOA and BWI, respectively

## BWI

The technical specification document for the tender of the Bunker Wall Insert (BWI), the guide segment passing through the bunker wall, was submitted to the ESS for final approval. However, the ESS decided to postpone guide procurement for the instruments 9-15 until July 2020, so final approval will be expected by that time.

## Beam monitors

MIRACLES has expressed interest in joining the ESS beam monitor common project, The uncertainties regarding the first beam monitor after the selection chopper (used as a time reference and pulse duration diagnosis), related to its lifetime and performance are still present, but we consider that to tackle this issue it is better to establish a common and collective effort. Options for this beam monitor are a fission chamber or a GEM monitor.

The final layout includes also one beamline monitor, just after the last chopper, for calibration of flight paths and choppers diagnosis, one normalization monitor, just before the sample, and one transmission monitor after the sample, before the get-lost tube.

## Secondary Spectrometer

The secondary spectrometer (vessel and in-vessel components) was evaluated in a conceptual design review before tendering. The review took place in March, with experts in neutron backscattering spectroscopy involved in the panel. In this review, the backscattering geometry and design solutions were presented. Magnetization of the vessel was discussed and COMSOL simulations were presented, considering the effects of ferritic regions due to welding.

Recommendations from the panel include a revision of the vessel's design, with particular attention to effects of vessel wall deformations in the sample positioning and the analyzer tilting, and the reduction of the vessel radius. An improved vacuum level inside the vessel is also suggested. Additionally, the panel recommended that a more detailed alignment strategy should be drafted before procurement. Also, it was suggested that procurement should be split into the components that take part of the secondary spectrometer (vessel, analyzer, radial collimator, slits, detectors/electronics support structure, get-lost tube).

Additionally, the experimental strategies presented to test the U-connection of  $^3\text{He}$  tubes to the detector electronics and to confirm/optimize the final thickness of the Si(111) crystals, in which reflectivity, energy resolution and mechanical constrains were considered, were well received by the review panel.

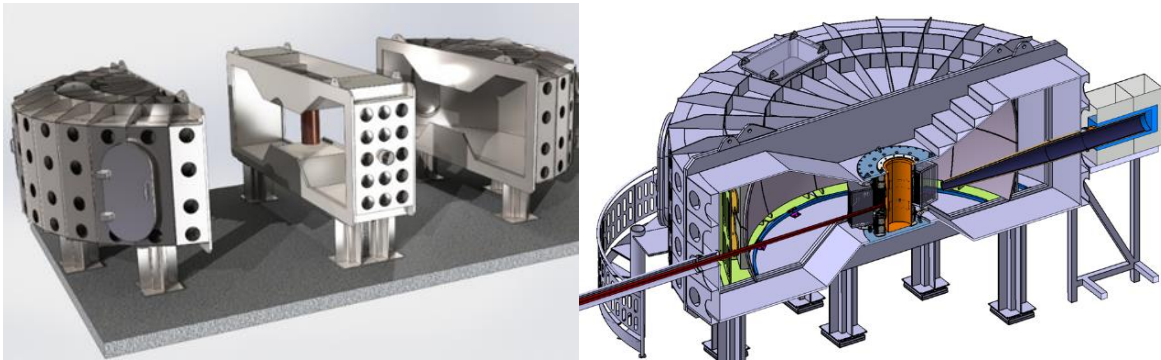

Figure 2. Exploded view of the vacuum vessel, showing the modular design with the 3 units. CAD model of vessel and in-vessel components (radial collimator, detector tube array and analyser system).

## Cave design

Design tasks to give final shape to the MIRACLES cave are ongoing. After providing a final concept for the sample hatch, the final dimensions and design of the cave are waiting for final approval of the H1-H2 scenarios (normal operation and accidental events) document, that was submitted in January to the ESS. Current efforts are focused on the utilities and electrical distributions.

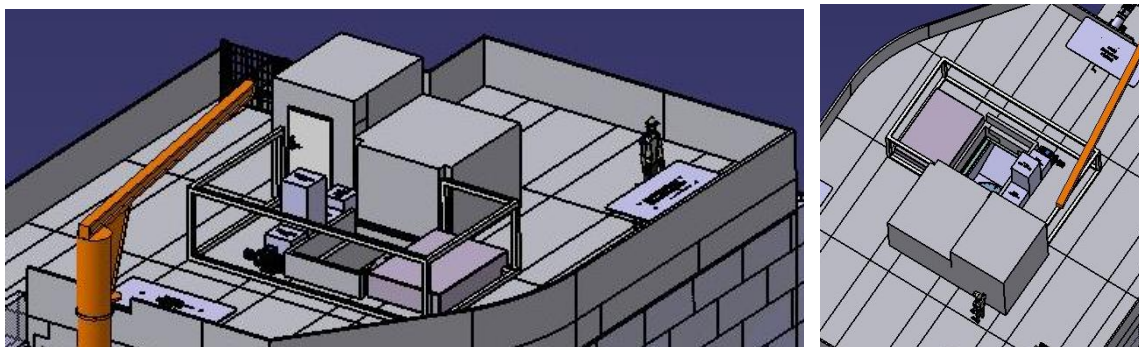

Fig. 3. Illustrative picture of the final sample loading area (hatch) and cave's roof layout.