

Residual stress measurement in dissimilar metal joints using neutron diffraction

Presenter: Thaneshan Sapanathan¹

Contributors: N. Jimenez-Mena¹, J.M. Drezet^{2,3}, S. Cabeza³,
T. Pirling³, P. J. Jacques¹, A. Simar¹

1 UCLouvain, Institute of Mechanics, Materials and Civil Engineering (iMMC)

2 École Polytechnique Fédérale de Lausanne

3 Institut Laue-Langevin

Outline

- Dissimilar welded joints – by friction melt bonding
- Neutron diffraction experiments
- Pseudo peak shift correction for the geometrical origin
- Interface tracking using neutron diffraction intensities
- Residual stresses at welded sample and near interface
- Examples of Residual stress in various process conditions

Dissimilar metal joints



Steel to aluminum
Friction melt bonding joint

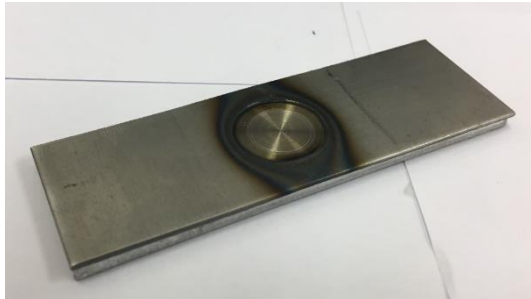

Steel to aluminum
Friction melt spot joint



Steel to aluminum
Friction stir weld



Copper to aluminum
Magnetic pulse weld

Friction Melt Bonding (FMB) – Steel to aluminum joint

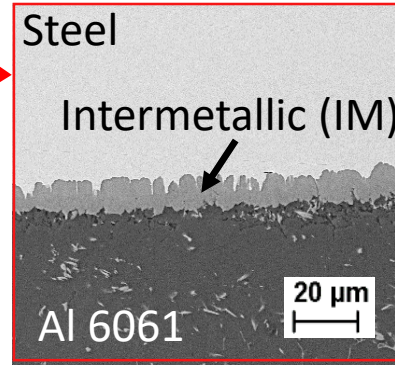
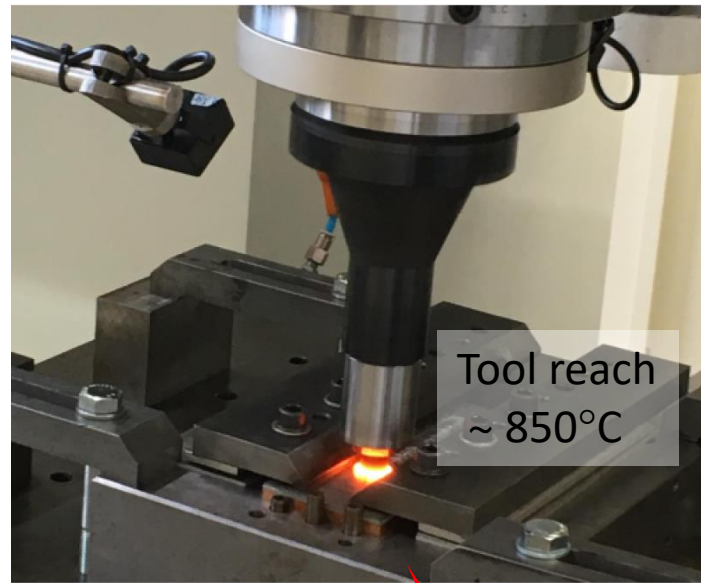
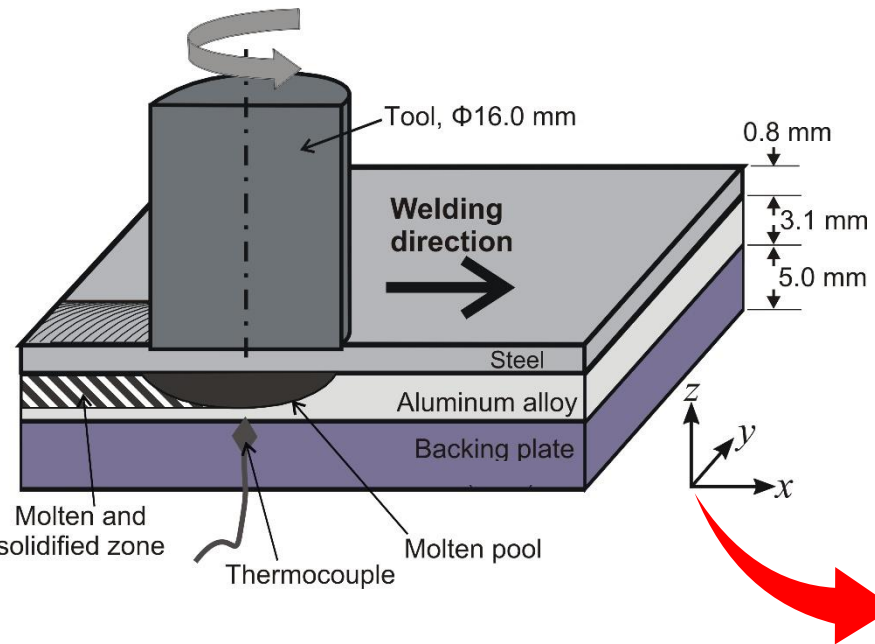

- Join metals with large differences in melting temperature
- Use of a simple cylindrical tool (without pin)
- Process developed at UCLouvain in 2014

Residual stress measurements

- Firstly, a proof of concept measurement for completely dissimilar material is established
- Measurements were performed using Neutron diffraction at ILL
- Nominal gauge volume of $0.6 \times 0.6 \times 2$ mm
- $\{211\}$ peak in steel, and $\{311\}$ peak in Al alloy are used

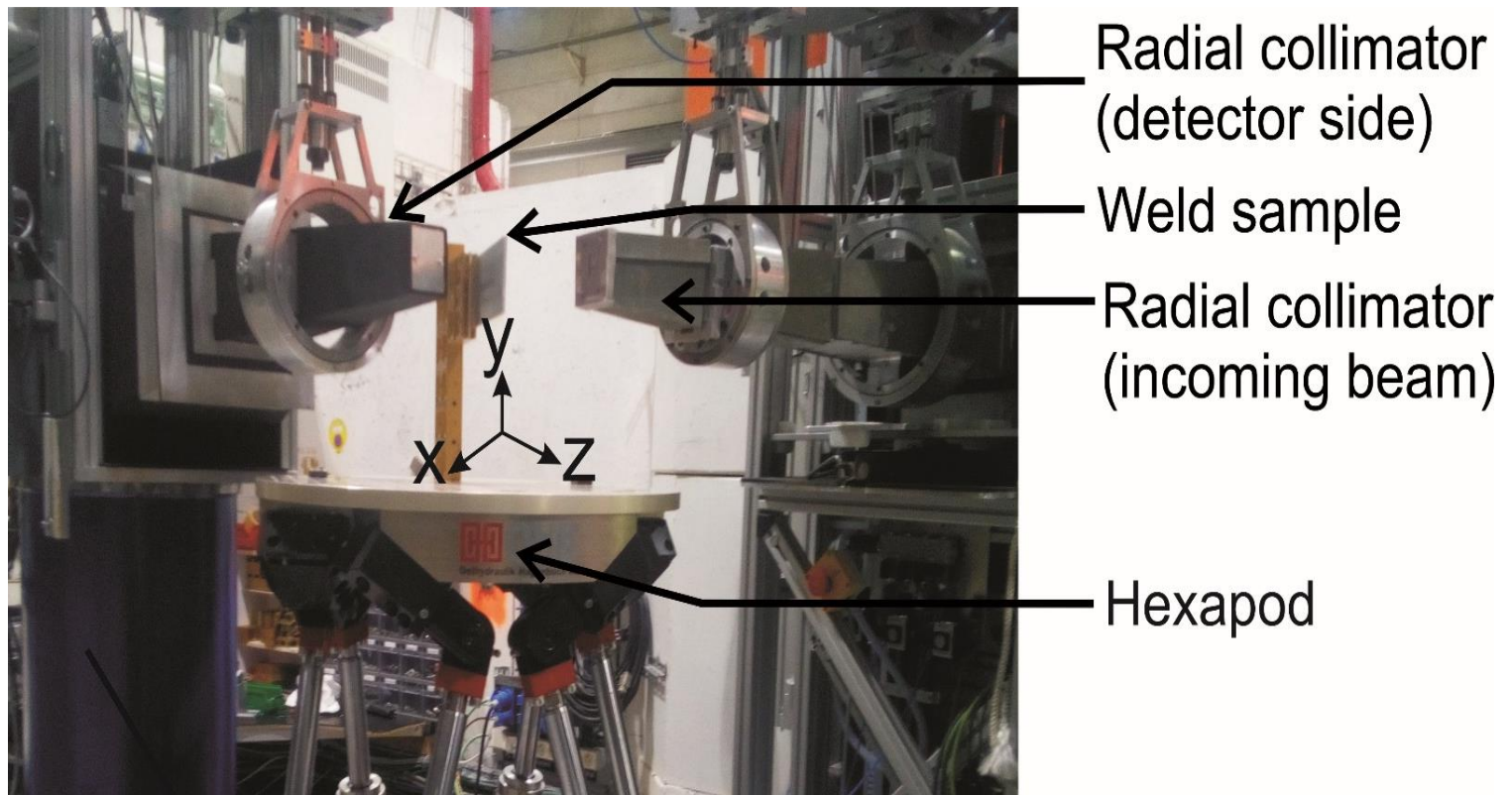

Strain Analyser for Large and Small scale engineering Applications (SALSA) at ILL

Measurement plane in the FMB sample

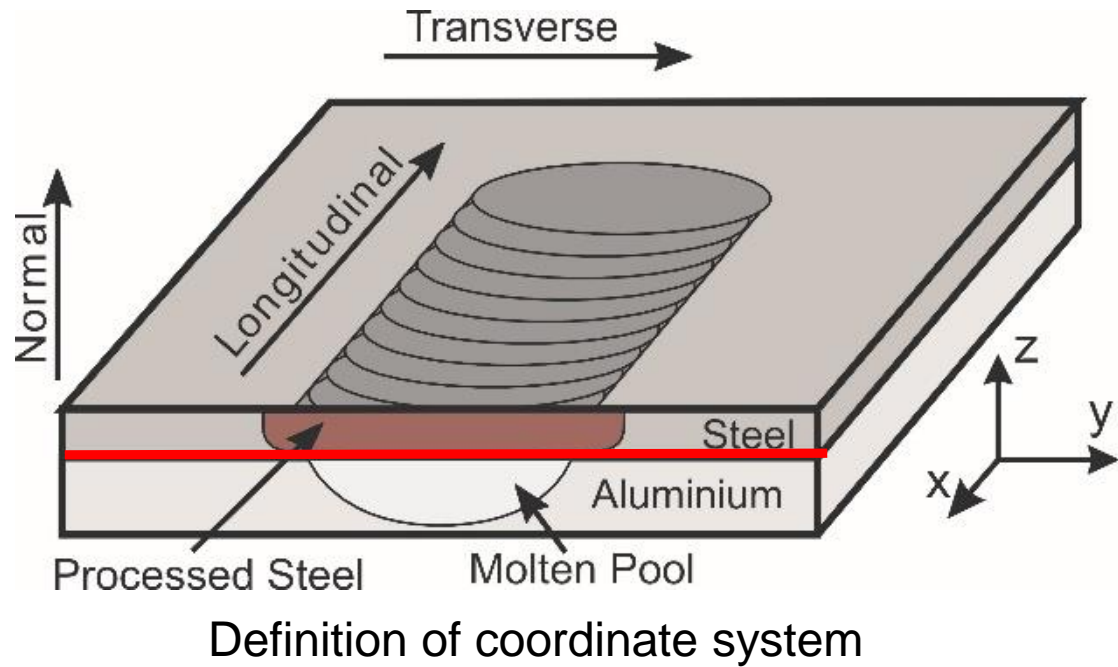
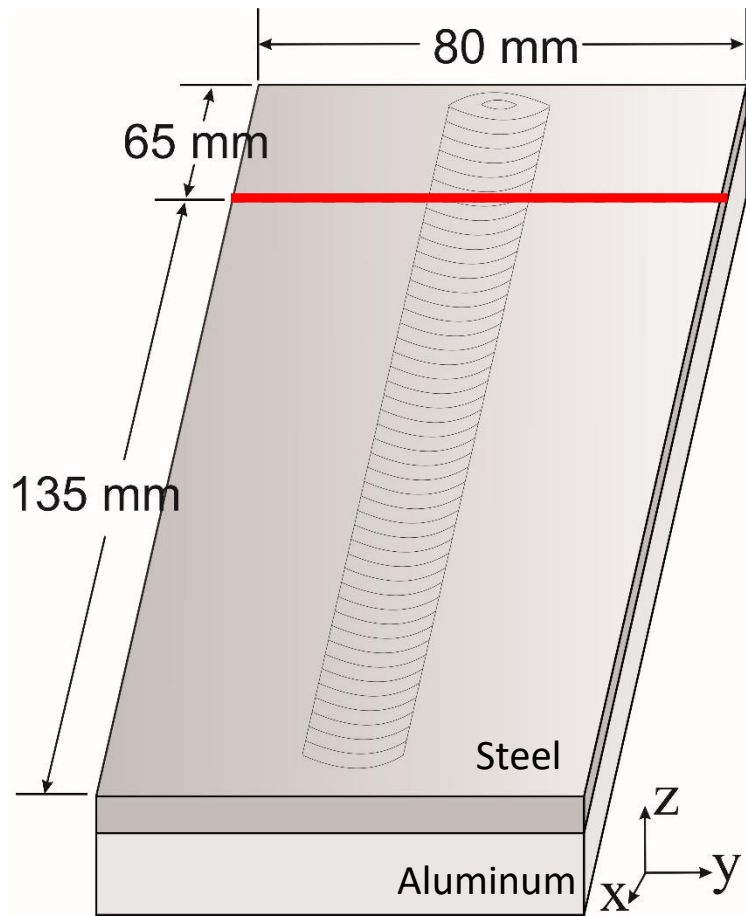

Location of the measurements

[FMB: Friction Melt Bonding]

Sources of artificial peak shifts in Neutron Diffraction

- Wavelength distribution -> The use of Si-bent monochromators provides a beam that shows a non-constant wavelength across the beam width. This effect can be avoided using radial collimators at the primary beam



- Peak clipping effect -> also eliminated by a radial collimator placed before the detector



- Attenuation -> Negligible for small gauge volumes



- Geometric -> Displacement of the gravity centre of the measurement compared to the centre of the gauge volume

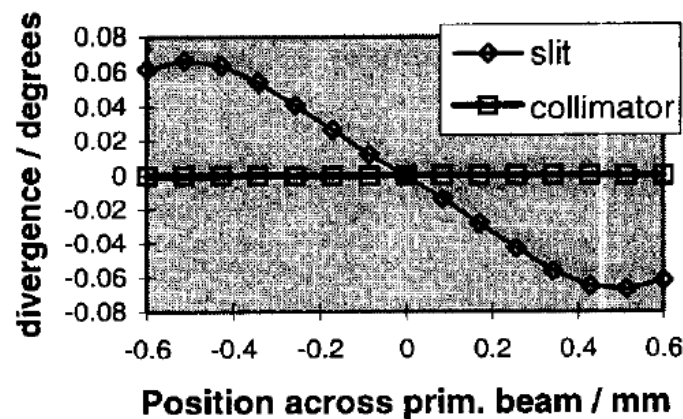

Pirling 2010, ILL

0.5mm Radial collimator

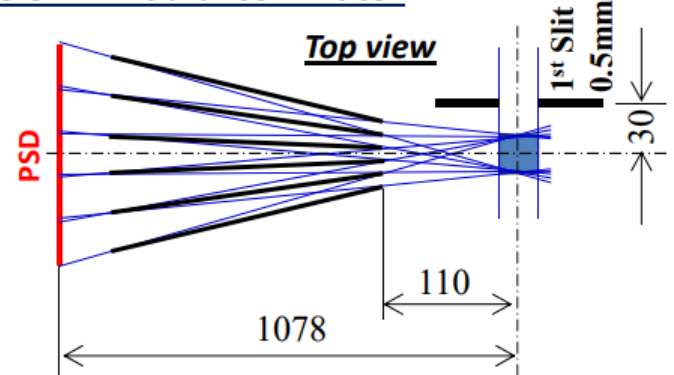

Suzuki et al.

Geometrical origin of the artificial shift at interface

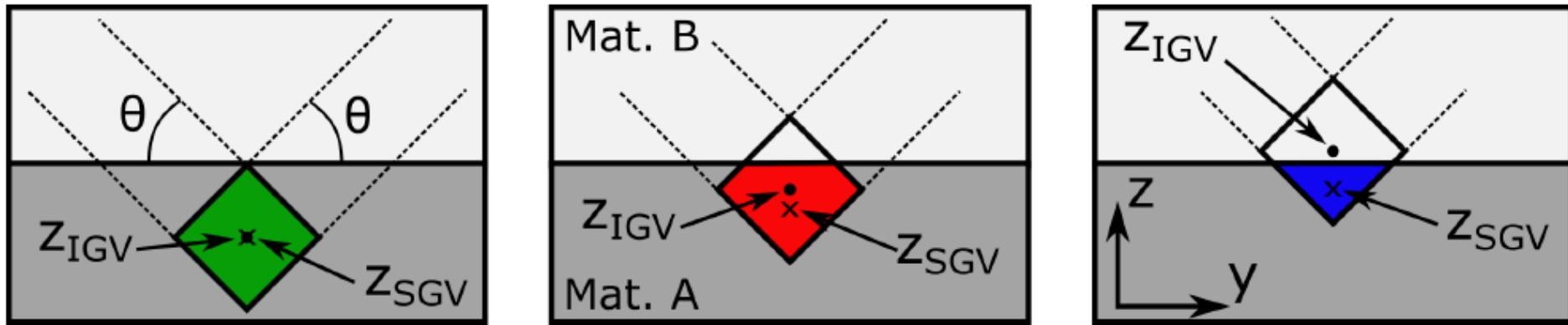

Interaction between the gauge volume and the sample surface Material B could either be air or the another material [IGV – Instrument Gauge Volume & SGV – Sampled gauge volume]

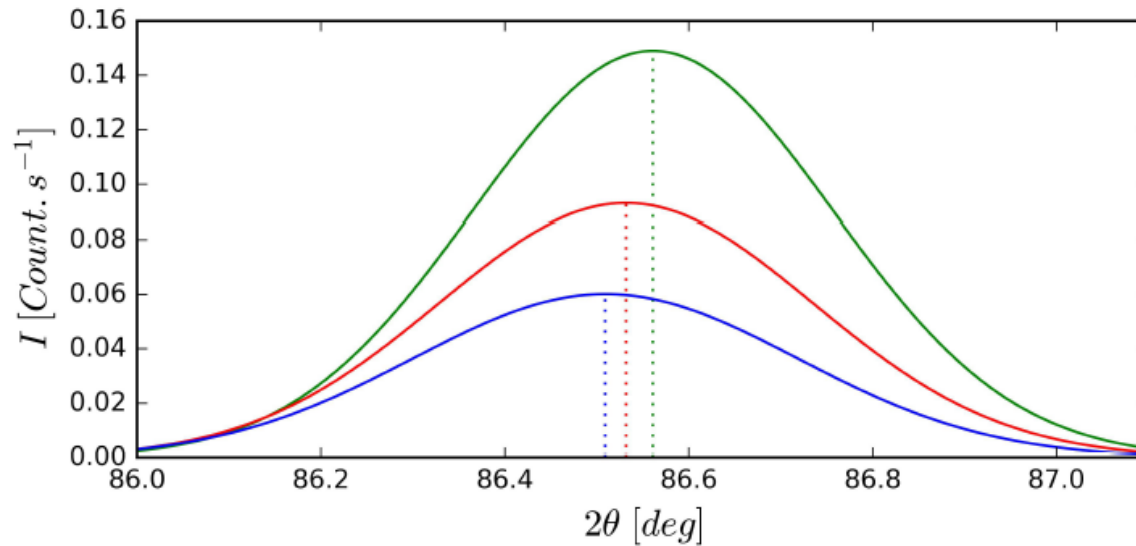

Wang et al. 1997

Sampling points of neutron diffraction to determine the interface

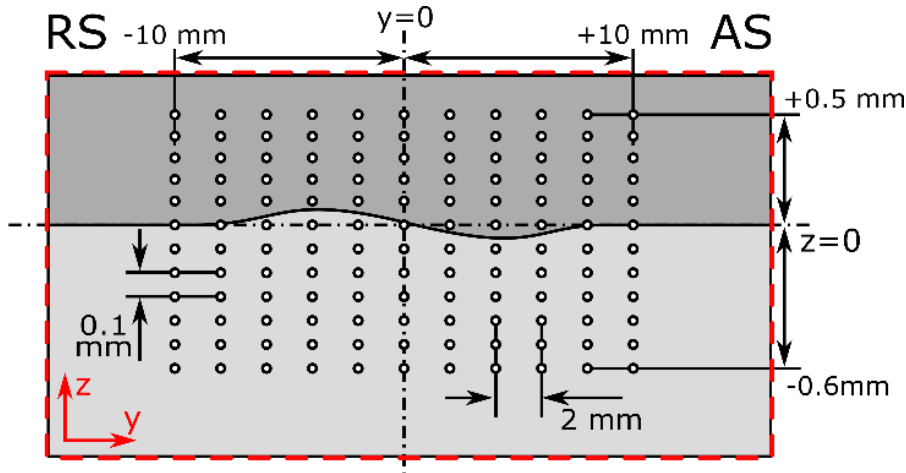

Positive y – Advancing Side (AS)
 Negative y – Retreating Side (RS)

Transverse cross section with small step scan

- Small step scans were used to find the geometrical origin of the artificial shift
- Finding are validated with the interface position
- This diffractions were performed only for Steel {211} peak

Reference pseudo shift using Stress free steel plates

0.31 mm thick plate

0.23 mm thick plate

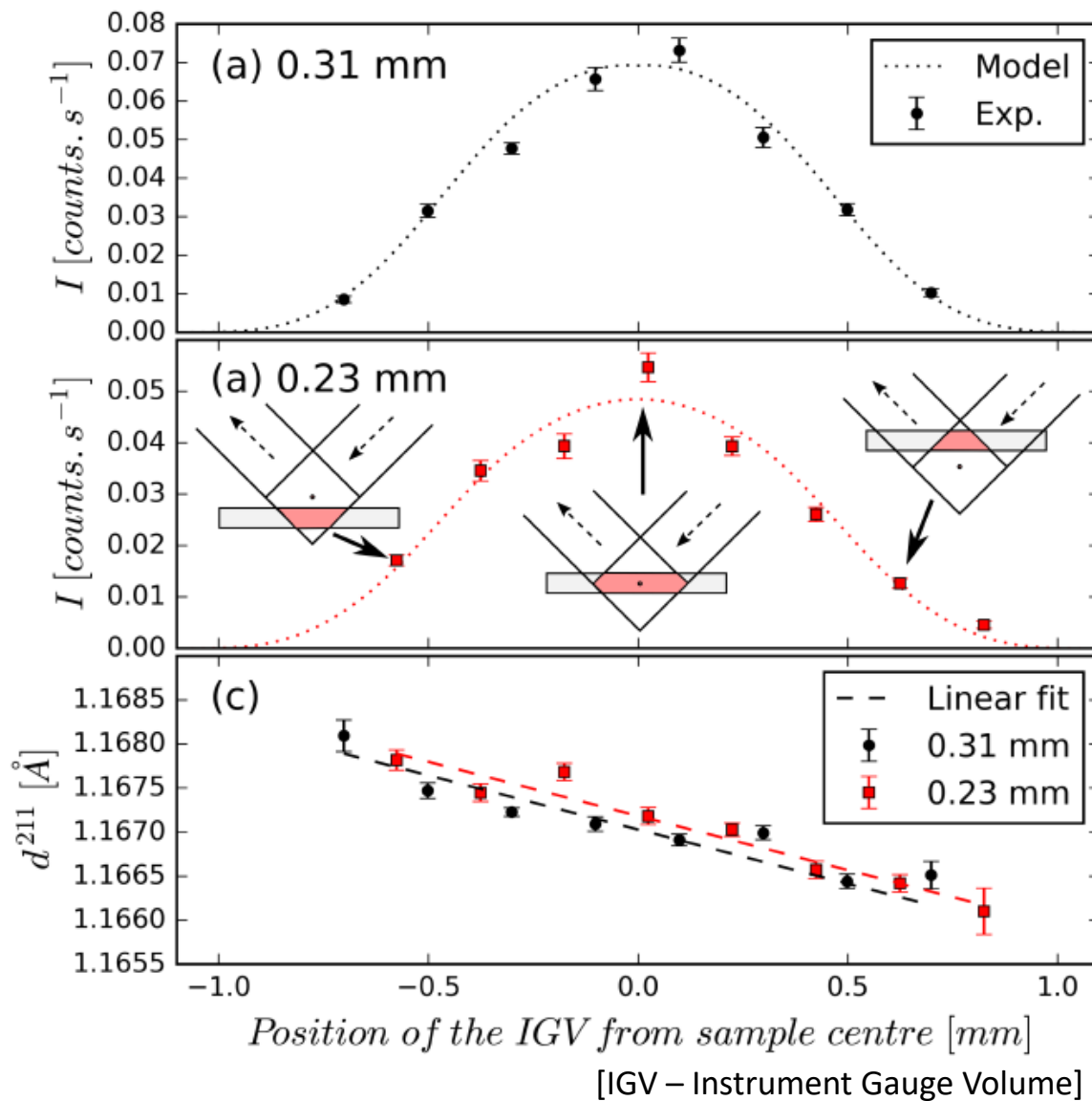

Interface position information using neutron diffraction

Relative intensity in the normal direction.

- The change in intensity is sufficient to track the interface
- The intensity decreases as the gauge leaves the steel plate (into Al plate)
- The maximum intensity I_0 is given when the gauge is completely inside the material
- Location of the interface is identified using a modeled solution.
- i.e. the shift of the model is recorded as the interface position

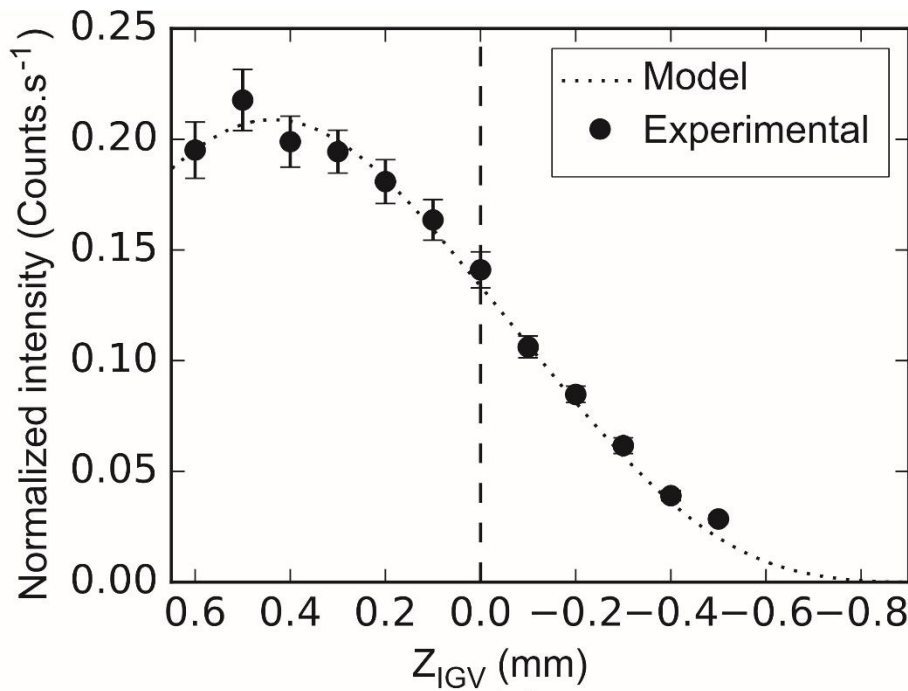

e.g. $y = -4$

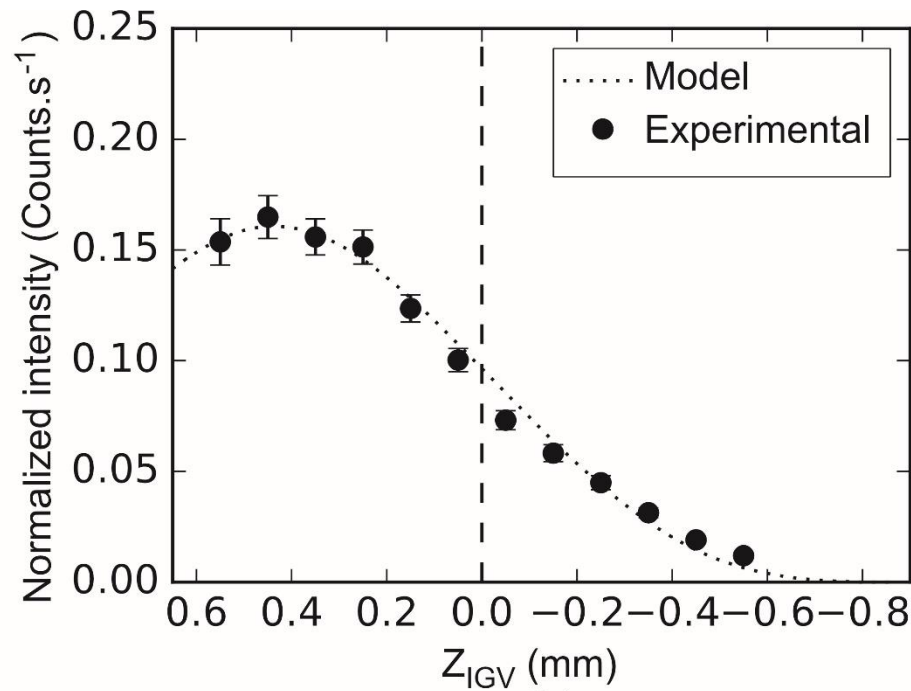

$y = +4$

Interface position from SEM and neutron diffraction

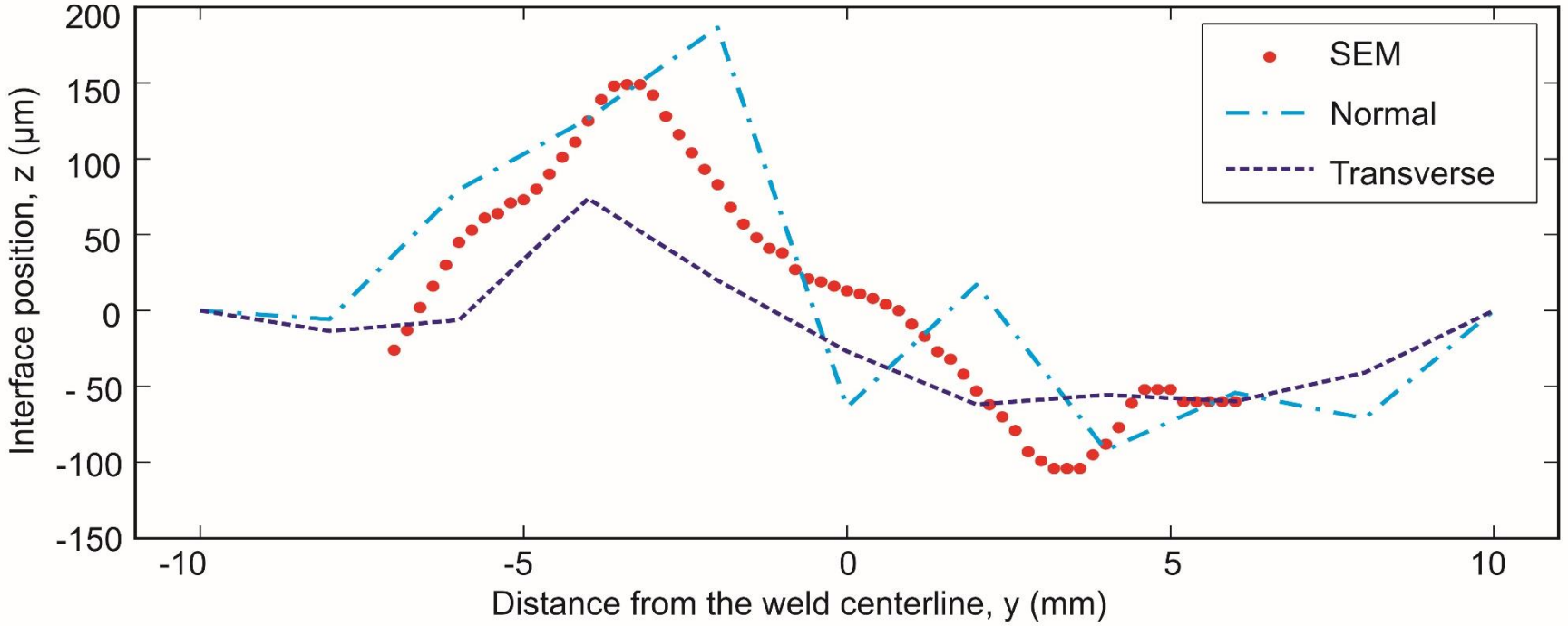
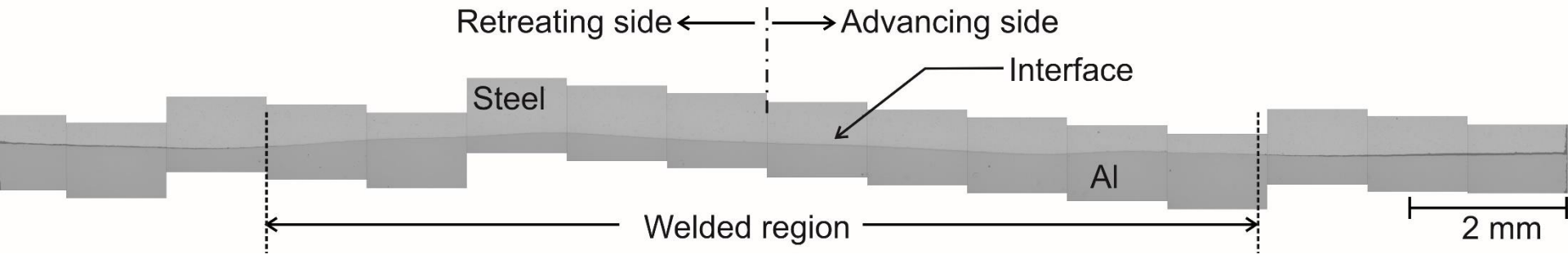

Sampling points and materials used for residual stress measurements

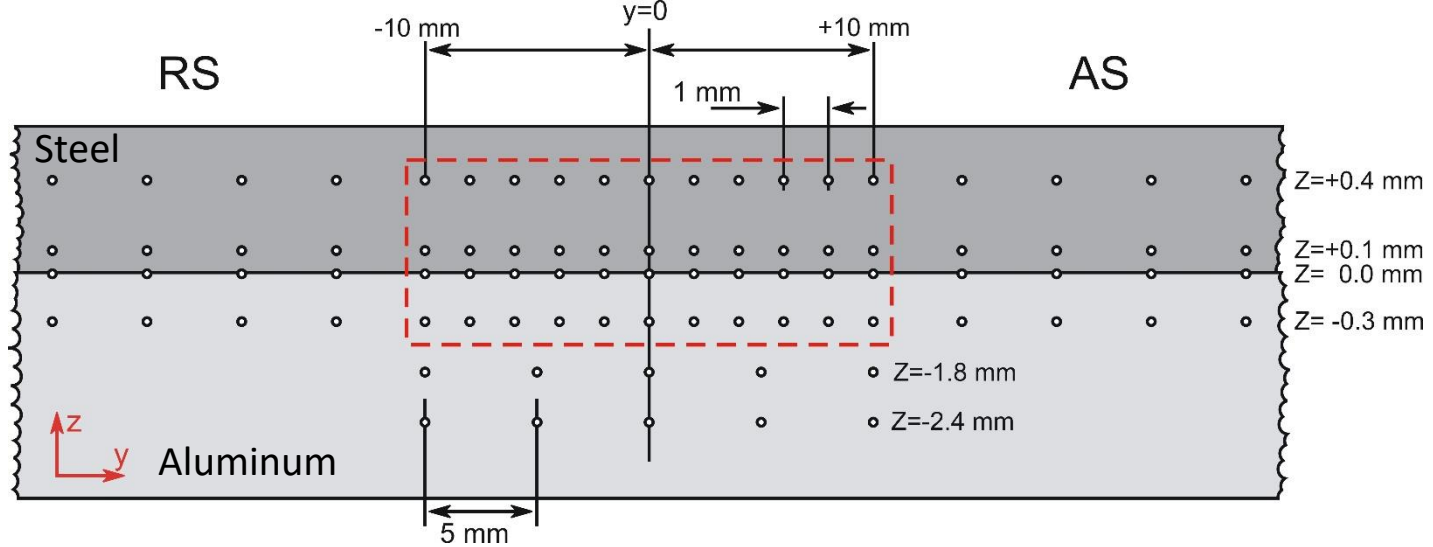

Transverse cross section showing the measurement points

Parent materials of DP600 and Al1050+TiB2 alloy were used

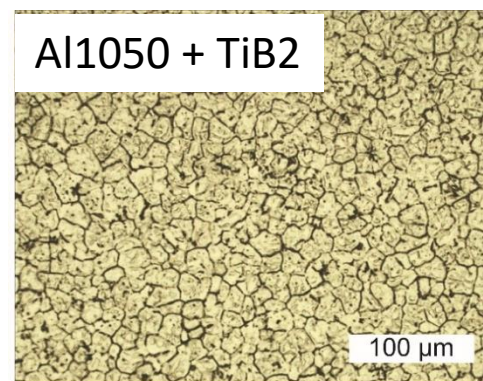
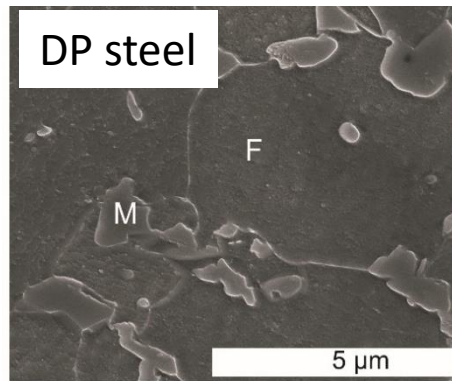

Microstructure changes and FWHM of diffraction peaks

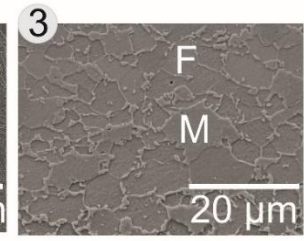
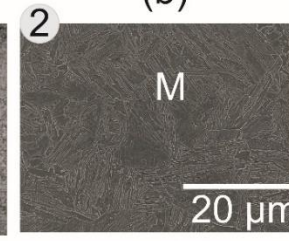
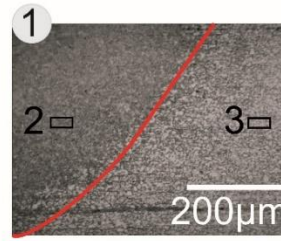
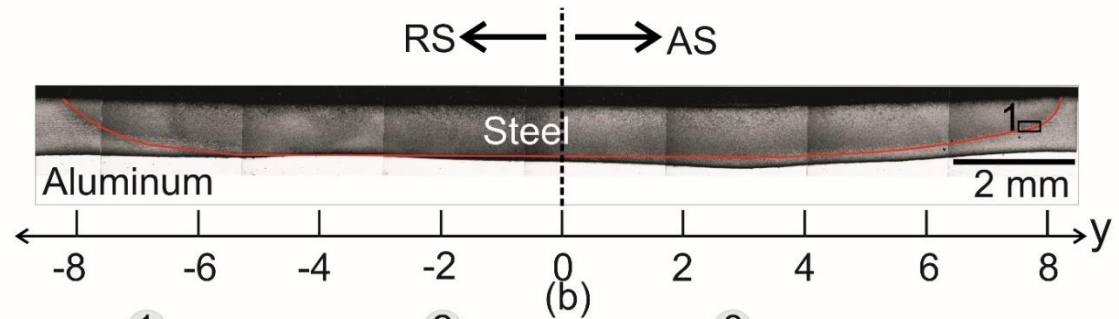
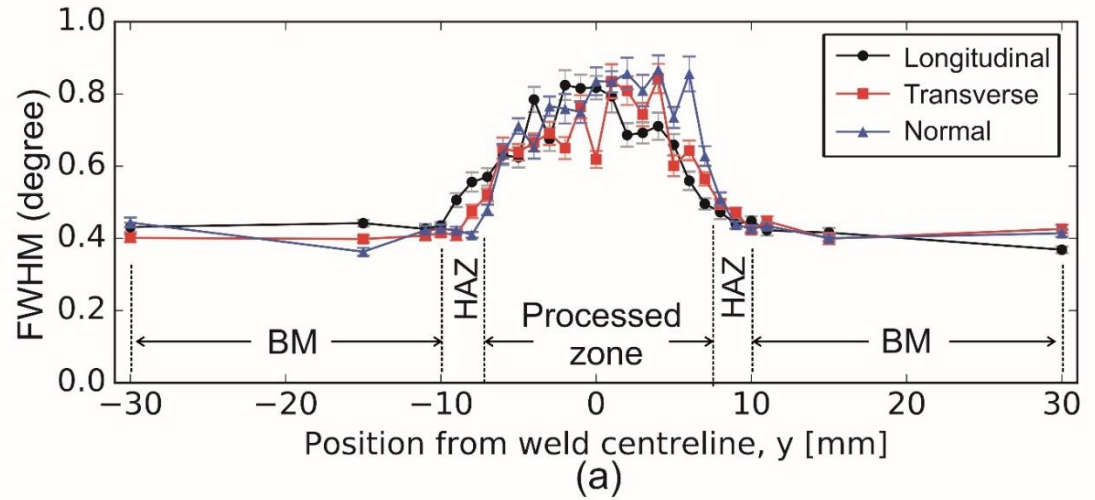
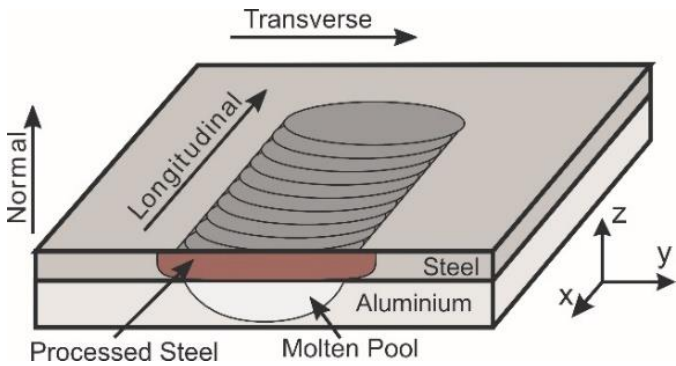

Residual stresses in steel along Z = +0.4

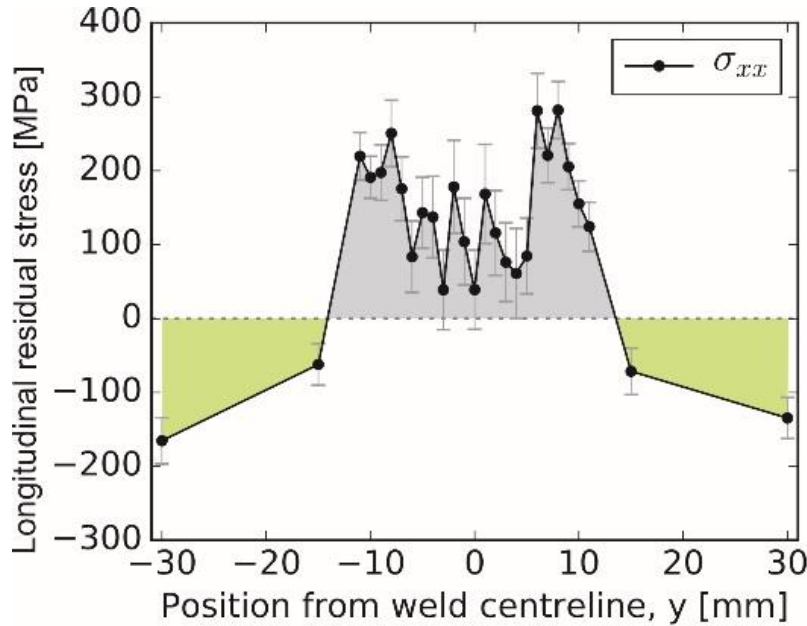

Longitudinal

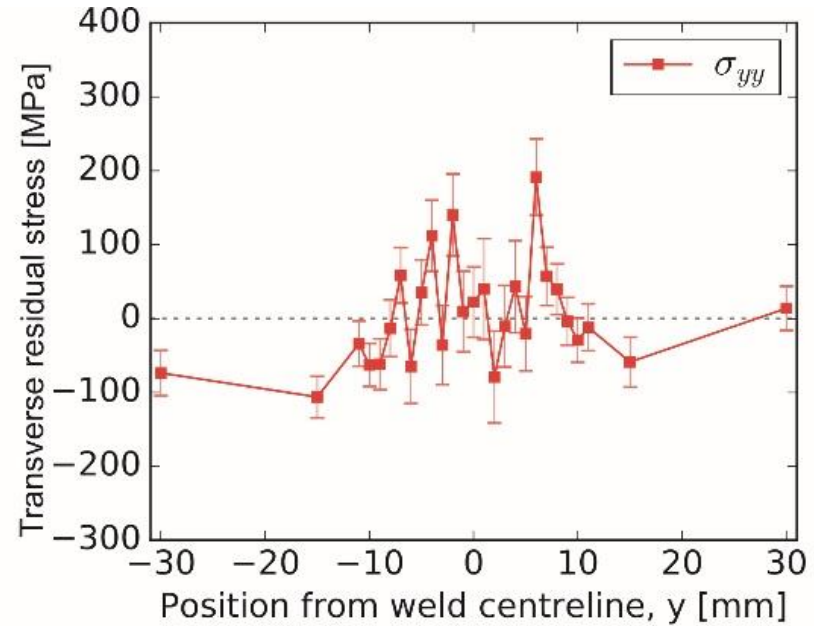

Transverse

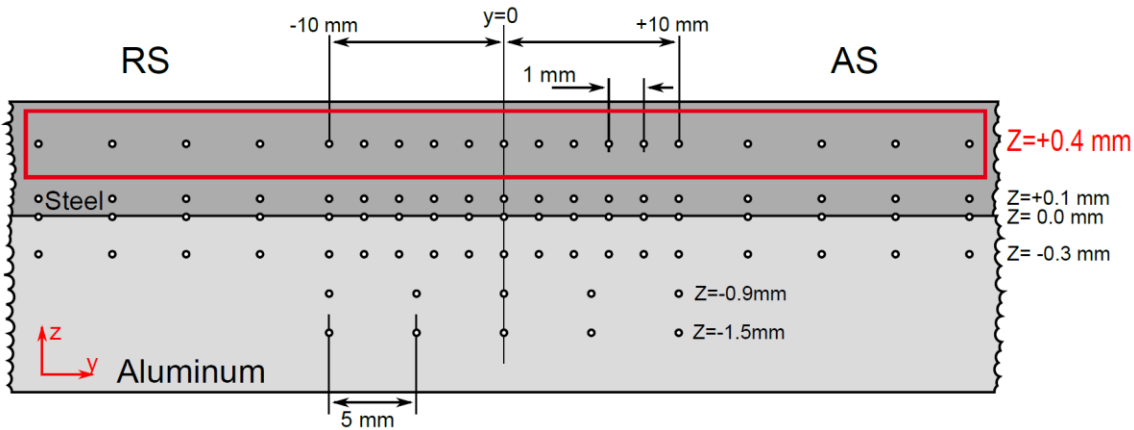

Negative y – Retreating Side (RS)

Positive y – Advancing Side (AS)

Residual stresses in Aluminum alloy Z = -0.3

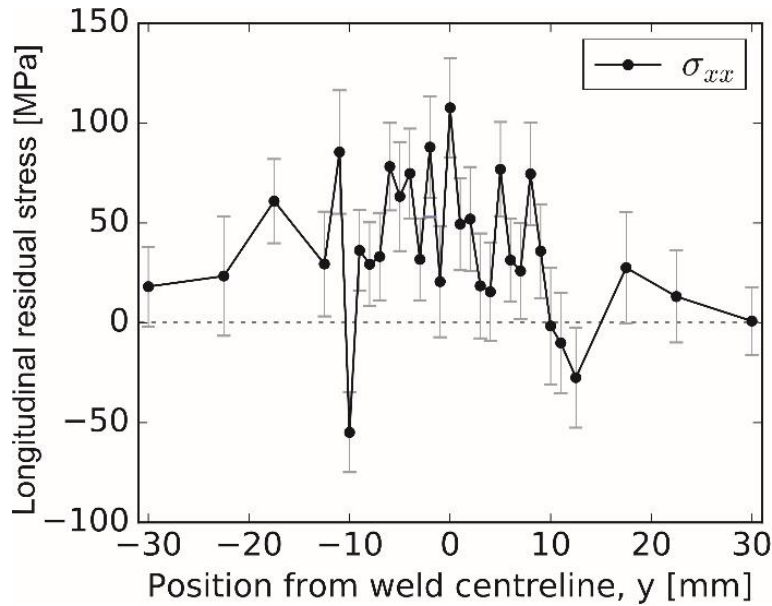

Longitudinal

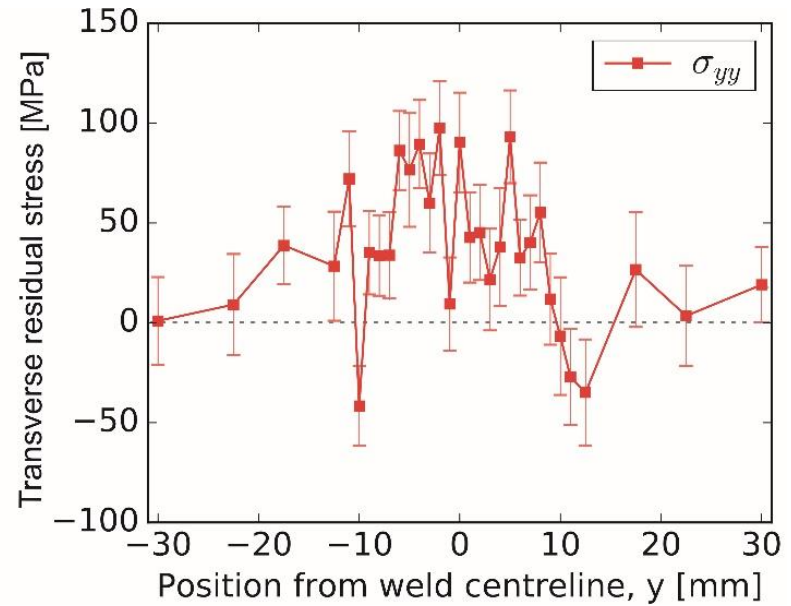

Transverse

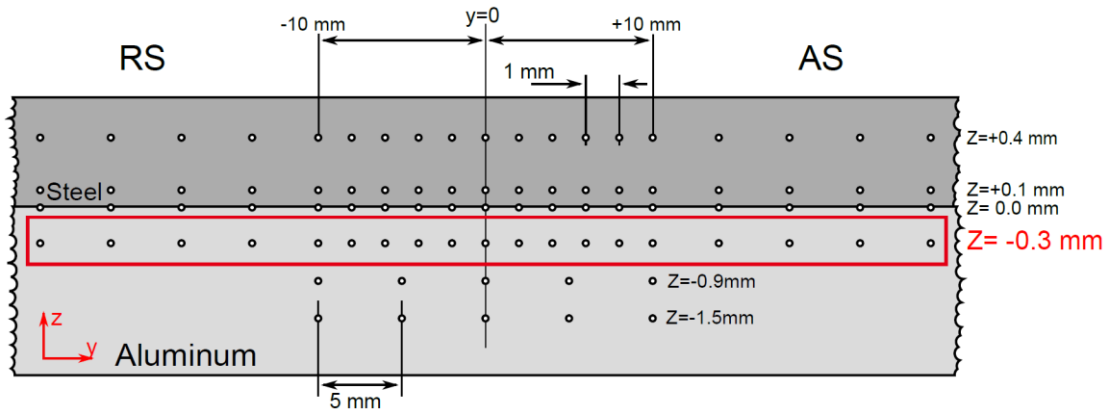

Negative y – Retreating Side (RS)
 Positive y – Advancing Side (AS)

Origin of longitudinal residual stresses in steel at the interface

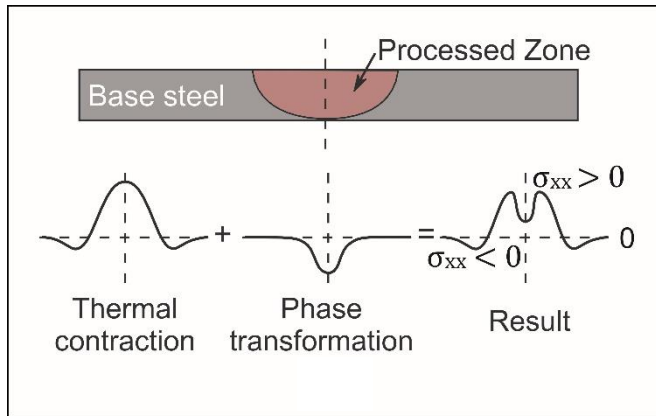

Origin similar to a FSW like condition

+

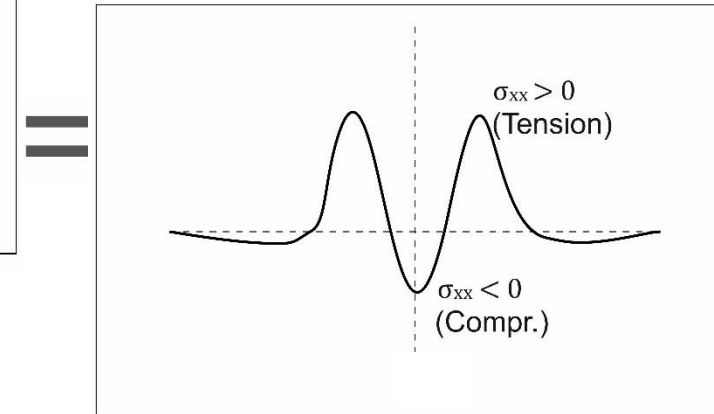
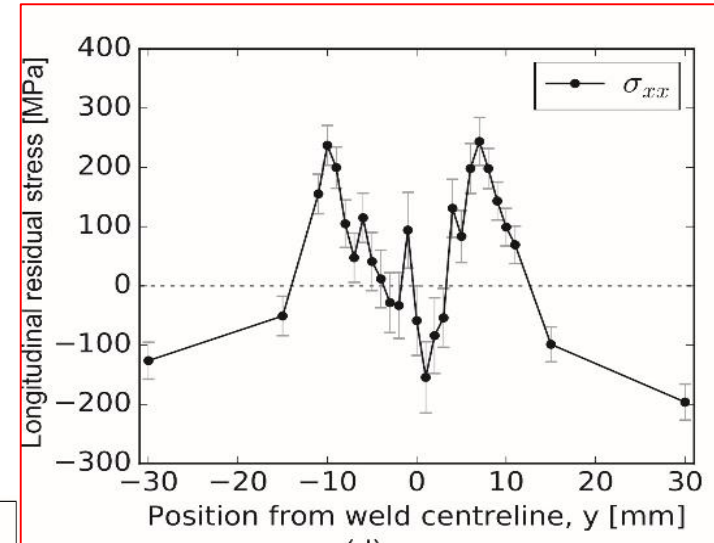
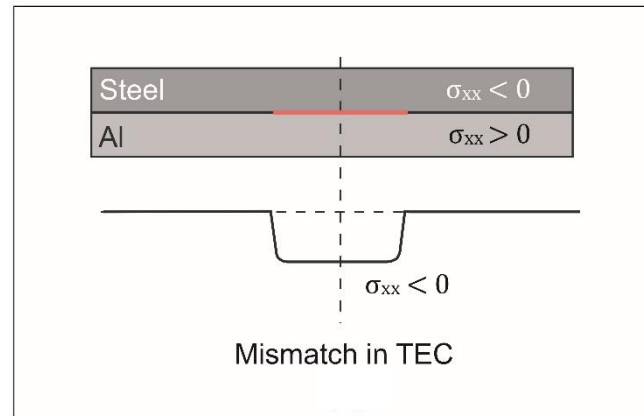

[FSW: Friction Stir welding, CTE: Coefficient of thermal expansion]

Origin of longitudinal residual stresses in aluminum at the interface

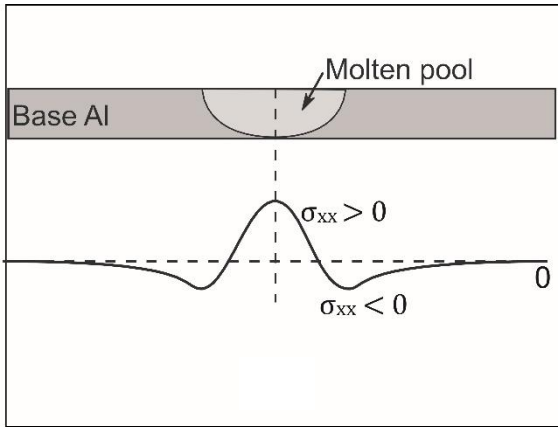

Origin similar to an arc welding +

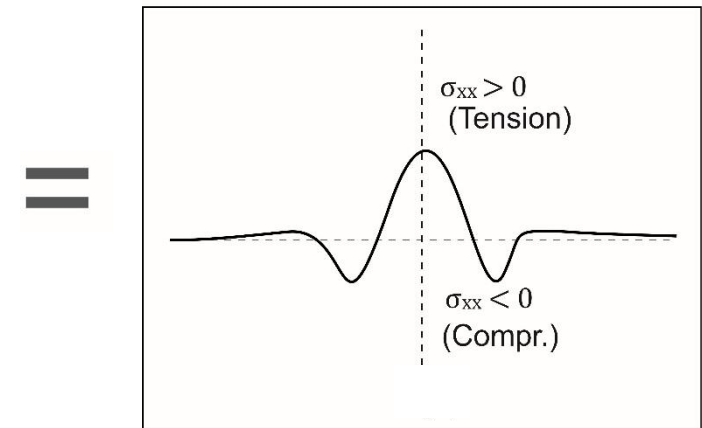
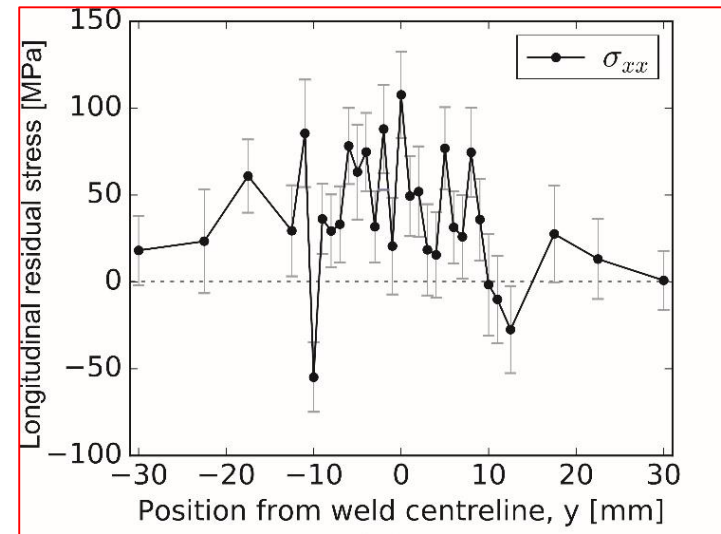
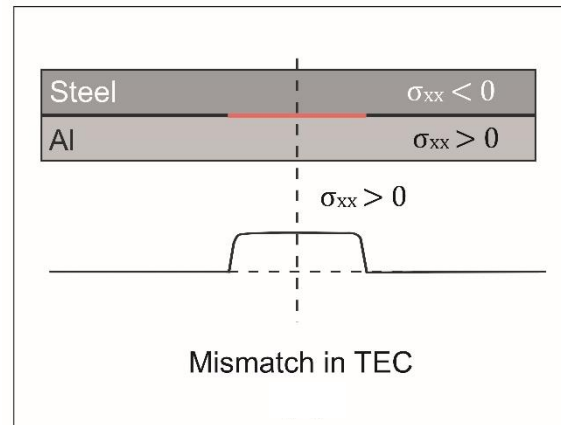

[CTE: Coefficient of thermal expansion]

Contribution of residual stresses due to the mismatch of CTE

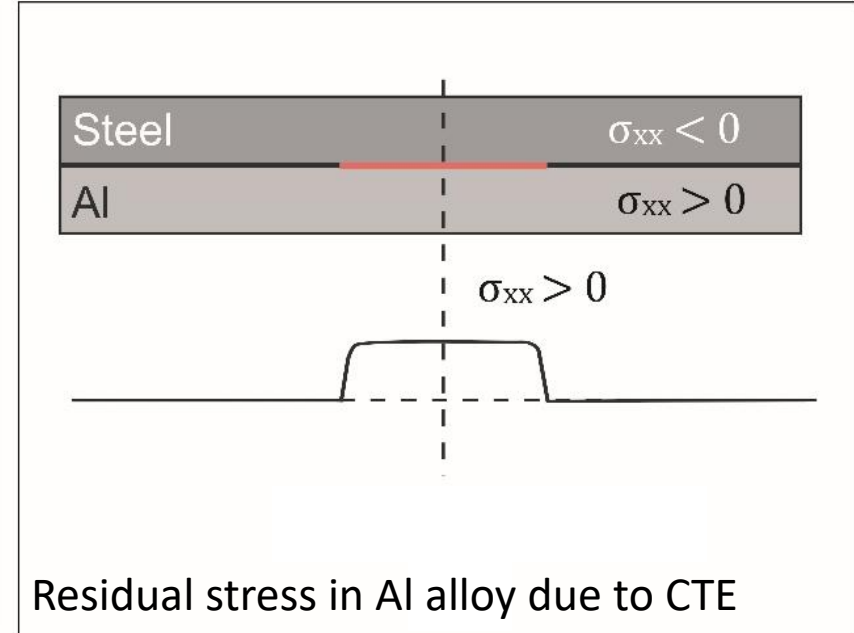
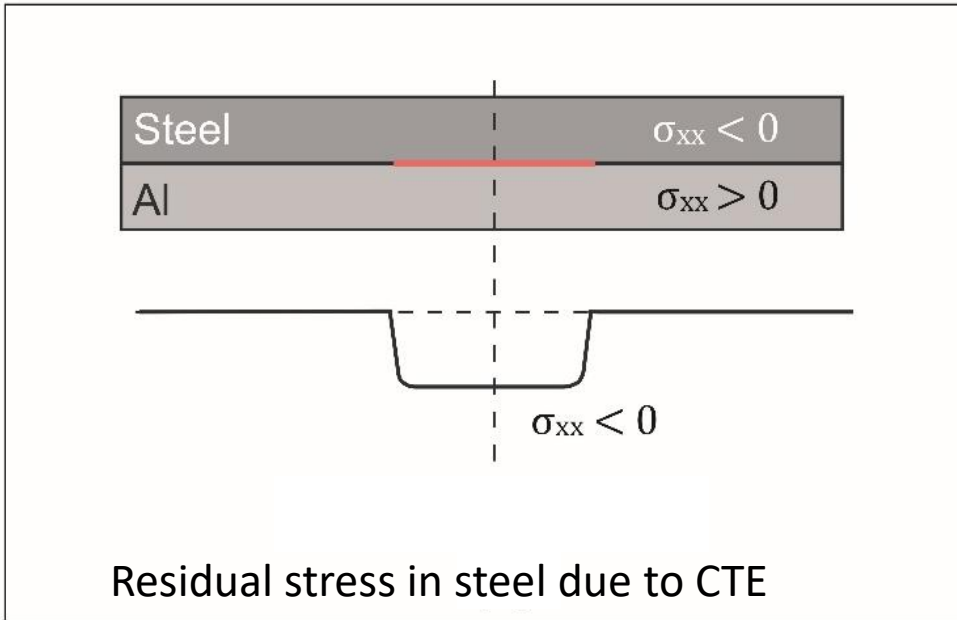

- CTE causes 23 $\mu\text{strain}/^\circ\text{C}$ for Al alloy and 14 $\mu\text{strain}/^\circ\text{C}$ for steel
 - After they bonded together, a constraint of identical deformation presents at the interface
 - Thus, the true deformation at the interface has a value in between that of Al and steel, compared to value of free contraction
 - So, steel contracts more than the case of free boundary \rightarrow Compressive residual stresses
 - And Al results with tensile residual stresses
- [CTE: Coefficient of thermal expansion]

[N. Jimenez-Mena, T. Sapanathan *et al.*, 2019, Journal of Materials Processing Technology]

Influence of hot tear on the residual stresses

- Investigated the residual stresses for welds with the presence of hot tear
- Parent material of AA6061-T6 and DP600 steel were used
- Stainless steel and brass backing plates were used to get the welds with different amount of hot tear

Welding cases	Backing plate	Welding speed
B200	Brass	200
B400	Brass	400
SS200	Stainless steel	200
SS400	Stainless steel	400

Measurements of neutron diffraction

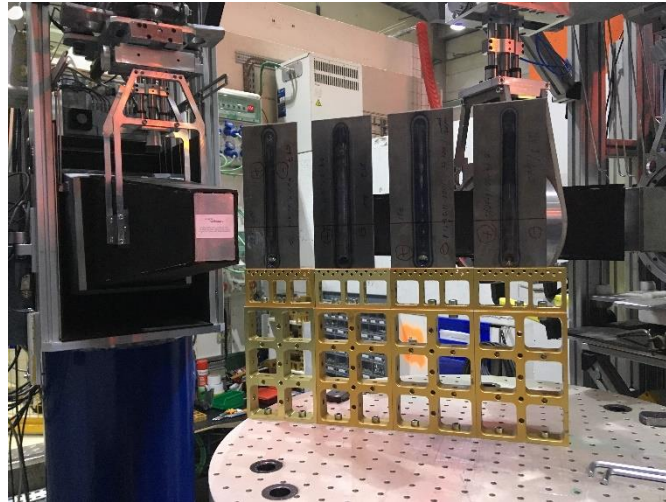

4 samples mounted on the Hex-support table

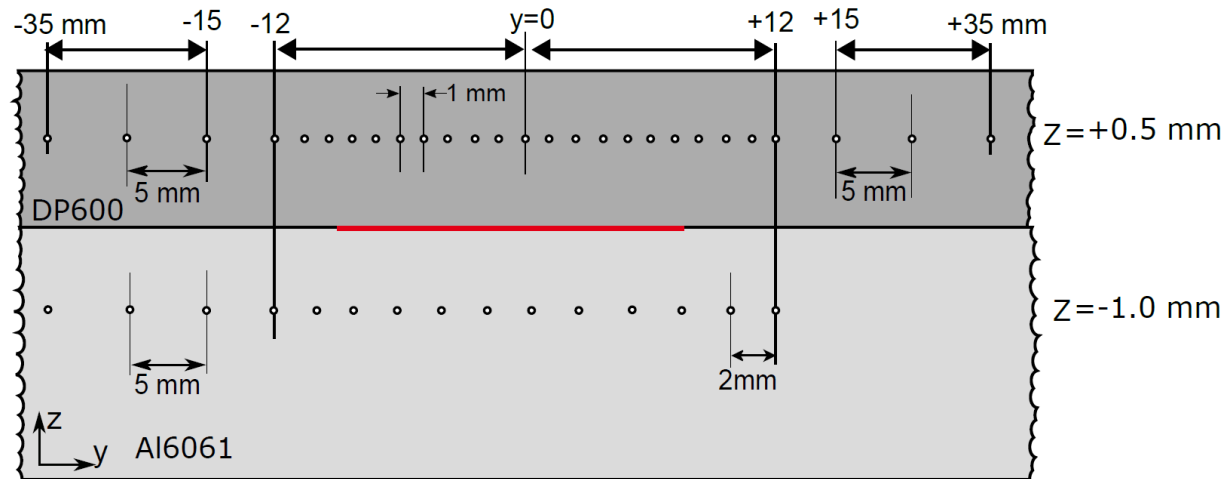

Transverse cross section showing the measurement points

Measurements parameters to avoid pseudo strain

- Nominal Gauge volume (NGV) 0.6 mm × 0.6 mm × 2 mm
- Actual gauge volume is much bigger and having the diagonal lengths of about 1.4 mm
- Since we use 0.9 mm thick steel, sample oscillation function was used
- 0.6 mm/min oscillation speed covering ~ 1.5mm of amplitude

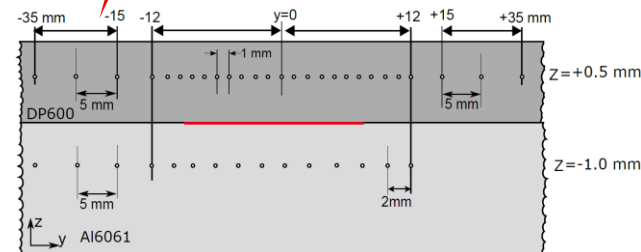
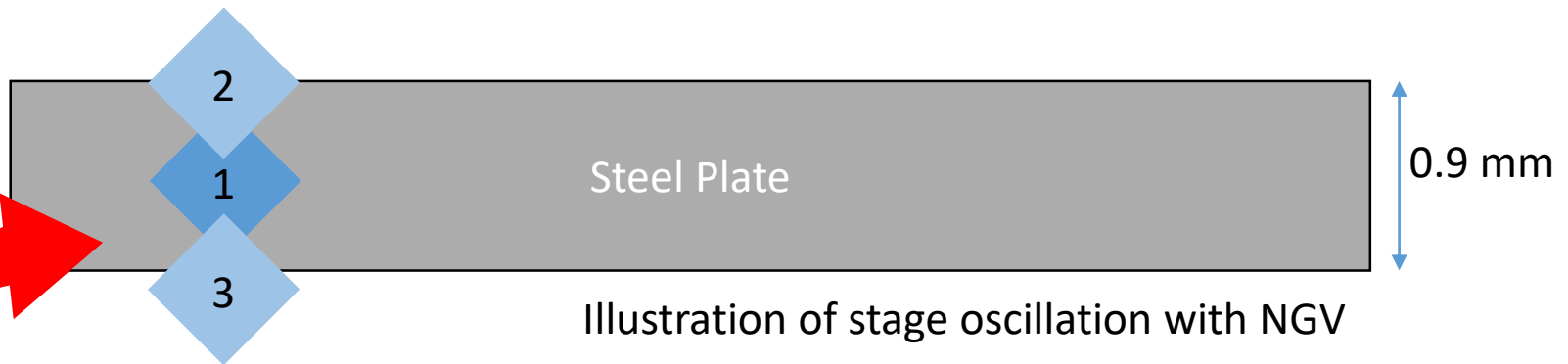

Transverse cross section showing the measurement points

Longitudinal Residual stresses in steel

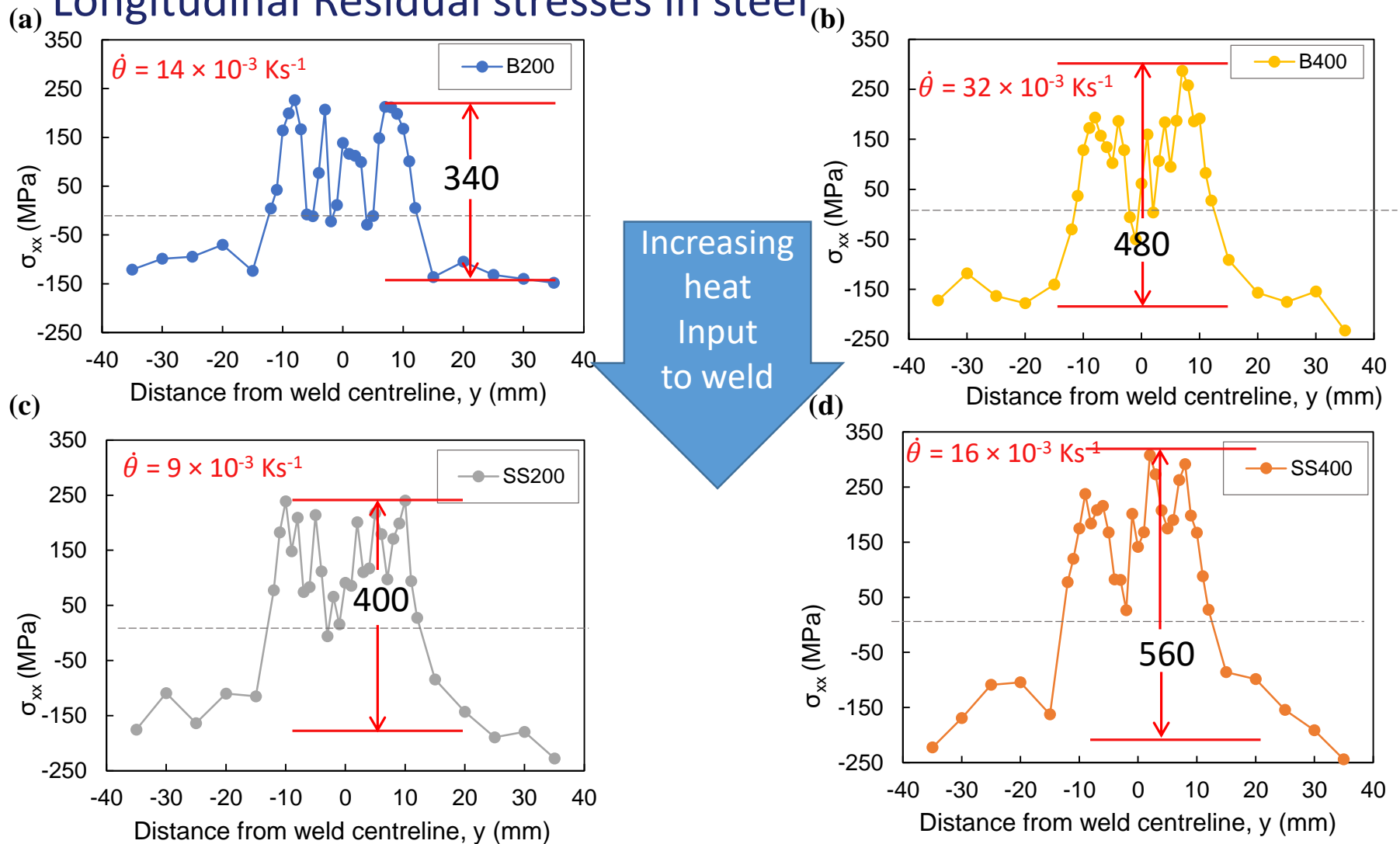

Similar to FSW, σ_{xx} increases with transverse speed due to low heat input for short duration

Transverse residual stresses in steel

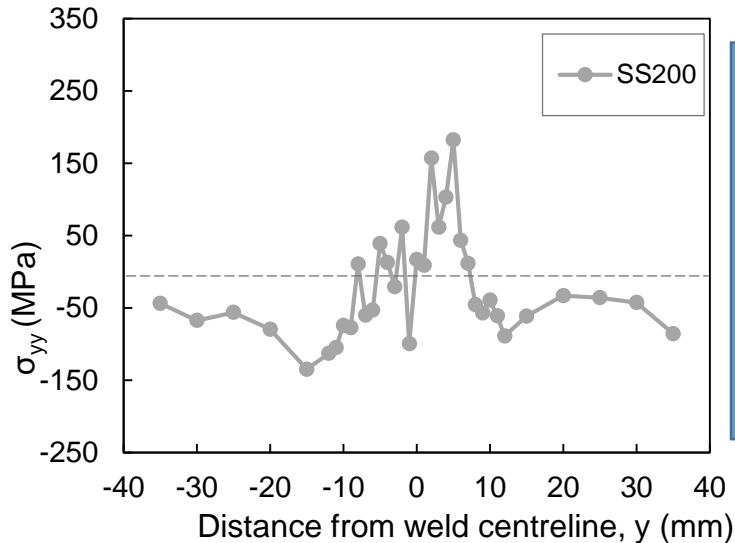
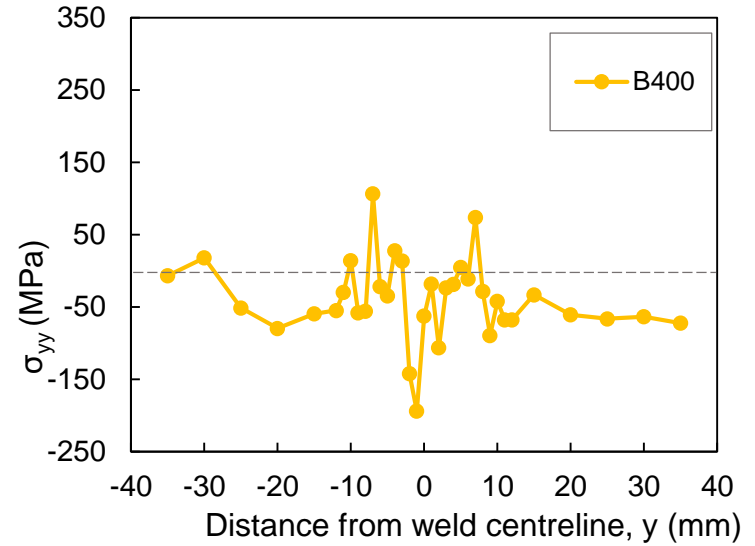
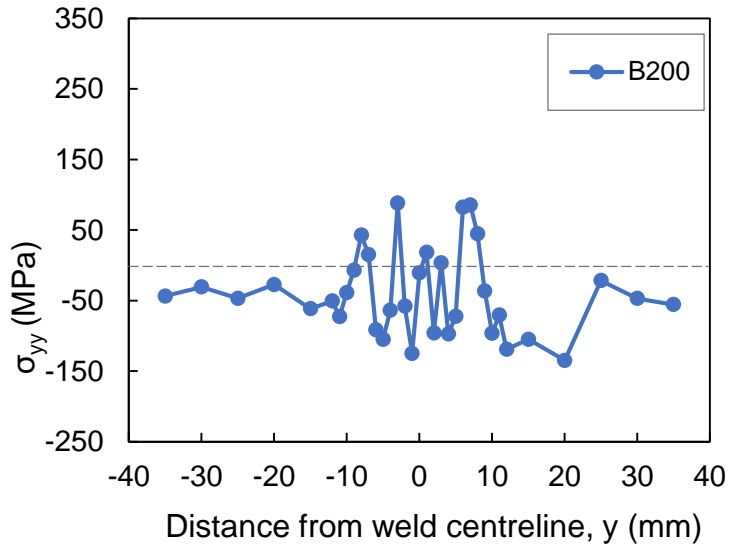

σ_{yy} show slight increase of tensile stresses in the middle of the weld for the SS backing plate

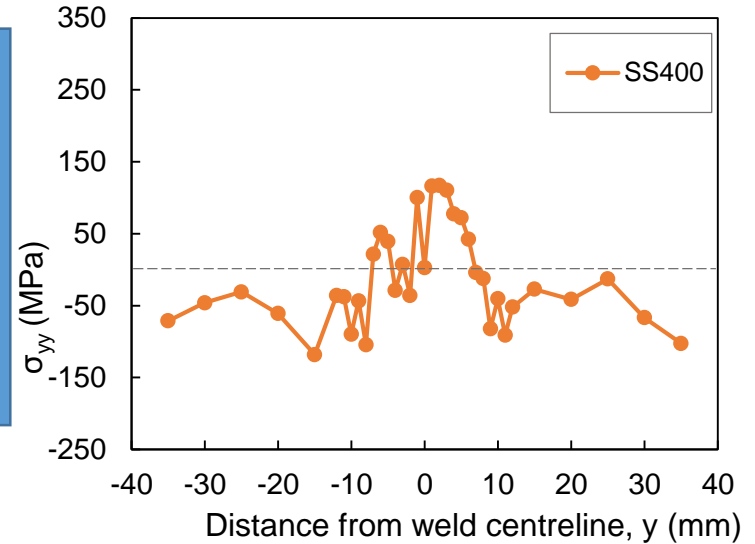

Longitudinal residual strains and stresses in steel

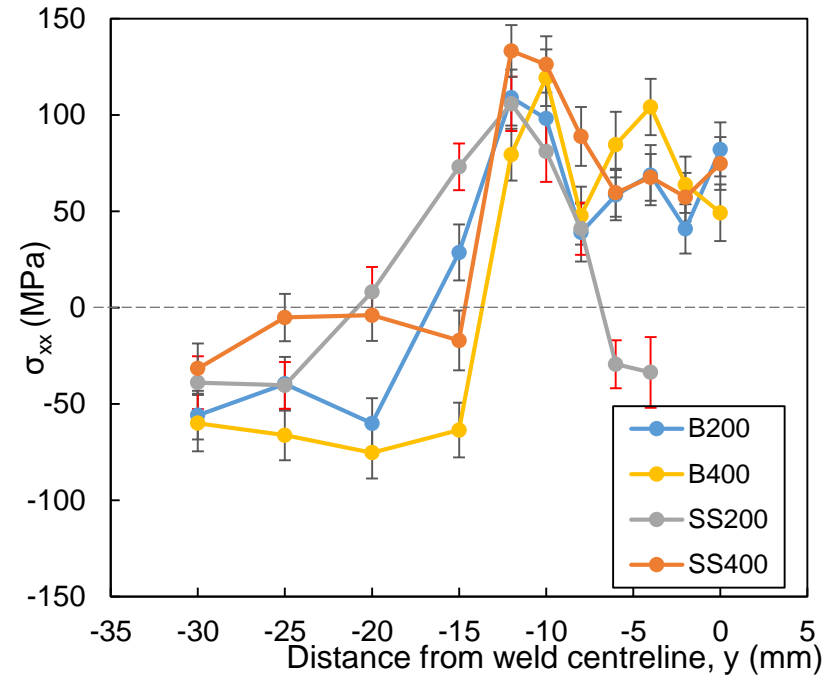
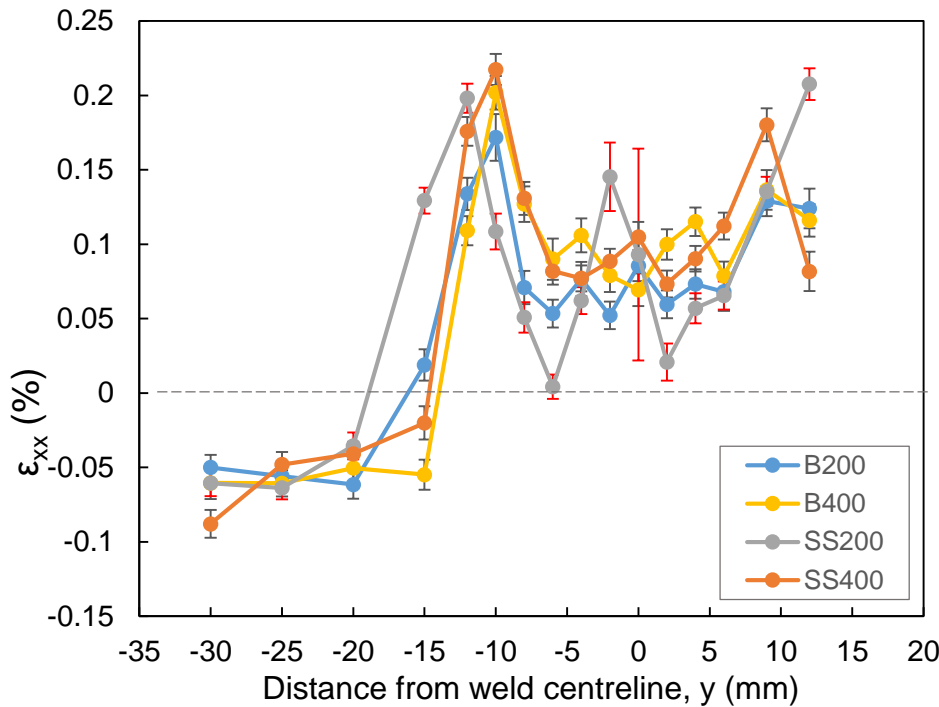

- The strains were checked passing the center line (y=0) of the weld
- Due to symmetry, the other components measured until the middle of the weld
- σ_{xx} in the Aluminum for SS backing plate shows large fluctuation

Transverse and Normal 2θ angle comparison for stainless steel backing plate samples

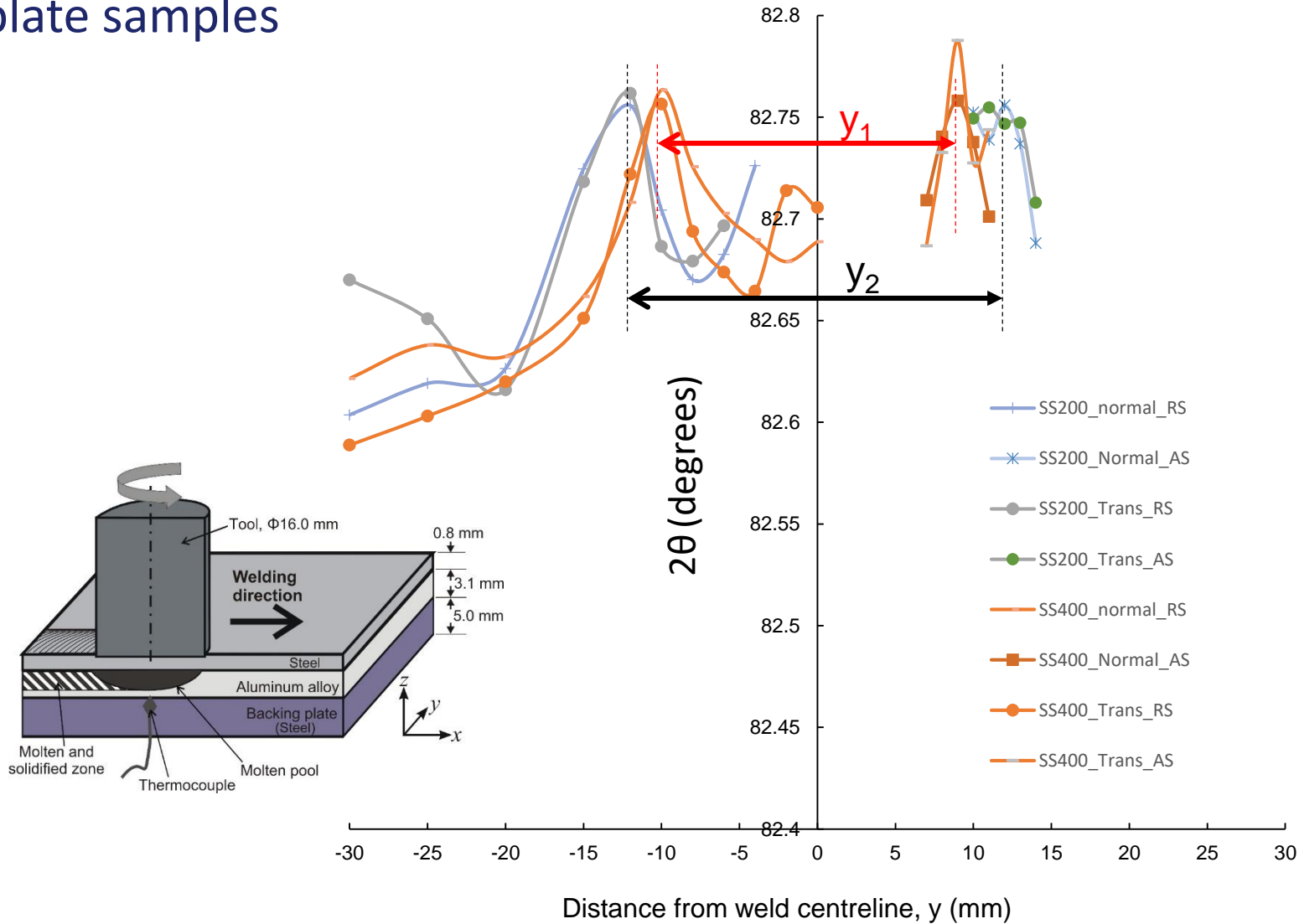

Presence of hot tear on the residual stress

- After the measurement, when cutting the sample, the welds performed with stainless steel backing plate failed completely

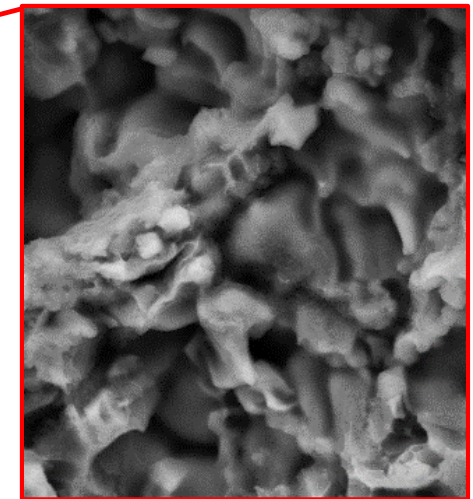
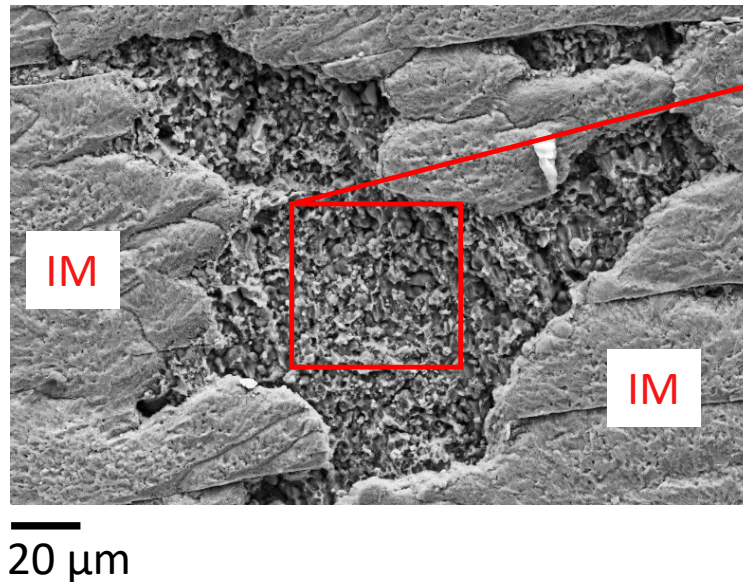

Region of hot tears
under the IM zones

- ✓ Large residual stresses resulting from the processing conditions still remain present in the welds with hot tears
- ✓ Those welds fail due to the stress release during cutting

Presence of hot tear on the residual stress

- After the measurement, the samples with brass backing plate still remain intact

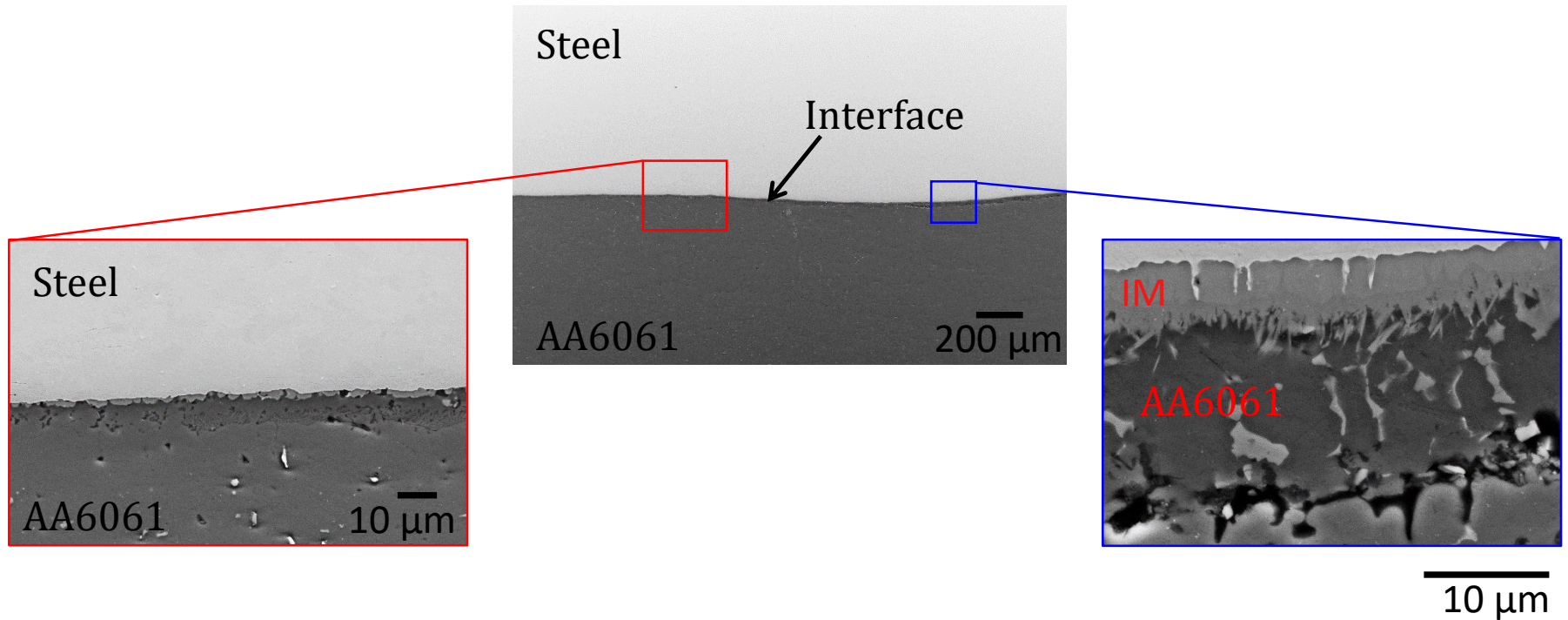

- ✓ Brass backing plate samples also shows small hot tear
- ✓ Amount of hot tear does not show a direct correlation with the residual stresses

Conclusions

- Upper steel plate shows an overall “M” shape residual stress distribution while lower aluminum reveals “W” shape at the interface. This mirror effect mainly presents due to the mismatch in CTE.
- Under same welding condition, brass backing plate shows lower residual stresses compared to the one welded with stainless steel backing plate.
- Residual stresses increase in the FMB welds with the Increase of transverse speed, due to high cooling rate.
- On the aluminum side, the distance between the peaks are wider for the welds performed with slower speed, due to large molten pool size.
- Residual stress distribution does not show direct correlation with the presence of hot tear.

Contributors involved in the work presented today.....



Norberto
Jimenez Mena

Aude
Simar

Pascal
Jacques

Jean-Marie
Drezet

Sandra
Cabeza

Thilo
Pirling

I thank international Neutron Source at Institut Laue-Langevin (ILL) for the provision of beam times at SALSA instrument (Proposal No. 1-02-212 & 1-02-245)



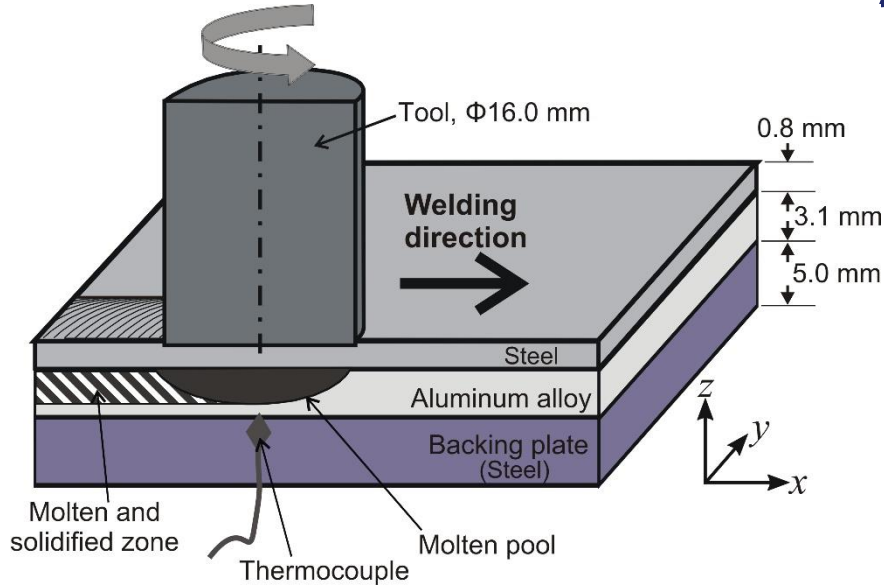

Friction melt bonding

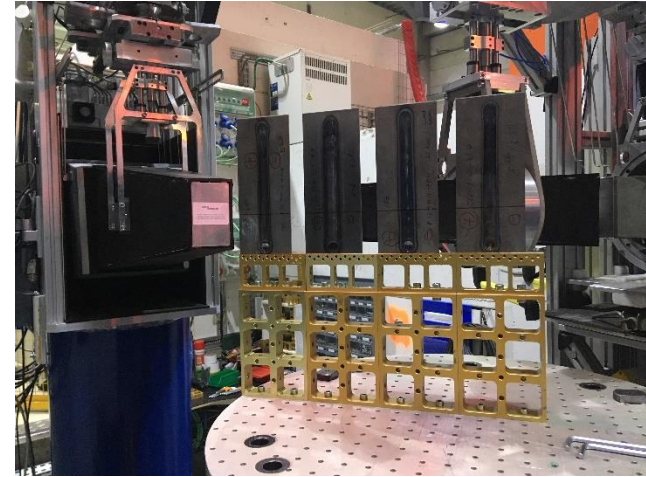

Residual stress measurement

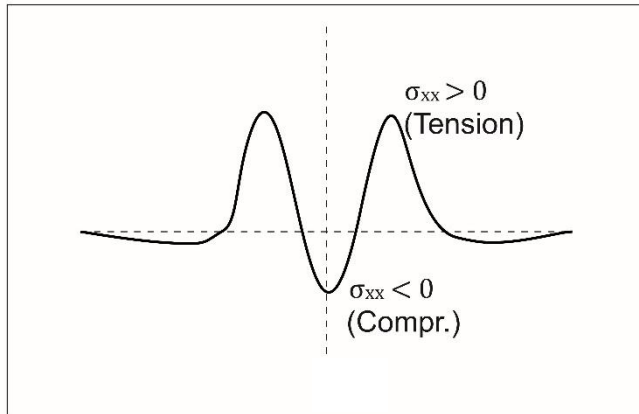

Longitudinal residual stress in steel

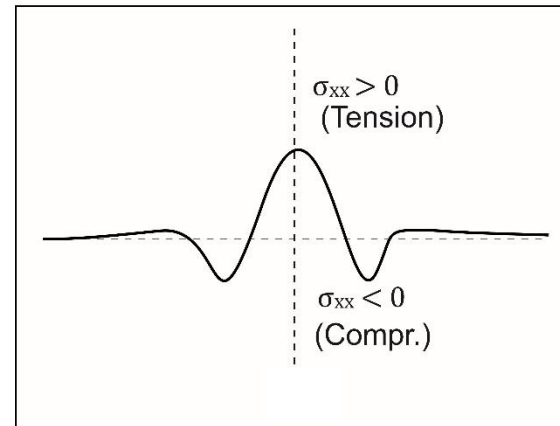

Longitudinal residual stress in Aluminum