

P. P. Deen, D. Noferini, F. Moreira, L. Loaiza, G. Fabrèges.
W. Lohstroh, S. Longeville.

CSPEC is the cold chopper spectrometer of the ESS and is expected to come online with beam on target (BOT) which has recently been set to March 2023. The CSPEC current hot commissioning date (TG5) is December 2022 providing some margin with respect to BOT. In this STAP report we provide an overview of the status of the main components. Comments and requests from the previous STAP report are provided within the report.

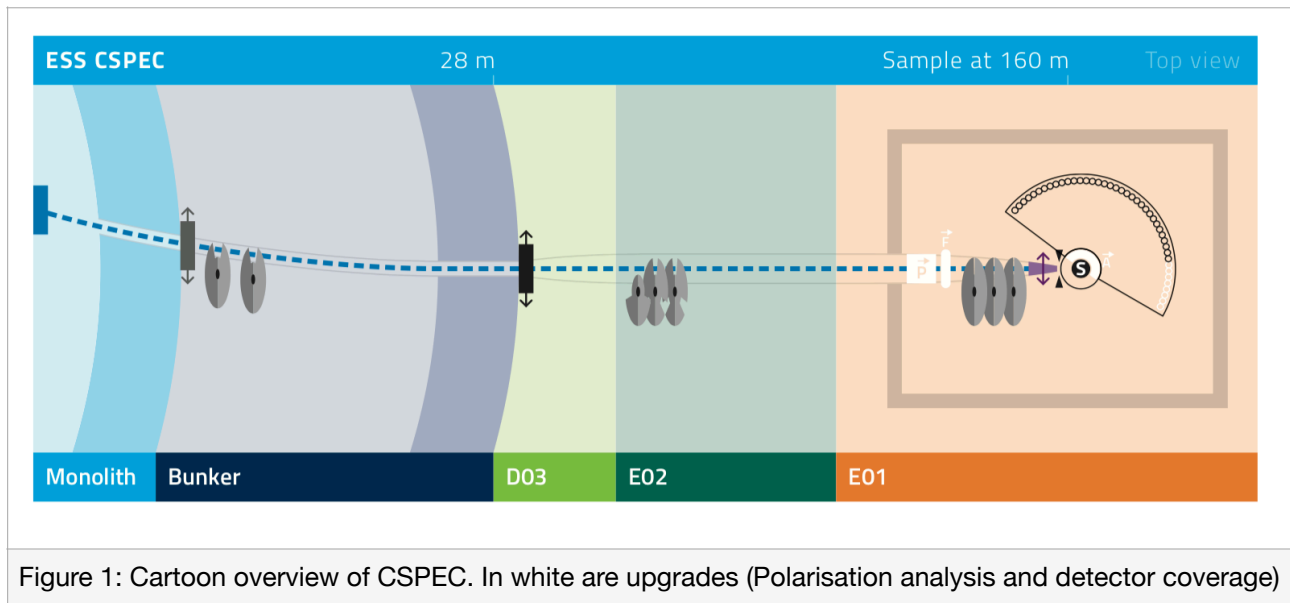

Figure 1: Cartoon overview of CSPEC. In white are upgrades (Polarisation analysis and detector coverage)

Guides.

To date we have manufactured approximately 84 m of guides (out of bunker). The last sections to be produced have not yet been tested for conformity by neutron reflectivity since the FRM2 reactor has not been operational. We are looking for other alternatives but these have not yet been found. We do not estimate that this will impact TG5.

The guide piece closest to the moderator, the neutron beam optics assembly (NBOA) with a Cu substrate, is under manufacture but with a slight delay due to COVID.

BGG Bridge beam guide (guide within the bunker wall) is also a Cu substrate guide. Also under manufacture with a slight delay due to COVID.

Guides housing and alignment.

The preliminary design of the guide vacuum housing and alignment features have been performed by the engineering team at TUM (L. Loaiza, P. Link) with the detailed design outsourced. A final design prototype vacuum housing can be seen in Figure 2. Alignment features and guide installation within the guide housing can be seen on Figures 2(a-c). An Al vacuum window (0.5 mm thick) is shown in Figure 2(d). The optics group at TUM have inspected the pilot vacuum housing. The vacuum housing deformed less than $< 20 \mu\text{m}$ under vacuum and showed a repeatability of the kinematic mount $< 20 \mu\text{m}$. Installation tools have been developed and tested. Vacuum requirements are complied with although some seals had to be changed. Alignment methods have been checked. The successful prototype tests allow us to manufacture the complete out of bunker vacuum housing. The in-bunker vacuum housings have slightly different requirements. We are currently negotiating for their detailed design and manufacturing.



Figure 2: 4 m long guide housing ready for alignment and deformation checks.

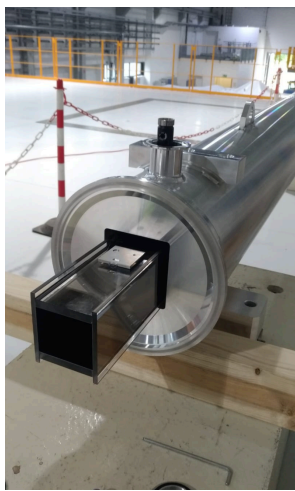

Figure 3(a): Guide installation in vacuum housing.



Figure 3(b): Guide alignment feature for the housing.

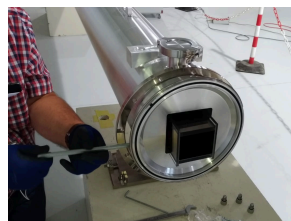

Figure 3(c): Further guide alignment.



Figure 3(d): Al window at end of guide housing.

Instrument shutter

The CSPEC light shutter is positioned directly after the bunker wall at 28.5 m from the moderator. Prior to the shutter is an Al window that separates the bunker environment from the rest of the instrument. At this position CSPEC will also place a neutron flux monitor. A 33 mm gap between Al windows, and a 40 mm gap between neutron guide pieces, is provided to place these two components. The small gap size will limit any flux losses. The light shutter is designed to enable access to the PS chopper area and the sample environment space.

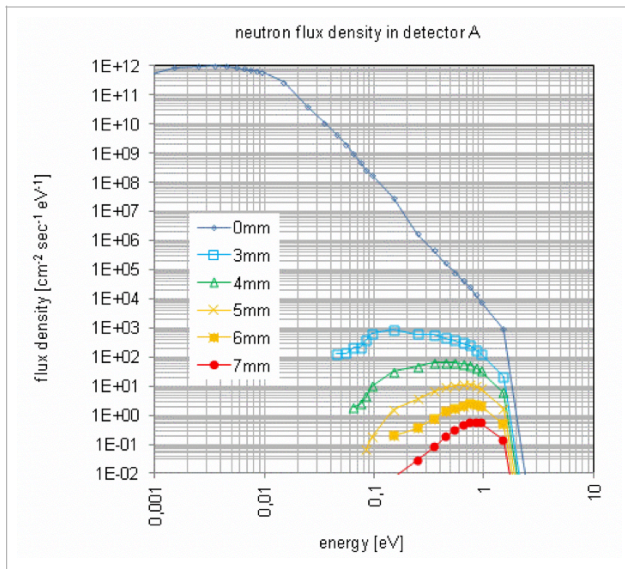

Figure 4(a): Neutron flux density in a detector after a varying thickness of B4C sheets at 28.5 m.

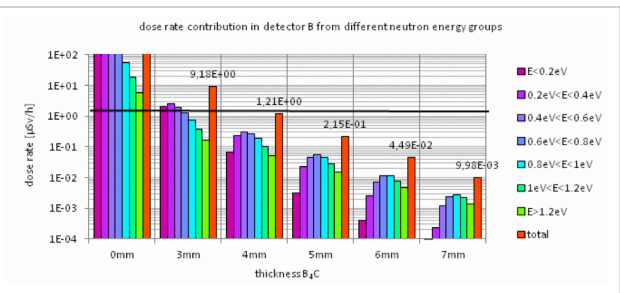

Figure 4(b): Dose rate contribution directly after the instrument shutter from different neutron energy groups. The continuous line shows the 1.5 µSv/hr radiation safety requirement.

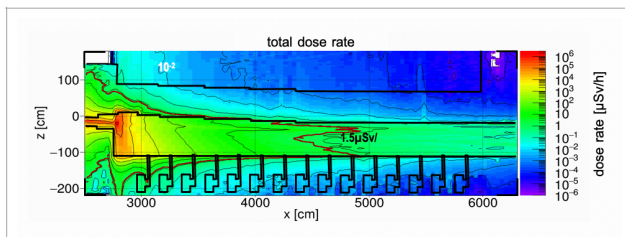

Figure 5(a): Total dose rate distribution between bunker wall and 65 m from moderator for the closed shutter (6 mm B4C). The red line is the 1.5µSv/h border.

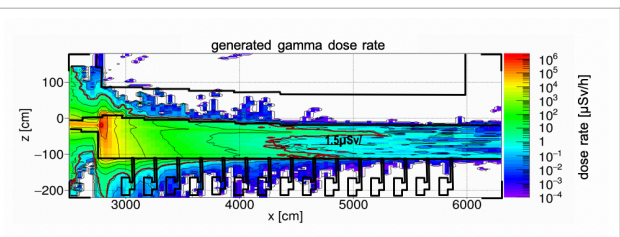

Figure 5(b): Gamma dose rate distribution between bunker wall and 65 m from the moderator for the closed shutter (6 mm B4C). The red line is the 1.5µSv/h border.

Neutronics MCNPX calculations of the CSPEC guide and components show that the thickness of the shutter sheet, made from B₄C, must be 5 mm or more in order to reach the 1.5 µSv/hr radiation requirement for access to a non-controlled area, see Figure 5(a). This holds for a B₄C density of 2.4g/cm³. If this density cannot be reached the thickness has to be increased by the corresponding factor. The assumptions of the calculations include 5 MW operating power with a 2 GeV proton beam. All the choppers are in the open position.

The 1.5µSv/h neutron dose rate border inside the shielding is reached at 50 m, from the moderator, with a closed thermal neutron shutter (6mm B₄C.). Hence the dose rate inside the PS chopper pit, at 105.6 m, is below 1.0 µSv/h. Further gamma dose calculations show that no additional gamma shielding is necessary behind the thermal neutron shutter, see Figure 5(b).

These simulations also show that fast and epithermal neutrons (E > 1 eV) are limited to the bunker and are not transported to the sample position.

The instrument shutter design must incorporate an extractable monitor. The preliminary shutter design, see Figure 6, contains both the instrument shutter and the monitor that can be placed independent from each other. The monitor in the image is an LND neutron beam fission monitor. The final decision on monitors technology has not yet been made. Design by L. Loaiza (TUM). The shutter will be manufactured at FRM2.

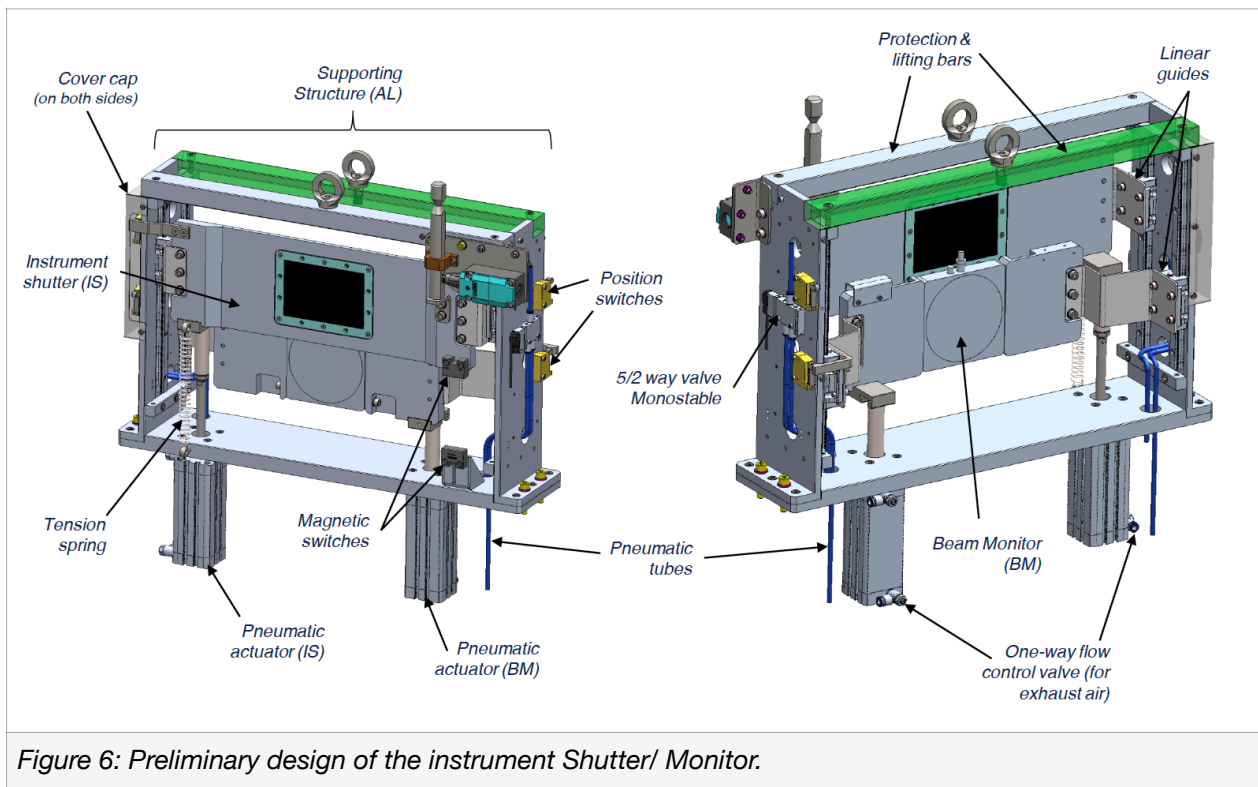

Figure 6: Preliminary design of the instrument Shutter/ Monitor.

Monitors

Space for beam monitors (BM) are provided at the following positions:

BM0 ~ 6 m from moderator, in bunker

BM1 ~28 m from moderator, directly after bunker wall

BM2 ~105.6 m from moderator, directly after PS chopper

BM3 ~158.8 m from moderator, after M chopper and at the intersection with the exchangeable guide

BM4 after the sample position.

BM0 is a requirement of the ESS and will be used to obtain information on the moderator. BM1 and BM2 will be integrated in an automatic mechanism, designed by the CSPEC team, see Figure 6, to lift them, remove them from the beam (e.g. during experiments), and drop them to the beam position when needed. BM3 will be used for beam diagnostic and will always be in place during operations, including during the experiments for normalisation purposes. BM4 will be mainly used to monitor the transmitted beam and put in place and removed on need by hand.

A Call for Tender Verification (CTV) document for the monitors with the detailed specifications is currently under preparation.

CSPEC received a first offer draft from the monitor group for the development, acquisition and installation of the CSPEC monitors. The technology for each BM is not defined and several details remain to be discussed. The calculated cost envelope is 30k EUR per monitor, including hardware and labour costs, and includes completion of cold commissioning. Any excess costs will be covered by NSS, all cost savings will be passed back to the instrument.

The CSPEC team is exploring possible alternatives to the offer from the common project, especially regarding BM3 and BM4. For BM4 a neutron camera could be a suitable and fairly inexpensive solution.

Shielding

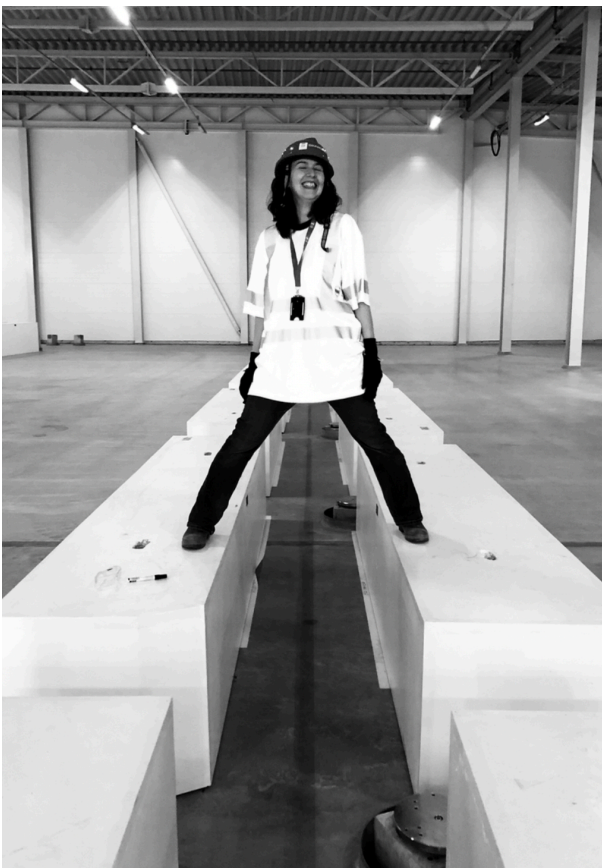

Figure 7(left): Lower blocks of the primary spectrometer shielding in E02.



Figure 7(right): Pilot cast of the upper part of the primary spectrometer shielding.

Primary spectrometer shielding

In collaboration with the common shielding project the CSPEC lower shielding blocks have been installed in E02-2, see Figure 7 (left). The TG3 (detailed design) of the upper shielding blocks has been approved and pilots have been casted and approved, see Figure 7 (right). Full manufacturing of the complete guide shielding is in progress.

Secondary spectrometer shielding

MCNPX simulations are on going. These have been delayed since the simulation effort focussed on the primary spectrometer shielding. We expect to finalise the shielding calculations for the cave and the background requirement by December 2020 with a detailed secondary spectrometer shielding design by April 2021.

Detectors

CSPEC - ESS Contract signed

The MG detector budget, i.e. 18 Detector modules at 100% front-end electronics grid coverage (vessels excluded) is set to the value of € 3 914 420. Access to the detector tank for detector installation to be granted in July 2022 until Dec 2022. The time available during that period will be decided in collaboration with the CSPEC team upon consideration of the CSPEC installation timeline. Within the contract the 1st Detector assembly (vessel) will be completed April 2021.

Work is on-going to perform a MG detector tests on LET. These tests are performed on a detector that is limited in height (1 m) but with both side and long blades coated in B10. As such the spurious quasielastic scattering observed in previous tests (SEQUOIA tests) should be negligible. Tests are expected to take place in November 2020.

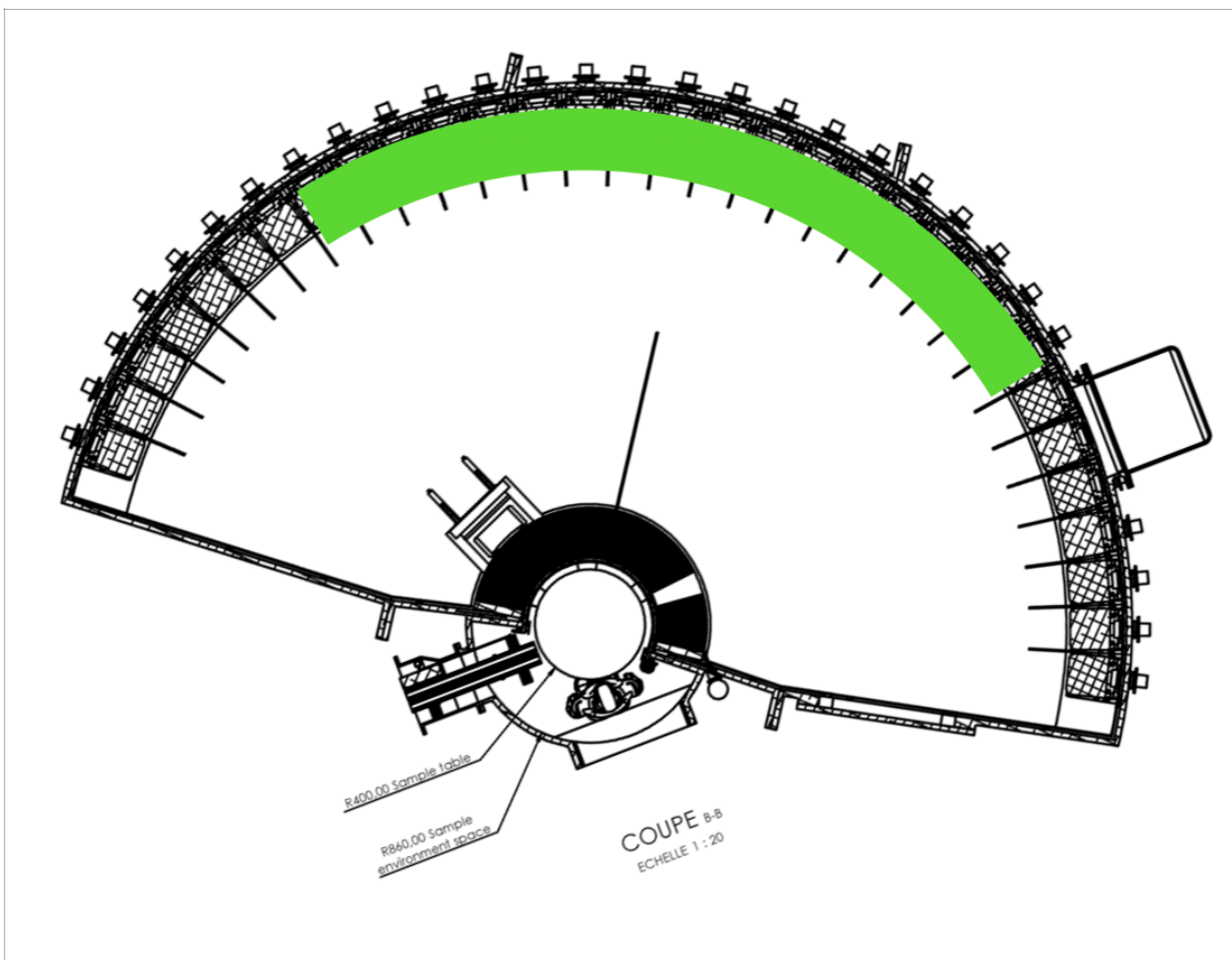
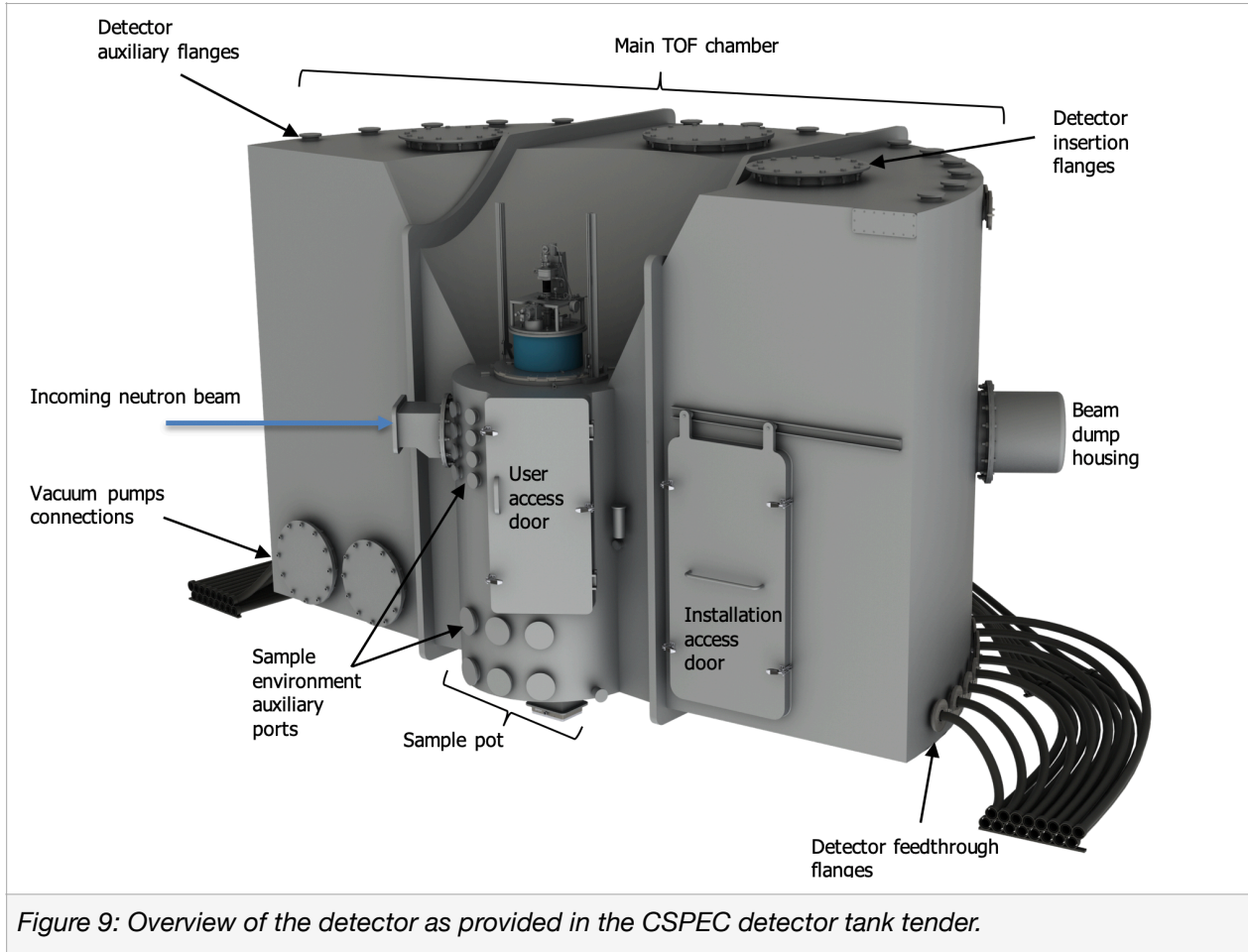

Figure 8: CSPEC Detector coverage. Full detector coverage = 2.65 Ster. Green: Day 1 detector coverage = 1.48 Ster.

Detector tank

The tender for the detector tank will be published in 1 - 2 weeks (design & manufacture) . We expect a formalised answer by December 2020.



The main requirements from a scientific perspective are :

1. Retain a vacuum level of at least 10^{-4} mbar, comply with the leak rates.
2. Within the sample pot and up to 1.45 m radius of the sample point, the base material, welding seems and all built in components such as prefabricated flanges shall have an 'as built' relative magnetic permeability $\mu_r < 1.01$.
3. Outside the 1.45 m radius from the sample position non-magnetic materials shall be used , a $\mu_r < 1.15$ is the requirement for the bulk material of the shells and the as-built condition, welded seems shall have a $\mu_r < 1.6$, non-compliances due to a design option have to be addressed during PDR and exemptions agreed at CDR
4. All inner surfaces of the chamber will be dressed with sheets of cadmium of 1 mm thickness. Due to the flexibility of Cd sheets, a sub frame of aluminium profiles will be installed in all surfaces but the floor. Cd sheets will be riveted to 2-3 mm aluminium sheets and then screwed on the sub frame profiles.
5. A gate valve (4 mm Al) will be placed in front of the radial collimator for experiments that require a non-evacuated environment or in the case of sample changes. A protective barrier will engage when entering the sample environment area, see Figure 10.
6. The tank design can accommodate both ^3He and MG detectors.

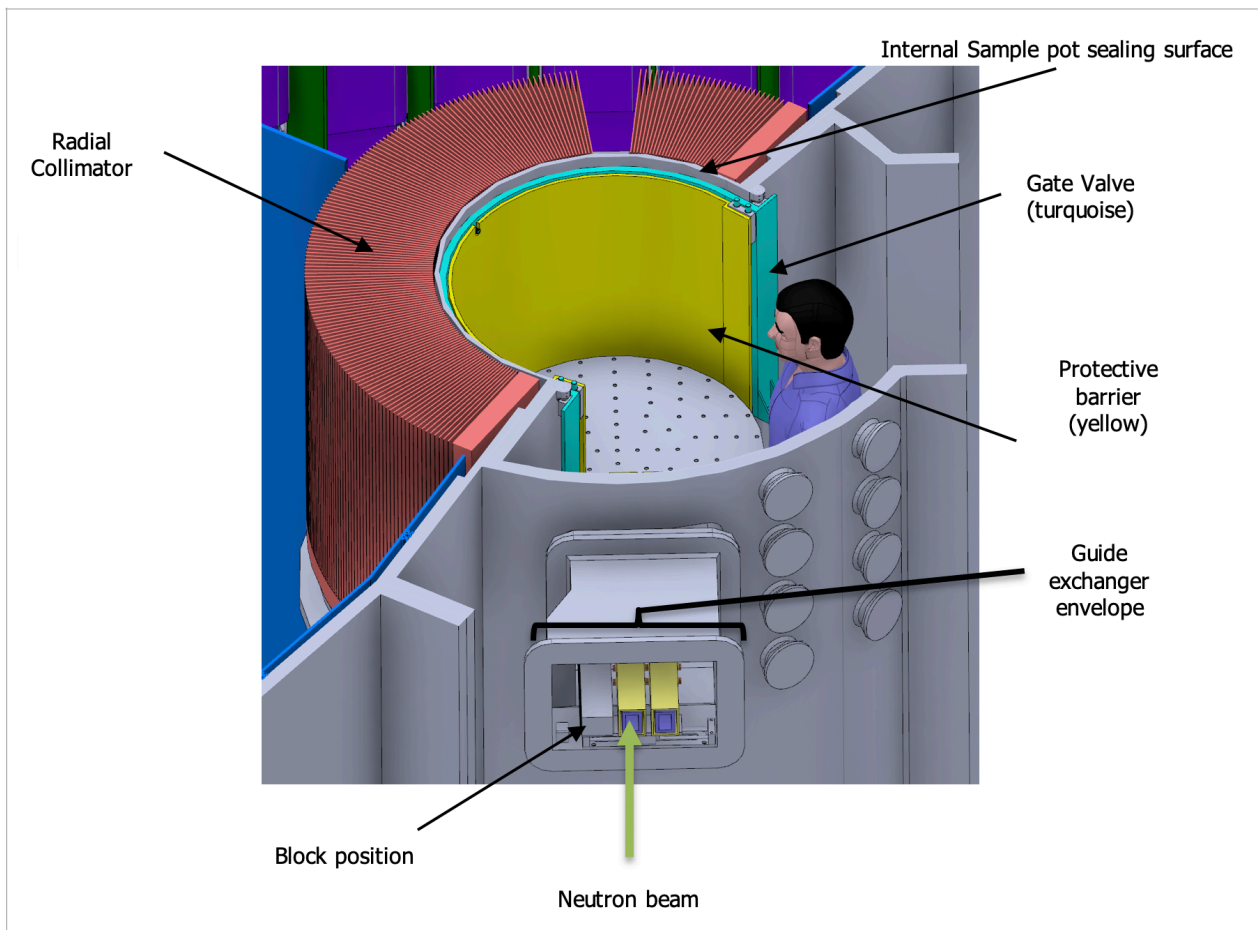

Figure 10: Overview of the sample environment pot within the detector tank as provided in the CSPEC detector tank tender.

Detector alignment and vanes.

Upon completion, there will be 32 detector vessels within the CSPEC detector tank, see Figure 8. Each detector set will be mounted in a vessel with individual alignment mechanism that can position the detector with a 50µm precision. The alignment mechanism consists of a top hook, with X and Y tilt and Z adjustment Figure 11(right, top) and a bottom mechanism that allows rotations (with a resolution of < 0.5 °) in all the planes including X and Y alignment and the final fixation of the system, Figure 11(right, bottom).

Secondary collimation vanes will be installed and fixed to the top of the detectors. Al sheets, 3 or 4 mm thick coated in Gd₂O₃, are mounted in a supporting frame that can be adjusted to position through a hinge mechanism. The concept is shown in Figure 12. This design aims to guarantee that the vanes are straight so that the detectors are not shadowed. The vanes can be removed separately or with the complete detector.

Prototypes of the mechanism and solutions are being manufactured at LLB and will be mounted in a mock-up of the detectors tank, simulating physical and spatial restrictions. The aim is to test and optimise the design and develop the alignment procedure for the detectors and vanes.

We aim to simplify the installation and as such a full-scale detector vessel and 2 wooden dummies have been built for this purpose. These will also be used to check the detector alignment and vanes.

A current unknown is whether Gd₂O₃ close to the detectors, for the absorbing vanes, will scatter too many gammas and thus elevate our shielding requirements. MCNPX calculations are ongoing.

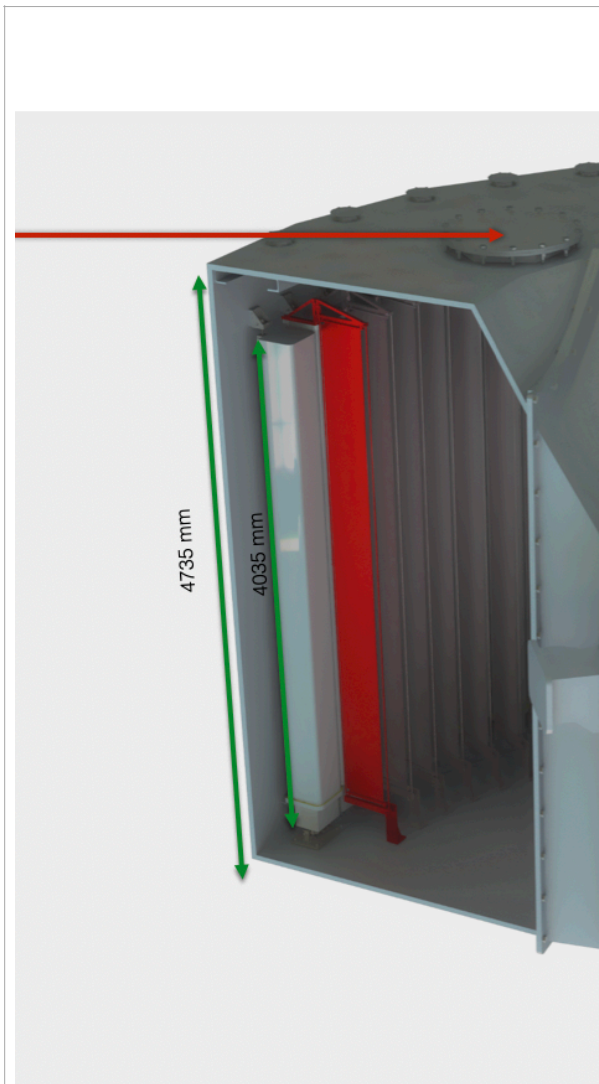

Figure 11(left). A detector vessel positioned in the detector tank. The arrow shows the extraction hole in the detector tank.

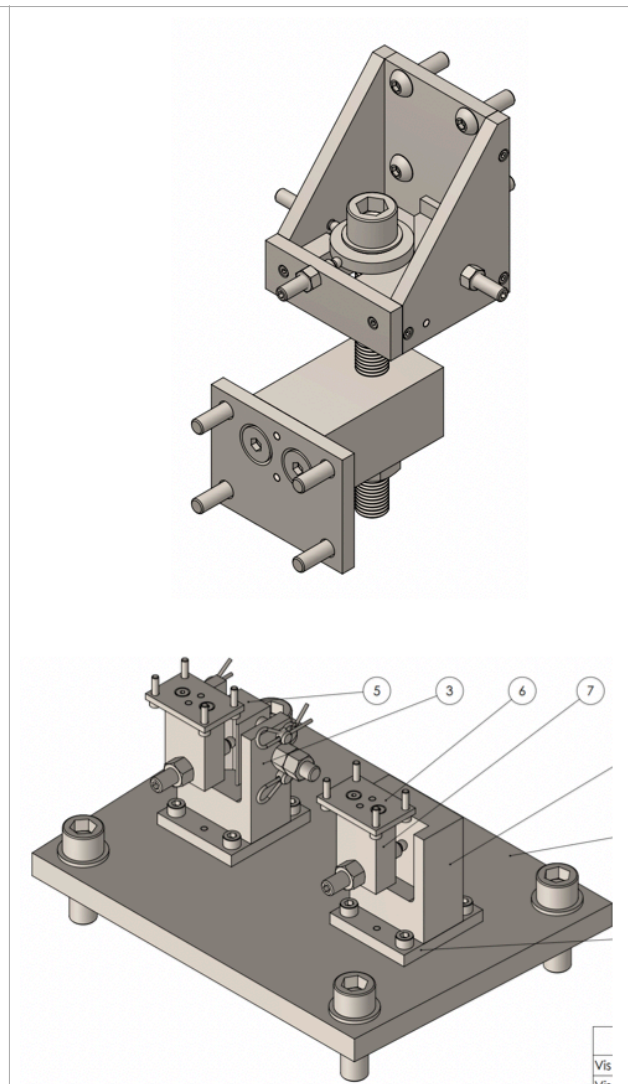
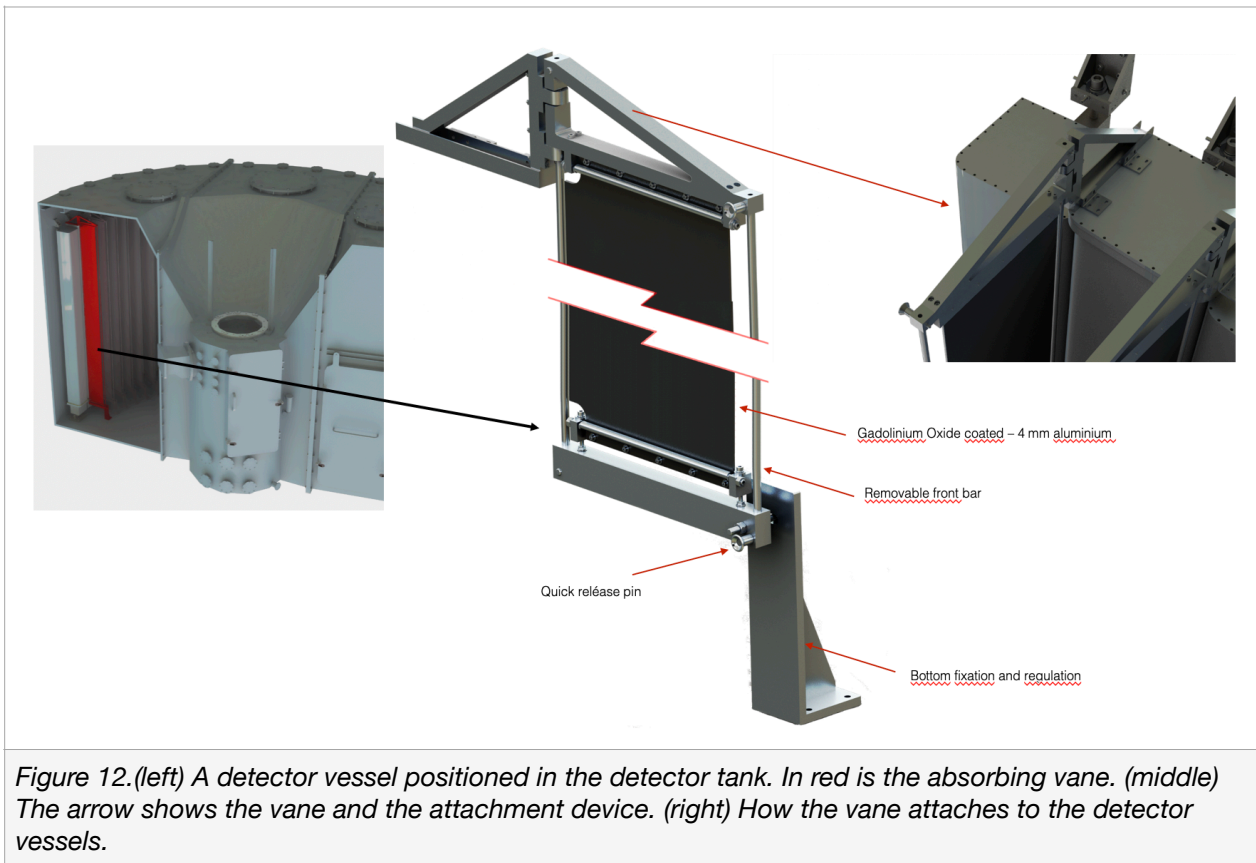

Figure 11(right). Alignment features for the detector vessels.



Radial oscillating collimator

The CSPEC radial collimator enhances the signal to noise of the CSPEC instrument via the use of strategically placed oscillating absorbing septa starting at a radial distance of 504 mm from the sample position and extending out to 700 mm with an angular spacing of 0.8° extending from the sample position. These parameters ensure that any scattering beyond a radial diameter, from the sample, of 48.87 mm and with a scattering angle greater than 2.4° will be suppressed. Spurious scattering from sample environment tails will be absorbed.

The radial collimator will be moved $\pm 1^\circ$ with a frequency of 0.1 Hz. The oscillating mechanism is under development at the LLB.

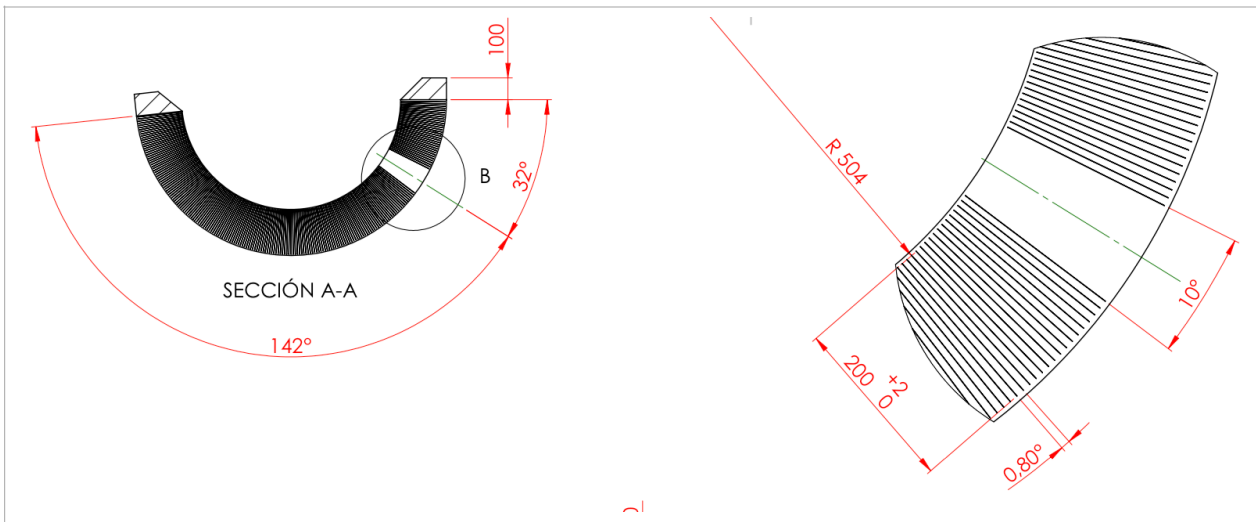

Figure 13 (left) CSPEC Radial collimator. (right) Dimensions around the incident neutron beam.

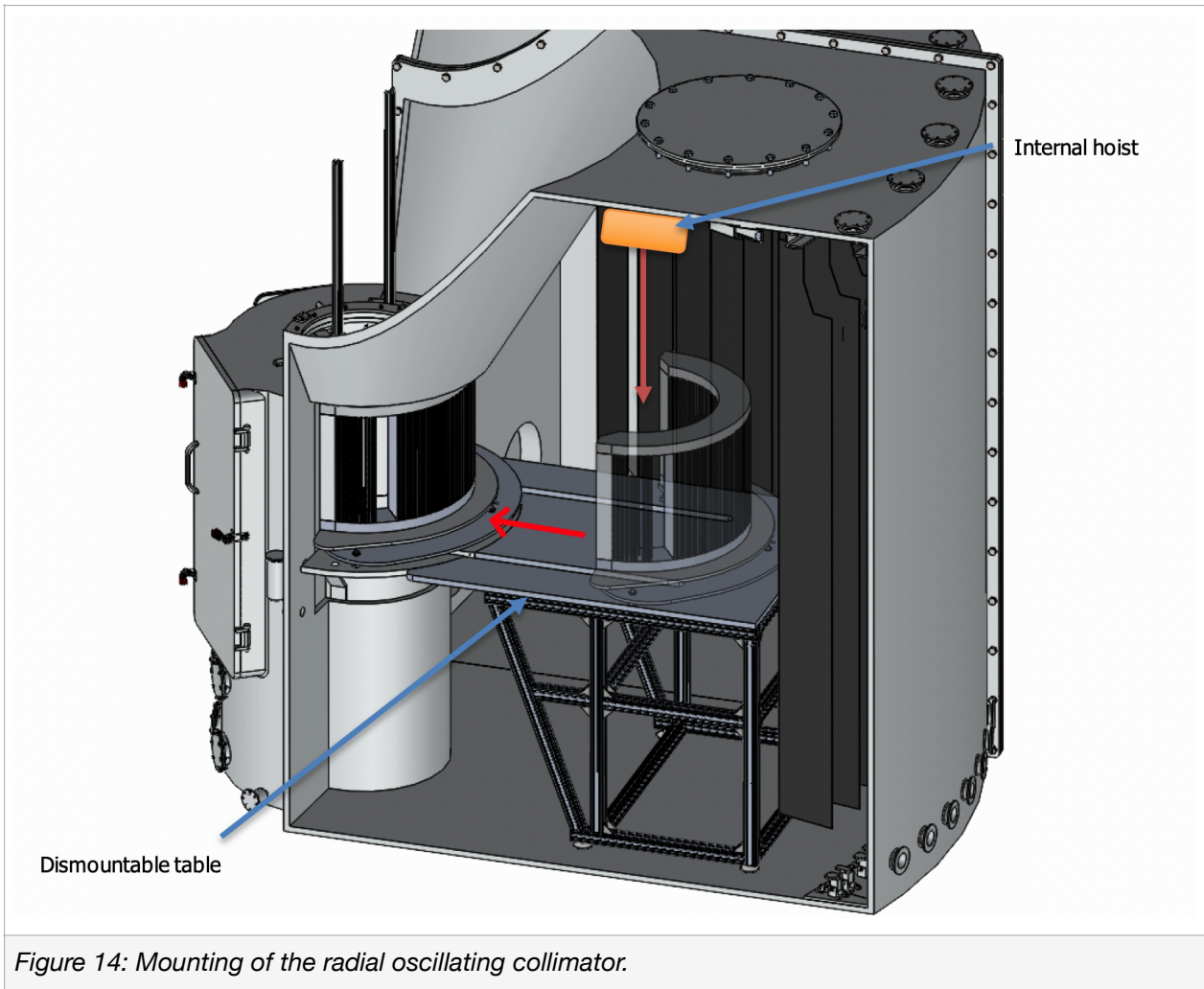

Figure 14: Mounting of the radial oscillating collimator.

The coating of the collimator blades will be Gd_2O_3 . All surfaces of the collimator shall be covered with a neutron absorbing material layer of at least 0.025 mm of Gd_2O_3 , Gadolinium of natural isotopic composition.

Choppers

Quotes have been received. Discussions will close on the 9th October.

Sample environment

Comment from previous STAP report:

Sample environment provisions – good to see collaborations set-up for soft matter, however it is unclear if the instrument is ready for the first set of experiments due to lack of information. We would like to stress to the ESS management that lack of provision of > 6T magnetic fields will seriously compromise attracting the best science. We recommend that a stronger magnet is sought (e.g. through 3rd party funding).

The SAD group has provided us with the following sample environment list for the CSPEC instrument. This list is consistent with our expectation as derived from the scope setting meeting.

This list is missing two items

1. Sample rotation stage (CSPEC will procure)
2. 12 - 14 T magnet.

System	Details	partners		status
6.5 T Magnet	Ex-HZB VM-2 +Dil. insert	ESS/HZB	2 nd hand; integration to start Q1/2021	
Cryofurnace	Inst. specific 6 pos. changer	LLB	requirements agreed; similarities w. BIFROST	
Wet cryostat	Standard Orange Cryostat	LLB	to be started based on 2 nd hand system	
DAC uniaxial	2 GPa + low T	LLB, KU	collaborative project completed	
hi-p: clamp, PE	2, 20, 50 Gpa + low T	LLB	TA ready to be activated; PE available	
Humidity cell	Wide angular access	ESS/EE	part of EE in-kind, based on existing design	
Pump-probe	In-situ laser trigger	EE	already used by partner; integration to be started	

We disagree on the level of the status afforded each component but we are collaborating with the sample environment team to ensure equipment will be available and commissioned before TG5.

On day 1 the CSPEC sample environment will consist of:

1. Cryofurnace ($1.7 < T < 650$ K)
2. Dilution insert (0.3 K)
3. Sample changer (6 positions)
4. 6.5 T magnet

in addition to sample environment from the pool. There has been, as yet, not solution to the lack of a high field magnet. We will apply for 3rd party funding.

In addition : The sample environment space has been defined in the detector tank CTV (approved in August 2020). The sample pot has been designed to allow the space and flexibility needed to accommodate several sample environment equipment (available at CSPEC, within the ESS pool or provided by users) to cover the broad scientific case for the instrument. The gate valve concept will allow to separate, when needed, the sample pot from the detector tank.

Regular meetings with the SAD group took place and are scheduled in the near future to ensure progress on the in-scope equipment and relevant equipment within the ESS pool. A first version of the CTV for the cryofurnace has been drafted and revised by the SAD group ($1.5 < T < 650$ K). Once the CTV is accepted by the ESS, the cryofurnace can be purchased. The definition of the requirements for the other pieces of equipment is ongoing.

Further extensions of the sample environment equipment (e.g. additional in situ capabilities, optimized high-temperature/high-pressure cells, combined high-field/ultra-low temperature/high-pressure system) are still being explored via external funding opportunities and collaborations.

DMSC – ECDC (detector data acquisition)

Regular (biweekly) meetings with DMSC scientist Morten Jagd Christensen have started and are foreseen in the next months to define the data acquisition and transformation processes. Sketches of the detector spatial distribution have been provided by the CSPEC team as requested by DMSC. The exact wiring of the detector will be provided by the detector group, once defined.

We are in the process of recruiting a data scientist who will work at the DMSC but closely with Bifrost and CSPEC to develop our software requirements from data acquisition to data analysis.

From previous STAP report:

We ask for (1) a clear commissioning plan that shows the path for early experiments and (2) a set of first day bench-mark experiments including necessary provisions such as sample environment and software for reduction and analysis, with urgency for CSPEC and BIFROST.

We are currently working on a detailed commissioning plan with a plan for early experiments but this is not yet complete. We will present this at the next STAP meeting.

Electrical installation

We will join the ESS common electrical project led by S. Birch.

Polarisation analysis

We have ensured that polarisation analysis will be possible on CSPEC once the budget and technical facilities are made available by making careful decisions of a number of components. The components that we have paid particular attention to are (see Figure 15 for relevant numbers)

- Exchangeable guide prior to M chopper (1)
- Non magnetic Mo/Ti guides between M chopper and up to sample (2)
- Space for guide fields (3)
- Enough space in sample environment to facilitate He3 cells. (4)
- Materials up to 1.45 m from sample area will have a magnetic permeability up to $1.01 \mu_r$. (5)

The expectation is that CSPEC will use a supermirror to polarise the incident beam ($P \approx 95\%$) followed by a Mezei Flipper. The science case for uniaxial or xyz polarisation analysis has not yet been considered but we are closely following developments on LET which has recently shown impressive scientific results with uniaxial polarisation analysis. The sample area is nevertheless large enough to accommodate Helmholtz coils. The scattered neutrons will be analysed using a ^3He Analyser (SEOP). W. Lee has recently performed some preliminary FEMM calculations to determine the magnetic profile prior to the monochromatic chopper, for the polariser and flipper, and at the sample position with a Tetracoil. The FEMM calculations were performed using the CSPEC instrument parameters as defined in the detector tank CTV. The FEMM calculations show that polarisation analysis is consistent with current design features.

Figure 15: CSPEC Secondary spectrometer showing the particular components that can be changed or have been optimised for polarisation analysis.

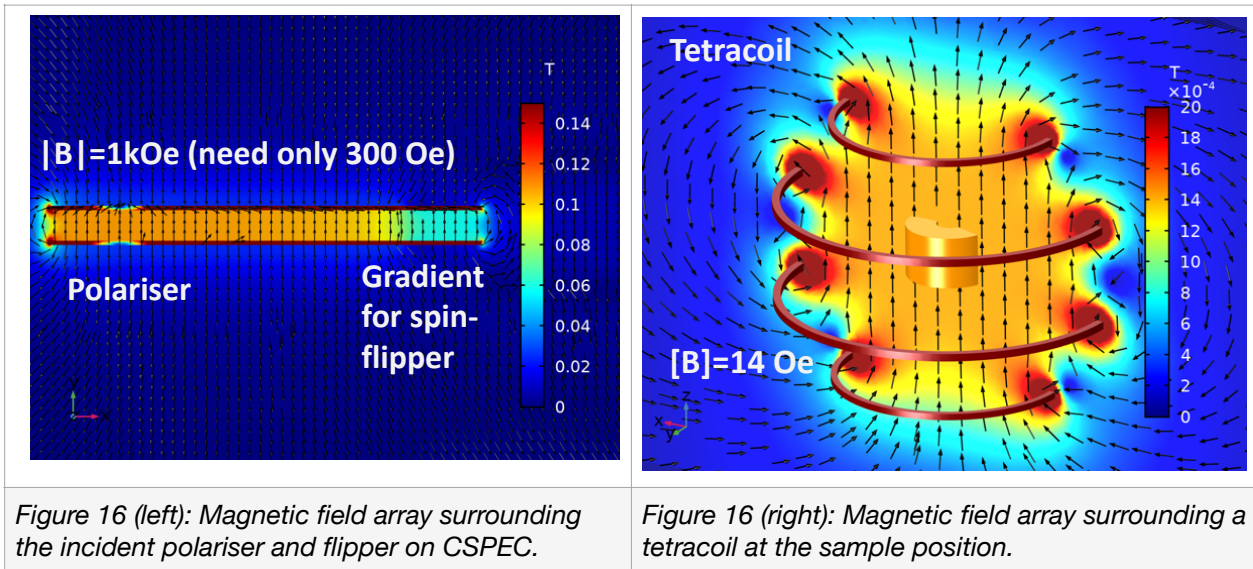

Figure 16 (left): Magnetic field array surrounding the incident polariser and flipper on CSPEC.

Figure 16 (right): Magnetic field array surrounding a tetracoil at the sample position.

Consistent with current design features

Control cabin

CSPEC control cabin will have space for 6 people to sit and work at a desk comfortably. It will be divided into two separate compartments. The bigger space, 35m², will host the control cabin. A smaller room, 17.5 m², will be used as a separate room for discussion with the previous experimental team at the change of experiment or will be transformed into a small technical space (to be decided).

A first draft of the CTV document has been started. Several details are still under definition.

Timelines

From previous STAP report

Project progress – in order to provide a more accurate assessment, we ask to see a spend profile and a task schedule (% completion).

We cannot provide a spend profile nor a % completion but we attach an overview of the LLB and TUM milestones as provided to the ESS project group for September for milestones up to August 21.

As stated in the introduction, the CSPEC TG5 (hot commissioning date) is December 2022. Green is completed, while orange is currently delayed (EV is earned value).

Milestones TUM		Dates		
Description	Agreed Baseline	Expected	Complete	EV %
1: Tollgate 2 meeting	Feb-17	Feb 17	Feb-17	0
2: TG2 Review completed, Phase 2 starts	Aug-17	Aug 17	Aug-17	1
3: Start of Guide production: TUM	Aug-18	Aug 18	Aug-18	2.25
4: NBOA CTV	Jan-19	Jan 19	Jan-19	0
5: NBOA contract signed	Jun-19	Jun 19	Jun-19	0.5
6: BBG CTV	Jul-19	Jul 19	Jul-19	0
7: Bunker feed through CTV	Jul-19	Jul 19	Jul-19	0
8: NBOA TG3.2.2.1	Sep-19	Sep 19	On-going	0.25
9: Detector design document ready	Oct-19	Dec 19	On-going	1
10: BBG contract signed	Oct-19	Oct 19	Nov-19	0
11: Bunker feed through contract signed	Oct-19	Oct 19	Nov-19	0.5
12: Guide production TUM - Batch E01 / E02(1), FAT	Nov-19	Nov 19	On-going	6
13: Shielding calculations completed	Nov-19	Nov 19	Nov-20	1
14: Detector manufacturing contract signed	Dec-19	Dec 19	June 20	1
15: Monitors TG3.2.4	Jan-20	March 20	On-going	1
17: Vacuum housing TG3.2.3	Jan-20	June 20	October-20	1
18: Focussing nose contract signed	Feb-20	Not valid, manufactured by TUM		0.5
19: NBOA FAT	Feb-20	Nov 20		0.5
20: Detector TG3.5, Detector group	Mar-20			10
21: BBG TG3.2.2.2	Mar-20	Dec 20		0

21: BBG TG3.2.2.2	Mar-20	Dec 20		0
22: TG3.2.1 Guide system - outside bunker	Mar-20	June 20	October 20	1
23: Detector: TG3.5, Documents	Apr-20			1
24: Guide system start of installation - outside bunker: TG4.2.1	May-20	August 21		0.5
25: Guide production TUM - Batch E01 / E02(1), arrival on site, SAT	May-20	June 21		4
26: Guide E01/E02(1) start of installation	May-20	August 21		0
27: Bunker feed through TG3.2.2.3	Jun-20	Dec 20		0.25
28: Shutter CTV	Jul-20	Dec 20		0.25
29: Slit CTV	Jul-20	November 21		0.25
30: TG3.2.2 Guide system - inside bunker	Aug-20	March 21		0.5
31: Focussing nose (Guide exchanger) TG3.3.2.1.1	Sep-20	March 21		0.5
32: NBOA arrival on site, SAT	Sep-20	December 20 Hans Dieter		0.5
33: NBOA TG4.2.2.1	Nov-20			0.5
34: NBOA start of installation	Nov-20	Depends on Target		0
35: Shutter TG3.6.1	Dec-20	May 20		0
36: BBG FAT	Dec-20	June 21		0.25
37: PSS: TG3.6	Jan-21	Jan 22 Depends on detector tank/ cave		0
38: Tollgate 3 (EOR/CDR)	Jan-21	Jan 22		1.5
39: BBG arrival on site, SAT	Jan-21	August 21		0
40: Bunker feed through FAT	Jan-21	August 21		0.5

Milestones LLB	Dates			
Description	Agreed Baseline	Expected	Complete	Ev %
1: Tollgate 2 meeting	Feb 17	Feb 17	Feb 17	0
2: TG2 Review completed, Phase 2 starts	Aug 17	Aug 17	Aug 17	1
3: Primary spectrometer shielding: TG3.7 We are part of the ESS primary spectrometer shielding project.	T0+10 months (Estimated : May-2020)	May-20	May-20	2
4: Choppers: TG3.1	T0+14 months (Estimated : Sep 2020)	Sep 2020	Dec 20	3
5: Cave: TG3.4 Extensive shielding calculations are on-going.	T0+15 months (Estimated : Oct-2020)	Oct 2020	April 2021	2
6: Vacuum Tank including detector vessels: TG3.3, TG3.5 Vacuum tank CTV	T0+16 months (Estimated : Nov-2020)	Nov 2020	March 21	3