

Sample Environment Q1 / 2021 report for STAP

Top achievements

Importance	Team	Achievement	Enables
	Science SAD/SE	Implementation of project planning tool (Big picture)	The implementation of an adequate project management tool will enable an overview and a better follow up of all the projects, and will highlight bottlenecks in the delivery of Sample Environment Ssystems (SES)
	Science SAD/SE	Creation of common project (working groups) between ESS Teams	These synergies will enable us to overcome the lack of human resources, to avoid duplication of solutions within the organization and to share competencies and knowledge
	Science SAD/SE	B02 : Installation of the SE-ECDC test platform (YMIR) and robotic platform in the SE area	Create and improve synergies and communication between Motion Control, ECDC and SE groups
	Science SAD/SE	High Pressure TA signed	Procurement of High Pressure SES
	Science SAD/SE	Contract with HZB to procure 2 nd hand equipment (2 magnets and a dilution fridge) signed	Increase the number of SES for the pool
	Science SAD/SE	Orange Cryostat cooled down at 77 K	Starting the process of commissioning and integrating a complete cryostat system – Creation of a “pumping cart” common project with the ESS vacuum group and ISIS (needle valve)
	Science SAD/SE	8T magnet tender published	Procurement of 8T magnet for MAGIC

Importance	Team	Challenge	Mitigation
		Construction of SES from EE delayed due to COVID	Machining done at ESS
		Delays in receiving SES from EE	Keeping an eye on them
		Delays in moving to E03: late arrival of the UK installer, impossibilities to visit machine manufacturers, long delay of response for quotation requests	Keeping requirements to minimum and start moving in when allowed

		Added friction in interactions within the group and with partners due to lack of communication (informal and formal) caused by COVID situation	Creation of new common projects and presence on site of the group leader more frequent
		Delays in InKind procurements	Keep in contact with partners

Organization, time planning and documentations:

Given the number of Sample Environment systems which have to be delivered in a short period of time, the approaching time of the Beam on Target and the lack of resources, a project planning tool has to be implemented. We chose Big Picture. In order to work together in a coherent manner, a training session will be organized in April 21. Once all systems' timelines have been implemented, a better overview of the work will be available and priorities will be set more wisely. Mechanical and control integration will be done as soon as possible to avoid delays: the control integration will be started as soon as the electronic part has arrived and the mechanical integration as soon as drawings are available.

In addition, to overcome the lack of resources within the ESS and knowledges within the SE group, a few actions have been taken:

- The creation of new ESS common projects (or working groups): members of the SE team will work with members of other ESS groups on specific projects which are beneficial for all the groups involved: for example, the Motion Control group will help members (MESI team) of the SE team to choose and integration of motors; The vacuum group is helping the SE group to build a "pumping cart" for the cryostats.
- The instrument scientists can lead the delivery of some of the SES, when the budget is held by the instrument and the SES is specific to it. The instrument scientists will be included in the SE team and therefore will follow the Way of Working of the SE group which include to setup Milestones, to provide documentations (Safety and reviews), to report on progress (weekly meetings), to follow the rules to access SE resources.

The SE team will continue to work on actions beneficial for the whole ESS and which go toward standardisation, such a as the standardised mechanical mount and sample holders.

In order to cope better with the lack of resources within the group, the platforms will slowly disappear. This will enable the technicians to move more freely from one project to another and to increase their competencies while approaching operation mode. The areas of expertise for the engineers will remain as they are currently: A. Holmes for High Field and Temperature; H. Schneider for Fluids, liquids and complex fluids; M. Guthrie for Pressure and Mechanical Processing; N. Ekström and A. Hagelberg for Software integration and Octopy development (NB A. Pettersson has moved to ECDC).

The documentations are being constantly updated in EAM (Asset management), CHESS (Safety documentations) and in confluence. But clarification on the necessary documents, their format and their content for each project is needed, the aim being to comply with the ESS

engineering handbook. These milestones will be implemented into Big Picture with a direct link to the documents.

Labs and Workshops:

- **E04:**
 - **Temporary labs space** for Fluids testing and Electrochemistry installed and operational.
 - **Small workshop** for smart mechanical work with little lathe, milling and drilling machines operational
- **E03:**
 - **Top-loading Sample Environment Interface:** A test frame for verifying the standard top-loading interface for ESS, fabricated at the end of 2020, has been installed in the E03.100 laboratory. In addition, a metrology network has been established in the E03.100 lab to allow measurement of the frame during testing.



- **B02:** For the time being, the SE area will be used by ECDC to host the YMIR mock up cave/instrument. When the SE group will need a space outside the restricted zone to test arriving pieces of equipment, the area will be returned to the SE group.

High Pressure:

- The **Technical Agreement with CEA** to provide High Pressure SE (including gas cells, clamp cells, 10 kbar He compressor, PE cells, gas loading device and dedicated CCR for PE cells, value €690k) has been signed in January 21 and the kick-off meeting was held in February.

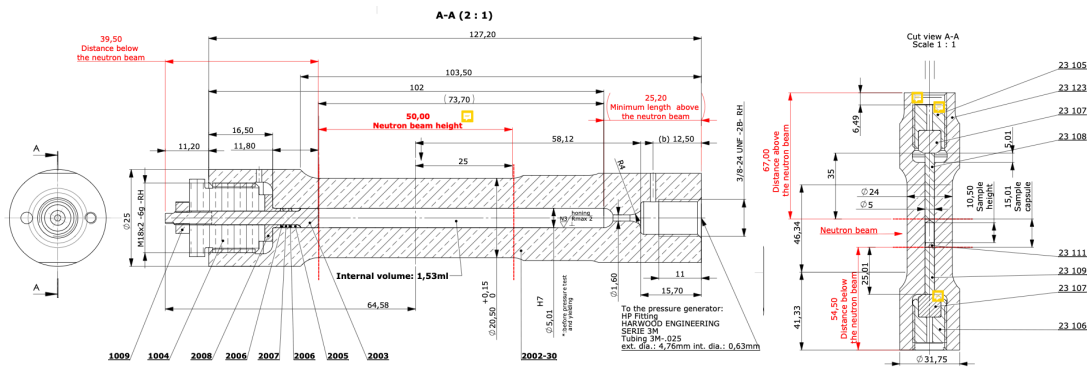

- Pressure testing facility.** A tender for the physical manufacture of a pressure testing facility has been published on the 09/03/2021 and will be open until 22/04/2021. In parallel, an agreement has been signed with the Swedish Military Research arm ("FOI") to conduct an independent review of ESS safety procedures and documentation in relation to high-pressure activities (To kick off 30/03/2021).

Mechanical processing: A draft specification for a 50kN rig, optimized for imaging, has been prepared and reviewed by instrument stakeholders (ODIN & BEER) during IKON in Feb 2021. The process of safety and quality review of rigs has been initiated using a small portable rig that we have access to. Some clear requirements have been established that will apply to all rigs at the ESS.

Temperature

- The Orange cryostat was successfully cooled with liquid nitrogen to 77K using the warm valve control method.

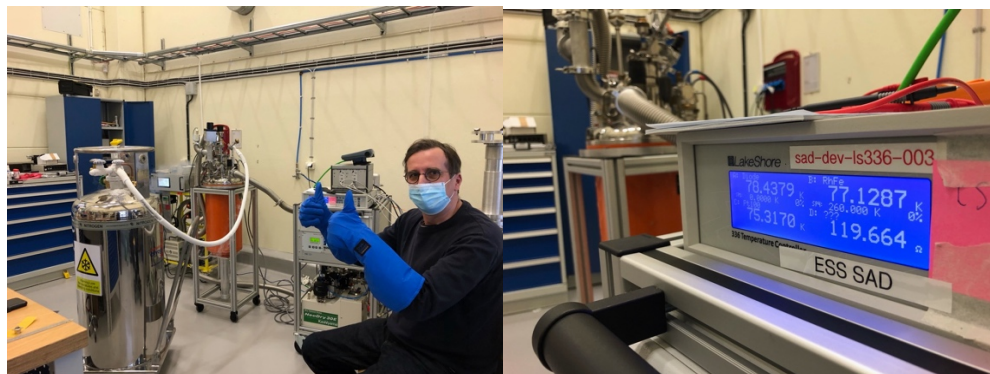

- Two each of Lakeshore 350/372 units + a number of calibrated & uncalibrated cernox thermometers have been purchased. An Oxford Mercury iTC and IPS are also available for integration and testing.
- Two 250l Helium & four nitrogen mobile dewars have been purchased. The filling connections on the nitrogen dewars have been chosen to be compatible with existing MAX IV and newly commissioned ESS automatic filling stations.
- A liquid nitrogen filling station is now available on site.
- A Nordforsk project to design a cryostream/hot air blower system and an induction furnace has started in January 2021. The postdoc, Jakob Voldum Ahlburg from Aarhus University is leading the project for DREAM and HEIMDAL.

Magnetic fields:

- The call for tender review (CTV) for the Warm Bore magnet has been carried out with input from ESTIA and LOKI. The system planned is one similar to the FRM2/TOFTOF HTS110 2.2T magnet. As this is a symmetric magnet, calculations are needed to ensure compatibility with guide field and polarized neutrons, before the tender publication.
- The design of a measurement device for testing magnetic forces on bottom loading instruments has started.
- The purchase order for the transport box for the 15T magnet from HZB has been sent. The manufacturing will take around 6 weeks. At the same time a contract with HZB to purchase 2 additional magnets (2nd hand equipment) and a dilution fridge has been signed
- The tender for the 8T magnet has been signed and the call has been published.

Fluids and Gases:

- **Humidity chamber:** a design has been proposed by the University of Tartu. However, due to a closure of their workshop, the manufacturing of the cell could be delayed for an uncertain time. Therefore, it has been decided that ESS will manufacture the parts. Our design engineer is actually verifying the compatibility of the available drawings with the requirements of the ESS mechanical workshop. The machining will start as soon as the mechanical workshop is up and running.

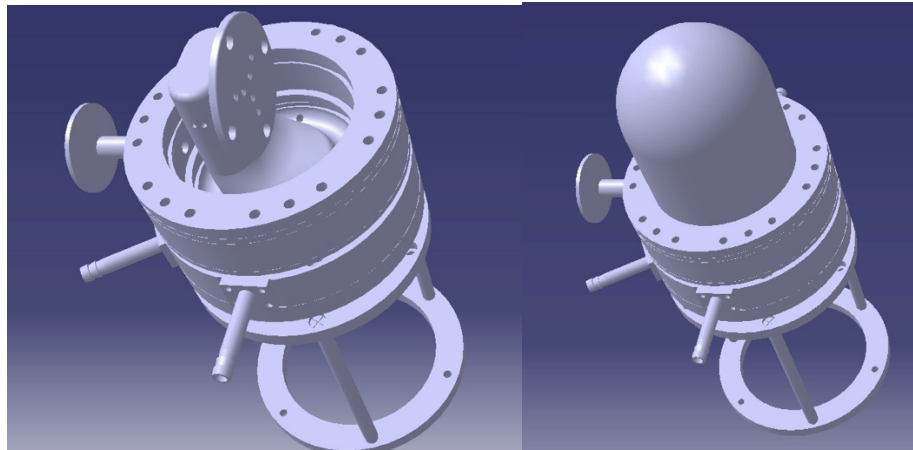

- Tests on a **manual gas handling system** have been successfully performed. The **automatic** one, provided by the IK partner, should arrive in the following weeks with the **Stopped-flow cell**.

Soft matter:

- A **rheometer** has been purchased from Anton Paar and we are waiting for the delivery. In the meantime, an old rheometer is actually available in E04 and is being tested and used for training.
- A detailed quotation for the **SANS sample changer**, designed and manufactured by the SE Team, has been prepared and proposed to the instrument team of LOKI. Given the knowledge of the LOKI team and their partner ISIS on this type of SE system, it has been decided that J. Houston will take over the lead for this project. She will nevertheless follow the WoW of the SE team regarding the documentations, reporting and access to resources (design, manufacturing and integration).
- For the **solid-liquid cell** for ESTIA, a SRESS project has been granted and this project will be led by Adrian Rennie at Uppsala University and T. Arnold.

Electrochemistry: Some delays have occurred due to COVID but also some health issues of the IK partner. Nevertheless. The project is continuing with the Preliminary Design review of the outer part of the cell with the definition of the dimensions and the number and types of connectors needed. The constraints of a dry cryostat, which would be able to host an EC cell, are currently being defined.

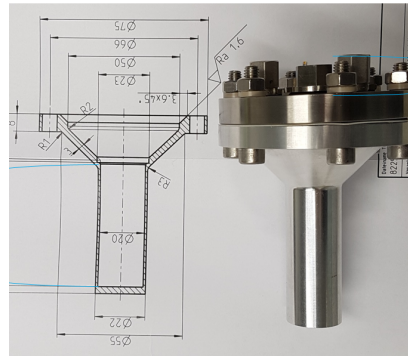

Integration:

The applied integration workflow between SE<->ECDC<->ICS works well and provides a good structure for providing information. This workflow is now being extended to include the integration step from EPICS<->NICOS. The aim is to have one continuous integration project from SE to NICOS. Devices currently in the integration process:

- Vinci pump (High Pressure)

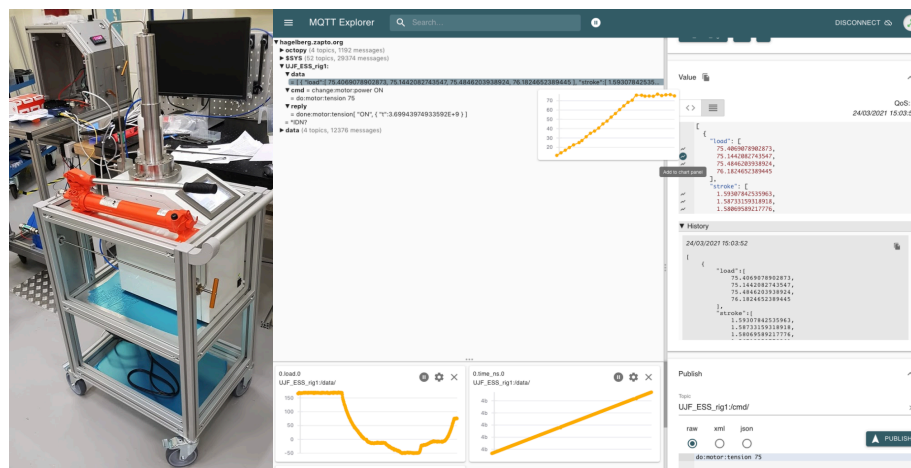

- N2/He Levelmeter (American Magnetics)
- Huginn Sub-cryostat
- Deformation rig, “Rig1” remote integration
- HPLC pump (Fluids): ready to start

A number of devices (syringe pumps, Julabo, Lakeshore LS224) are already integrated to EPICS and are now queued up for integration into NICOS. Access to NICOS interface is now available.

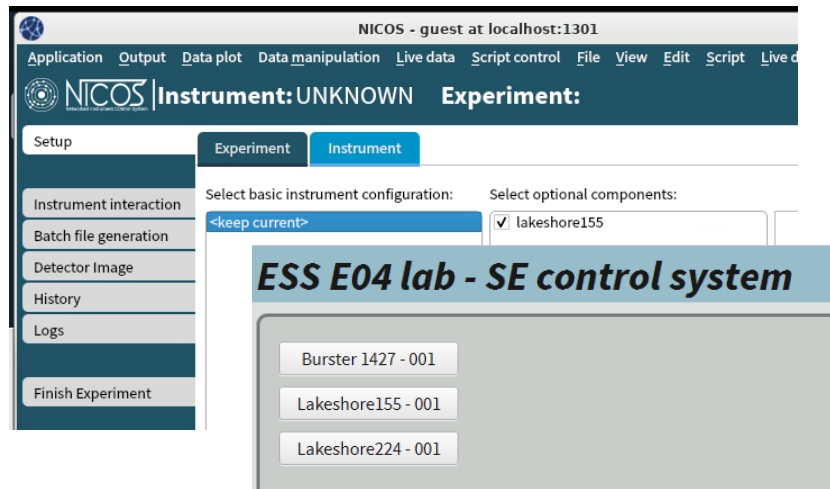

Octopy - a SECoP based local SE controls system

The main APIs and architecture have been refined and documented which has further helped remote and de-centralized development in the team (necessary due to COVID). Essential redesigns and alignments prompted a larger restructuring of repositories. The test system is now operational and consists of a Beckhoff PLC, a LakeShore336 and a Kepco power supply. These devices are communicating to Octopy via MQTT, TCP/IP and EPICS respectively. ECDC have provided support enabling planned tests for pushing SE data from Octopy to the ESS ECS filewriter. Discussions with ECDC are ongoing to find a way forward and define the support required (mainly EPICS) for Octopy at ESS. An Orange cryostat (TEFI) integration project is planned as the next step in demonstrating the capabilities of Octopy. A first operational version of Octopy is planned to be available at end of 21Q2.

Common projects:

- **He management:** The Helium recovery system main header pipework is ready for critical design review.
- **Standardized mechanical mount:** The first 3 non-magnetic KIPP components (prototypes) have arrived and have been tested. Unfortunately, even if the requirements are met in terms of resolution of positioning, some damage were observed. Discussions are ongoing with the manufacturer to find a solution (change of design or material)



- **Pumping Cart for cryostat:** This is joint project between The SE group, ECDC and the vacuum group. We are cooperating with ISIS who are upgrading their cryostat control systems also based on Beckhoff systems.