

# SKADI

## Current Status

SANS STAP October 2021

October 2021 | Sebastian Jaksch, Romuald Hanslik, Tadeusz Kozielowski, Henrich Frielinghaus, Alexis Chennevière, Sylvain Désert et al.

# SKADI layout

13.6.7.1.1 Beam extraction System-  
NBOA, BBG, Reflector  
FZJ

13.6.7.1.4 Beam geometry conditioning-  
Collimation and apertures +shielding  
LLB

13.6.7.1.7 Flight tube  
Feed Through bunker wall  
FZJ

13.6.7.1.8.2 Heavy shutter  
FZJ

13.6.7.1.5 Beam filtering system-  
Polarizer, Spin Flipper  
FZJ

13.6.7.1.3  
Chopper System  
FZJ

13.6.7.2 Sample Exposure System-  
Sample area, shielding  
FZJ

13.6.7.3.2 Neutron detector system  
Detectortube, detector vessel, shielding  
LLB

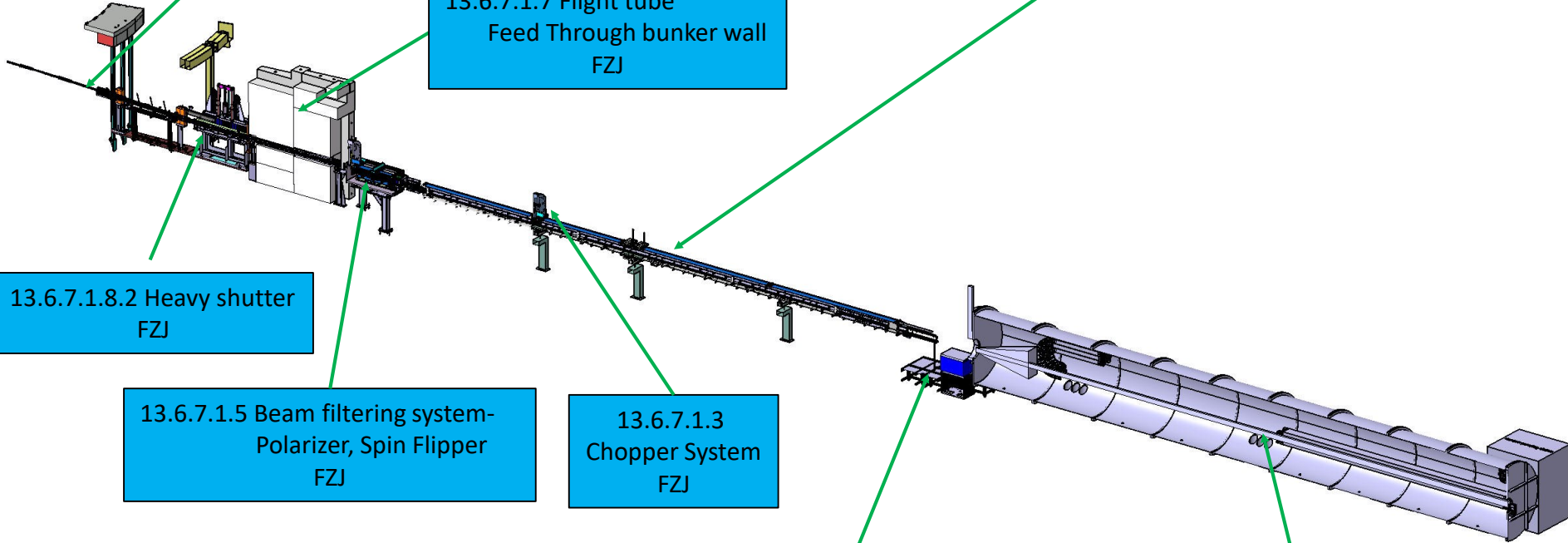

# Major Steps since last STAP

- NBOA delivered on site
- In-bunker components went through IDR, TG3 well under way
- Chopper components achieved TG3
- Collimation call for tender is through, signature imminent
- Sample cave went through IDR
- Common load spreading for SKADI and ESTIA at sample cave location: Agreed upon, included in design and schedule
- Detector tube call for tender is through, signature imminent
- Shielding for detector tube and collimation is in tendering process, data not yet published for bidders
- H1/H2 safety documentation submitted, very few comments, seems to be usable soon
- Continued work on DAQ chain for detector
- Sylvain now located at ESS, so we have on-site support

# NBOA delivery

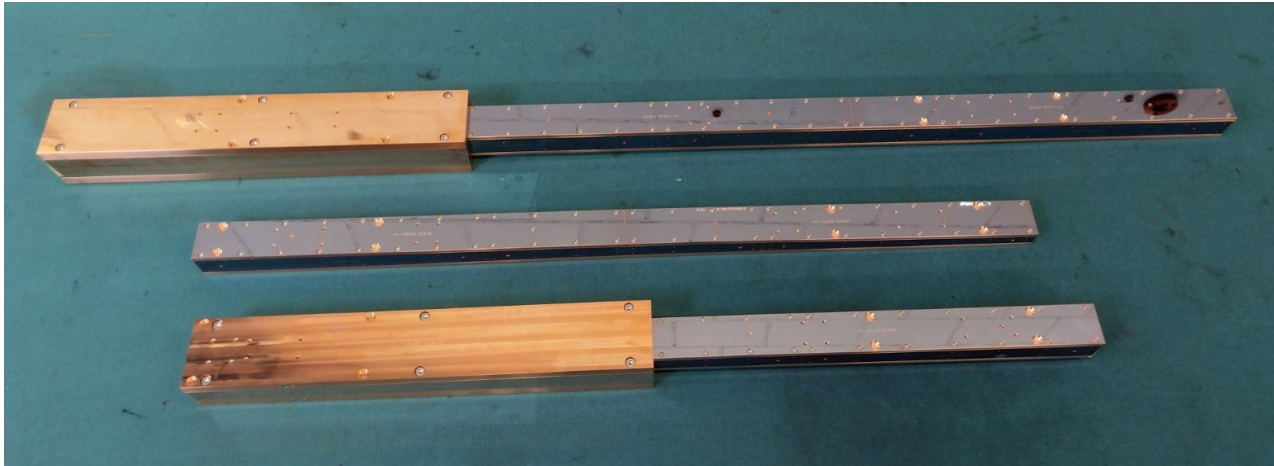

The NBOA has been delivered and is in storage at ESS, awaiting installation. NBEX monolith insert has to be manufactured first, CDR for that will take place October 5th 2021.

This is in line with the overall installation scheme (end 2022) and no drawbacks are expected for this component. There has been an unforeseen change in window thickness at the NBEX (1.5 mm instead of 1.0 mm) which will decrease neutron flux. The technical necessity for that will be assessed during the CDR.

# In-Bunker Beam Extraction

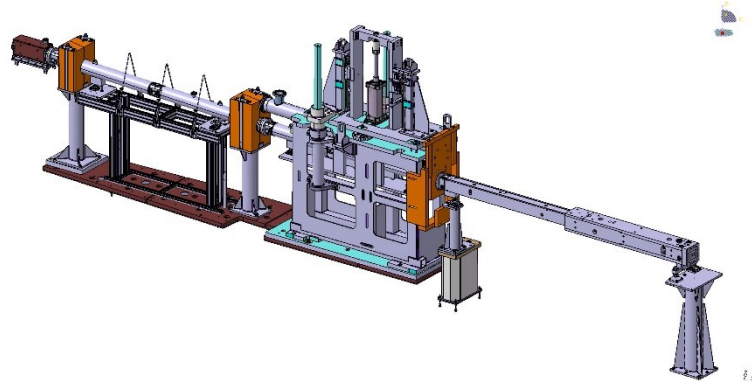

- Delivery and installation contracted for mid 2022
- IDR went well
- TG3 towards the end of the year

The in-bunker installation comprises the guide segment in the light shutter, the reflector setup to offset the beam out of line of sight, the heavy shutter as well as the bunker wall feed through. All components except for the heavy shutter will be supplied by Swiss Neutronics.

There were no major concerns raised during the IDR, the absorbing capabilities of the heavy shutter were assessed as being sufficient. However, the question of cross-talk between the instruments was raised. This seems to be outside the scope of the individual instruments since this crosstalk is mainly due to the general bunker background.

# Chopper

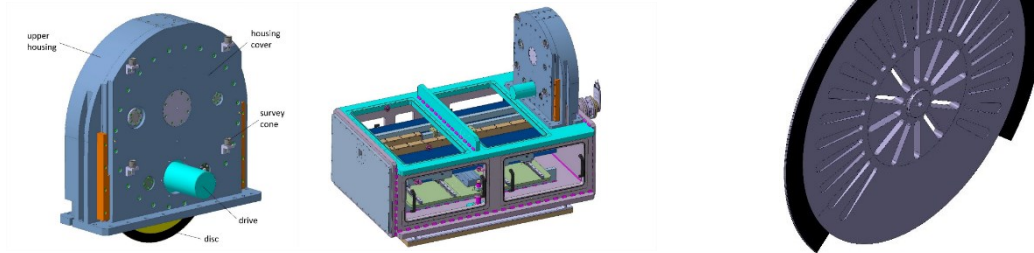

- TG3 meeting happened
- Can start manufacturing
- No concerns, simple chopper setup (two 14 Hz Choppers outside bunker)

TG3 was accepted without comments. Therefore, production can start as soon as the workshop is ready to take up production, after the DREAM choppers are ready. This is well in line with a installation Q3 2023. Since those are probably among the last components to be installed they are a component of low concern.

# Shielding

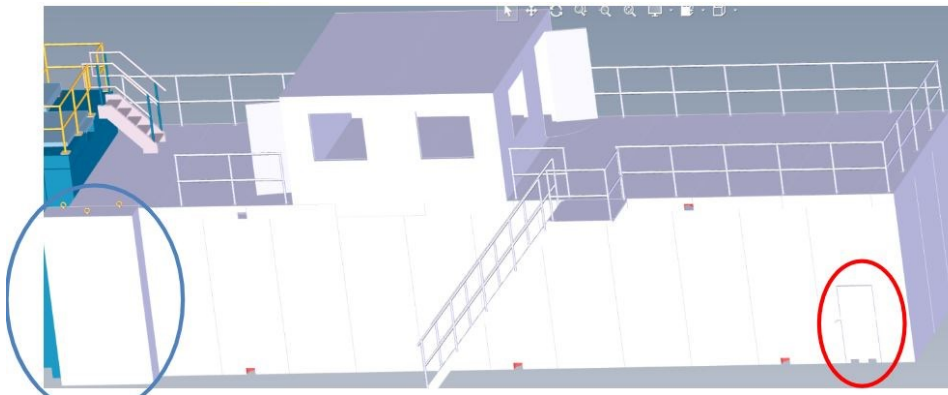
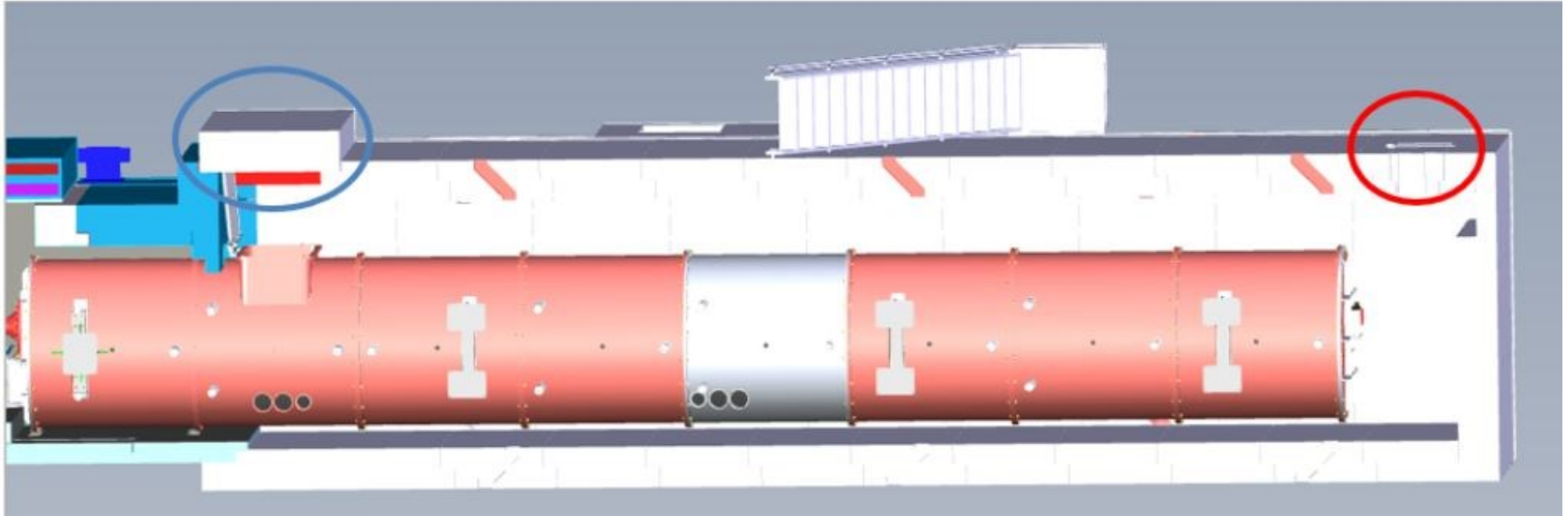

- Procurement is with administration (may take some time)
- However, very last component to be installed
- Foreseen to have contract ready middle 2022

# Collimator

- Signature for contract expected in October
- TG3 in mid-2022
- Expected delivery time 10 month after contract

Due to the call for tender scheme at CEA/CNRS the call for tender was somewhat delayed. However, this does not impact the overall schedule, since with a delivery time of approximately 10 month after TG3 and a TG3 in mid 2022 this allows an installation in 2023. We will stage the installation with the installation of the sample cave, which will take place around the same time.

Since the neutron guides as limiting components are all  $m=1$  with 3 cm x 3 cm cross section there is little risk in production of those.

For this section we therefore do not foresee any problems with schedule or production.

As a side note, the VSANS collimator sections are currently produced and being tested, piece by piece. However, due to the lack of neutrons throughout Europe we need to work on an optical alignment check for that component.

# Sample Cave

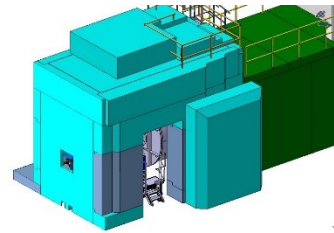
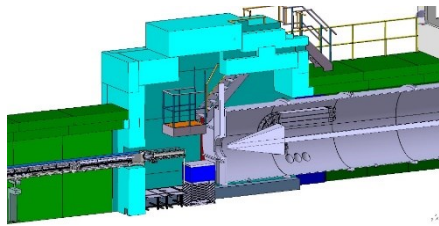

- Full installation contracted in 2023
- Load spreading slab to be installed in 2022 (shared with ESTIA)
- IDR with no immediate showstoppers

After the IDR the SKADI team is preparing for TG3 by the end of the year. The MCNP shielding simulations show that full instrument safety can be achieved at the full scope of functionality. The issue with the polarization has been solved by a 2 m exclusion zone of magnetic materials in the cave construction.

The cave segments will be pre-cast at the manufacturer's site and then be shipped to the ESS. Most of the materials are common materials (light concrete, carbon steel, stainless steel) so we do not foresee an undue amount of production and installation risk.

There is an ongoing discussion about personal safety, positioning of switches and access schemes, which will have to evolve both with the ESS policy as well as the construction of the cave.

The common load spreading plate will allow ESTIA to load its large roof partially into the SKADI area, keeping at  $14 \text{ t/m}^2$ . There is no impact on functionality of shielding from that. This slightly impacted the schedule (4 month) but is not critical.

# Detector and detector tube

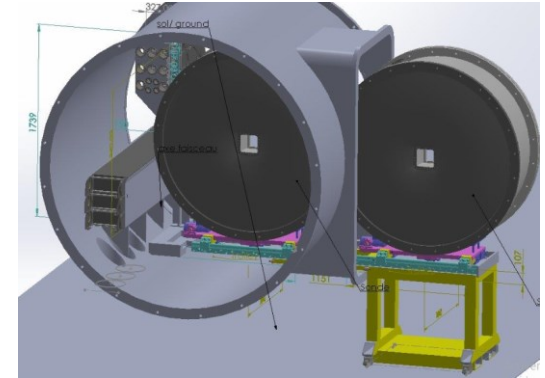
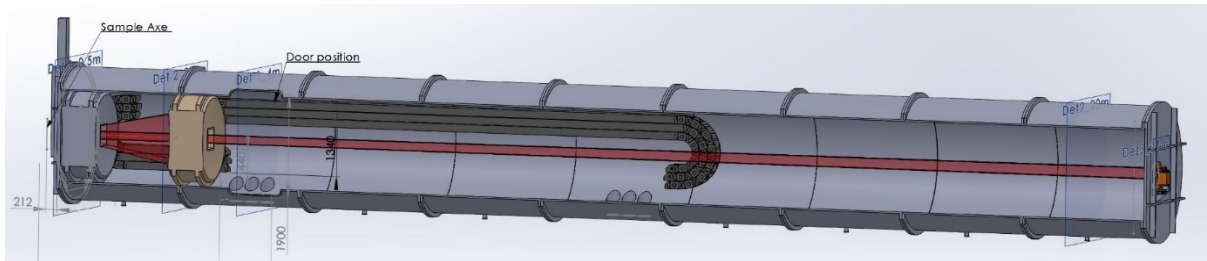

- Bids for contract for the tube are in, signature expected soon
- Detector electronics ready
- Detector housing partially constructed awaiting details of tube design

The design of the detector tube obviously strongly influences the design of the final parts of the detector housing (connectors) as well as that of the necessary maintenance equipment (frame to remove the detector from the tube).

This is taken into account and the final manufacturing of the detector housing is suspended until the TG3 acceptance of the detector tube has happened. This currently seems to be the case for mid 2022, which allows a detector installation in 2024 as foreseen.

Cooling is under testing.

DAQ testing is impacted both by lack of neutron facilities as well as software support on the ESS side.

# General Comments

Currently all major components are on track for a full instrument delivery end 2024, beginning 2025. There are no fundamental issues which would preclude that.

On a lesser scale, obviously a lot of detailed work has to be done, especially concerning installation coordination both centrally with ESS as well as other instruments, the load spreading plate between SKADI and ESTIA being only one example.

Another issue is the general communication with **ESS central facilities** for the installation of media supply (CUP) as well as electrical (CEP). The planning for a lot of components has advanced as far as final production or the last planning stages before that. Here clear communication is required, since without general media supply or the components cannot be cold commissioned. The installation as such seems not to be affected, since temporary installation (vacuum, water, electricity) are foreseen. The same is also true for software infrastructure, such detector software for testing.

A new PostDoc for the **development of the polarization analysis** has now started her position at ESS, so this will hopefully deliver a functional PA from day one.

The **general lack of neutrons** throughout Europe obviously impedes any neutronic tests (guides, detectors) but hopefully will be only short-lived. Some facilities are still running through the next year (ISIS, PSI, Budapest), but they will be severely overbooked.

# General Comments

At the current stage this is not worrying, but we will need to monitor is closely. Tests in 2023, perhaps even 2024, will be perfectly adequate for most of the neutronic components.

As a final remark, there was **no direct Covid impact** on the SKADI team. Some of the suppliers were affected, but also here mostly the availability (and cost) of components is a problem. Those issues seem to be possible to handle in all cases.

# Take Home

- All external components have been subcontracted/selection of contract winner is running now (sample cave, in-Bunker, collimation, detector tube)
- Manufacturing of dedicated components is already running
- Installation will start mid-2022 (NBOA, in-Bunker, bunkerwall, base plate for sample cave)
- Components to be manufactured internally are either already running (sample cave internals, detector) or already have the approval for manufacturing (choppers)
- Only some small late install components still awaiting detailed design or procurement (polarizer housing and sample shutter)
- Paper with details published:  
<https://doi.org/10.3390/app11083620>
- Complete installation until 2025 is completely feasible