

An update on detectors for STAP

30th September 2021

ESS Detector Group. Prepared by Ramsey Al Jebali, Richard Hall-Wilton.

Preparation for multi-grid pilot test at LET instrument

More details: <https://confluence.esss.lu.se/display/DG/Planning>

Two days of beamtime is confirmed for a pilot test at the LET instrument in the 21/02 run cycle, first run after the long shut down currently scheduled for the month of March 2022. Upon recommendations made by the MG.CSPEC project steering board and the CSPEC instrument team during a joint meeting held in May 2021, MG detector production has been put on hold until after results from the LET test are extracted. If detector production to commence in May 2022 it will still be possible to deliver all of the 18 detector modules before CSPEC instrument TG5 date.

For the LET test, work on building a shorter version of CSPEC instrument specific MG detector is on-going. The detector is significantly different to the previously tested device and will correspond as far as is possible to the final CSPEC design. It will have CSPEC grids design, optimised $^{10}\text{B}_4\text{C}$ thicknesses, detector internal shielding configuration, grids and wires signal transport layout, VMM based readout electronics, Standard readout chain, Event Formation Unit (EFU) and the CSPEC beam-dump detector vessel. Blades are carved from the same aluminium batch delivered for the MG detector production for CSPEC and TREX. Coating of these blades for the MG.LET has started in September 21, and will be finished by 8 October.

IDR for the CSPEC DETECTOR VESSEL & BELLOW INTERFACE DESIGN

More details at: <https://confluence.esss.lu.se/pages/viewpage.action?pageId=368431776>

Documentation exists for this review on the detector vessel and bellow interface design.

Key procurements for detector production

Radio-Pure Aluminium:

More details: <https://confluence.esss.lu.se/display/DG/Radio-pure+aluminium+SAT>

2 tonnes of radio-pure aluminium for CSPEC and TREX have been delivered to ESS between June and August 2021. Quality control and SAT were performed. GDMS elemental analysis and natural alpha activity measurement were done, confirming the contents of the aluminium alloy to meet the specifications. Details of the SAT results can be found in the confluence page above.

Sputtering Targets:

The procurement and delivery of 50kg of $^{10}\text{B}_4\text{C}$ from 3M has been completed. This is sufficient for all ESS instruments.

Delivery of 72x $^{10}\text{B}_4\text{C}$ targets for CSPEC, TREX, ESTIA and FREIA has started at a rate of 4 targets per month. First 8 targets have already been received at the Linköping coating facility in September 21.

RD51 Hybrid production:

Procurement for the 25 silicon wafers for the VMM chip production started. PO sent to company, and order is accepted by the silicon foundry. Despite the ongoing global silicon foundry crisis, it looks like the production run will be early next year. This means that it should be possible to receive the chips before next summer, and no schedule pressure will result from this.

First batch (270) of series 7 FPGA VMM hybrid production started: PO issued to company. Prior to the order, the design was determined to be valid & Firmware runs on the hybrid. Delivery expected next year. Schedule pressure unlikely.

Status of the Readout Electronics

More details on the status of this can be found in the IKON21 talks: <https://indico.esss.lu.se/event/2807/contributions/14605/>

The diagram of the readout chain for MultiGrid (and MultiBlade, which is identical) is shown below in the figure below.

The backend readout has been demonstrated to function well with the LOKI readout chain, showing end-end data from neutrons on the EMMA beamline at ISIS. The BIFROST readout will use the same front-end digitisation modules as LOKI. This will also be the same for MIRACLES and probably VESPA too. Therefore, the demonstration of the data chain with LOKI also represents a demonstration of the BIFROST readout chain.

The readout hardware is being procured by BIFROST currently and is expected somewhere at the end of this year (pending developments in silicon crisis related delays). This would allow a similar end-end test. The detector group has a similar module available from LOKI, that could be used for any needed tests that take place in Lund. Discussions have taken place between all parties (BIFROST team, ILL, CAEN, Nuclear Instruments, detector and ECDC group) and a detailed understanding of the BIFROST detector and DAQ chain exists.

An ICD for the VMM data format has been agreed between detector and ECDC groups. This covers in particular the data definition between the backend master module and the event formation unit.

End-end data has been seen from the input to the VMM chip through to the EFU (i.e. through the Assistor, through the rings, through master module and to the EFU). Rigorous checks are ongoing though the final link between VMM and the assistor firmware. ESS facility timing is implemented and propagated to the front end assistors as expected. This now includes testing back to the ESS master source of timing, the "EVG"- i.e. event generator. An embedded receiver of this timing has been implemented on the backend master module.

6 pre-production Master Modules have been built. Production of the remaining master modules for all instruments is imminent - pending final signoff on the electrical documents and a review. All of the Master Modules should be available by early 2022, ahead of when they are needed. For the pre-production modules, 1 has been set aside for the LET test and 1 has been set aside for the AMOR test. This pre-production module will be available for MultiGrid testing from now on.

The work on the VMM readout integration will be initially demonstrated with the MultiBlade detector, where a detector is being built for the AMOR instrument at PSI. The hot

commissioning tests of this detector start in December 2021. The results of this integration are directly transferable to the LET tests - and CSPEC and TREX thereafter.

A key part which has been slow progress on electronics over the past years has been available personnel, which has been at the 1 FTE for all detector electronics activities. An electronics hardware expert will join the detector group on 1 November. For a second position, a candidate has been found and this is pending COVID travel rules to proceed with making an offer. It is also expected that the in-kind agreement with STFC/RAL-TD will be extended. This is expected to speed up progress in the coming months.

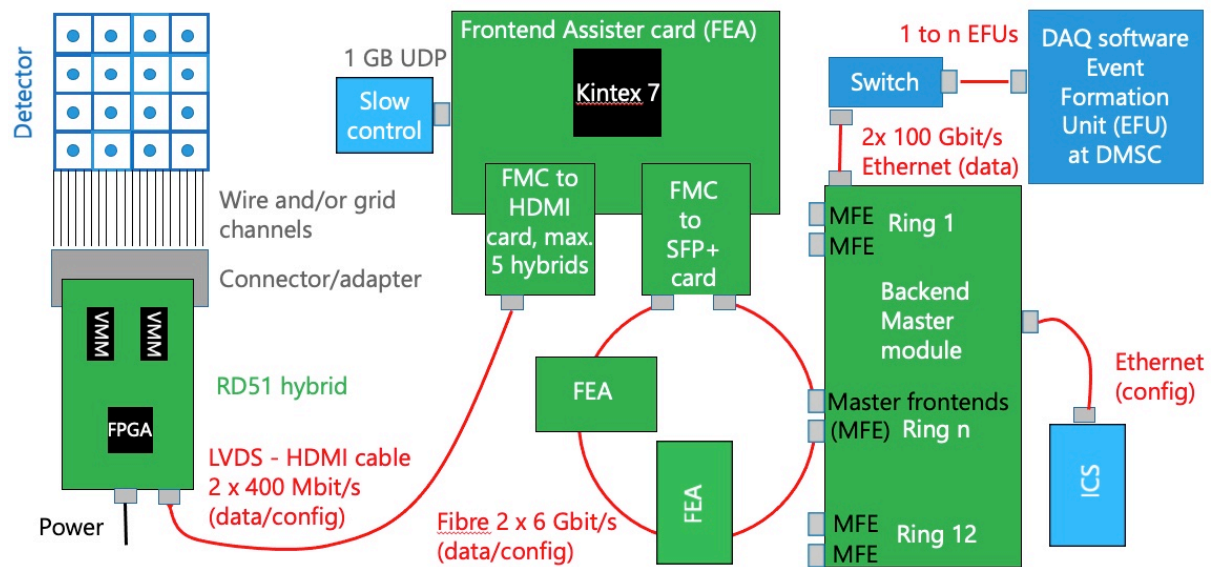

Figure 1 Readout chain

TREX Status

The grids for the mechanical demonstrator for TREX have been coated and built. This is 1 column of the TREX design. These have been done with regular aluminium and unenriched B4C. This is ready for a trial assembly when the detector vessel prototype exists. The interface between the columns and the vessel has been discussed and agreed.