



**EUROPEAN
SPALLATION
SOURCE**



Commissioning Workshop ESS-JPARC

ESS's commissioning plan of Target-Moderator system

PRESENTED BY JAIME ARRIAGADA – TARGET TEST & COMMISSIONING LEAD

2022-10-10



Agenda

- 1 introduction
- 2 Way of Working
- 3 Testing schedule
- 4 What's done so far
- 5 Next coming activities
- 6 Summary
- 7 Questions

1. Introduction



Target Station is one of the three technical components of ESS



1. Introduction



Target Station is one of the three technical components of ESS

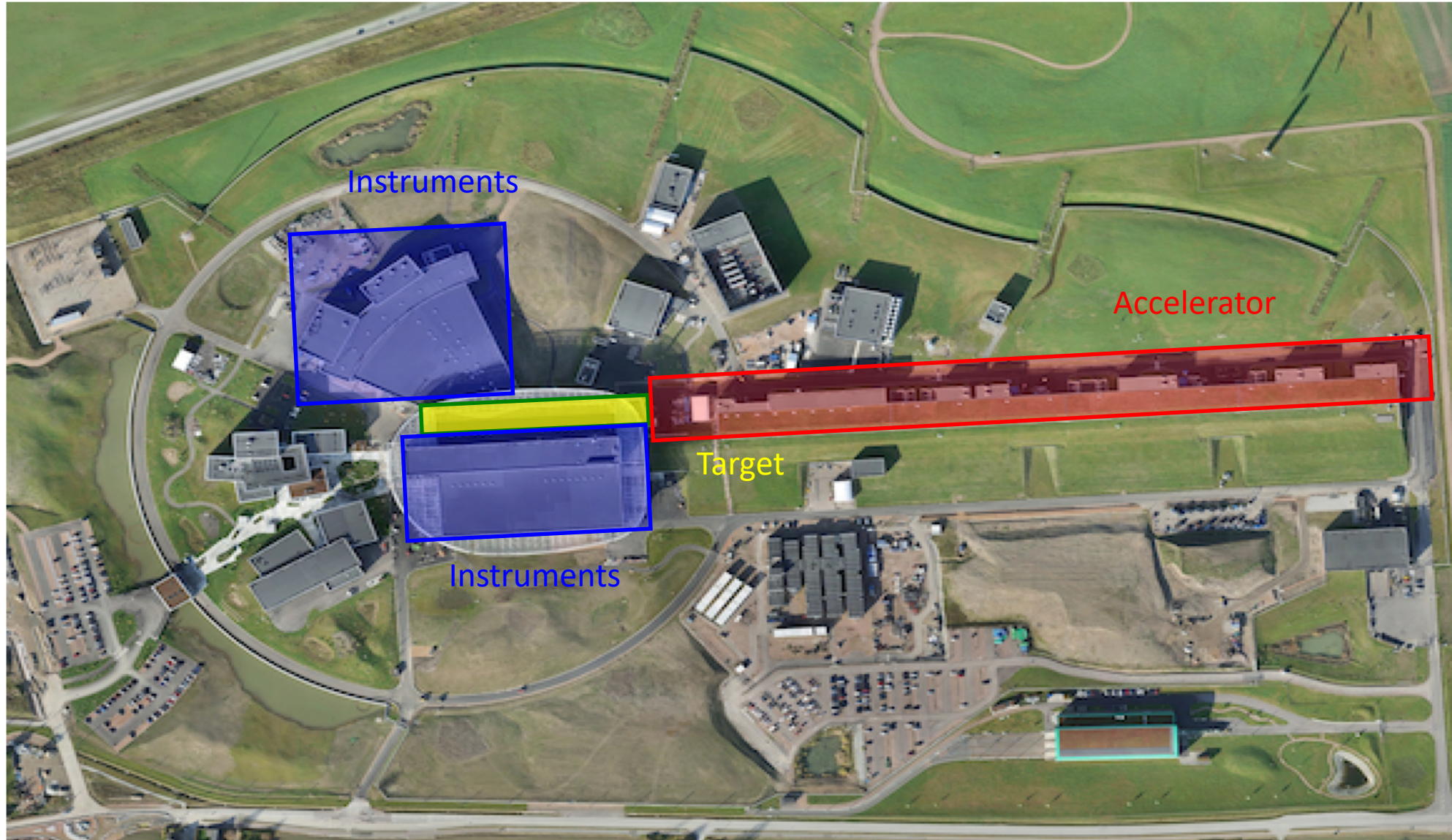

1. Introduction



Target Station high level functions:

- Generate neutrons via spallation by protons from the accelerator.
- Moderate and release the neutrons at speeds useful for the neutron instruments.
- Safe operation with high availability.

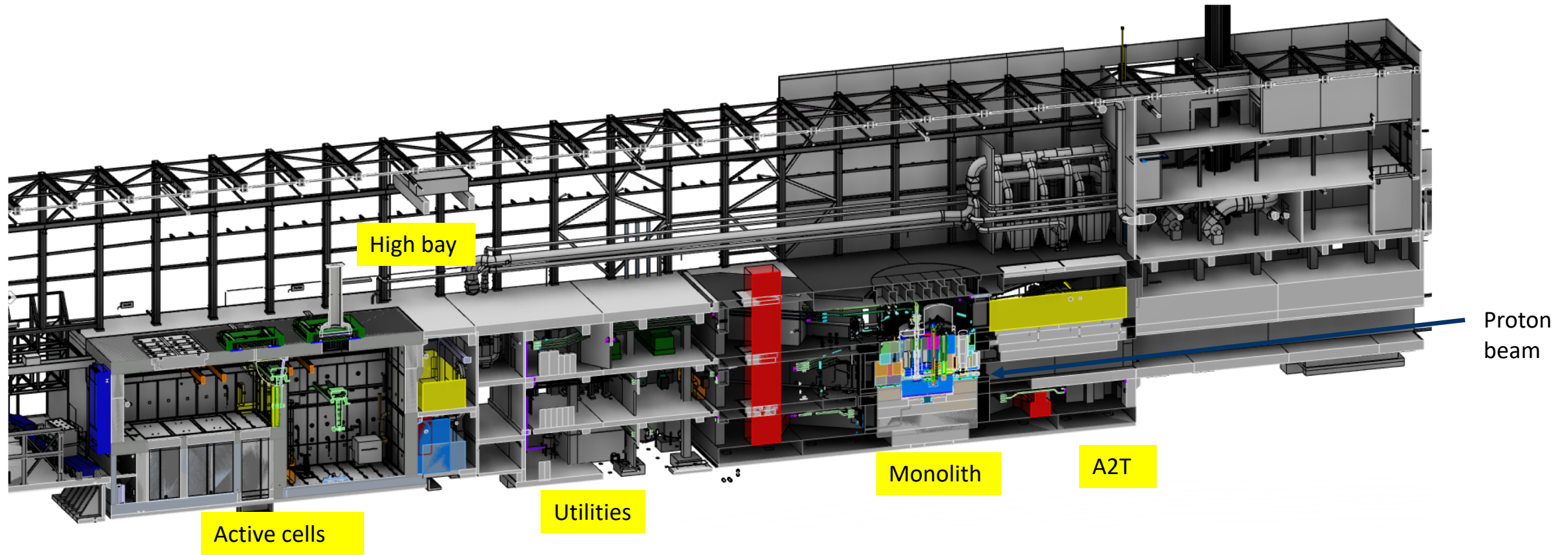

2. Way of Working (WoW)

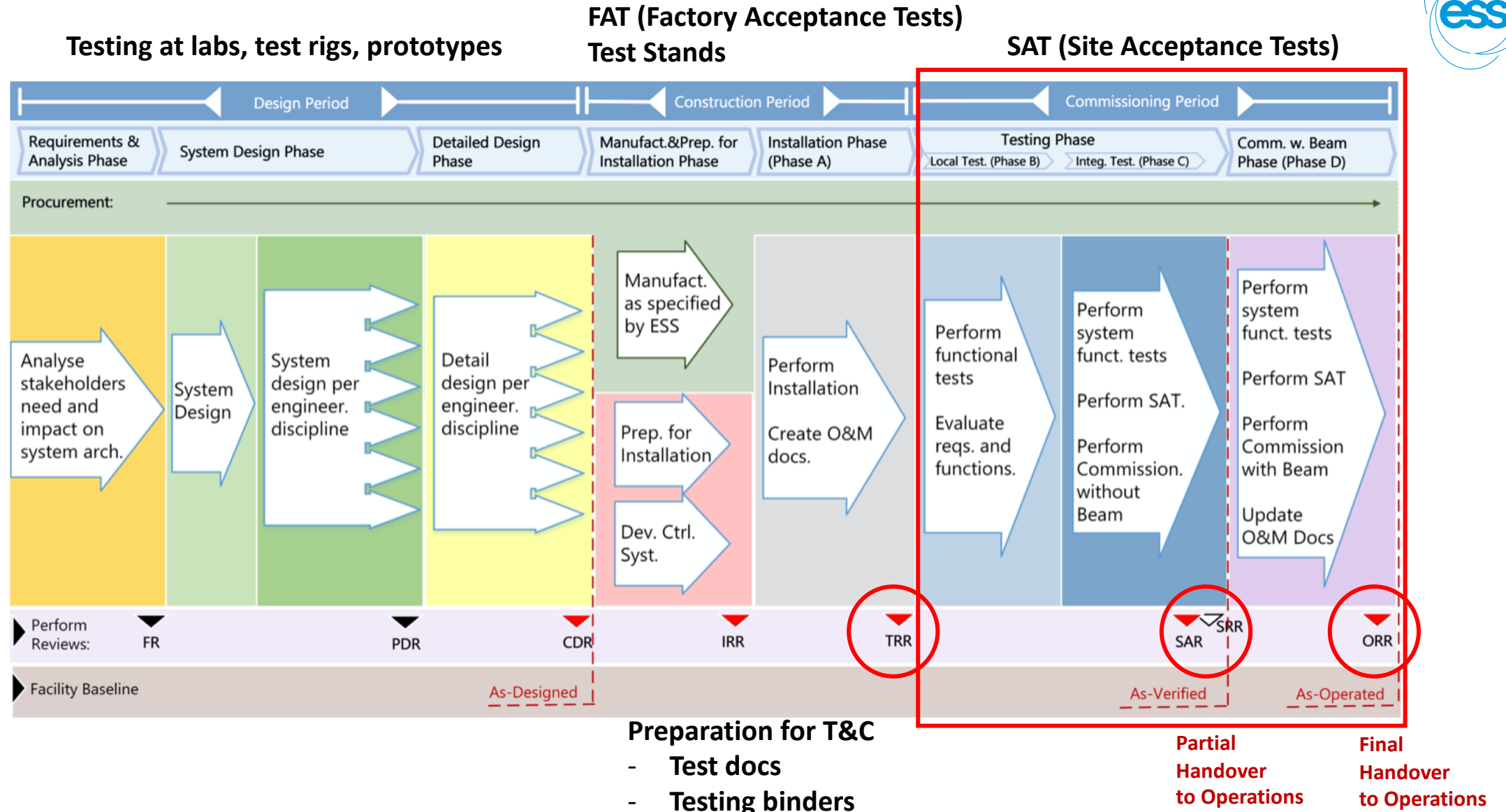

How to implement this "theoretical" WoW to an On-site organization?

2. Way of Working – Site organization

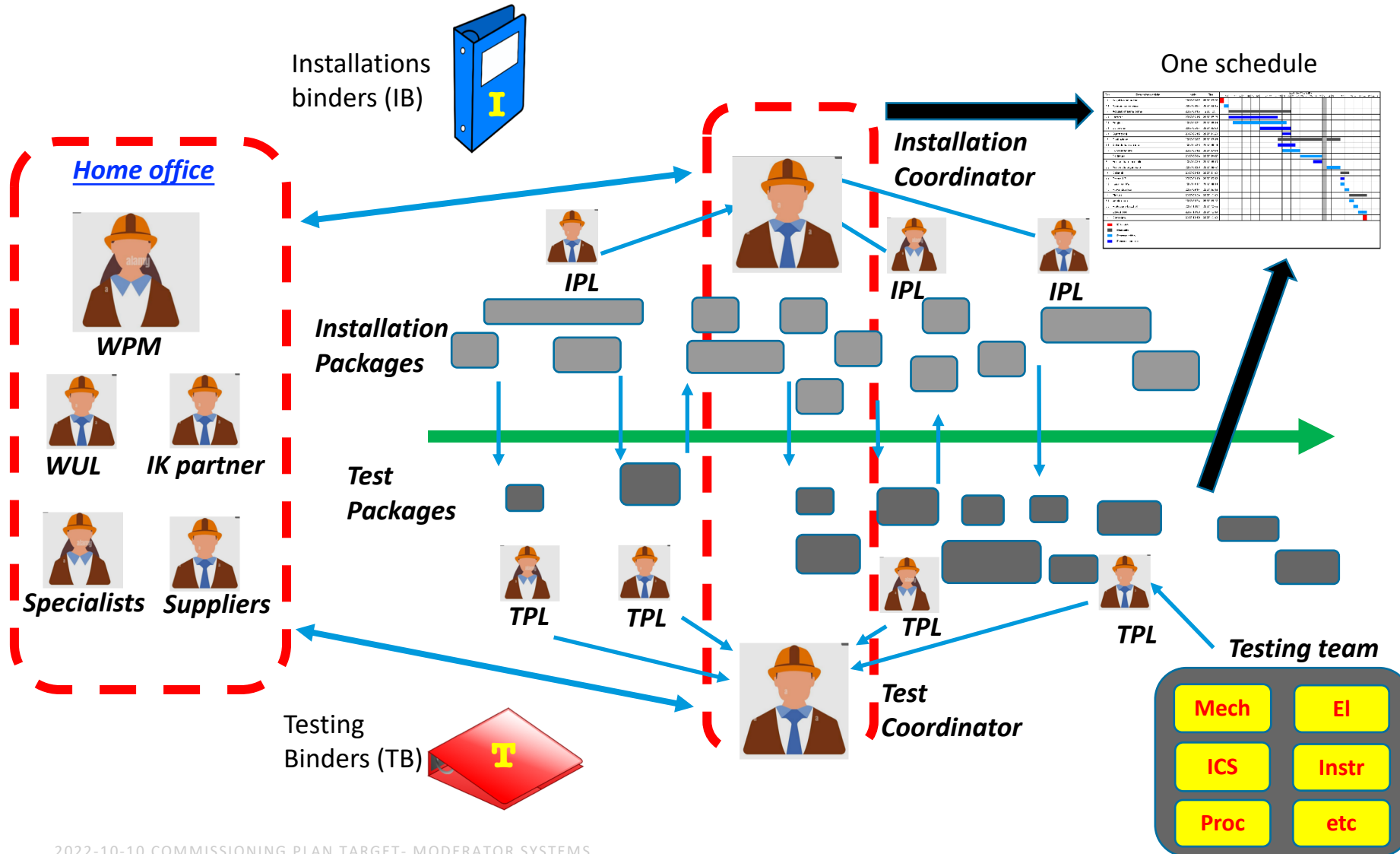

Test packages is “lagom” size.

Information gathered in TB’s.

Installation & testing at the same Time => Coordination of all site activities in D02 building. => One schedule.

No parallel organizations. Test and Commissioning is taking advantage of the synergies of the existing Installation Organization:

- One Area Coordinator who understands and evaluates risks.
- One electrical coordinator.
- Close collaboration with ICS (one testing team)

2. Way of Working – practical approach



Testing in lab B02:

- ✓ Test of LSS Frames in Vertical Handling Test Stand
- ✓ Drive Unit Test
- ✓ Drying System Test
- NBW Vacuum Tests
- NBEX Helium atmosphere

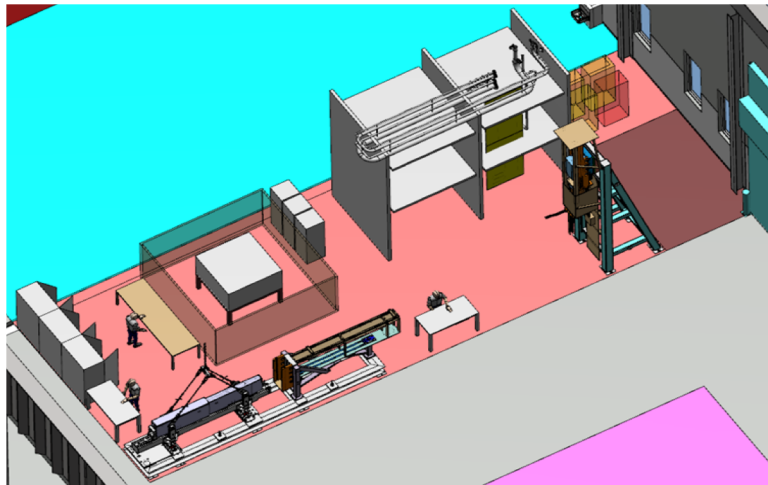

Marc Kickulies

**Marc Kickulies – Moderator
TUE 11:30-11:50**

Ulf Odén



**Ulf Odén – target Systems
TUE 14:00-14:20**

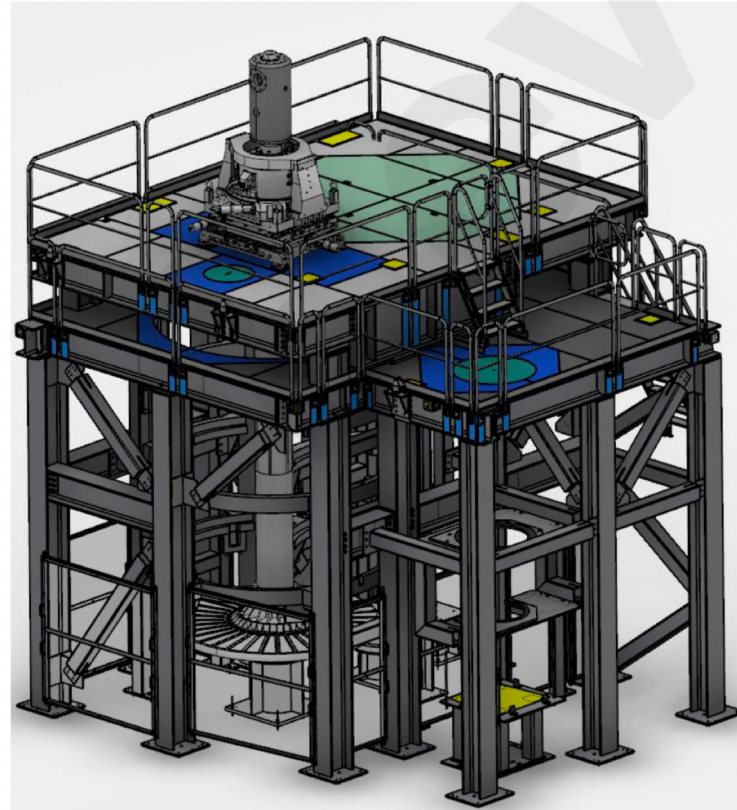

Test stands: e.g. TRIM (Target division Ready for Installation in Monolith Vessel)

- ✓ Installation findings
- Proposed changes to the installation procedures
- Rework to optimize installation
- Test results
- Tests just possible to verify in the MUTS
- Proposed changes to final tests in the monolith vessel

- ✓ Alignment table for Neutron Beam Optic Assemblies in experimental hall E01:

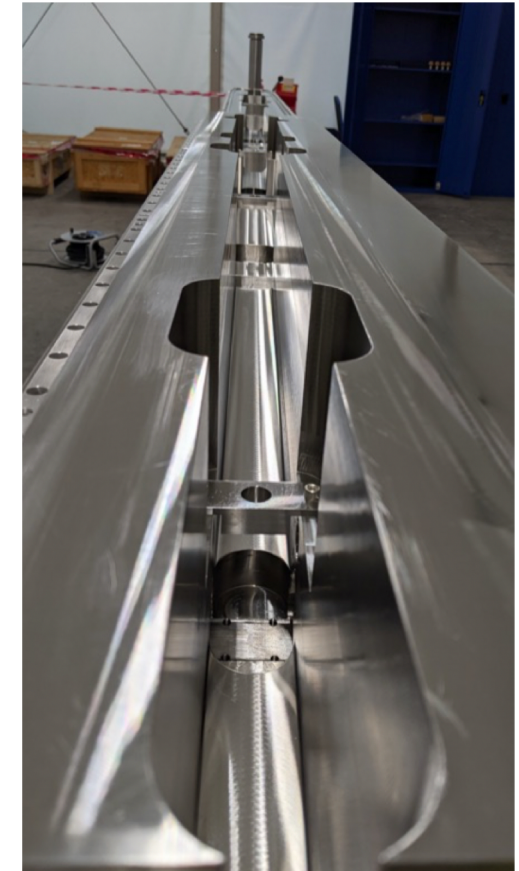

2. Way of Working – practical approach

- Testing in *Bypass* mode: without connection cell installations finished.

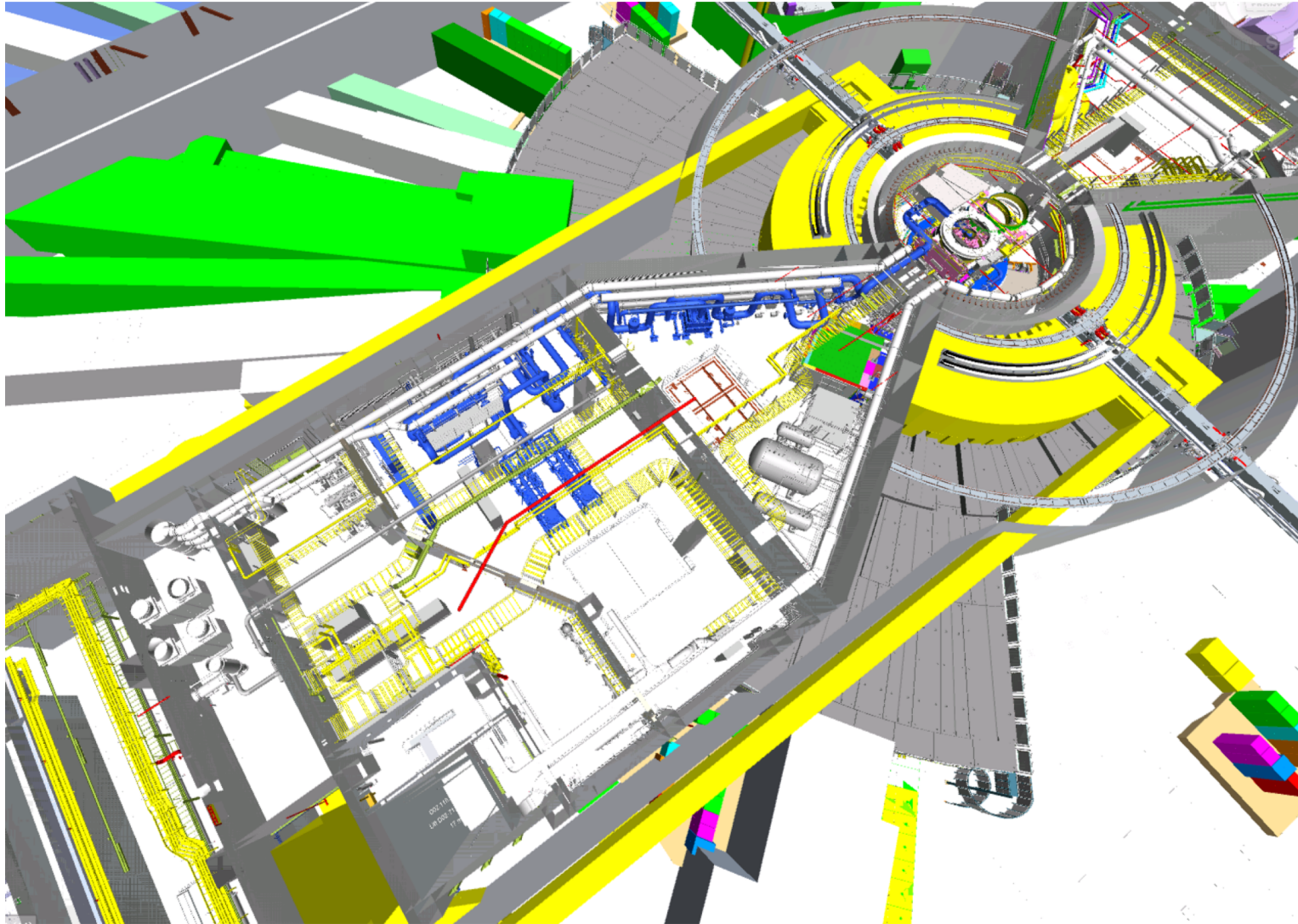

3. Testing plan – mapping of system dependencies



Target Group system testing

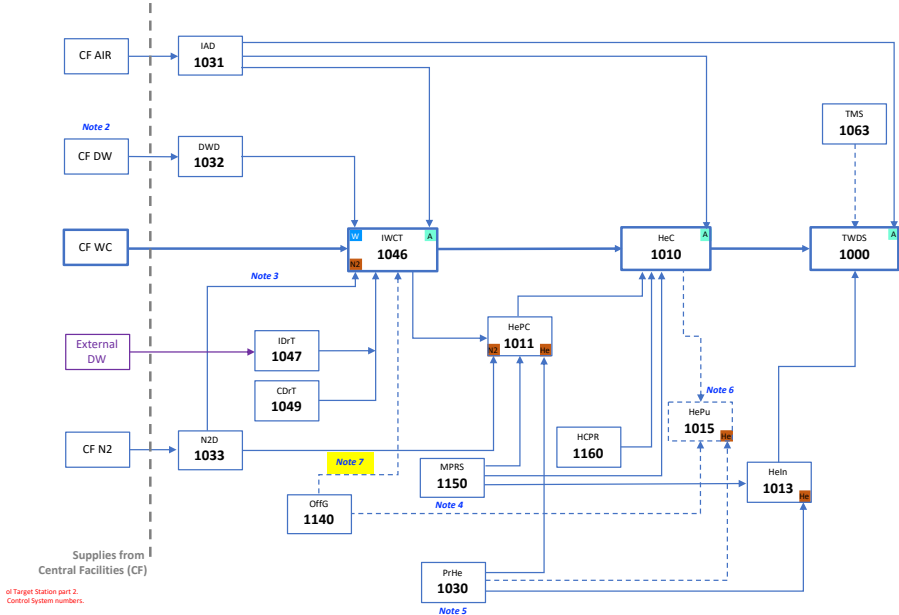

Supplies from Central Facilities (CF)
 @ Target Station part 2
 Control System numbers

Moderator Group system tests

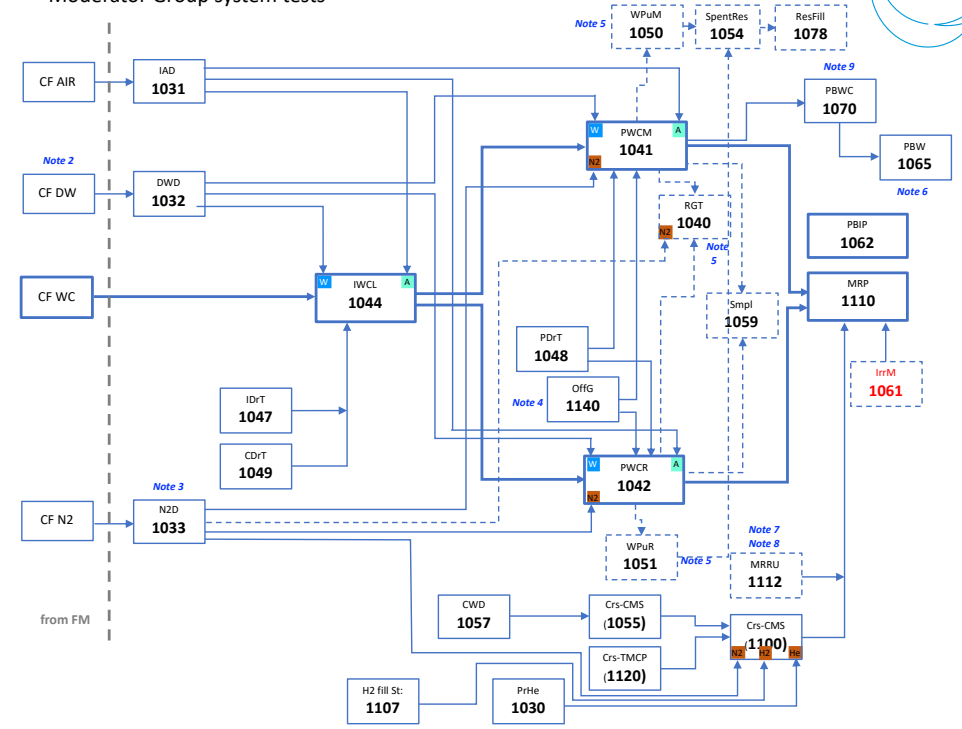

Monolith Group system testing

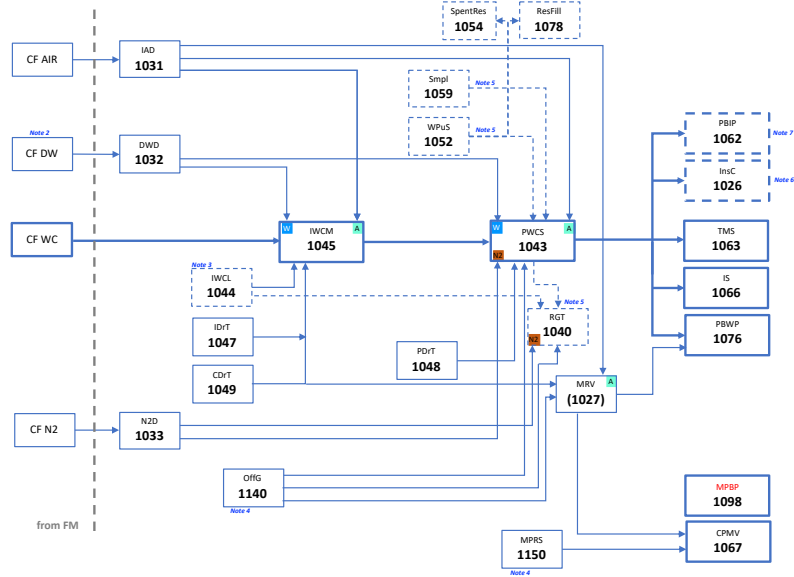

3. Testing plan – implementation of the schedule

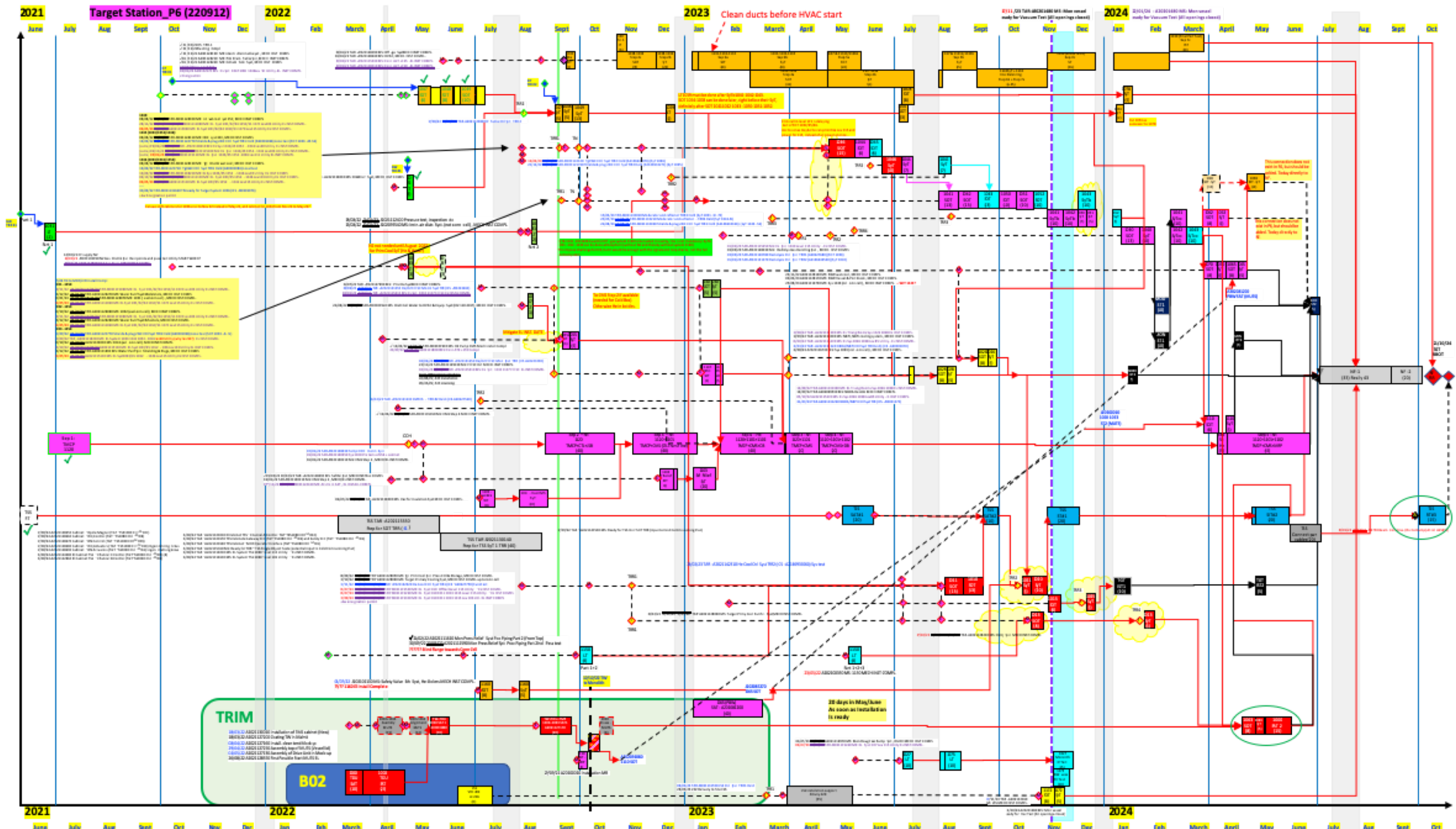

3. Testing schedule – grouping of activities in parallel teams

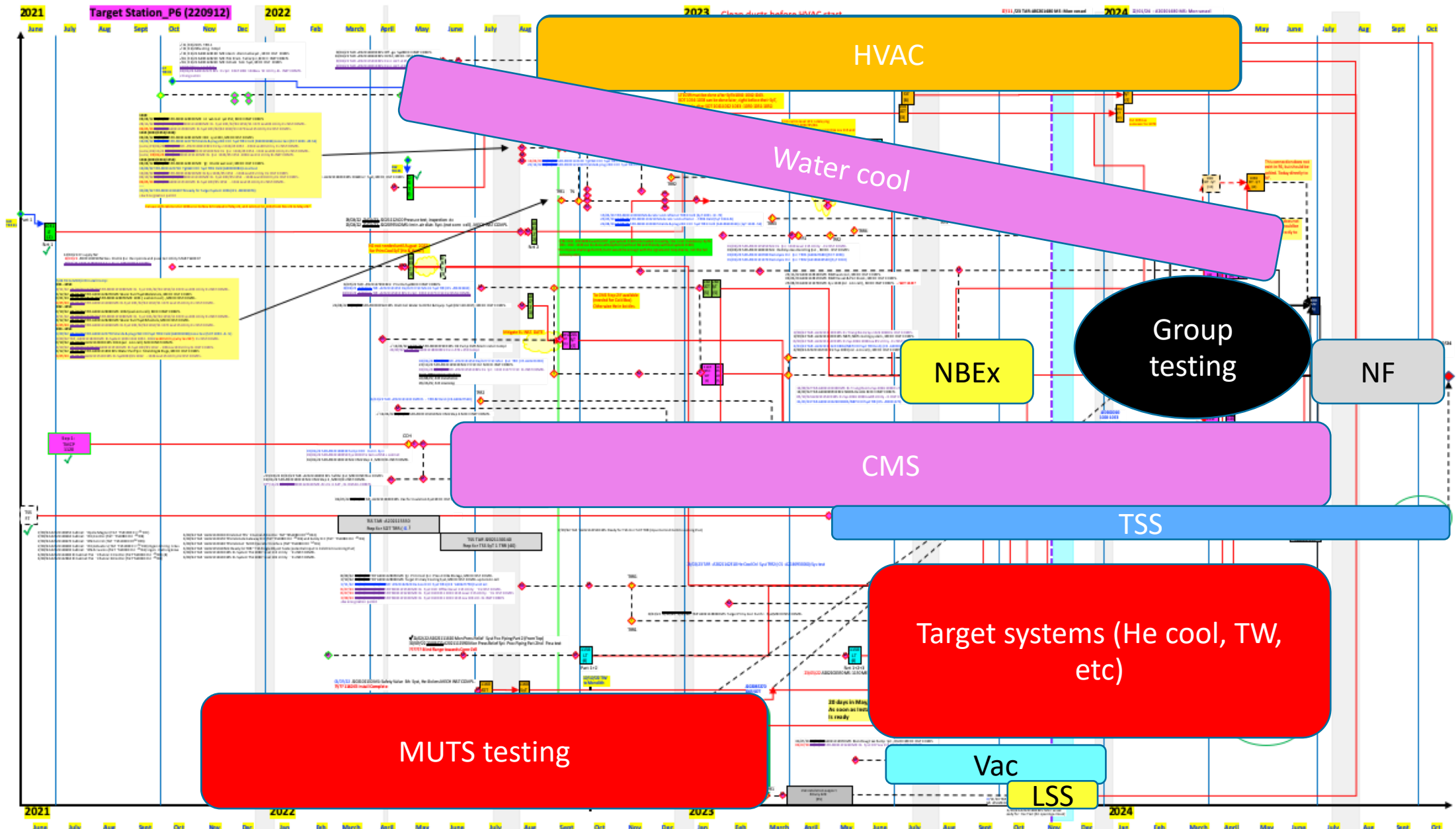

3. Testing schedule – verification and safety

SAR ACF + SAR CA

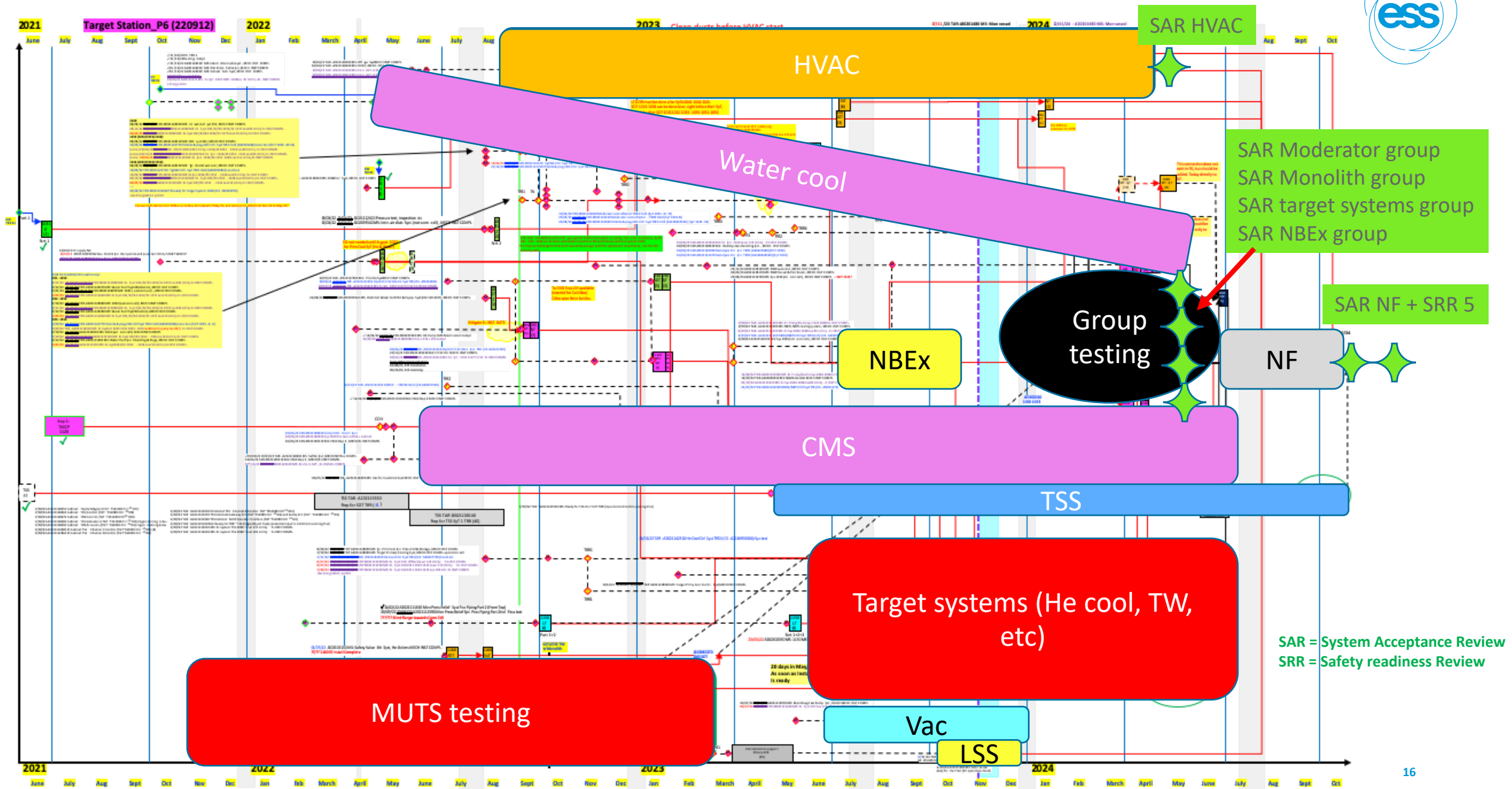

SAR = System Acceptance Review
SRR = Safety readiness Review

4. What's done so far - ACF



Cross-Section of the ESS Active Cells

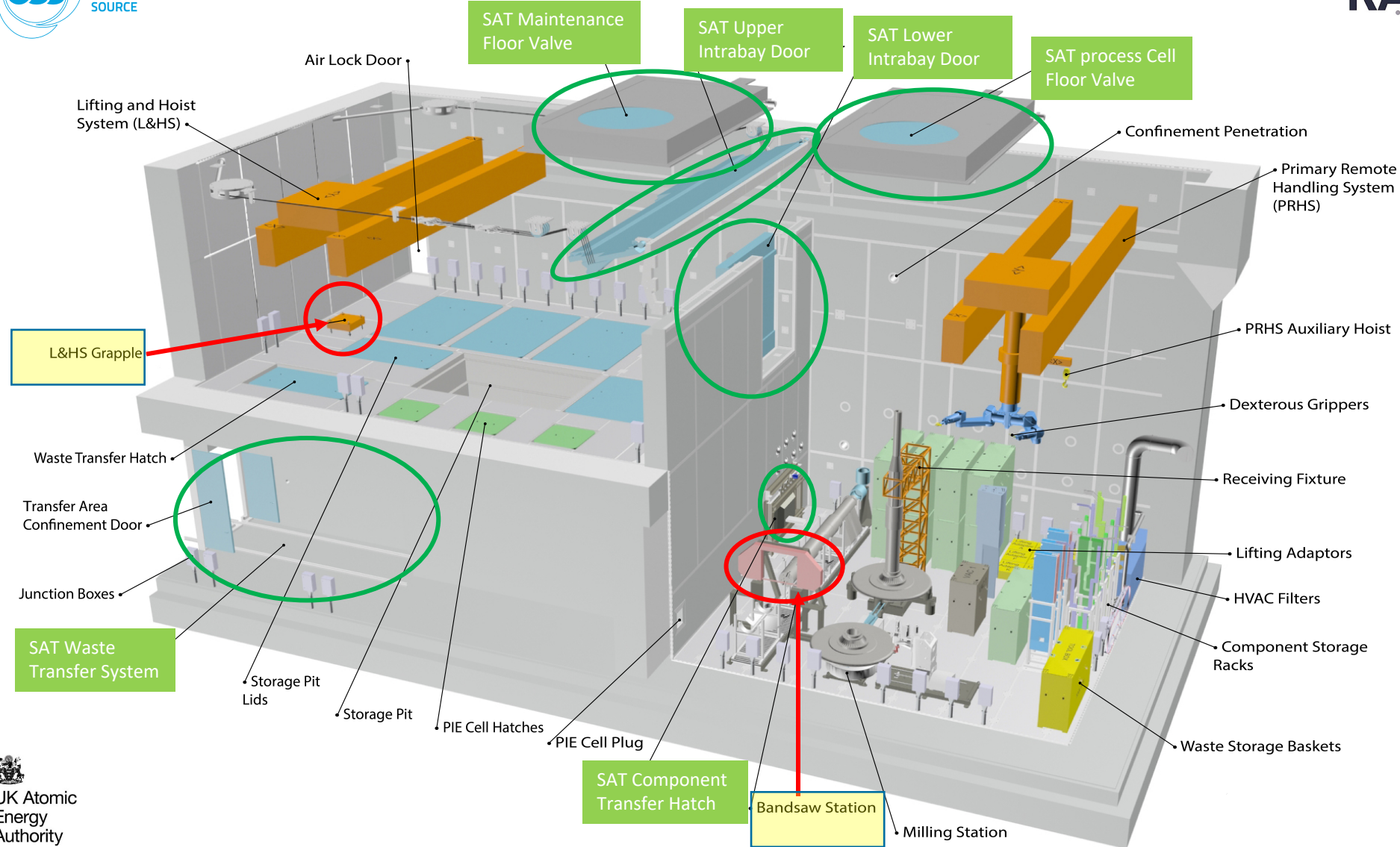

24/08/2017

4. What's done so far - CMS

STEP 2 with He going on, 33% done:

✓ Verification of the CTL and JSB.

Left to be done:

- Optimization of the cooldown and warm up Operation.
- Tune in of the system parameters with a simulated heat load.



CMS is cooled by the Target Moderator Cryoplant (TMCP)

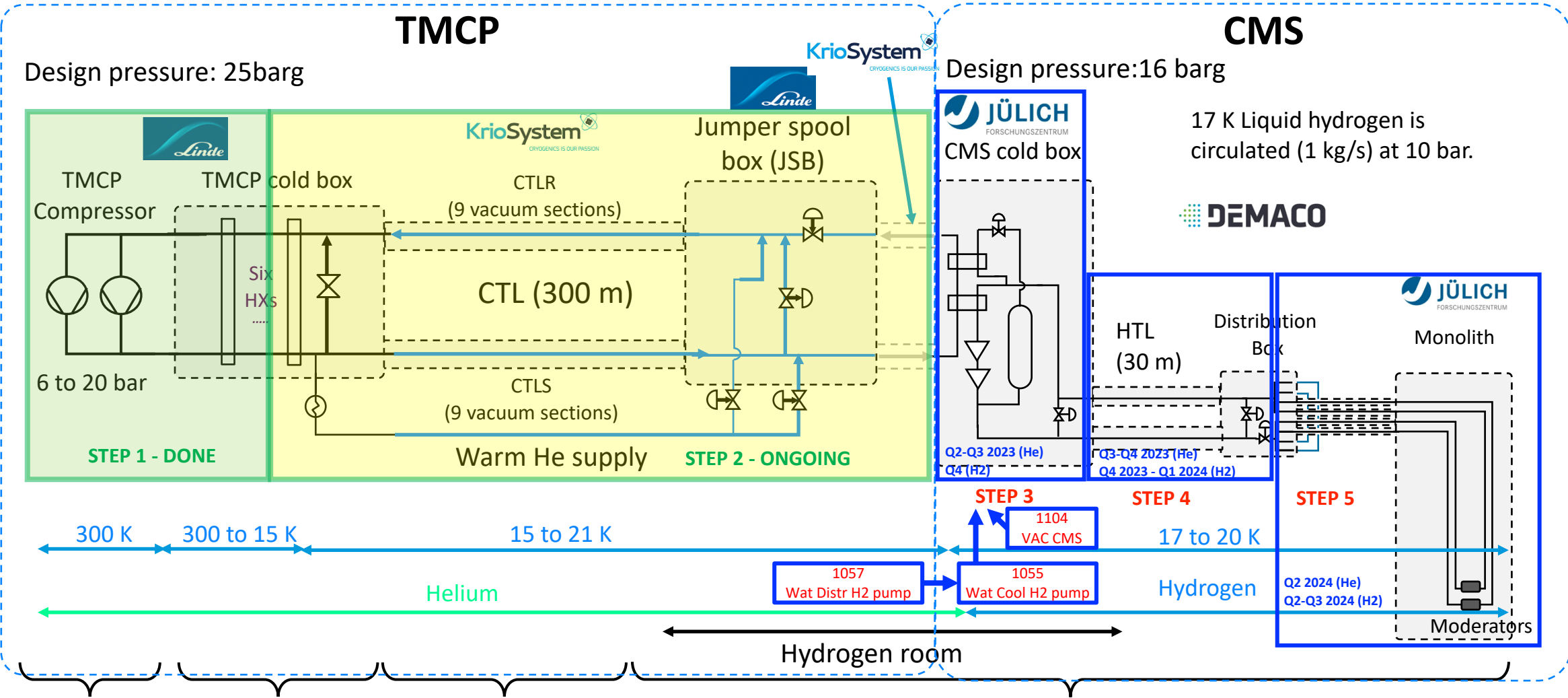

GO4 Target Compressor Hall G02 Cold box Hall Below grade duct (CTL Trench) D02 Target building

4. What's done so far - Utilities

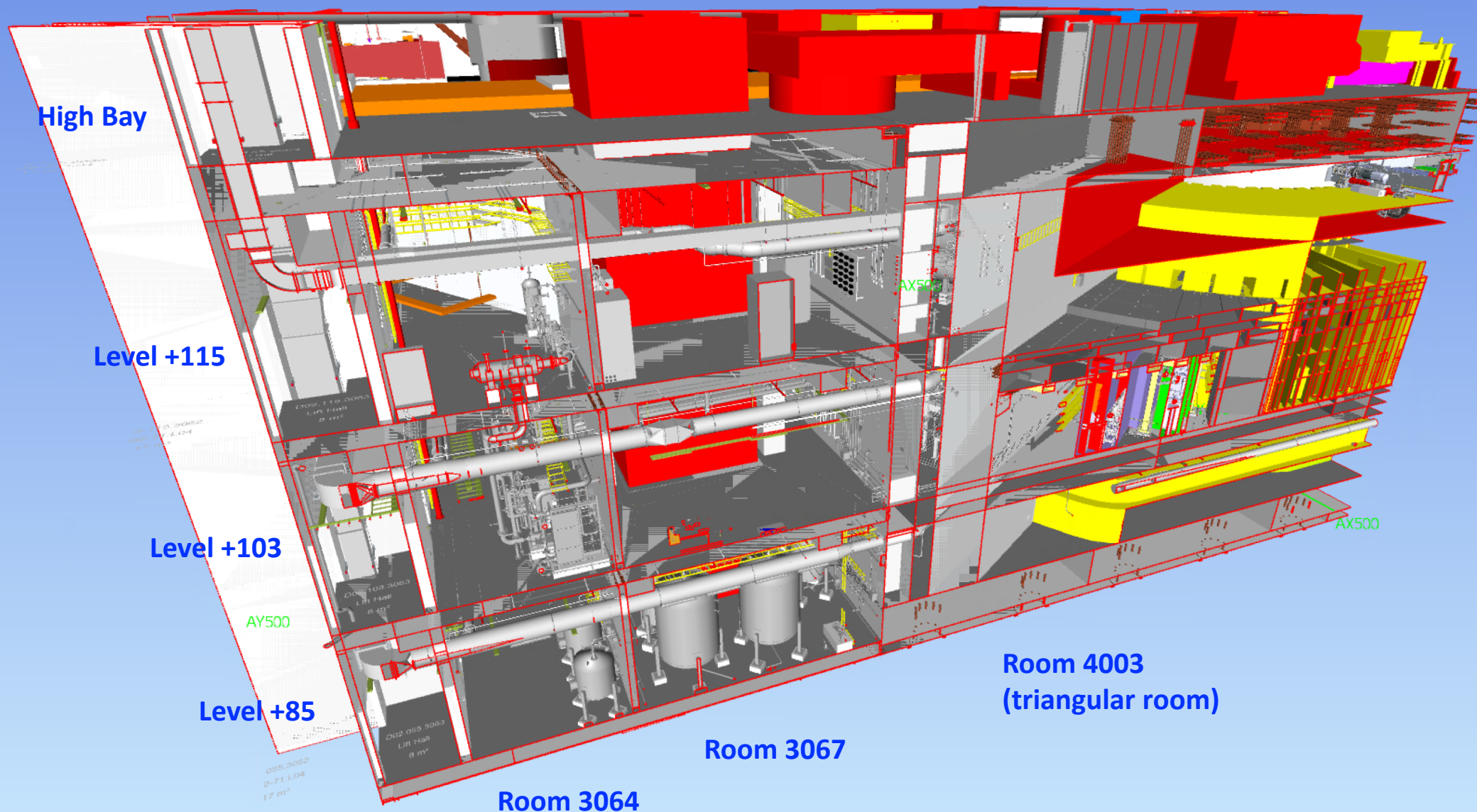

4. What's done so far - Utilities

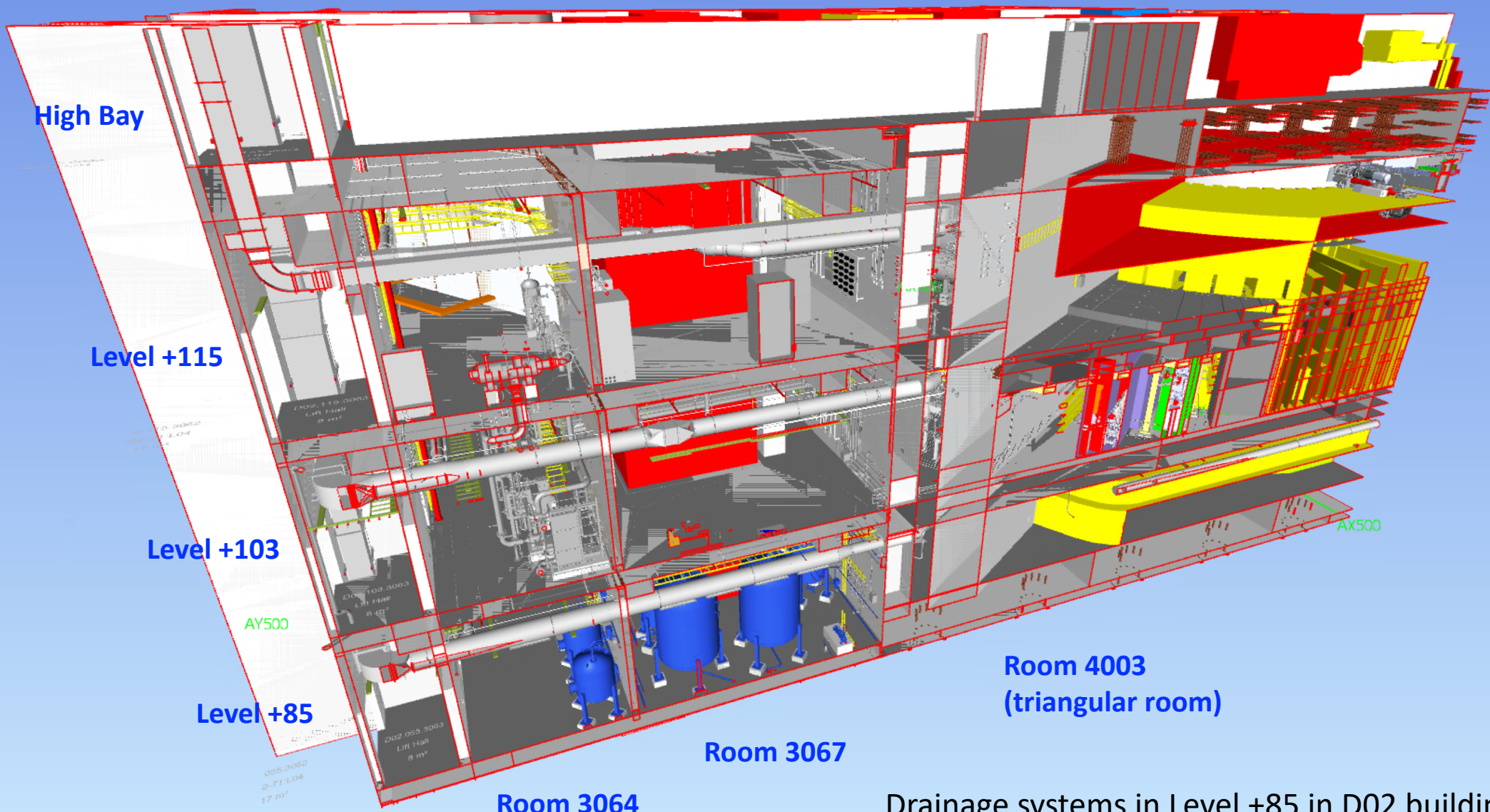

Drainage systems in Level +85 in D02 building
Systems 1047-1048-1049

4. What's done so far - Utilities



Drainage systems in Level +85 in D02 building:

- ✓ Single Objects Tests 1047
- ✓ Single Objects Tests 1048
- ✓ Single Objects Tests 1049
- ✓ System Tests 1047
- ✓ System Tests 1048
- System Tests 1049 => ongoing

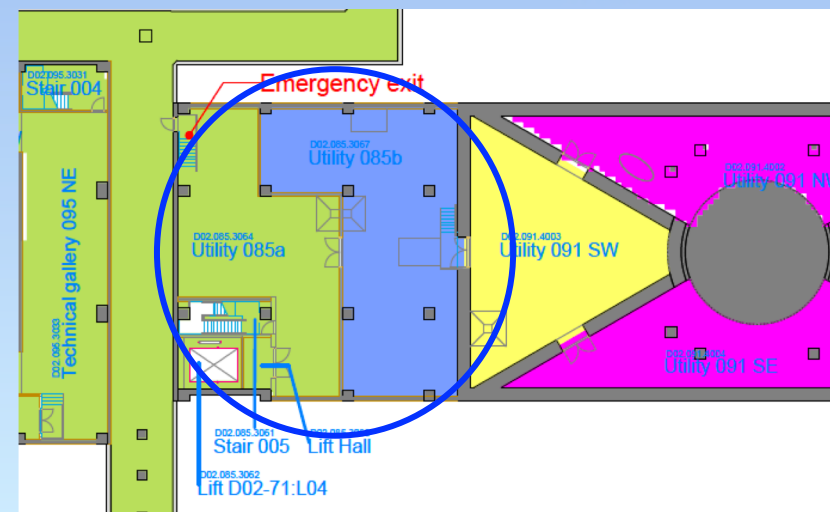
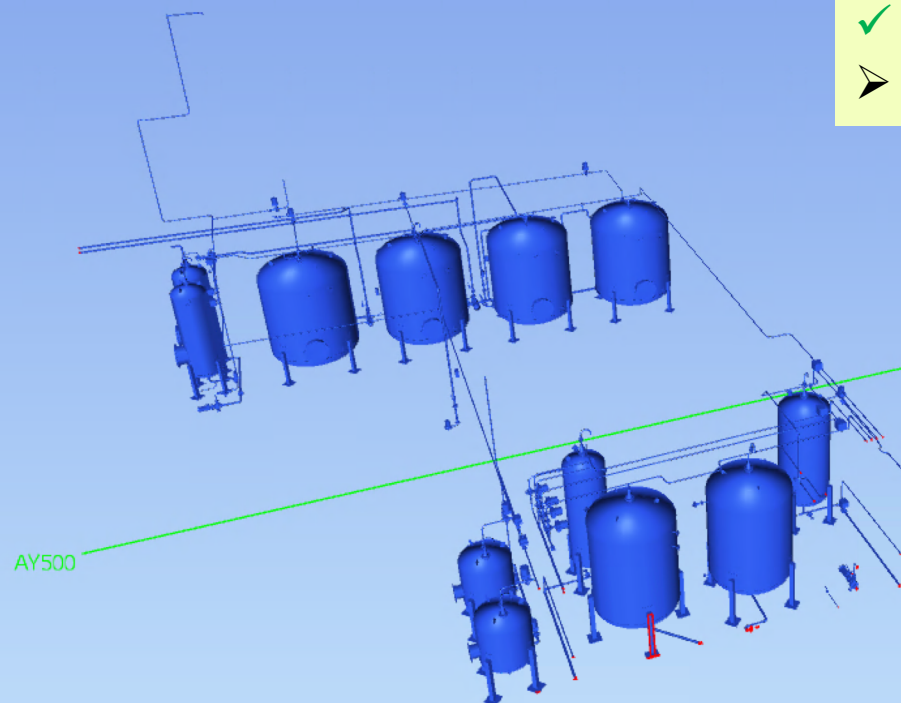

4. What's done so far – Target Wheel at MUTS



Cooling by Helium gas
11 bar, 40-230 C, design 3 kg/s

36 sectors
186 Tungsten blocks / sector
3 tons Tungsten
23,333 RPM rotational speed

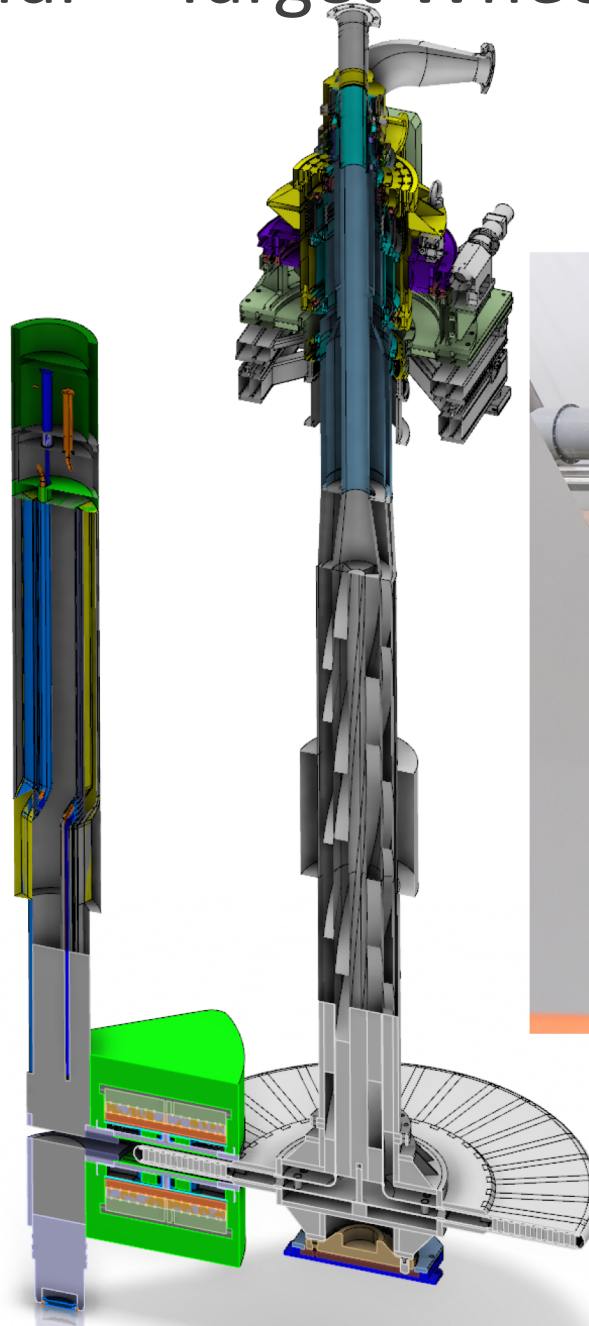
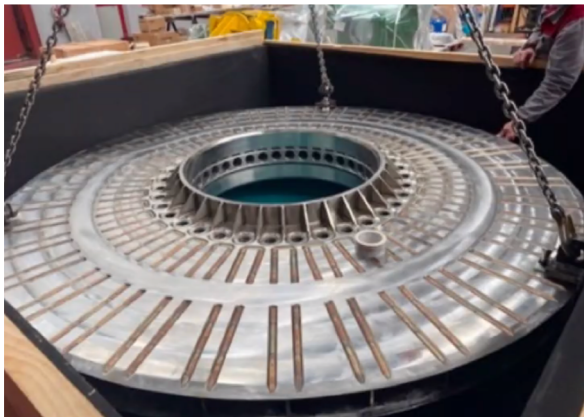
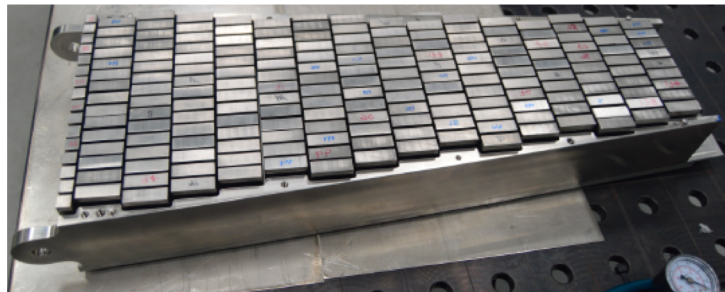

Already in the MUTS => testing ongoing



In-Kind: ESS-Bilbao (ES)

4. What's done so far – Other support systems



- Deionized Water Distribution in D02 building and integration with FM supply system -> DONE
- Instrument Air Distribution in D02 building and integration with FM supply system -> DONE

4. What's done so far – Other test rigs



The **Drying Ssystem** has been tested in the test rig in building E02.

The aim of this system is to improve the drying of the water systems from radioactive water, for improving the safety during maintenance operations.

The tests in the test rig showed that:

After draining the water to the Drainage Tanks in level +085 it is possible to suction remaining water with the Drying system if a certain under pressure is first created.

The remaining water droplets can be eliminated with the vacuum system.

The humidity degree in the piping can be monitored with dew point measurement and pressure measurement.

5. Next coming testing activities - Highlights



- ACF: SAT wire cutting station & grapple crane
- Utilities: Single Objects Tests on Intermediate Water Systems
- CMS: continue with the step 2 of the commissioning plan for CMS
- MUTS: “24/7” running test on Target Wheel in November/December.
- HVAC: start preparations for commissioning
- Worries for failure of key components that impact on the testing and commissioning schedule and execution.
- Alignment of the commissioning plans for the whole ESS ongoing (integrated commissioning)

6 Summary

- The engineering flow implies a WoW where testing has been present all the way, not only during testing phase.
- Site organization synergies, close collaboration with Installation. One schedule. Support from IPL. Close collaboration with ICS, one testing team.
- Test stands, MUTS, help us optimize the installation and testing. Decrease uncertainties and risks.
- Testing and commissioning of some systems ongoing:
 - SAT's for several parts in Active Cell Facilities
 - Cryogenic Moderator System (CMS) Step 2 with Helium.
 - Drainage Tanks Systems in Utility rooms in level +085.
 - Distributions systems such as Deionized water and Instrument air.
- Worries for the late problems with key components and how this will affect the commissioning execution.

7 Questions