



Science and  
Technology  
Facilities Council



EUROPEAN  
SPALLATION  
SOURCE

# Freia STAP Update

Jon Elmer, Tom Arnold

October 2022

# Schedule

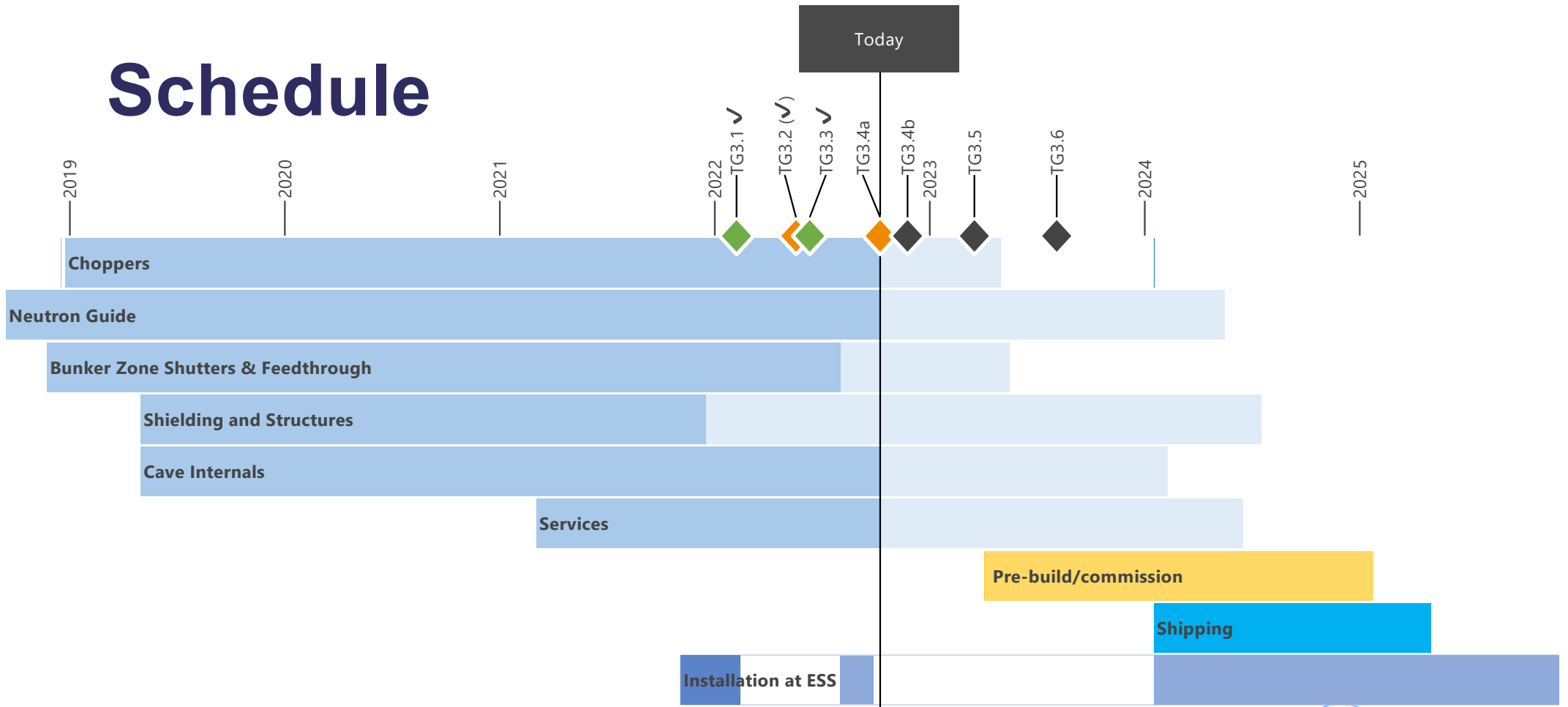

# Design progress summary for 2022

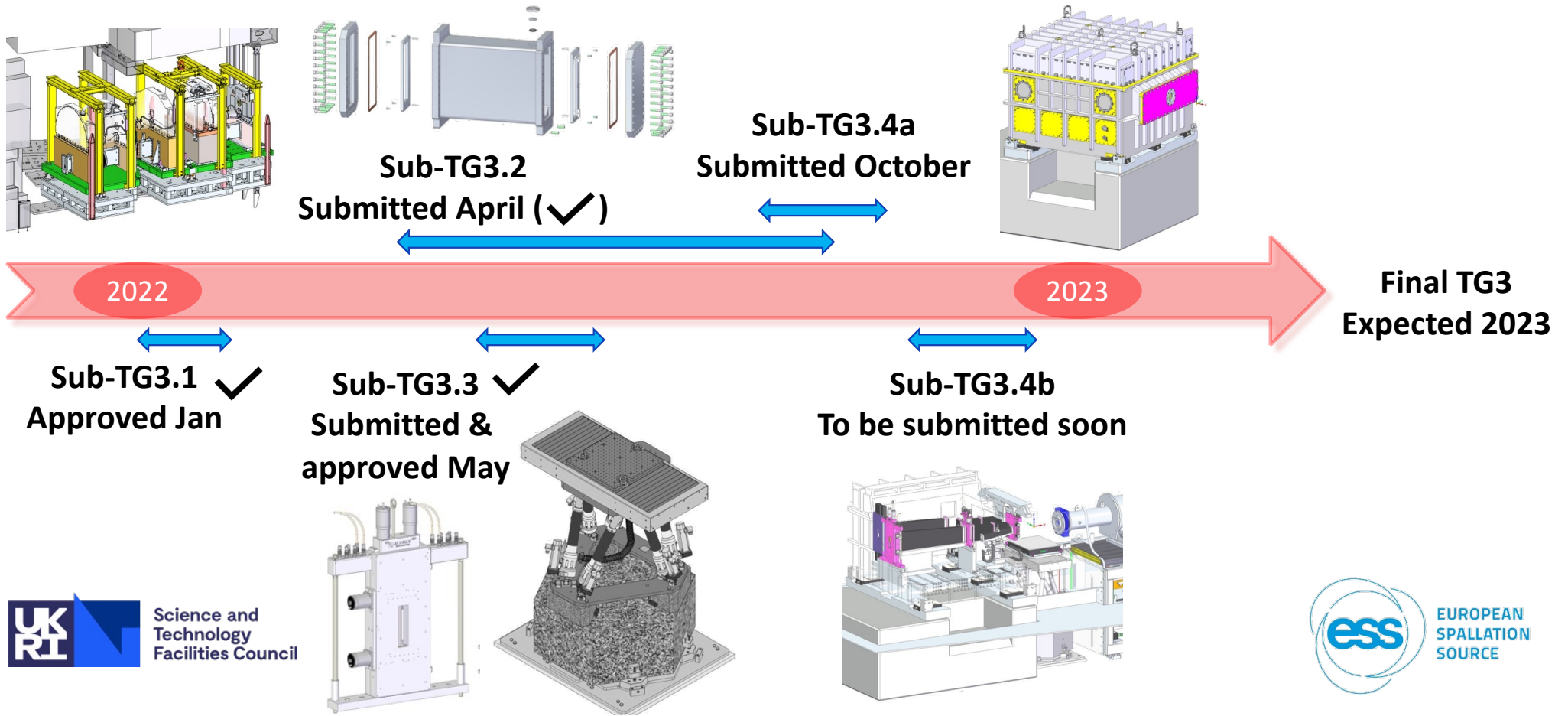

# Sub-TG 3 Summary

- Sub-TG 3.2 submitted in April, changes to be implemented
  - Bunker Modules, Light Shutter vacuum housing, In-bunker chopper housings, Bunker Wall Feedthrough
- Sub-TG 3.3 passed in May
  - Slits, Sample Positioning System
- Sub-TG 3.4a submitted in October
  - Collimation vacuum housing
- Sub-TG 3.4b to be submitted in 22Q4
  - Collimation translation stages, detector positioning system

# FREIA

**Guide (SNAG)**  
In manufacture

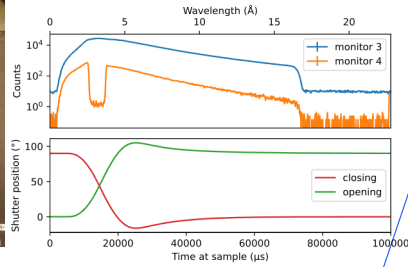
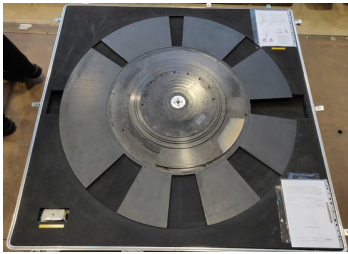

**Fast Shutter Prototype (UU)**  
ZOOM tests complete ✓  
Progressing with final design

**Collimation Vacuum Vessel (AVS)**  
CDR Complete ✓  
TG3 in October

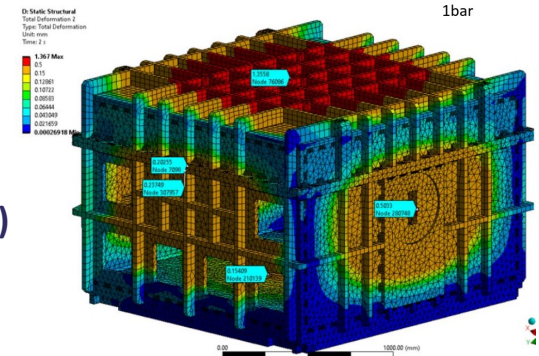

**Heavy Shutter**  
Neutronics underway

**Chopper Discs (ADSF)**  
Delivered to RAL ✓

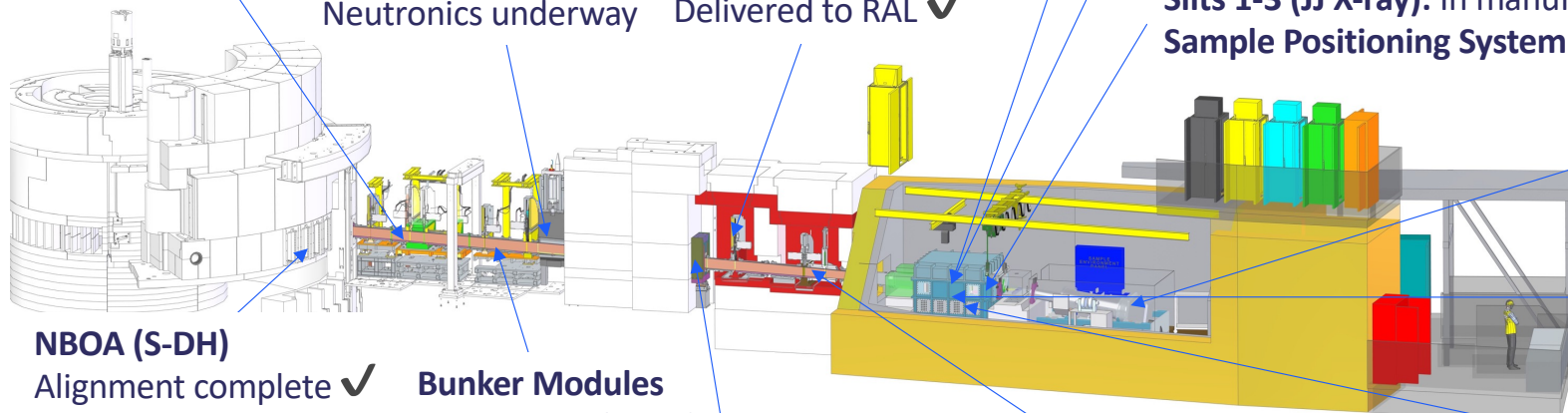

**Slits 1-3 (JJ X-ray):** In manufacture, blades ordered.  
**Sample Positioning System (Symmetrie):** In manufacture

**Detector Positioning System**  
Finalising detailed design  
Preparing documentation

**Kinetics Slits**  
PDR complete  
Detailed design underway

**Collimation Translation Stages**  
PDR complete  
Detailed design underway

**NBOA (S-DH)**  
Alignment complete ✓

**Bunker Modules**  
TG3 approval pending  
Finalising drawings for manufacture



**Bunker Wall Insert**  
Manufacture underway  
COTS parts delivered ✓  
Alignment devices to be assembled by R12

**Chopper housings & WBC discs**  
Disc prototype tooling in manufacture  
Test housing in manufacture  
In-bunker upper housings out for manufacture

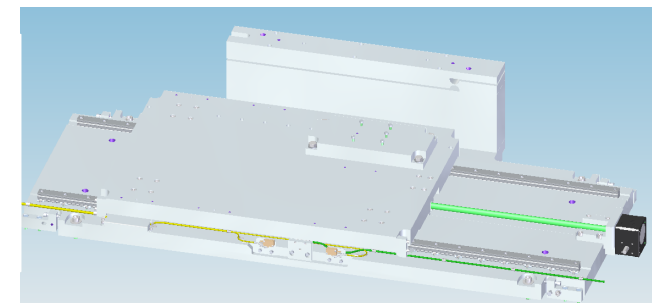

# NBOA/NBPI Integration

- The NBOA (in-monolith optics) have been in storage at ESS since December '21, awaiting delivery of the NBPI (port insert).
- The NBOA has now been integrated into the NBPI and aligned.
- Installation will be carried out by ESS Target group.

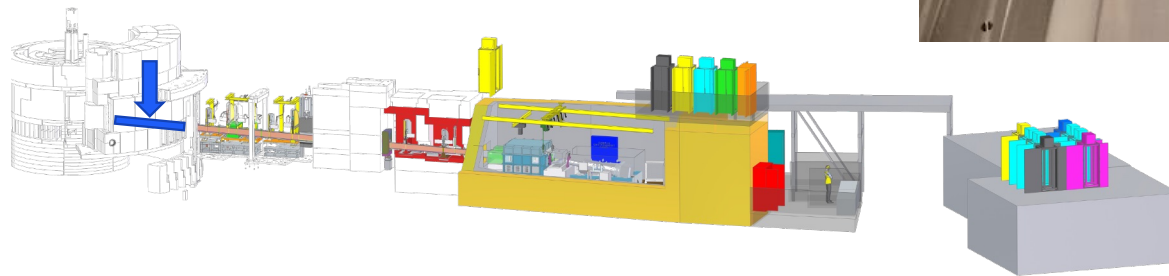
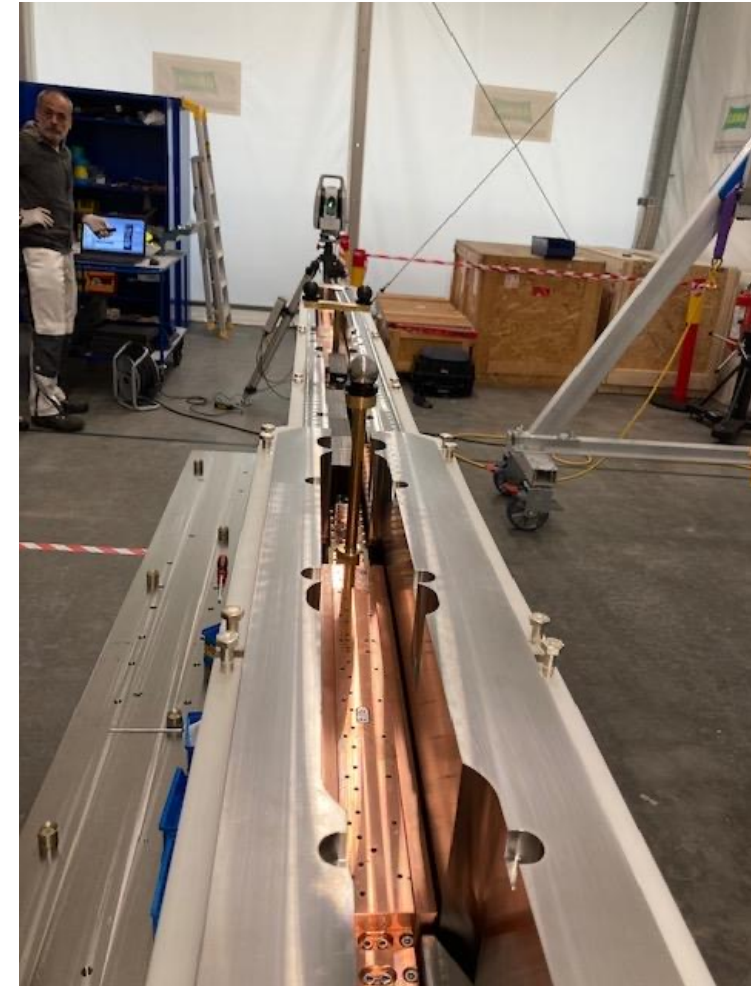

# Guide

- SNAG report that manufacture of the Bunker Feedthrough Vacuum Housing is underway, and due for completion in 23Q1, following which it will be shipped to ISIS for integration checks.
- Design focus has switched to the collimation guides, which have also been ordered from SNAG.
- Options for integration of a sample alignment laser are currently being evaluated.

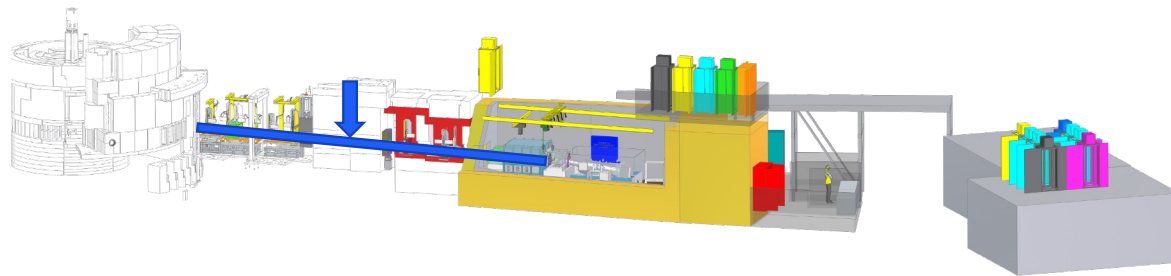

# Bunker Modules

- The changes from TG3.2 are implemented, and engineering drawings are being finalised.
- Planning for the manufacture is ongoing. A phased approach to manufacture will likely be needed, with parts grouped according to supplier capabilities.

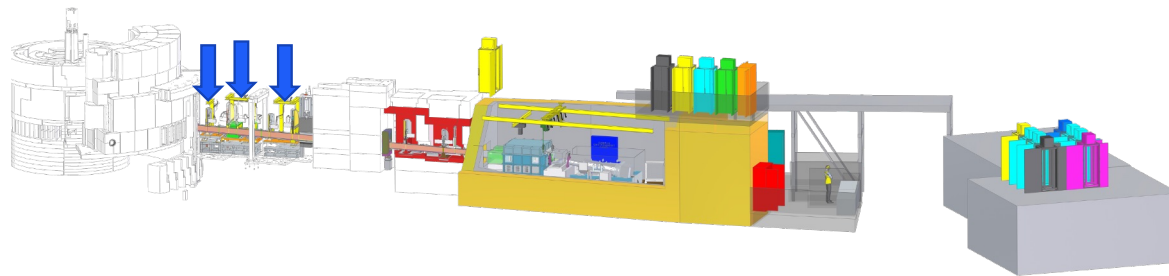
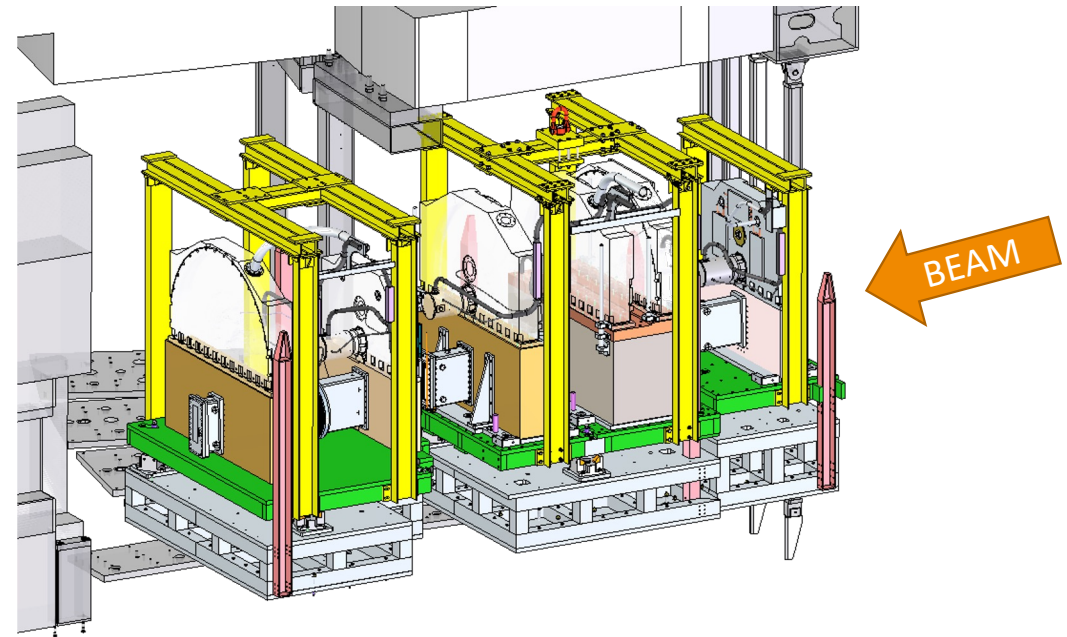

# Choppers

- In-bunker upper housings are in procurement, with some delays experienced due to UK govt procurement thresholds.
- A lower housing has been ordered which will be used for initial commissioning of the choppers, and future maintenance activities.

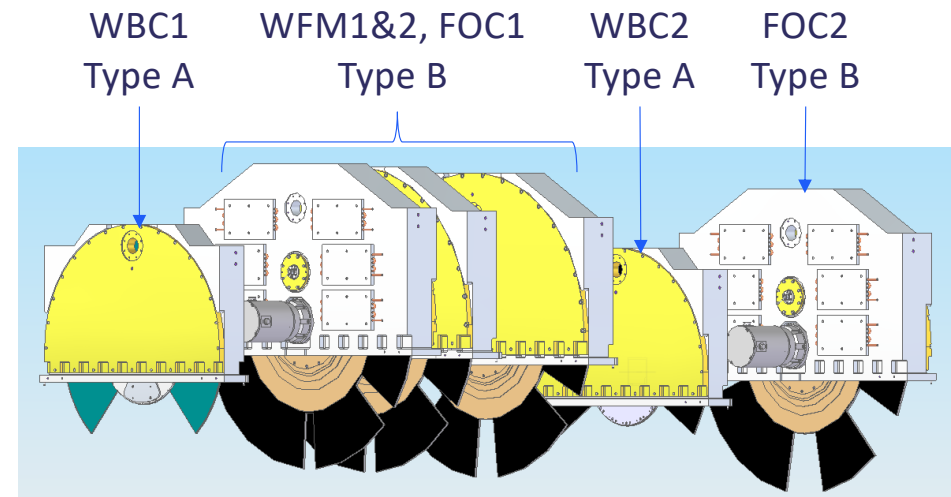

- SKF spindles & controllers are delivered to RAL.
- Cable procurement has been delayed due to global supply chain issues.

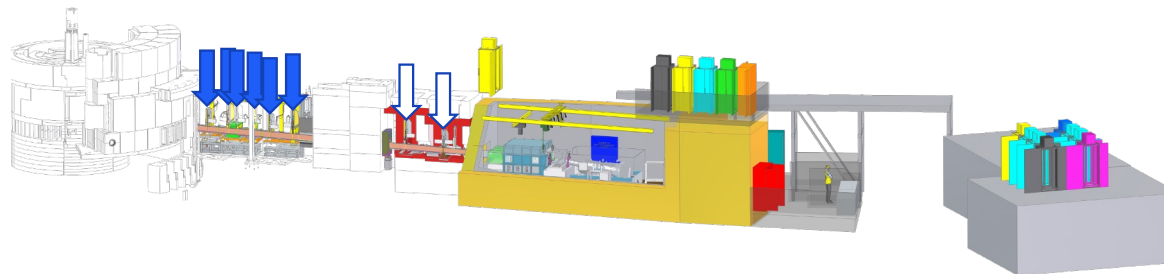

# Carbon-Fibre Chopper Discs

- The carbon-fibre chopper discs manufactured by ADSF have been delivered to RAL.
- The discs will stay in storage for ~6 months whilst the housings are manufactured.

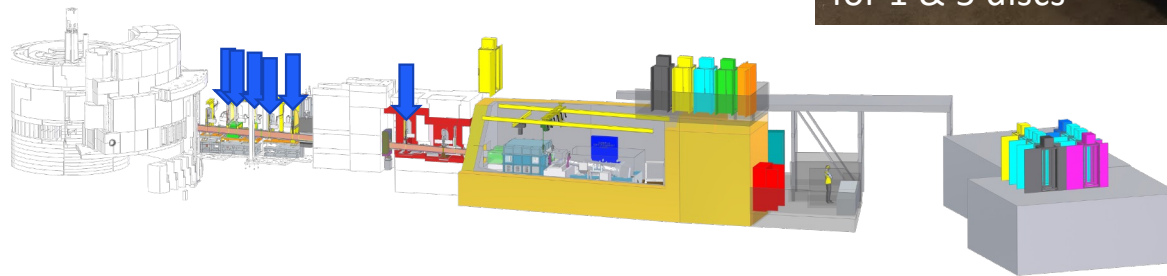
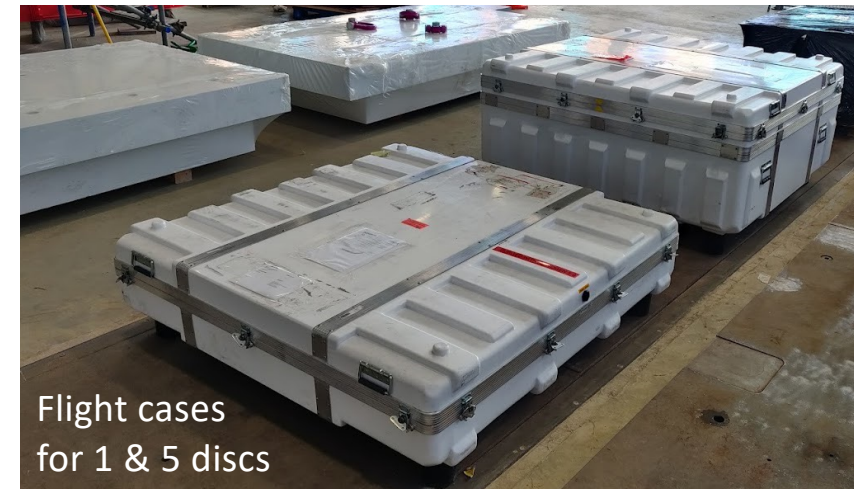
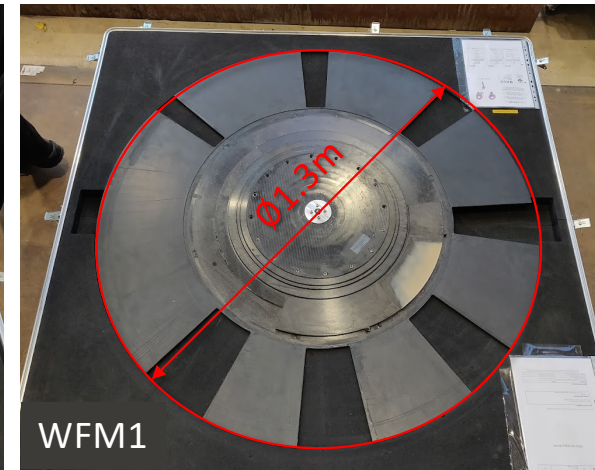
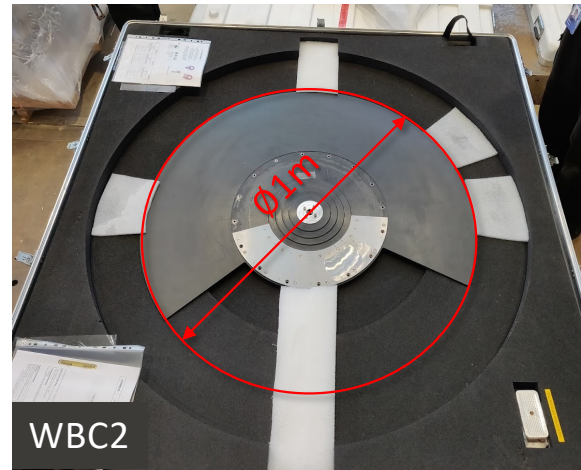

# Light Shutter

- The Light Shutter vacuum housing design has been approved, and manufacture is underway

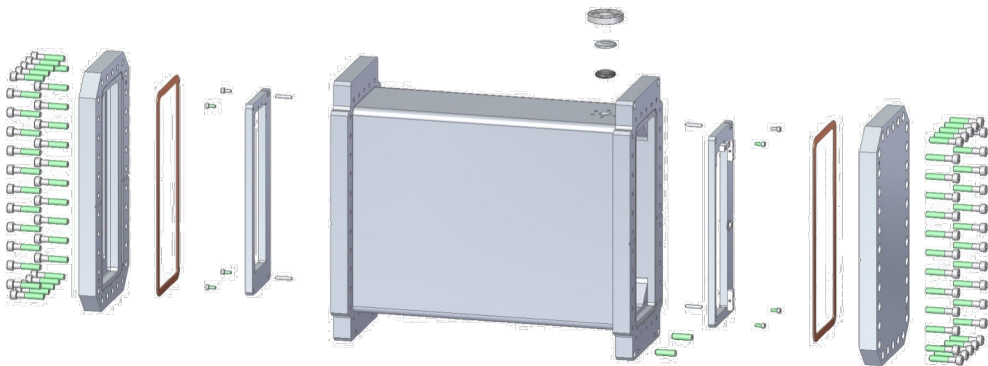

# Heavy Shutter

- The heavy shutter design has been refined, decoupling the shutter mechanism from the absorbing material.
- Neutronics simulations are ongoing to refine the composition of the beam dump.

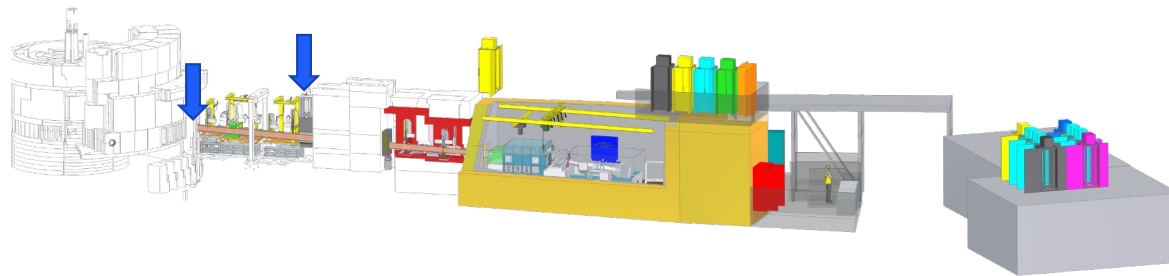
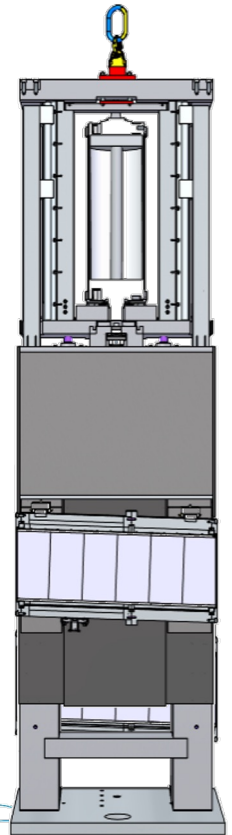

# Bunker Feedthrough

- The bunker feedthrough shielding insert design has been approved, and is ready for tender.
- The parts for the alignment devices are delivered, ready for assembly in November.

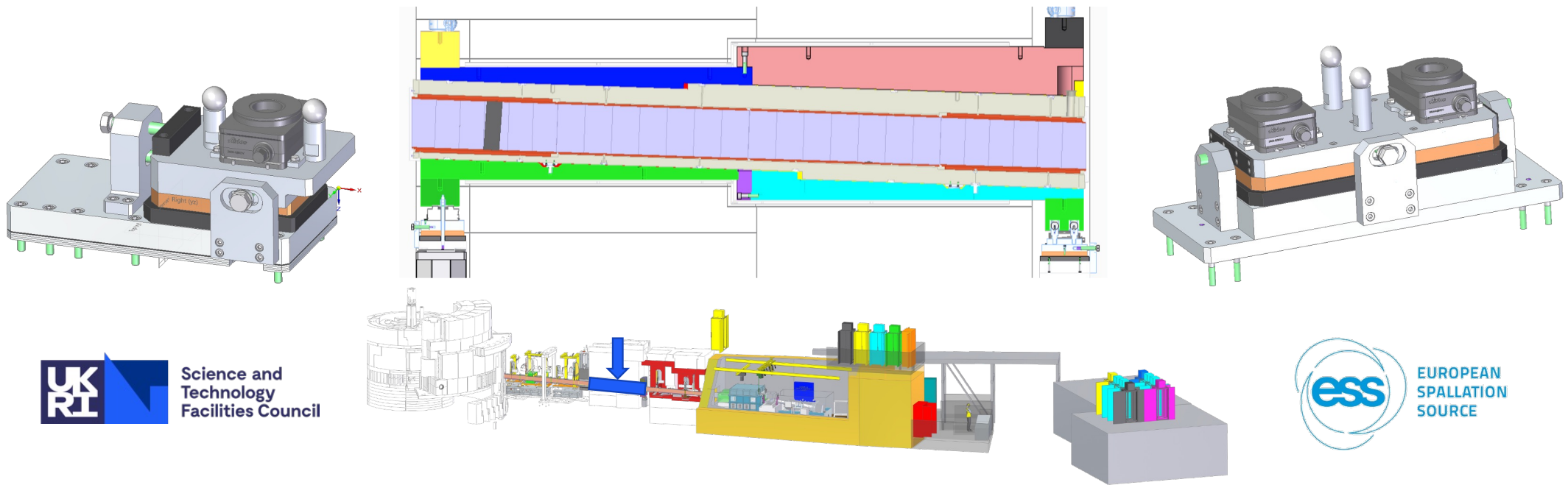

# Collimation System

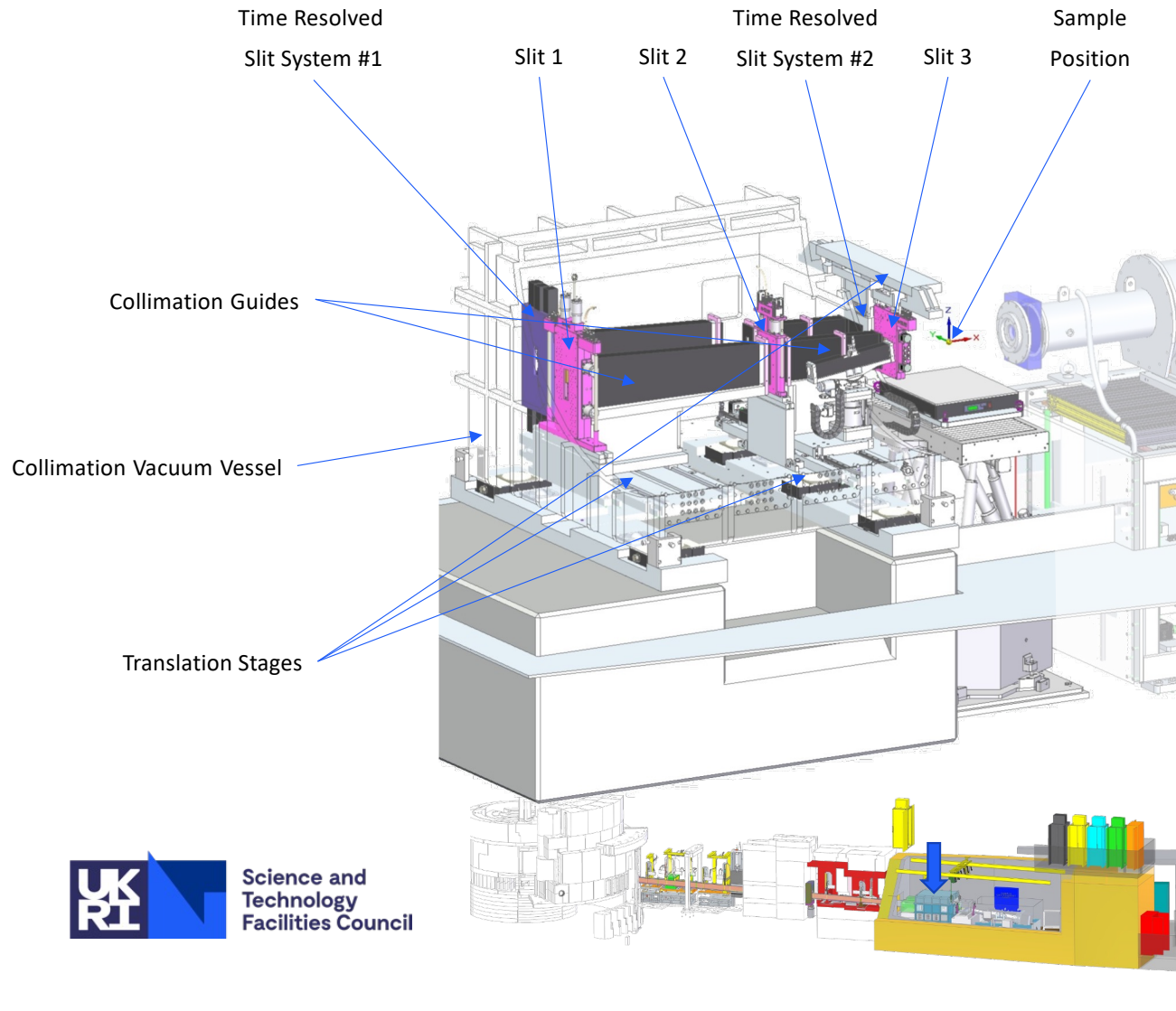

- Much of the collimation system is being designed at present, with some components approved for manufacture.
- The system will be pre-built at ISIS from 23Q2.

# Collimation Vessel

- The collimation vacuum vessel contract was awarded to AVS-ES who have good experience with vacuum vessels for ESS having delivered two for Loki.
- The design has been submitted to ESS & a 3rd party inspection authority (Lloyds) for approval.
- Manufacture is expected to start next month and should be complete in 23Q2.

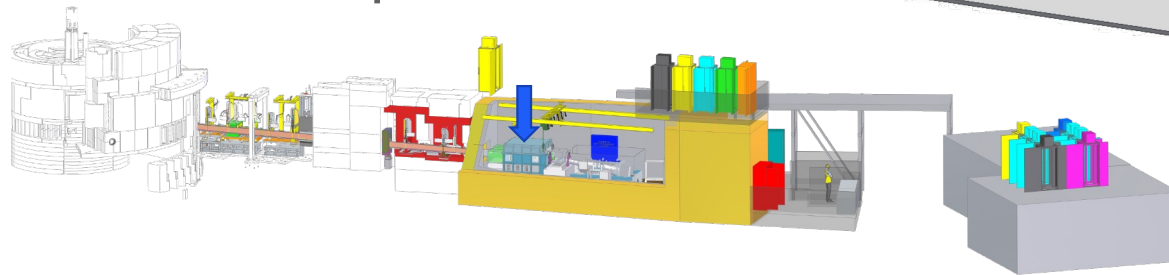
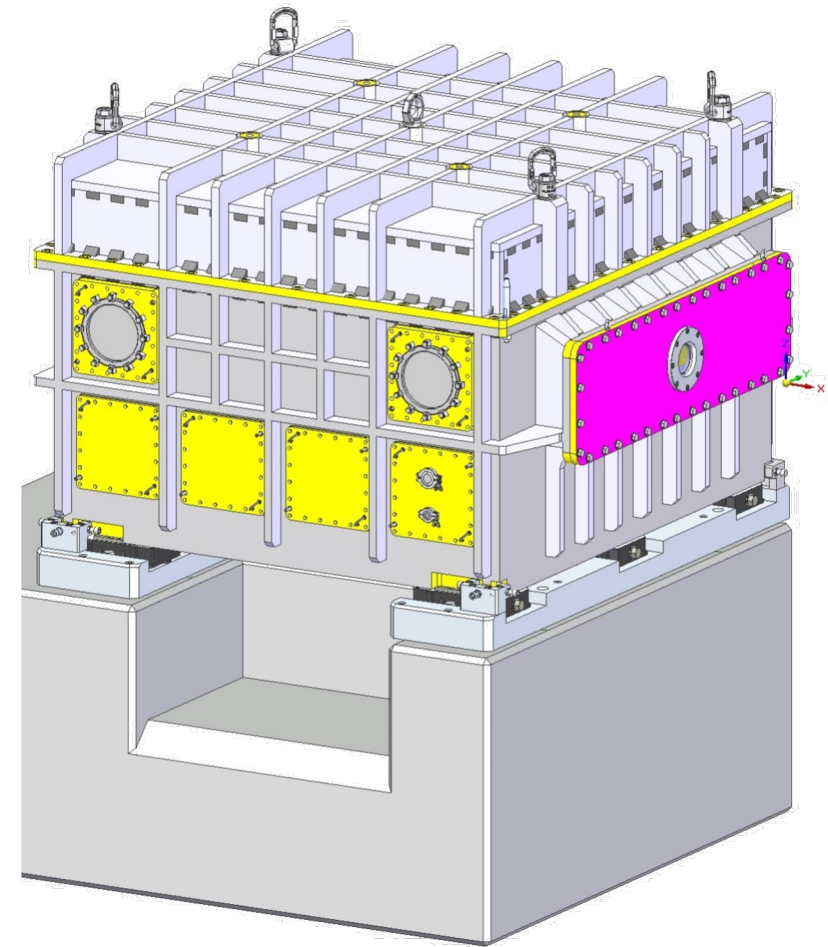

# Slits

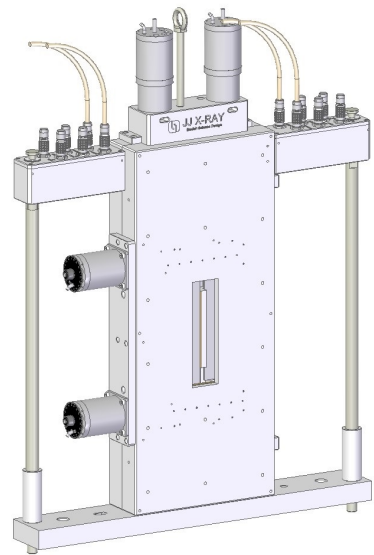

*Slit 1*

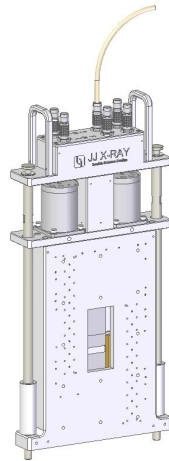

*Slit 2*

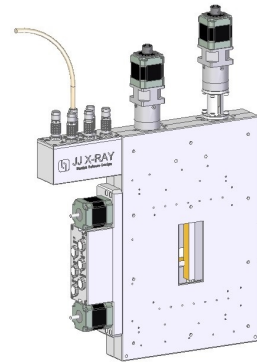

*Slit 3*

- JJ X-ray's design of the slits (S1-3) has been approved for manufacture by ESS as part of TG3.3.
- Manufacture is expected to be complete in 23Q2, with the lead times of LEMO connectors and Renishaw encoders dictating overall assembly timescale.

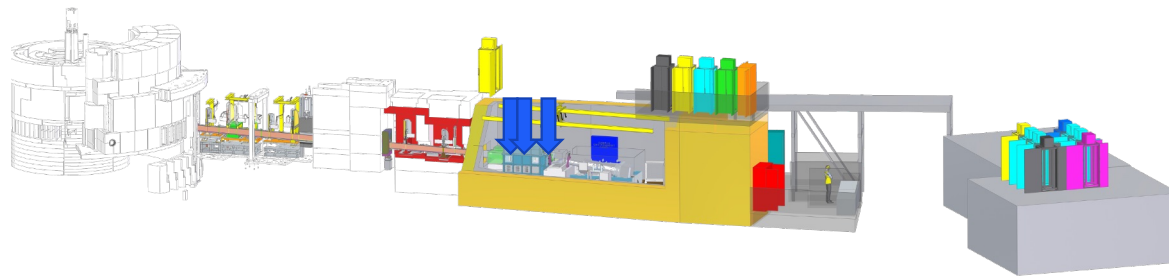

# Slits

- Sintered  $^{10}\text{B}_4\text{C}$  blades have been ordered from RHP.
- The blades use two different knife-edge geometries based on a recent design from ANSTO. Both geometries are to be tested during hot commissioning.

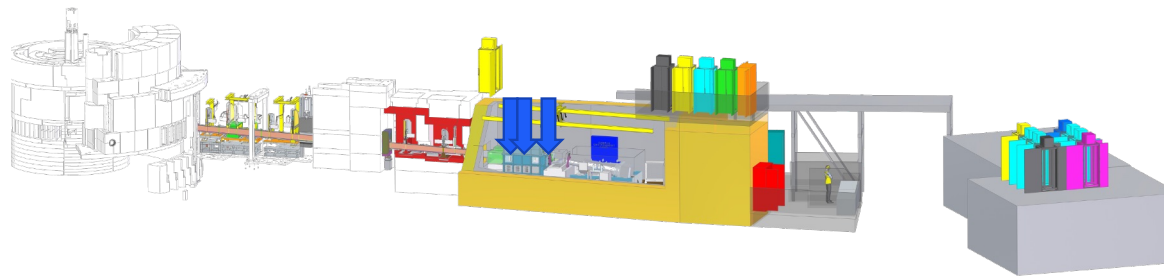
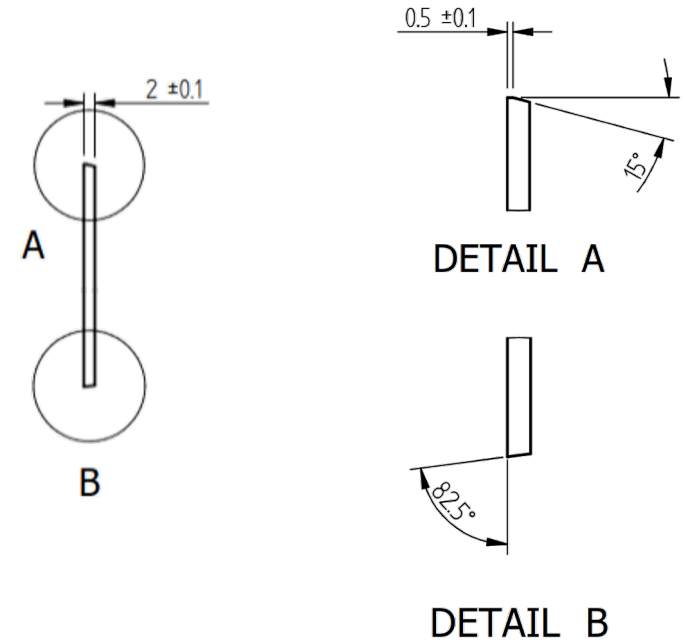

# Kinetics Mode

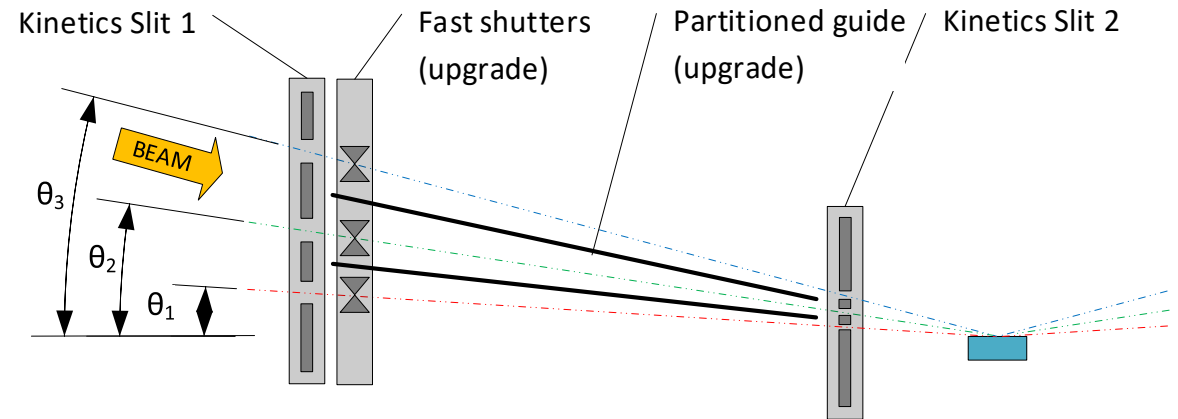

- Kinetics slit will allow for changing incident beam angle in 1-3 seconds, whereas fast shutters would be capable of changing angle on a pulse-by-pulse basis (14Hz).
- Partitioned guide and fast shutters are upgrade scope, which could be delivered for day-one, funding permitting.

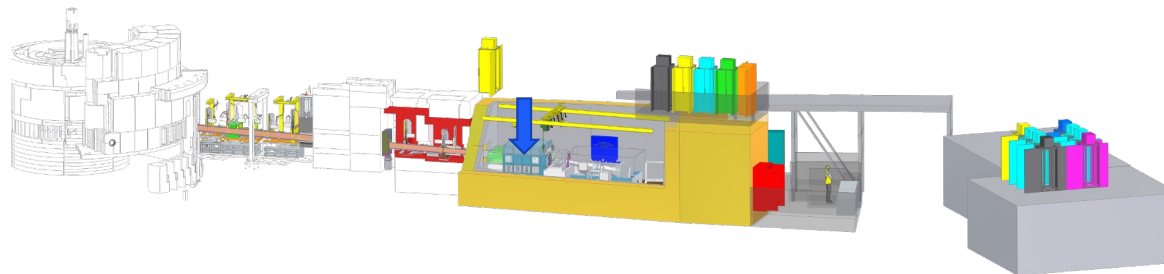

# Kinetics Mode: Slits

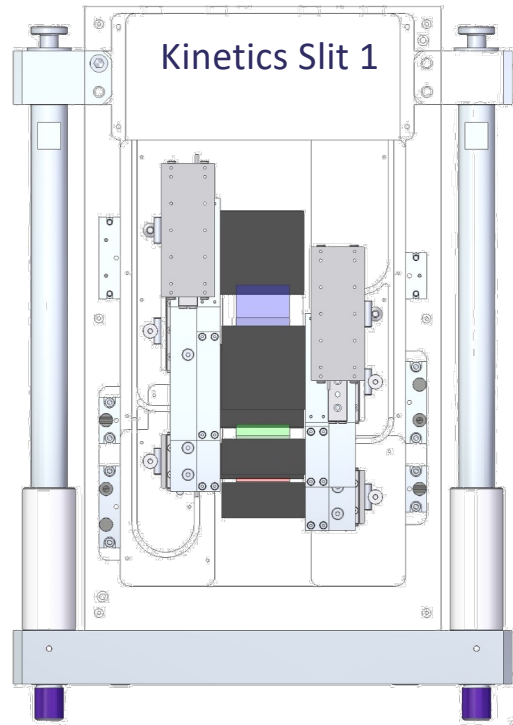

- Design of the 3-aperture piezo-driven slits is progressing, with an internal design review held in September.
- The two units share common design features to simplify the assembly process.

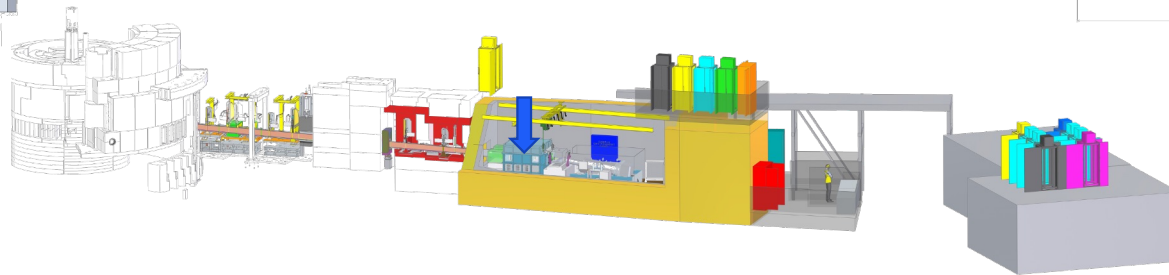
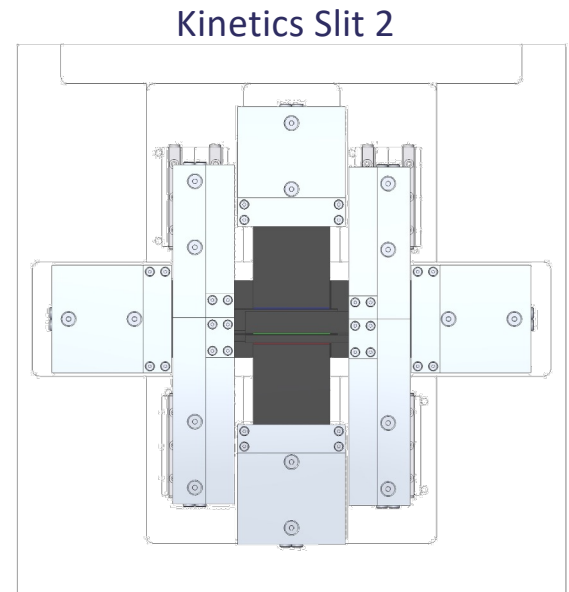
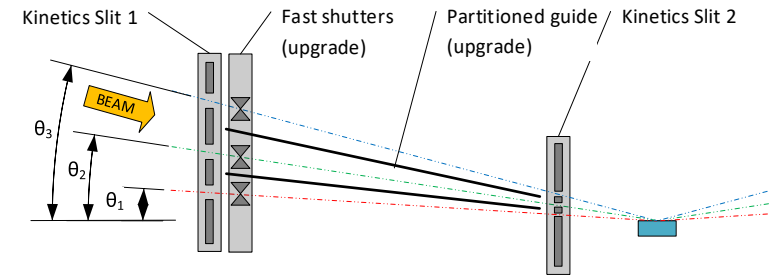

# Blade parallelism and straightness

- Both blade parallelism and edge straightness result in an error in the intended aperture size.
- This is only significant for small aperture sizes, but these are needed in some cases.
- For example:
  - A sample with a fixed footprint length of approx. 40mm, 3% angular resolution
  - Nominal first angle =  $0.45^\circ$ ,  $Q_{\min} \approx 0.01 \text{ \AA}^{-1}$  (Si-D<sub>2</sub>O critical edge  $0.0145 \text{ \AA}^{-1}$ )
  - S1 aperture  $\approx 750 \text{ \mu m}$  and S2 aperture  $\approx 140 \text{ \mu m}$
  - An error of circa  $20 \text{ \mu m}$  at S2 has a significant impact on illuminated footprint  $\pm 3 \text{ mm}$
  - An error of circa  $120 \text{ \mu m}$  at S1 has the same impact on illuminated footprint  $\pm 3 \text{ mm}$
  - An error of  $35 \text{ \mu m}$  for both slits will give an overall circa 6% error in the footprint at  $0.45^\circ$

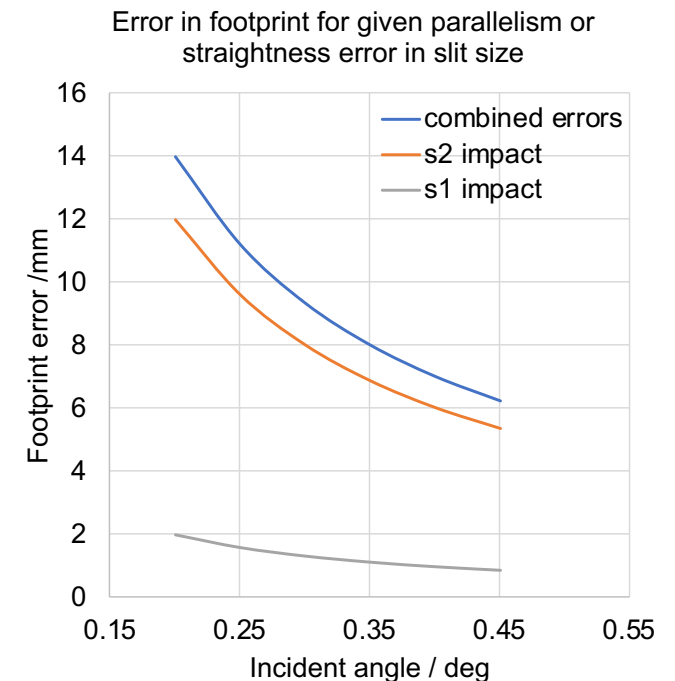

# Kinetics Mode: Slits

- Calculations suggest that blade edge uncertainty (flatness, parallelism) of  $<35\mu\text{m}$  is necessary to limit footprint error at very low incident angles.
- Investigations to quantify the achievable flatness for the knife-edges are ongoing.
- Measurements of blades purchased for SURF show that flatness of  $\sim 20\mu\text{m}$  can be achieved.

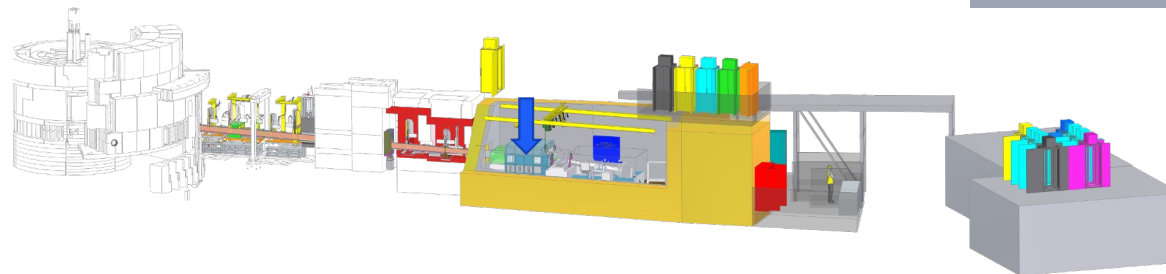
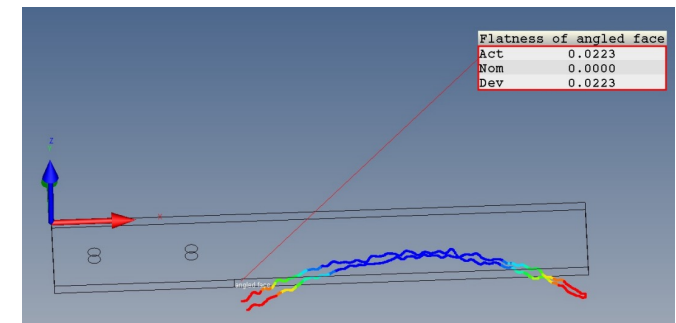
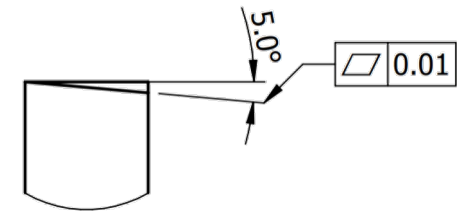
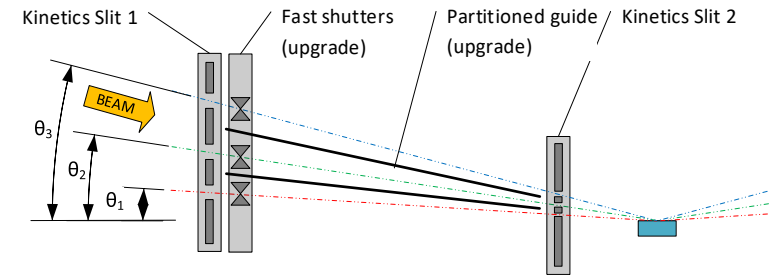

# Kinetics Mode: Slits

- The sequence of the blades was chosen so that the apertures appear smaller to higher angles and should therefore be easier to correct.

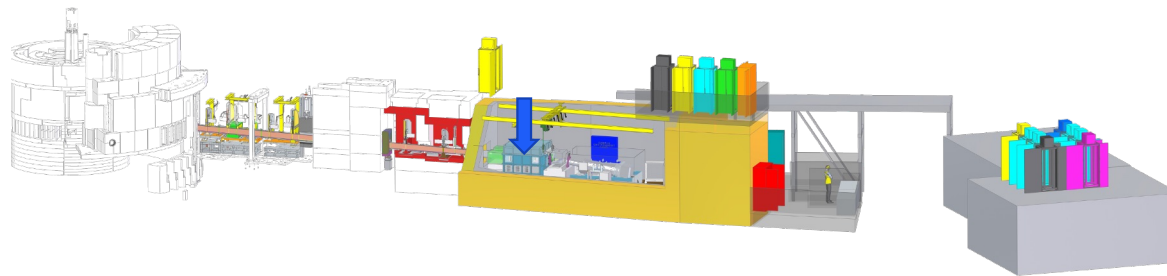
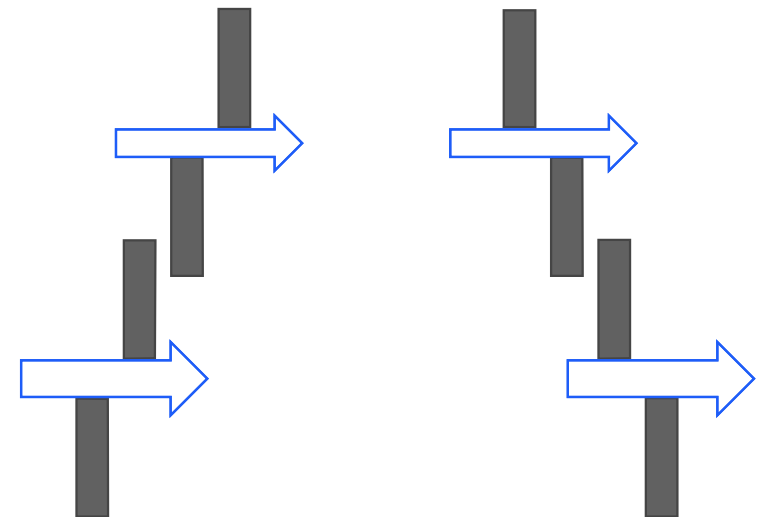
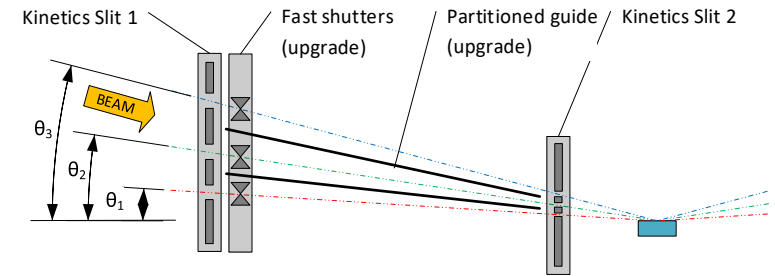

# Kinetics Mode: Slits

- The blades must be stacked to allow for free movement of the piezo stages (i.e. to avoid collisions).
- The sequence of the blades has been chosen so that the apertures appear smaller to higher angles so that they close sooner than expected.

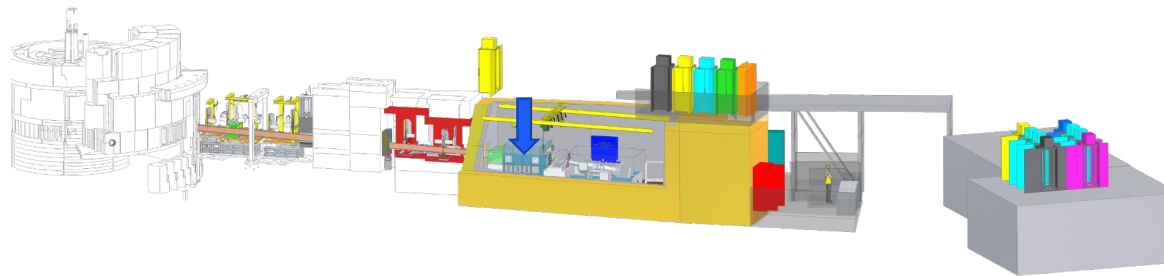
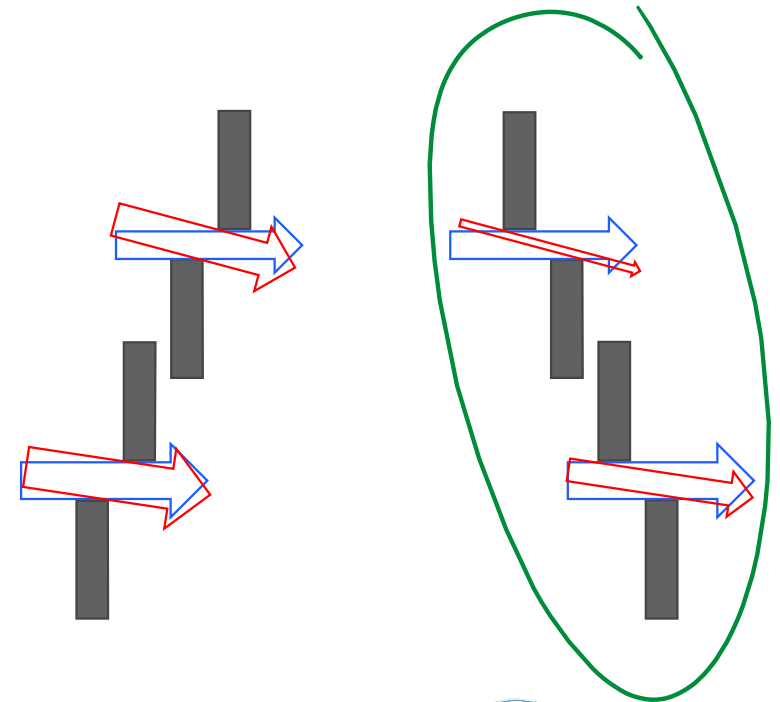
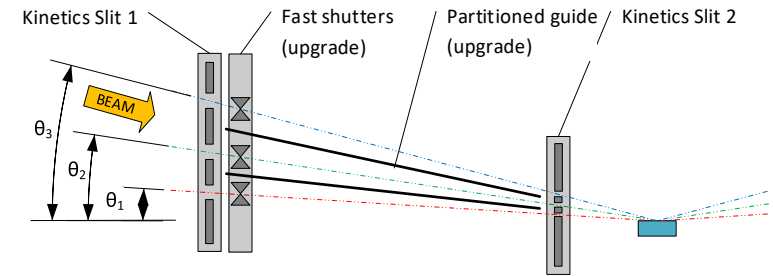

# Kinetics Mode: Slits

- As with the standard slits, the leading edges are knife-edged. The orientation was chosen to minimise parallax error.
- There is also flexibility to change the orientation of the blades to optimise parallax during hot commissioning .

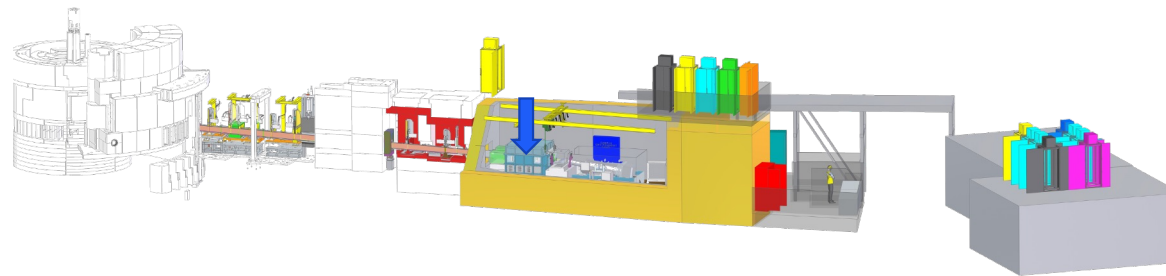
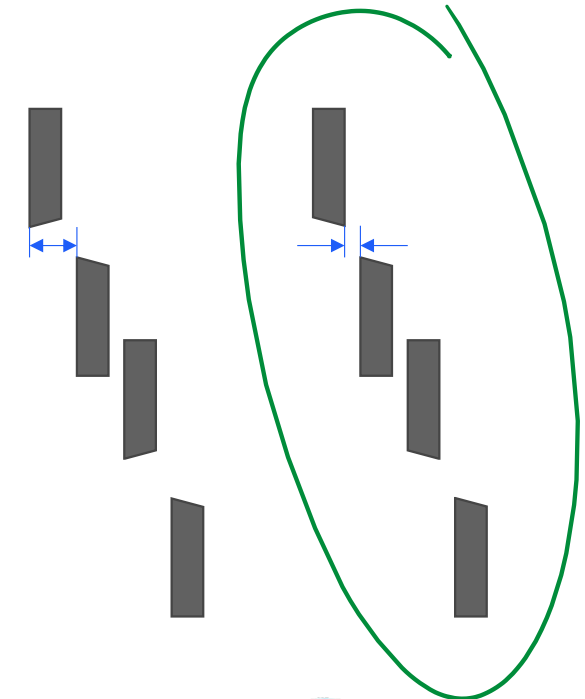
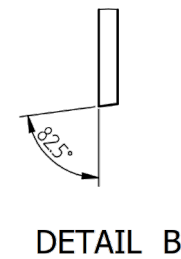
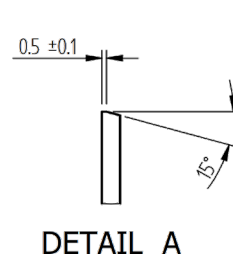
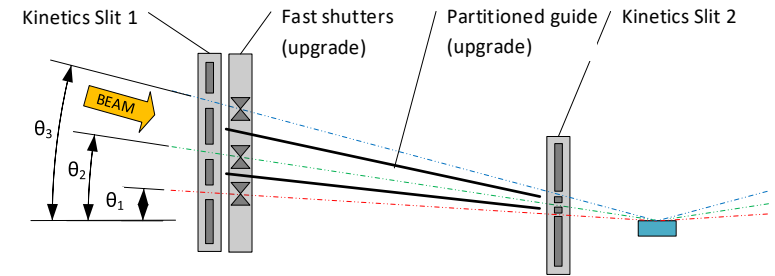

# Kinetics Mode: Fast Shutters

- A prototype developed by Uppsala University was tested with neutrons at ISIS in July.
- The ability to cut the beam at specified time was demonstrated.
- A final design of the shutter system is to be developed as part of the UU collaboration, with investigations into vibration isolation and cooling ongoing.

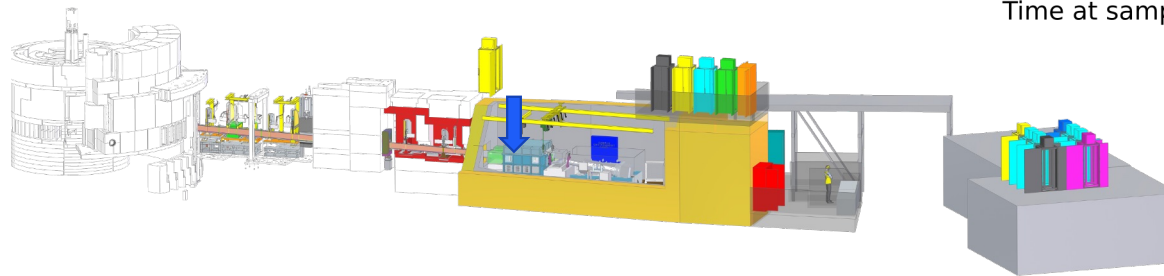
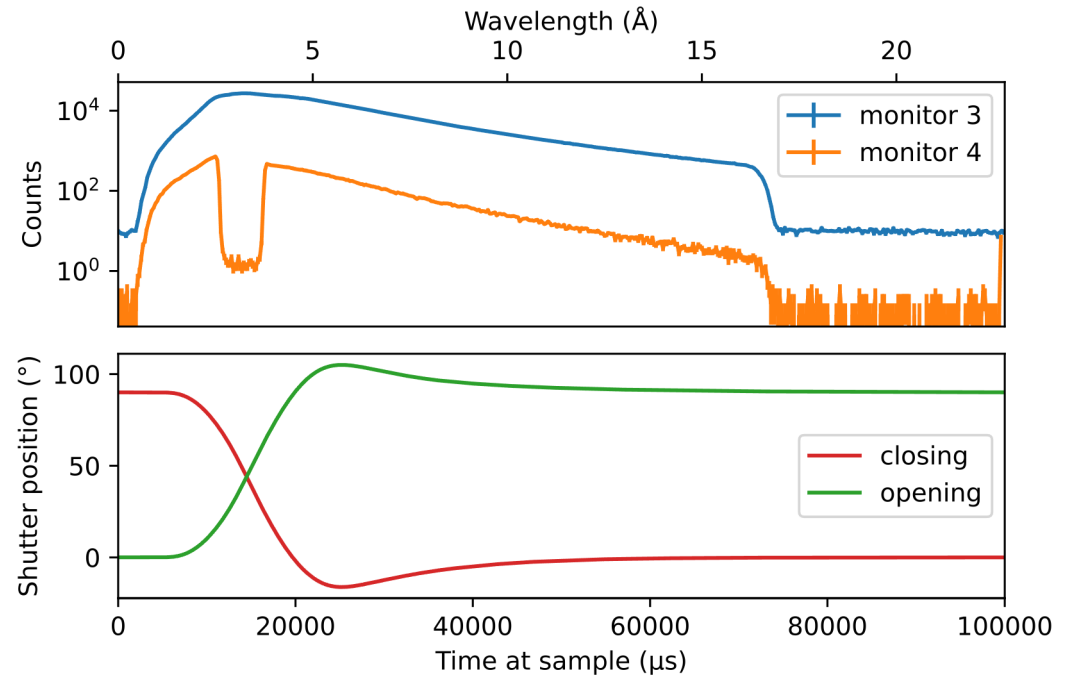
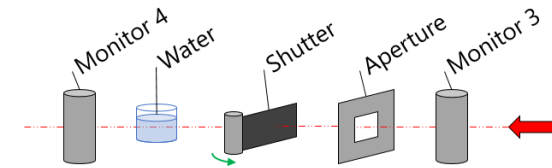

# Sample Positioning System

- The Sample Positioning System comprises a hexapod with an integrated Y-translation stage for sample changing manufactured by Symétrie.
- The design was approved for manufacture as part of TG3.3, will be delivered to ESS in 23Q2-3.

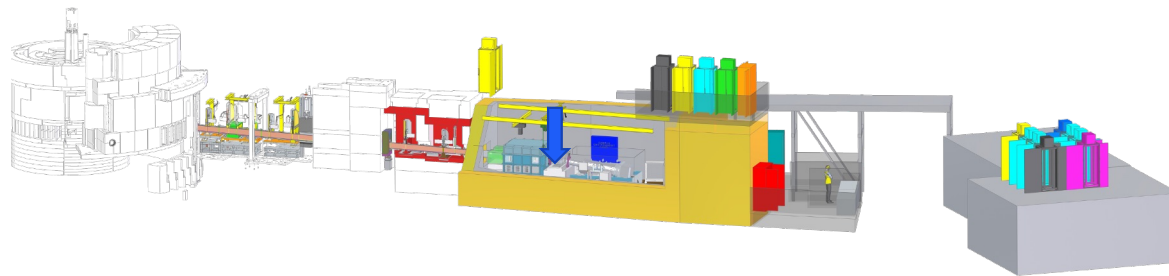
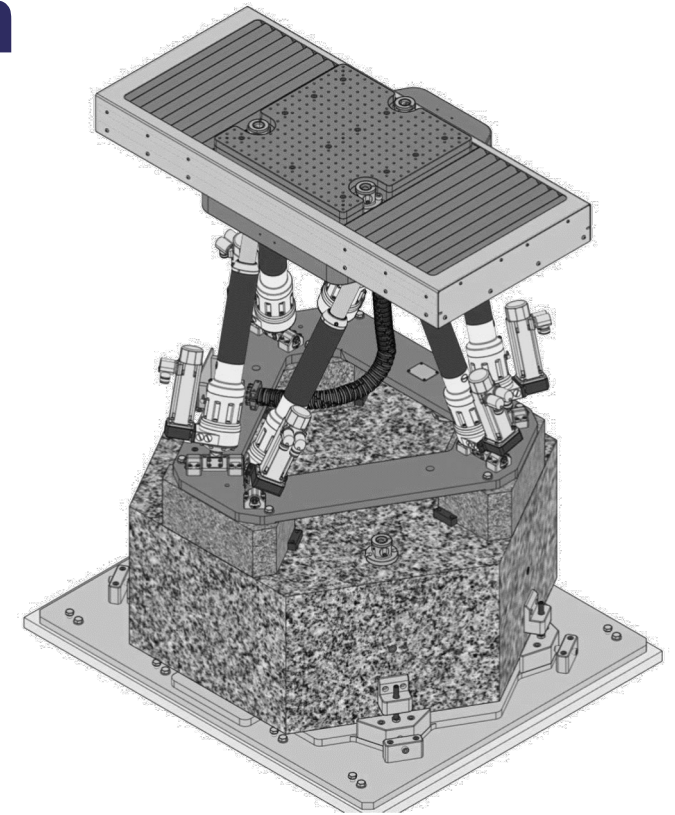

# Sample Environment

- Solid-liquid cell projects are progressing with detailed integration design for ESTIA & FREIA

Solid-Liquid Cells & sample changer (UU)

In-situ Ellipsometry / IR  
& sample changer (LiU)

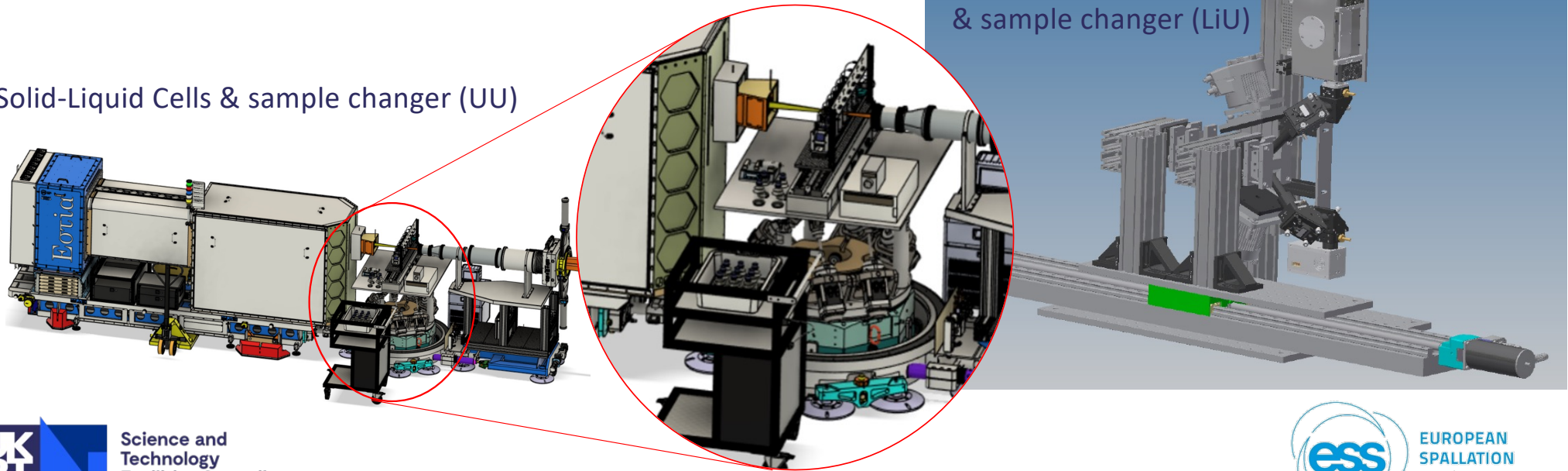

# Question from last STAP meeting: Inversion geometry

- How does gravity effect the inversion mirror geometry?

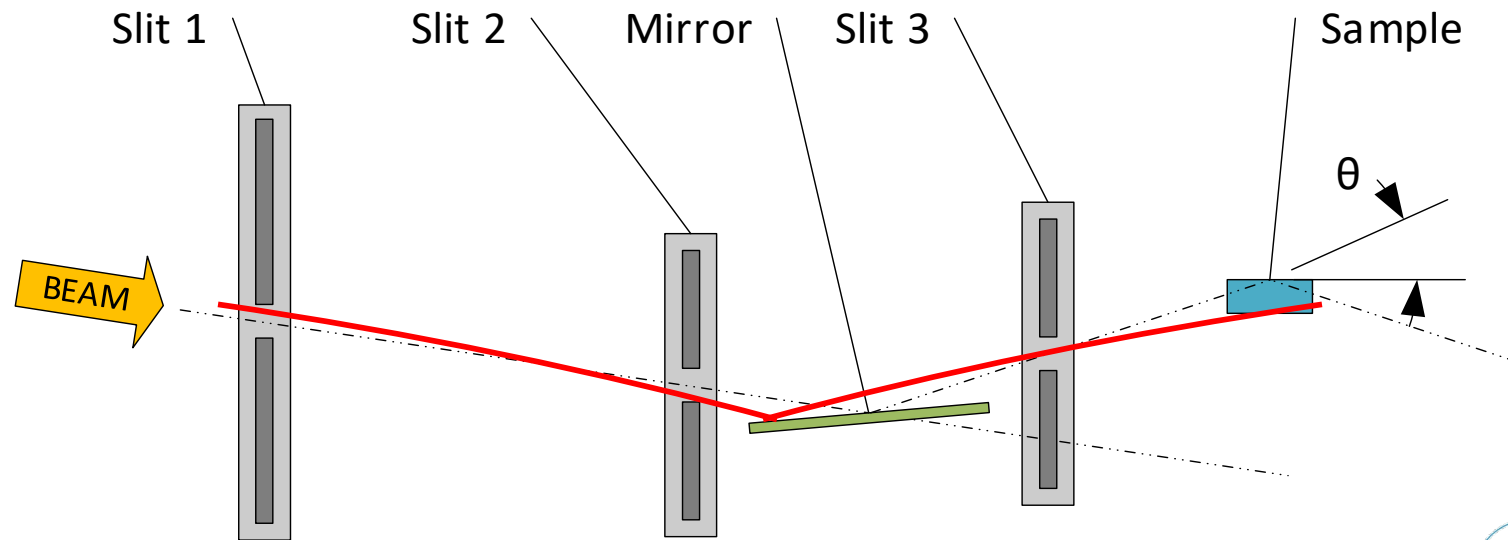

# Parabolic trajectories: with the sample in the normal orientation

- Angle of incidence is higher than expected for longer wavelengths and the position on sample surface is earlier

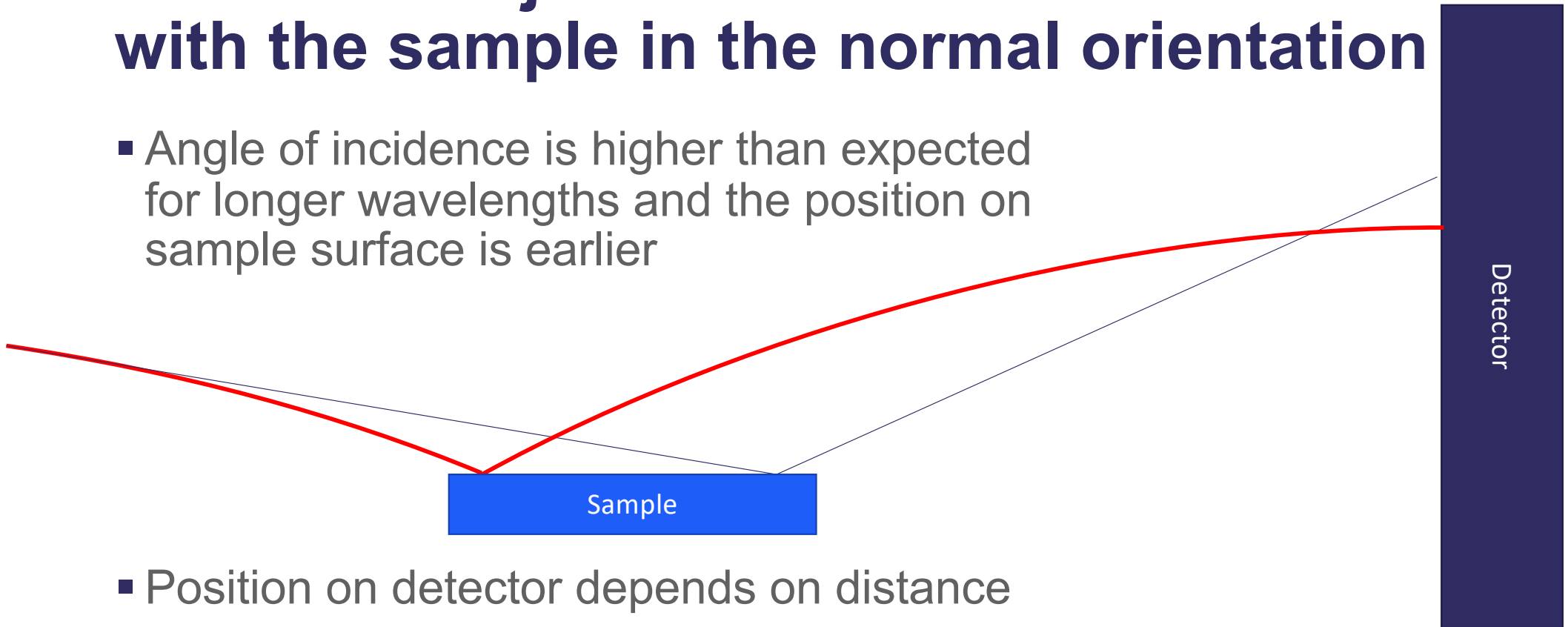

- Position on detector depends on distance

# Parabolic trajectories: with the sample in the normal orientation

- Instrument proposal showed that this is only really relevant for pulse-skipping modes

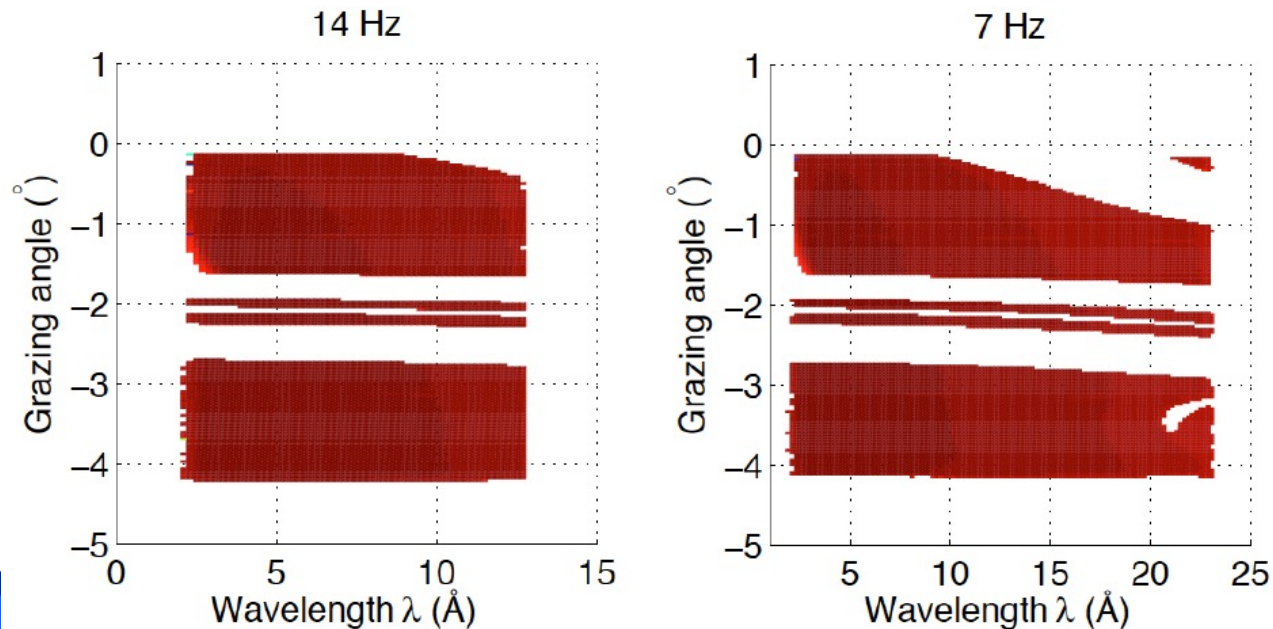
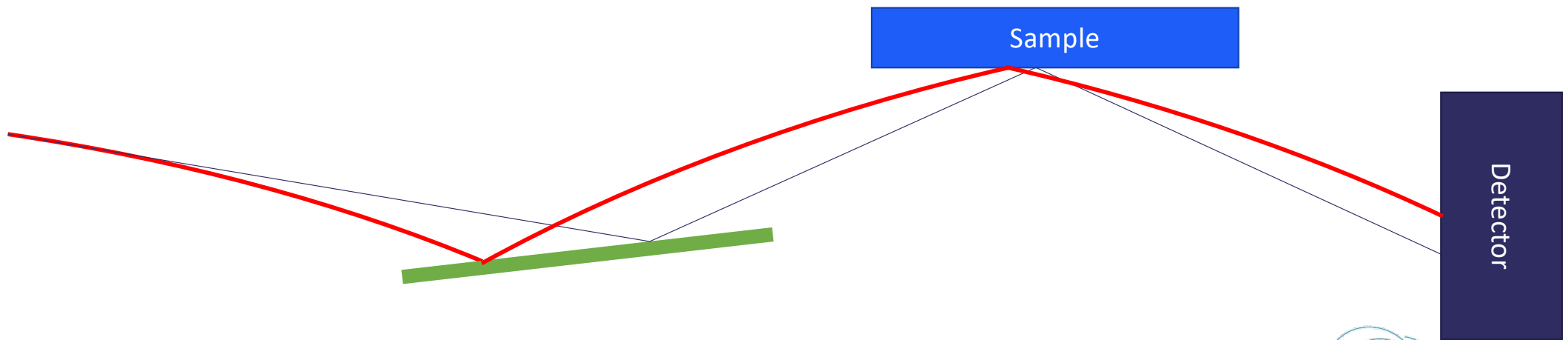

Figure 9 in instrument proposal shows that some angles of incidence are not accessible for the longer wavelengths particularly when pulse skipping

# Parabolic trajectories: with the inversion mirror

- Angle of incidence and position on sample surface may be higher or lower than expected depending on distances & wavelength



# Parabolic trajectories: with the inversion mirror

- Note that this is essentially the same as the normal case for horizontal reflectometers, but in reverse!

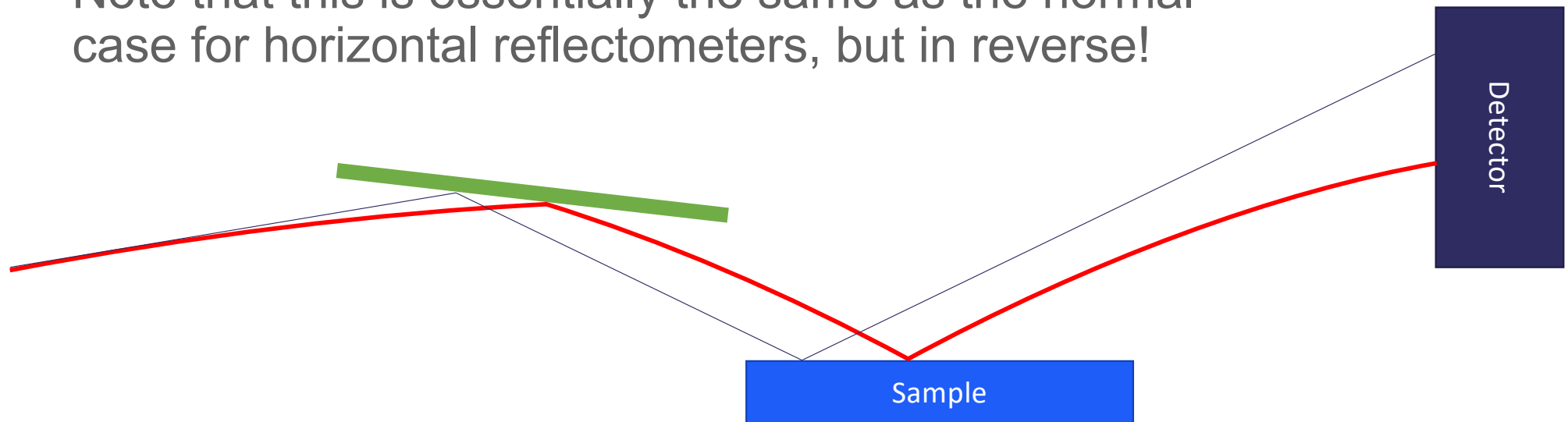

- So the corrections are the same but with a change of sign

# Parabolic trajectories: with the inversion mirror

- McStas simulation showing the effect with inversion mirror:
  - With slits in place collimation to beam footprint of 8cm & nominally 6% resolution

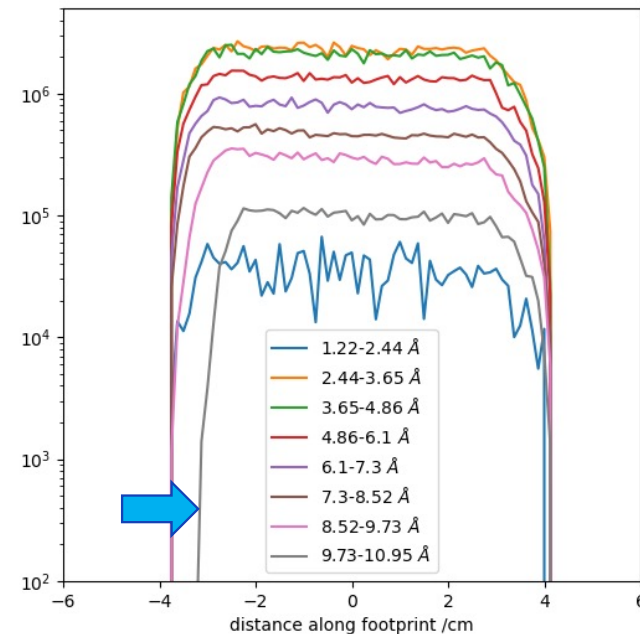
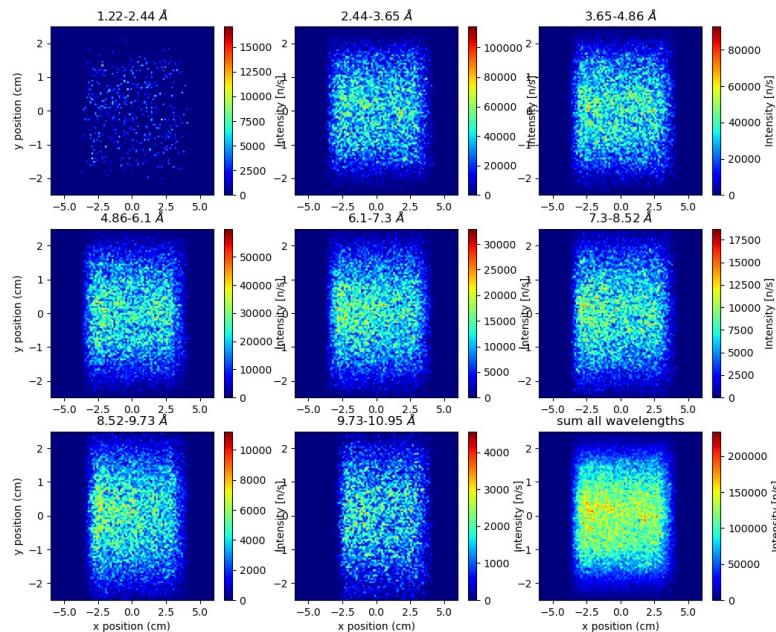

- Only longest wavelengths  $>10\text{\AA}$  have marginally smaller footprint



# Challenges

- Supply chain delays
  - Long lead components ordered with significant float.
  - Investigating options for alternative chopper cable supply.
- Motion control cable delays
  - Unclear specifications from ESS on long lead items are impacting our ability to deliver cables to suppliers for testing.
  - Order placed based on old specification, and re-order if there are changes.
- Neutronics resource
  - Limited neutronics resource at ISIS is holding up design of the heavy shutter and shielding.

# Challenges

- Engineering resource (resolved?)
  - Lost several key members of the instrument team in Q1
  - New engineer (Lily Galvin) started in August + increased reliance on contractors
  - Graduate engineer (Helen Popland) starting in Oct + rotations (Callum McDonnell/Harry Sullivan)

## UK-ESS Instrument Project Team

LoKI	Freia
<b>LoKI Lead Engineer</b> Jim Nightingale	<b>Freia Lead Engineer</b> Jon Elmer
<b>Design Engineer</b> David Turner	<b>Design Engineer</b> Miguel Campos
<b>Design Engineer</b> Anton Orszulik	<b>Graduate Engineer</b> Callum McDonnell (Apr-Sep)
<b>Design Engineer</b> Chris Cornall	<b>Design Contractor</b> Phil Harrison (Aug-)
	<b>Design Engineer</b> Lily Galvin (Aug-)
	<b>Graduate Engineer</b> Harry Sullivan (Oct-Feb)
	<b>Design Engineer</b> Helen Popland (Oct-)



Science and  
Technology  
Facilities Council



EUROPEAN  
SPALLATION  
SOURCE

**Thank you**  
**Questions?**