

DREAM update for STAP

M. Feyngenson^{1,2}, W. Schweika^{1,2}, P. Harbott¹, A. Poqué¹, A. Schwaab¹,
F. Porcher³, S. Desert³, G. Fabreges³

¹ Forschungszentrum Jülich, Germany

² European Spallation Source ERIC, Sweden

³ Laboratoire Leon Brillouin, France



DREAM instrument

- **Partners: FZJ 76% (Lead Partner), LLB 20%, ESS 4%**

Construction budget: 13.66 M€

Completion: Q4 2023

Exptl. Cave (LLB)

- Installed

Infrastructure (ESS)

- CUP, CEP, PSS

Cryofurnace (LLB)

- ESS scope

Detectors (FZJ)

- In Mfg. (CDT)
- Installed: Q1 23 – Q4 23

Disc choppers (FZJ)

(PSC, OC & BC)

In Mfg. (FZJ & racks ESS)

T0 (ESS)

Mfged

Installed: > Q1 2023

Sample vessel (FZJ)

- Installed

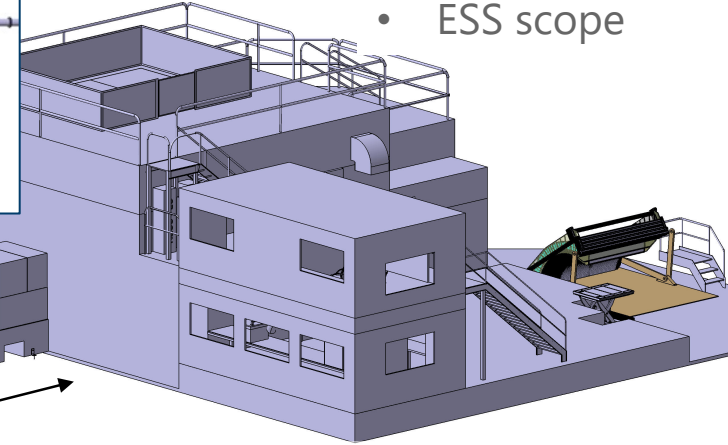
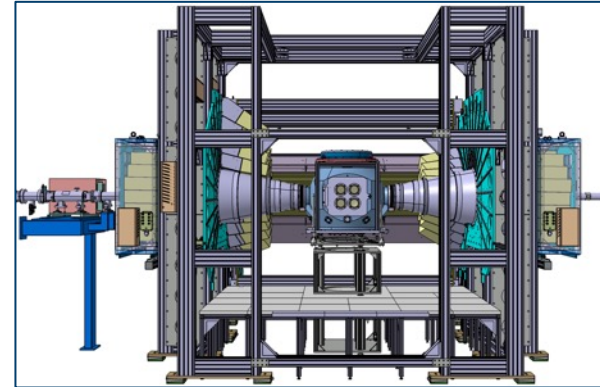

NBOA (FZJ)

- SNAG
- Mfged
- Installed: Q1 23

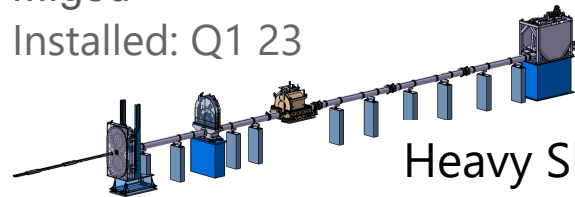

Heavy Shutter (ESS)

Inside the bunker

Neutron Guides (FZJ)

- SNAG
- Mfged
- Installed: Q1 23
- Guide shielding (ESS)

Control hutch and sample prep lab (FZJ)

- Installed

In-bunker installation: Jan '23 - July '23

Early access: Nov '22 (heavy shutter, T0 chopper)

Installation overview

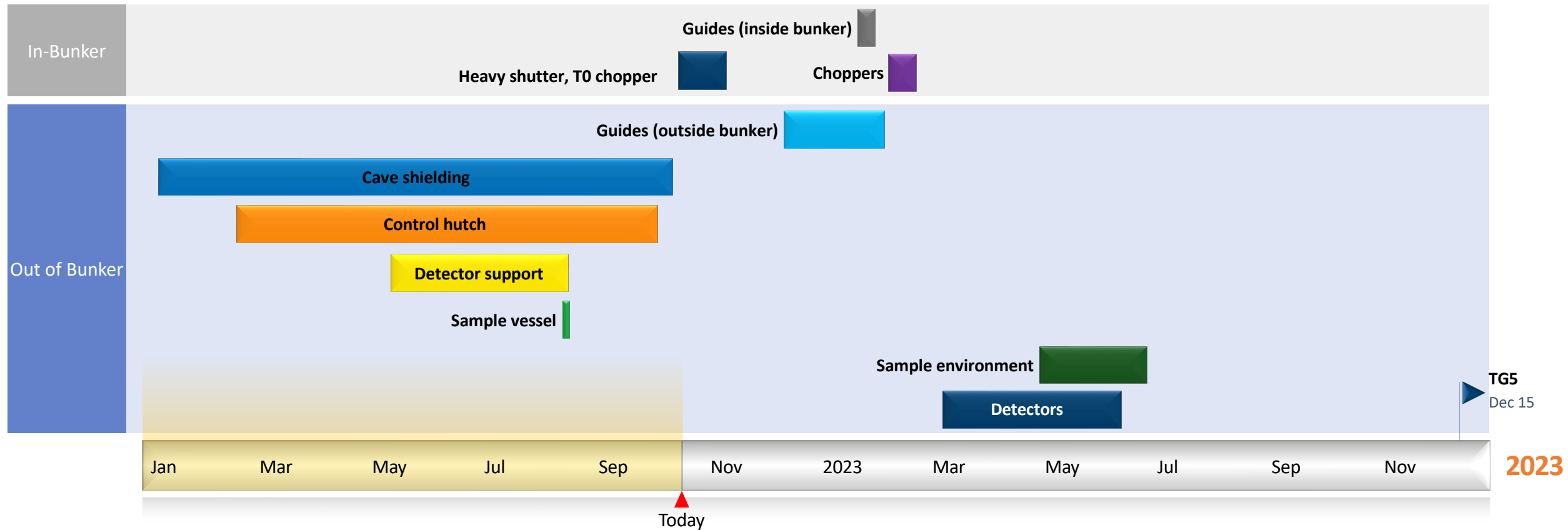

- Final design review (TG3) meeting took place in August 2022
- In-bunker access delayed to Jan. 2023
- TG5 is scheduled for December 2023
- DREAM will be ready for first neutrons in 2025

Project reporting

- ESS planners have direct access to FZJ-LLB SmartSheets
- Extracted milestones are sent to DREAM team for verification
- Results are presented to NSS during in-person monthly meetings

P6 view (ESS)

The screenshot shows the Jülich SmartSheet interface. On the left, there's a 'Browse' sidebar with 'Workspaces' expanded to show '10_DREAM'. The main area displays a table of workspace entries:

Name	Sharing	Owner	Last Update
01_Project Plan TA	Workspace	JCNS PMO (t.claudio.weber@fz-juelich.de)	06/03/22
02_DREAM_Engineering	Workspace	JCNS PMO (t.claudio.weber@fz-juelich.de)	06/01/22
03_Project Plan LLB	Workspace	JCNS PMO (t.claudio.weber@fz-juelich.de)	06/01/22
05_Project Dashboard	Workspace	JCNS PMO (t.claudio.weber@fz-juelich.de)	02/03/22
10_Project Milestones	Workspace	JCNS PMO (t.claudio.weber@fz-juelich.de)	03/27/22
12_Upcoming Tasks	Workspace	JCNS PMO (t.claudio.weber@fz-juelich.de)	03/24/22
14_Completed Tasks	Workspace	JCNS PMO (t.claudio.weber@fz-juelich.de)	02/03/22
15_Overdue Tasks	Workspace	JCNS PMO (t.claudio.weber@fz-juelich.de)	02/03/22
20_Installation	Workspace	JCNS PMO (t.claudio.weber@fz-juelich.de)	02/03/22
22_Installation Antonio	Workspace	JCNS PMO (t.claudio.weber@fz-juelich.de)	02/03/22
50_Logistics_Direct	Workspace	JCNS PMO (t.claudio.weber@fz-juelich.de)	02/03/22
51_Logistics_FZJ	Workspace	JCNS PMO (t.claudio.weber@fz-juelich.de)	02/03/22
55_Procurement	Workspace	JCNS PMO (t.claudio.weber@fz-juelich.de)	02/03/22
70_Financial	Workspace	JCNS PMO (t.claudio.weber@fz-juelich.de)	05/20/22
71_Financial Paid and Invoiced Mil...	Workspace	Ulrike Nägele (u.naegle@fz-juelich.de)	05/24/22
71a_Financial Wo			
72_Financial 202			
73_Financial 202			
74_Financial 202			
75_Financial 202			
76_Financial 202			

The screenshot shows the 'DREAM Project DASHBOARD'. It includes a 'Project Information' section with a progress bar at 66% complete, a 'Tasks by Status' donut chart, and several task lists:

- 12 Upcoming Tasks:** A table listing tasks like 'Detectors support', 'Tollgate 3', and 'Hutch building + control' with their status and end dates.
- 14 Completed Tasks:** A table listing completed tasks like 'Detectors support' and 'Sample vessel'.
- 15 Overdue Tasks:** A section for tasks that are past their due date.

The screenshot shows a Gantt chart for the '13.5 Instrument Technology' and '13.6 Instrument Construction' phases. The chart displays activities with their start and finish dates. A blue arrow points from the workspace list in the previous screenshot to this Gantt chart. On the right, a 'P6 view (ESS)' shows a detailed project network diagram with milestones and task dependencies.

Neutron Beam Optics Assembly / Bridge Beam Guide / Bi-spectral Switch

NBOA

Neutron Beam Extraction (NBEX)
Resp: Target Division

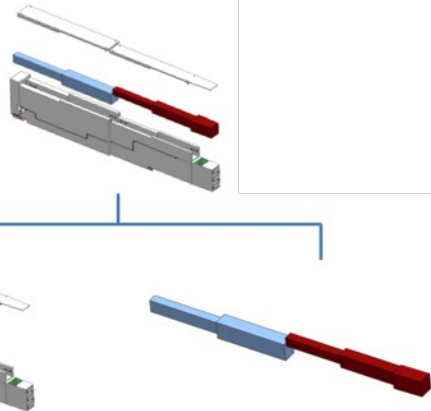

Neutron Beam Port Insert (NBPI)

Neutron Beam optical assembly (NBOA)

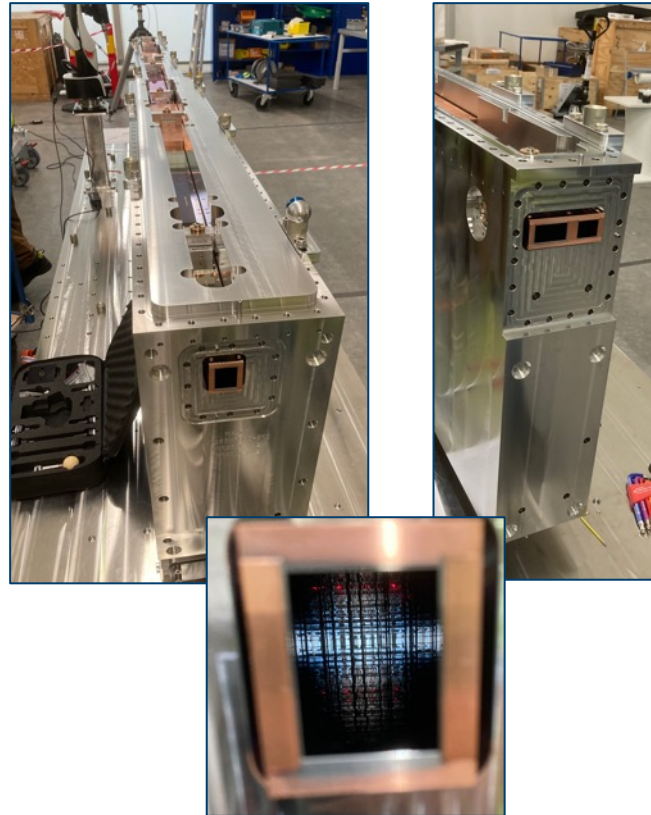

Bi-spectral switch

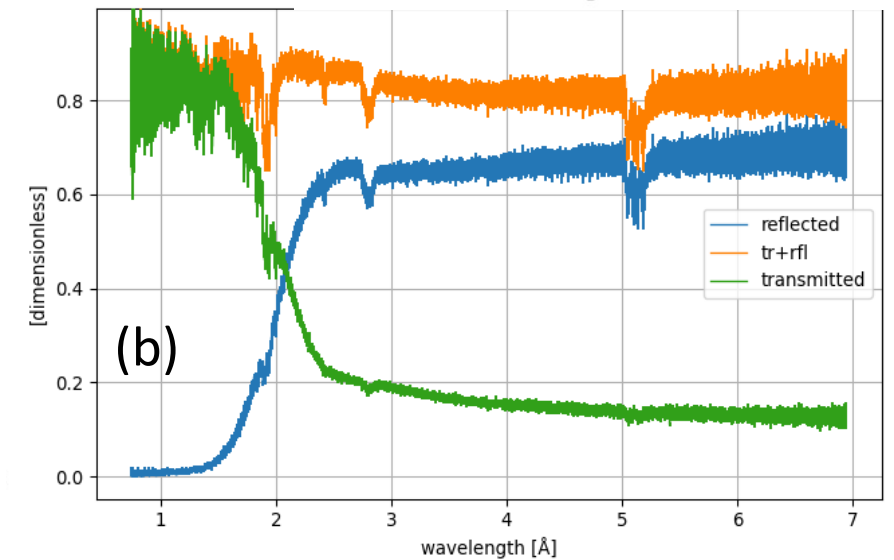
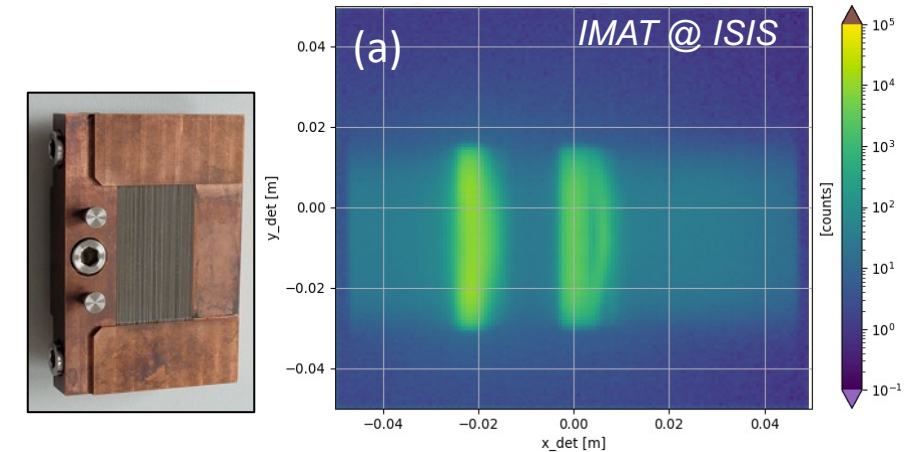

- NBOA is integrated into NBPI
- Bi-spectral switch was assembled at FZJ
- Neutron tests of the switch at ISIS completed in July 2022
- Vitess/McStas simulations of the results are ongoing
- More beam time with improved mechanical assembly & for publication

Chopper system

Pulse Shaping Chopper (308 Hz) & Overlap Chopper (14 Hz) Band Control Chopper (112 Hz)

- Vendor: Jülich Chopper Group
- Disks are manufactured (Airbus)
- Housings & bases are manufactured (FZJ)
- Commissioning at SKF has been resumed
- Chopper bases will be shipped to ESS in Q4 2022
- FAT of entire assembly (OC + PSC + hub) in FZJ
- Planned delivery in Q1 2023

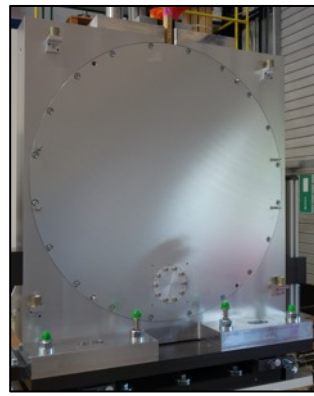
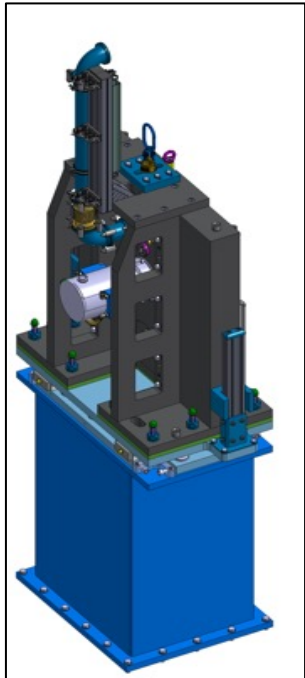
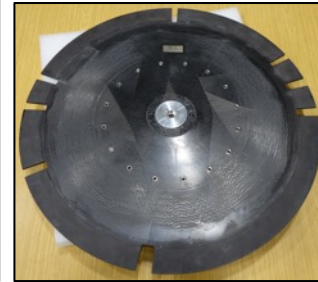
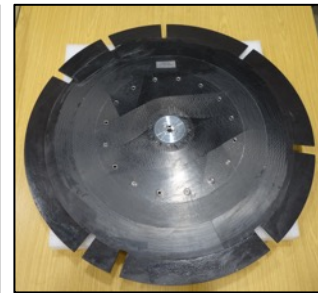
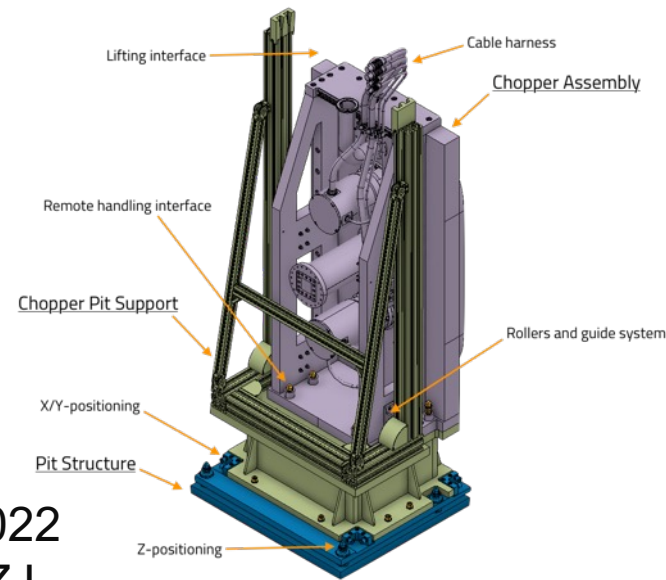

T0-Chopper (ESS)

- Manufactured
- FAT in September 2021
- SAT is complete
- Installation Q4 2022



Chopper tests at SKF

- Chopper disks and housings were delivered to SKF for final assembly & tests
- BC chopper reached target speed of 112 Hz
- Failure of the hub was observed during the endurance tests
- Further tests were halted
- Disks delivered back to FZJ
- ESS Chopper group was informed



Update

- Most likely explanation: human error
- New hub was delivered from Airbus
- First tests with new hub are successful
- New plan for the final FAT:
 - PSC + SKF spindles + housing shipped to FZJ
 - All of these + OC with FZJ spindle is tested
 - After FAT system is shipped to ESS

Heavy shutter (ESS)

Shutter block composition

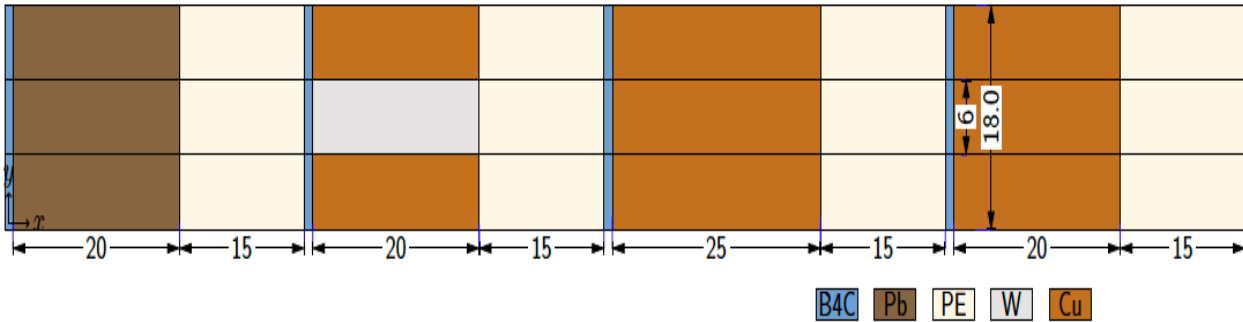

- Neutronics simulations are done by FZJ
- FAT of mechanical parts was accepted in August 2021
- Manufacturing is completed
- Installation: Q4 2022

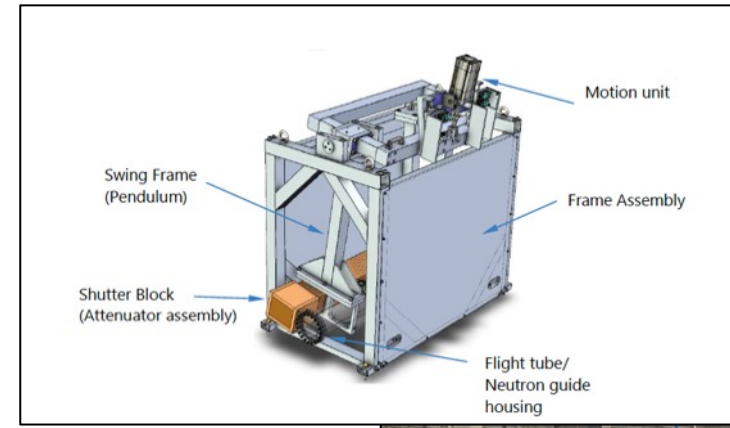

Neutron guides

- SubTG3s for in- & out-of-bunker are completed
- In-bunker guides manufacturing is ongoing
- Additional reinforcements on vacuum housing (nothing critical)
- FAT of both in-bunker & out-of-bunker guides at SNAG in Q4 2022
- Installation: Q2 2023
- Interface with ODIN cave, which was delayed

Last section (mock up for field tests)

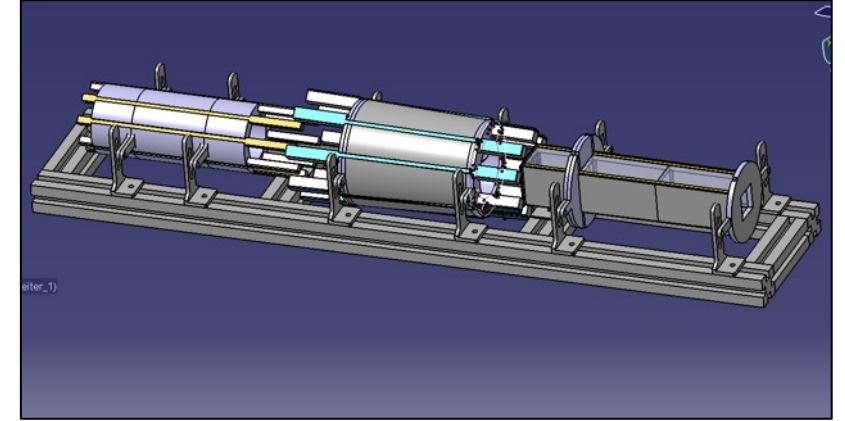

Inside bunker

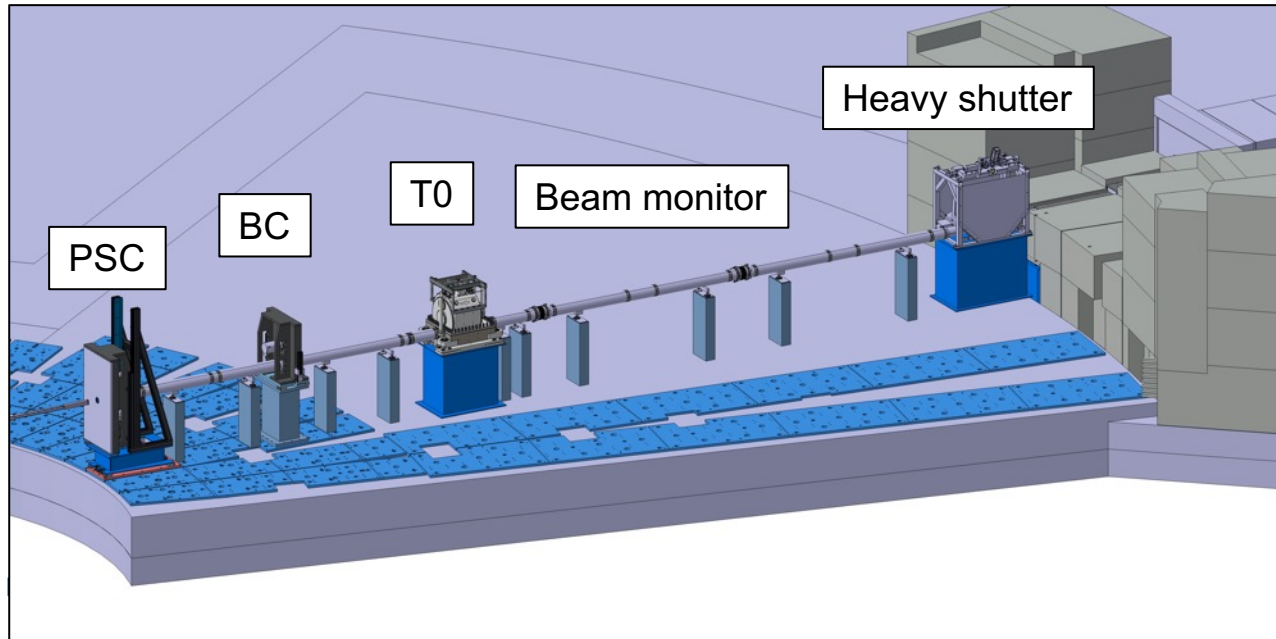

Outside bunker

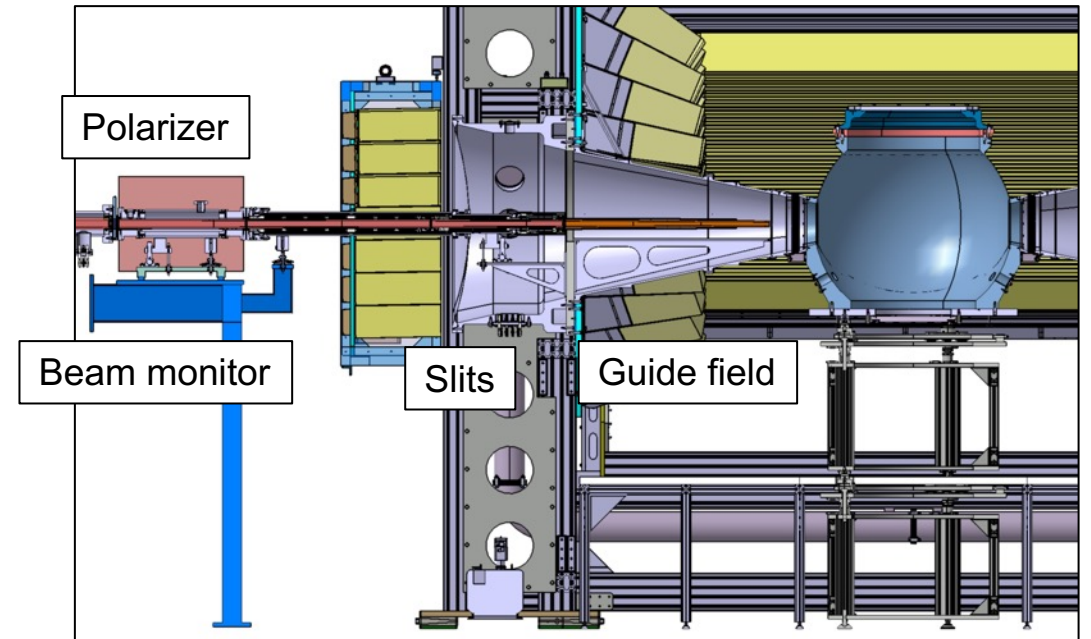

Detector support

- Installed at ESS
- Tests with mantle frame



Mantel detector support

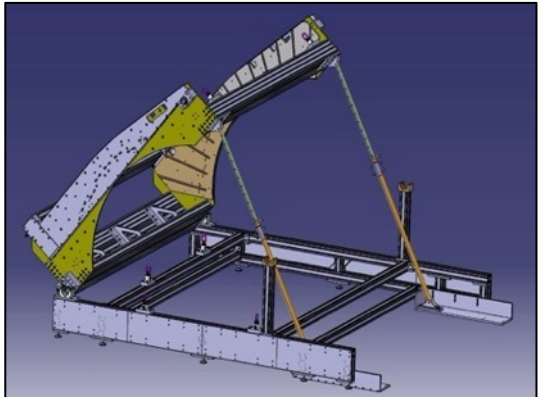
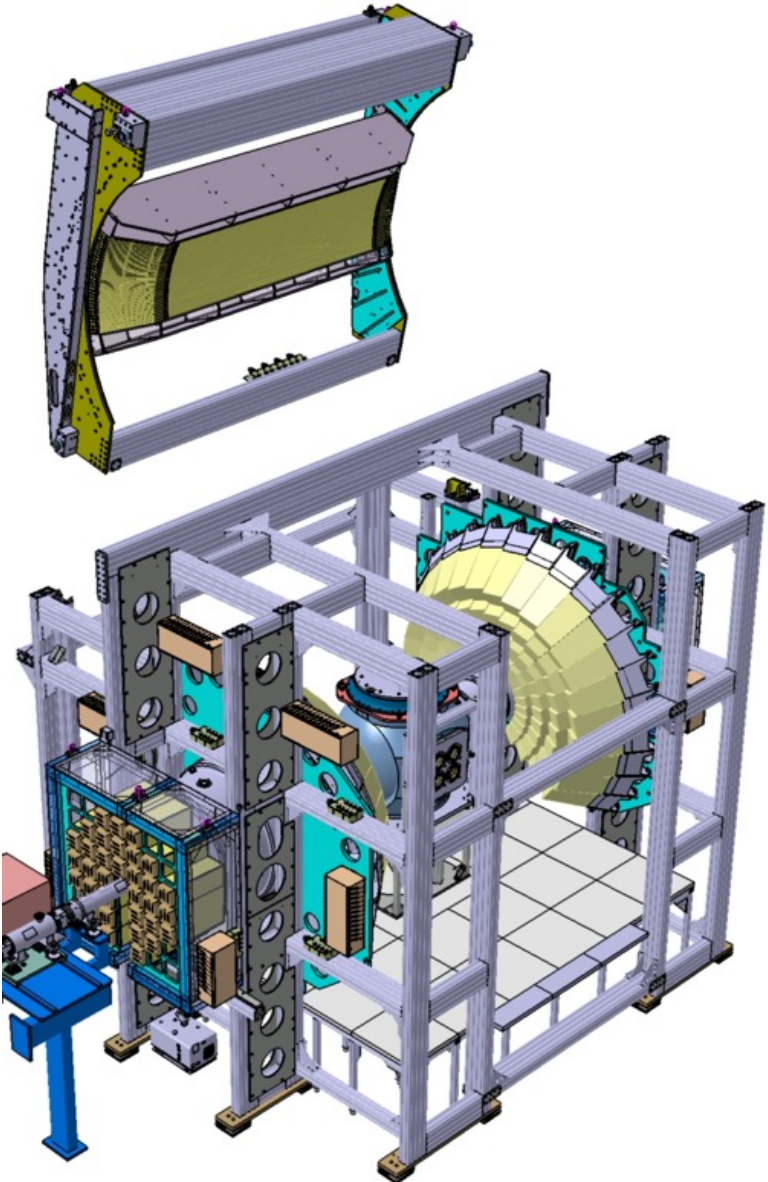

Loading mantle "detectors" with hall crane



Loading mantle frame to the cave



Media frenzy

← **Tweet**

 **Gudrun Lotze**
@gudrun_lotze

Like a village, various experimental stations are scattered around the target accommodating the end stations. Here the neutrons will hit the samples. You can see Dream which will carry out diffraction experiments. @essneutron #neutrons4europe



8:21 PM · Oct 5, 2022 · Twitter for iPhone



European Spallation Source ERIC

3w · 🌐

The 20th Instruments Collaboration Board (ICB) meeting was held at ESS last week. The meeting was held in hybrid format, with those able to attend in person being given a tour of the facility. It was the first chance most of them have had to see the progress first hand since 2019. The tour included a look inside the DREAM instrument, a walk around the ESS site, and a peak in the ODIN bunker. The ICB is chaired by Marc Janoschek from the Paul Scherrer Institute in Switzerland, and comprises representatives of the 15 partner institutes working together with the NSS Project Division and Science Directorate to develop and build the initial neutron instrument suite at ESS. (Pictured: Marc Janoschek ([Paul Scherrer Institut PSI](#)), Tania Claudio-Weber ([Forschungszentrum Jülich](#)), Andreas Wischnewski ([Forschungszentrum Jülich](#)), Felix Villacorta ([ESS Bilbao](#)), Sean Langridge ([STFC - ISIS](#)), and Niels Bech Christensen ([DTU - Technical University of Denmark](#)), along with ESS staff: Andrew Jackson, Group Leader Instrument Scientists, Mikhail Feygenson, DREAM Instrument Scientist, and Manuel Morgano, ODIN Instrument Scientist)



Sample vessel & support

- Installation at ESS is completed
- Leak tests are successful
- Stored in the hutch

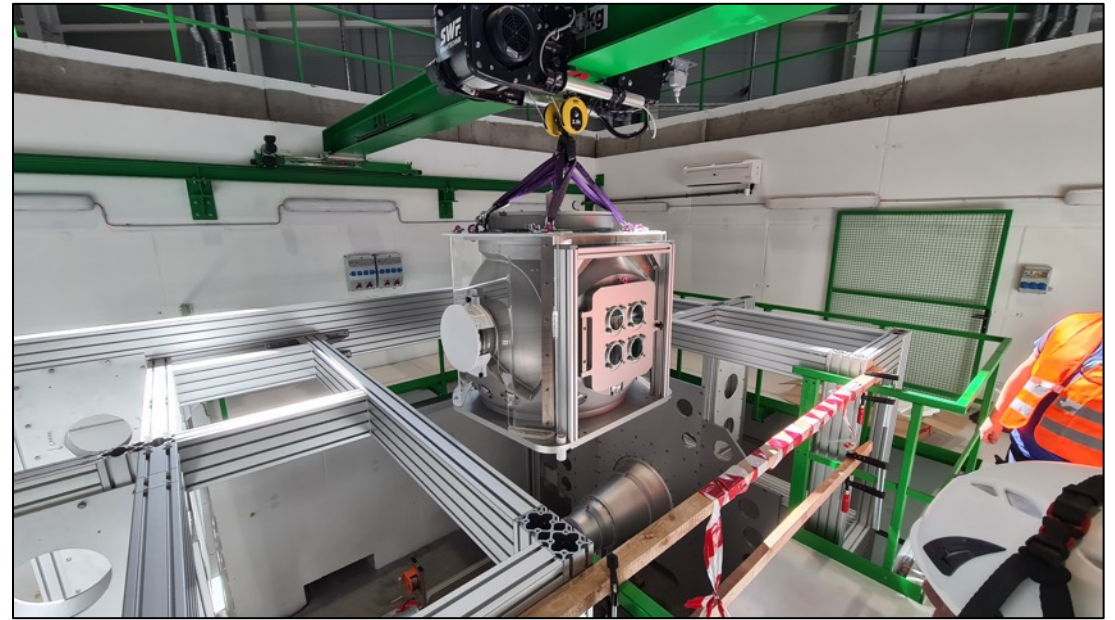
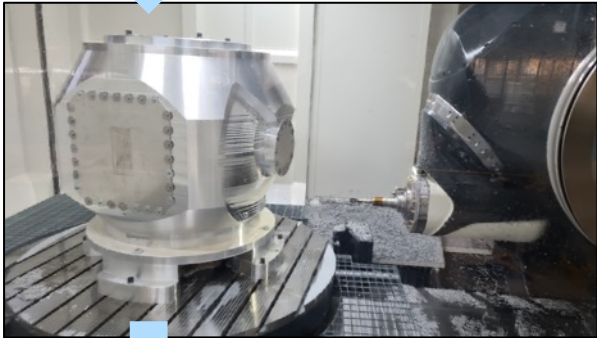

Detectors

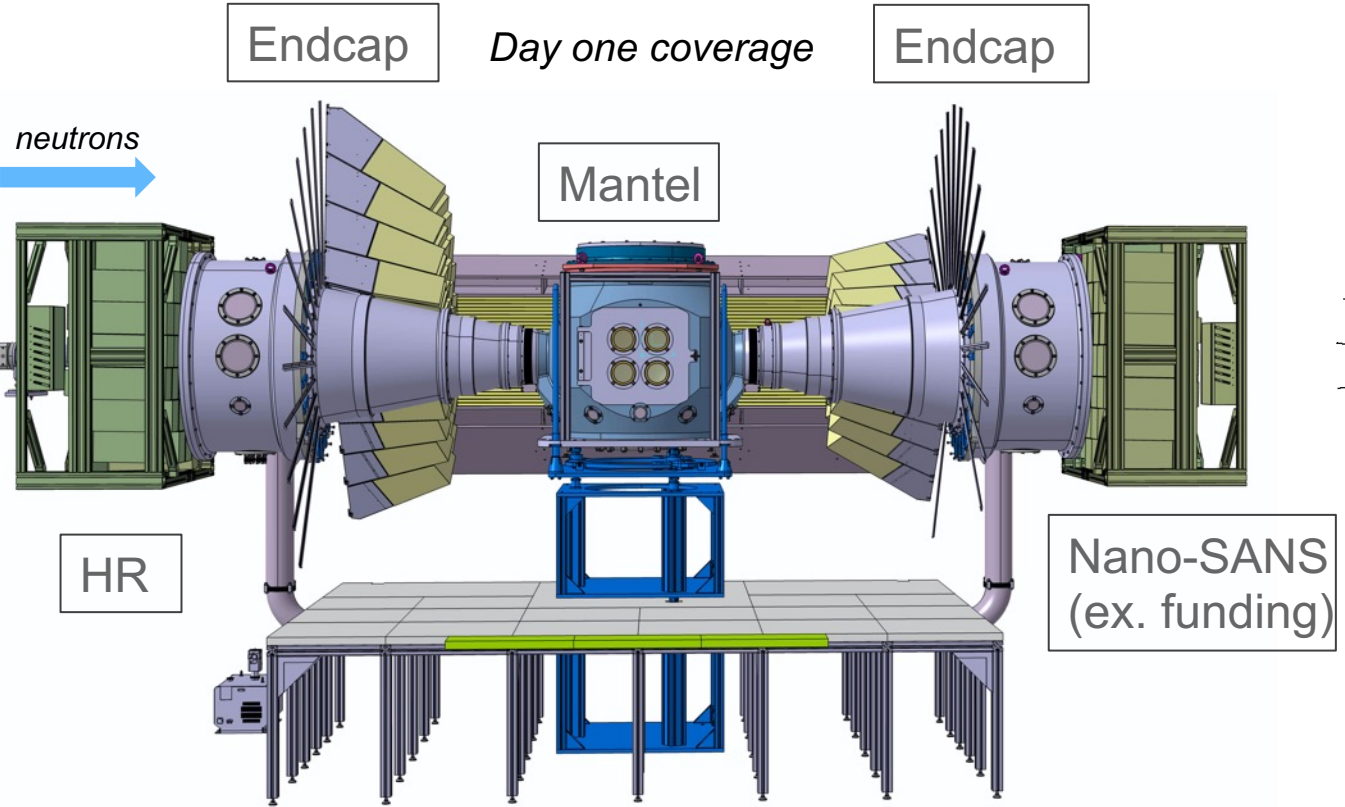

Provider CDT GmbH
Prototyping of first segments (0-series production)

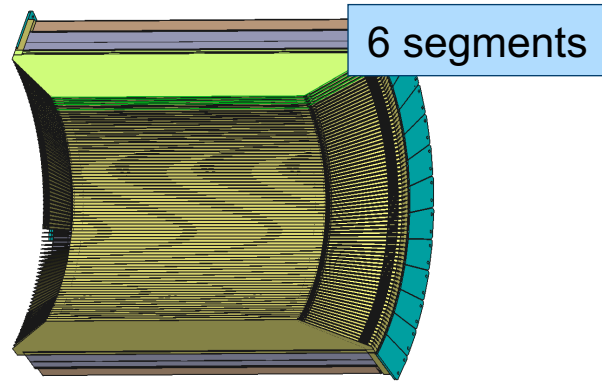
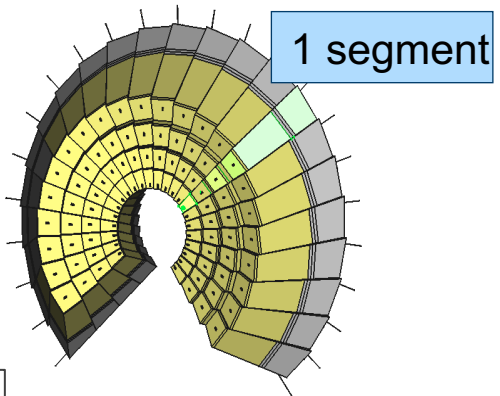

- Endcap & mantle first segments are successfully tested with neutrons
- Endcap: prototype is done, serial production ongoing
- Mantel: prototype is done, serial production ongoing
- First modules delivered at ESS in March 2023 (avoid shipping in winter)

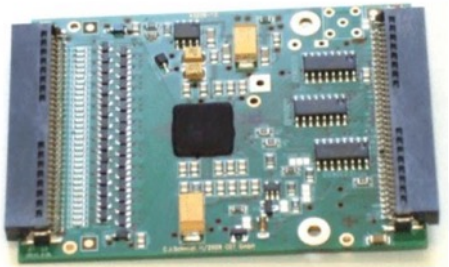
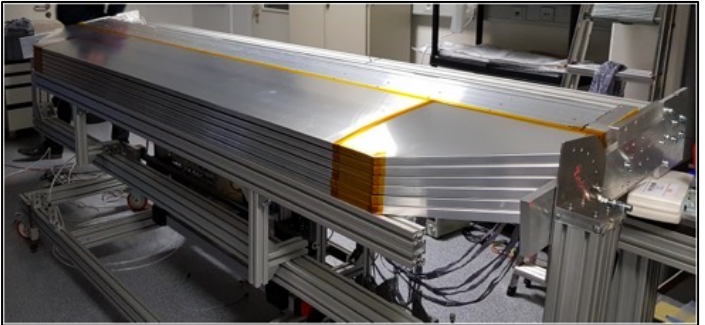

Control hutch & sample preparation lab

- Installed at ESS, pre – SAT is completed
- Inspection from quality is requested by ESS
- Interface with CUP & CEP
(patch panels, network)

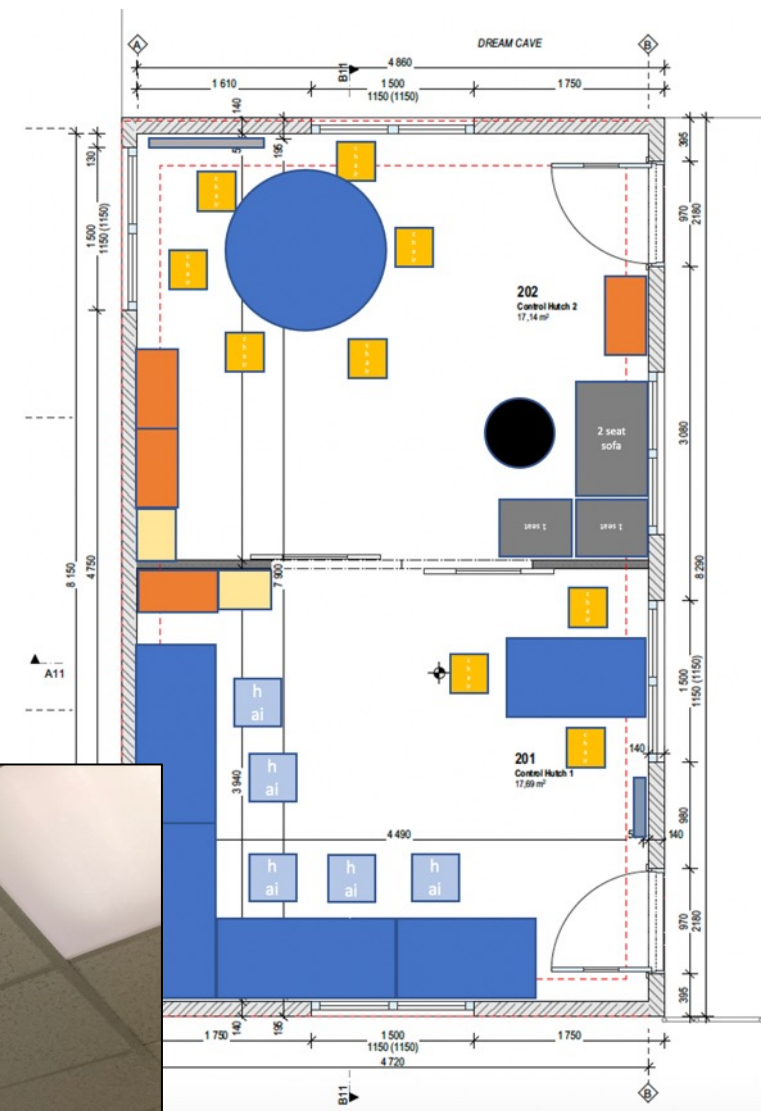

Experimental cave

- Installed
- Finalizing CEP & CUP & PSS requirements
- Discussion with SAD about patch & gas panels



Cave crane

Beam stop in 2nd cave



DREAM Specific SEE: Cryofurnace with Sample Changer



- T = 4 - 800K
- 20 samples
- Flange & floor mounts
- Similar solutions exist

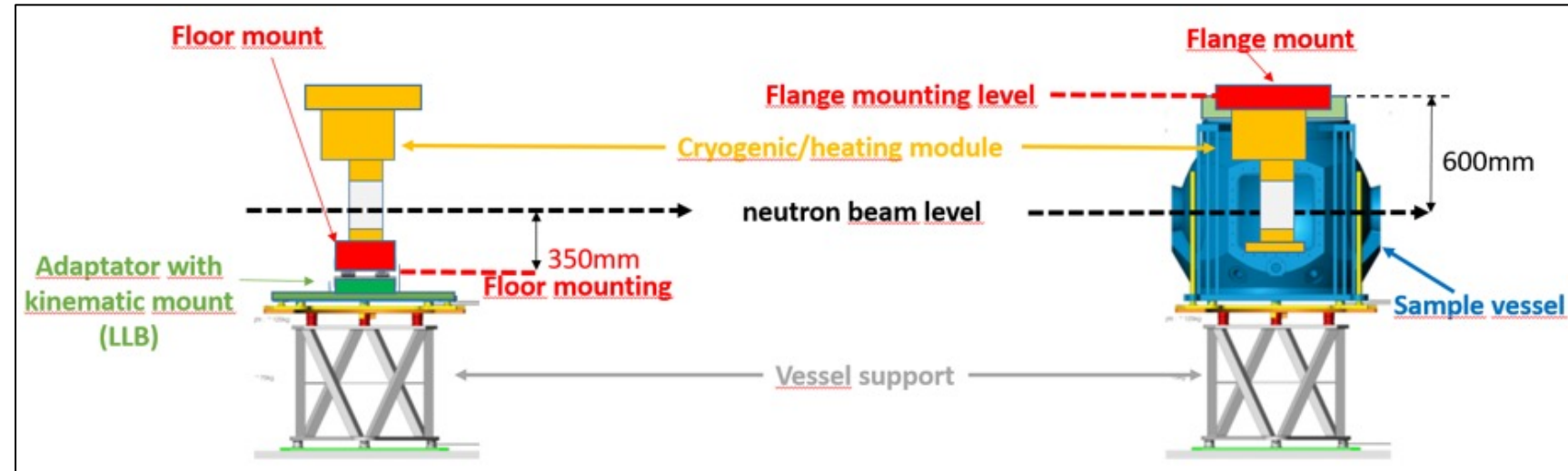

- 4 unsuccessful tenders
- 2 requirements were relaxed (longer cooling time, sample position measurement along 3 axis with accuracy < 1 mm)
- Scope transfer to ESS agreed (last ICEB)

SEE delivered to ESS	Sample vessel & support Installed	Detectors Installation completed
?	Aug. - 2022	Q4 - 2023

Transferring SEE scope to ESS



- Official agreement with ESS Sample Environment group (resources)
- MF & FP will do all the legwork
- Presentation at Sample Environment STAP (blessing received)
- Meeting with ESS Head of Procurement (MF)
- “Contract management at ESS” training (MF)
- Article 16 of ESS: direct procurement from a company
- Same company started the contract with POWTEX @ FRM-II

Alternatives

- Revised CTV (lessons learned)
- Agree on using Article 16 or not
- Consider alternative solution (visit to ISIS)

ISIS robotic arm (<300 K)



Linear sample changer (SNS, 90 – 500 K)

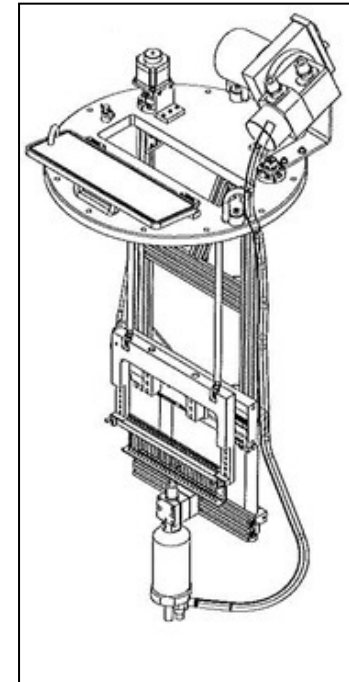

Cryo-jets & heat guns

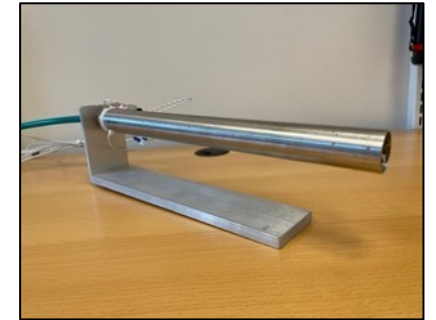

Other updates

- Quote for CEP was accepted
- Common shielding: 100 % blocks manufactured, 25 % delivered
- Instrument hazard analysis is completed
- PSS ConOps are under review
- Integration meetings between CEP, PSS, CUP
- TG5 is scheduled for December 2023



Issues

- Delay in Final TG3 (clarifying ESS requirements)
- Cryofurnace procurement delays
- Some delays with SAT of hutch and cave (nothing critical)