

CSPEC STAP report April 2023

D. Noferini, P.P. Deen, W. Lohstroh, S. Longeville, F. Moreira, M. Olsson, G. Tucker.

CSPEC is the cold chopper spectrometer at the ESS. CSPEC TG5 (final ESS internal review, corresponding to the end of construction phase) is currently planned in November 2025. CSPEC is expected to match the performance of current World leading instruments of its class in about 2 years from the ESS beam on target. The science case for CSPEC is very broad and will satisfy many different communities such as magnetism, soft matter, energy materials, life science. CSPEC has a strong focus on small samples, in situ and operando, kinetics etc. A few examples of the science case of the instrument include: collective and quasiparticle excitations in frustrated compounds; low lying excitations in quantum matter; magnon -phonon hybrid excitations in multiferroic materials; time dependence of the rotational and translational diffusive processes in enzyme catalysis; dynamics of hydration processes and the structural relaxation of the glassy water; time dependent phenomena of hydrogen storage in clathrates; proton diffusion in metal organic frameworks; operando studies of proteins such as those involved in photosynthesis.

In this STAP report, we provide an overview of the status of the main components.

Guides and housings

NBOA and BBG (first guide elements): NBOA installed, inspection on site completed for BBG. BWF (bunker wall feedthroughs) installed. TUM guides: arrival on site of ca 90 m of out-of-bunker guides; ca 58 m are released for manufacturing; ca 2 m are currently under design. The installation is still an open point and we are considering different solutions (e.g. outsourcing it to specialised companies).

Design work is ongoing for the in-bunker guide housings and supports. All the out-of-bunker housings and supports have been produced, delivered and accepted.

Shielding (common project)

All the shielding blocks for the primary spectrometer have been produced. Installation is in progress.

Choppers

The manufacturing by Airbus of the chopper blades and main structures is progressing well, as well as the testing. After some tests at 385 Hz on the M-chopper test-blade, it was decided to reduce the maximum operational speed from 350 Hz to 336 Hz. This decrease will allow reducing the testing overload speed on the final discs, and thus the risks of possible failures which could severely affect the schedule. The change will not affect the expected scientific output of the instrument. TG3 is planned for April. FAT is expected in September-October 2023. Design work is ongoing for the chopper supports and housings.

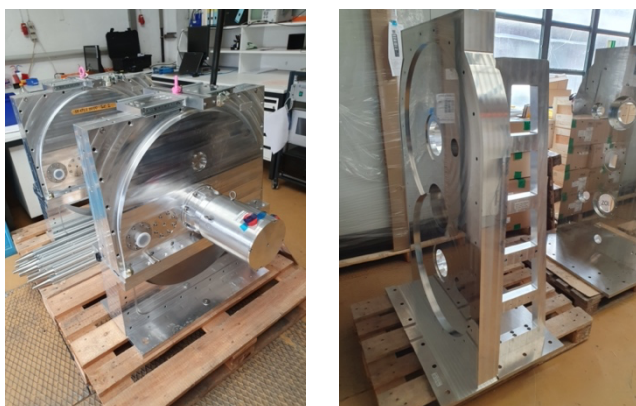

Figure 1 Manufacturing of the CSPEC choppers at Airbus.

Radial oscillating collimator

Manufacturing is almost completed at JJ-Xray. The collimator drive internal design will be developed internally (LLB) and is lacking manpower (see staffing level).

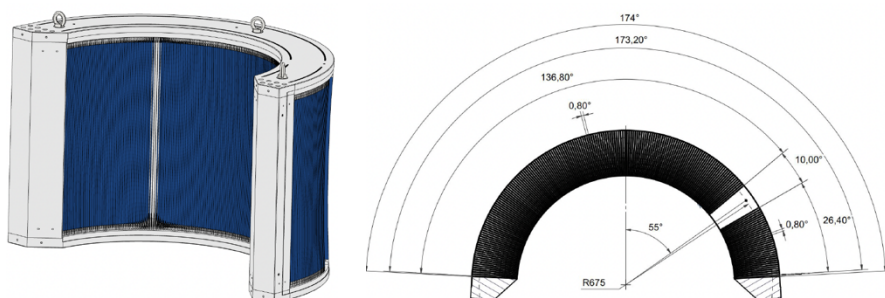

Figure 2 Radial oscillating collimator 3D model (left) and overall dimensions (right)

Cave

The tender for the cave was closed at the end of March. We are currently evaluating the offers. The control cabin, the instrument crane and the false floors for the racks were not part of the current tender and will be out for tender separately in the next future.

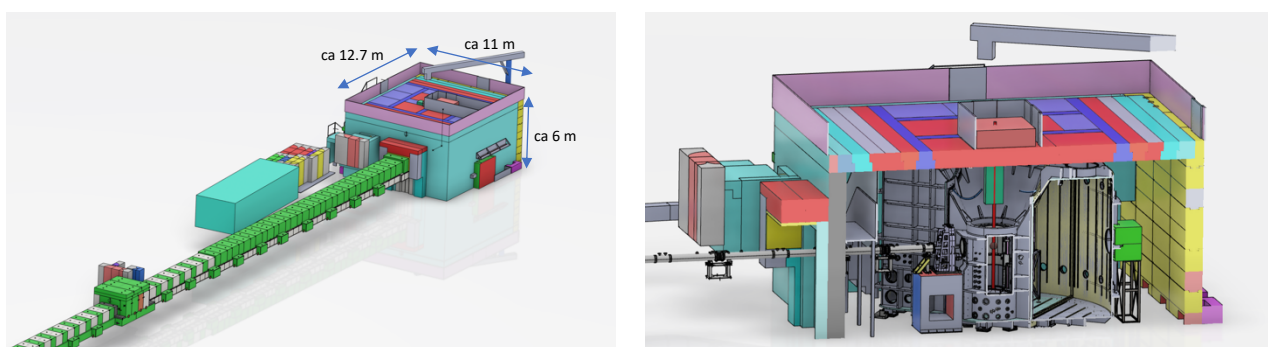

Figure 3 Overview of the cave and control cabin (left) and cut of the experimental cave (right).

Detectors

The CSPEC team, with the ESS detector group and NSS management, are working to finalise an agreement with the ILL for a collaboration aimed at the delivery of ^3He Multitube detectors (MT) for CSPEC. The details are currently under discussion. The MT with the option of flexible selection of ^3He pressure (as in PANTHER@ILL) is the solution that the CSPEC team identified as the preferred alternative (see CSPEC STAP report October 2022). This was confirmed by a panel of detector experts [D. Raspino (ISIS), B. Guerard (ILL), K. Nakajima (J-PARC), K. Berry (SNS)], during a review held in January at the ESS.

[<https://indico.esss.lu.se/event/3189/overview>]

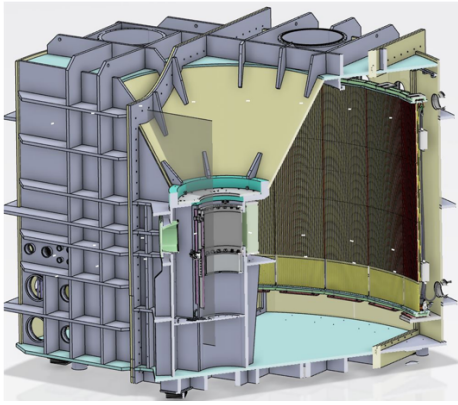

Figure 4 Cut of the CSPEC detector tank with a preliminary model of the MT.

Detector tank

The detector tank manufacturing with SDMS is progressing well. The tank was modified to allow the change of detector technology. Installation is expected in April 2024.

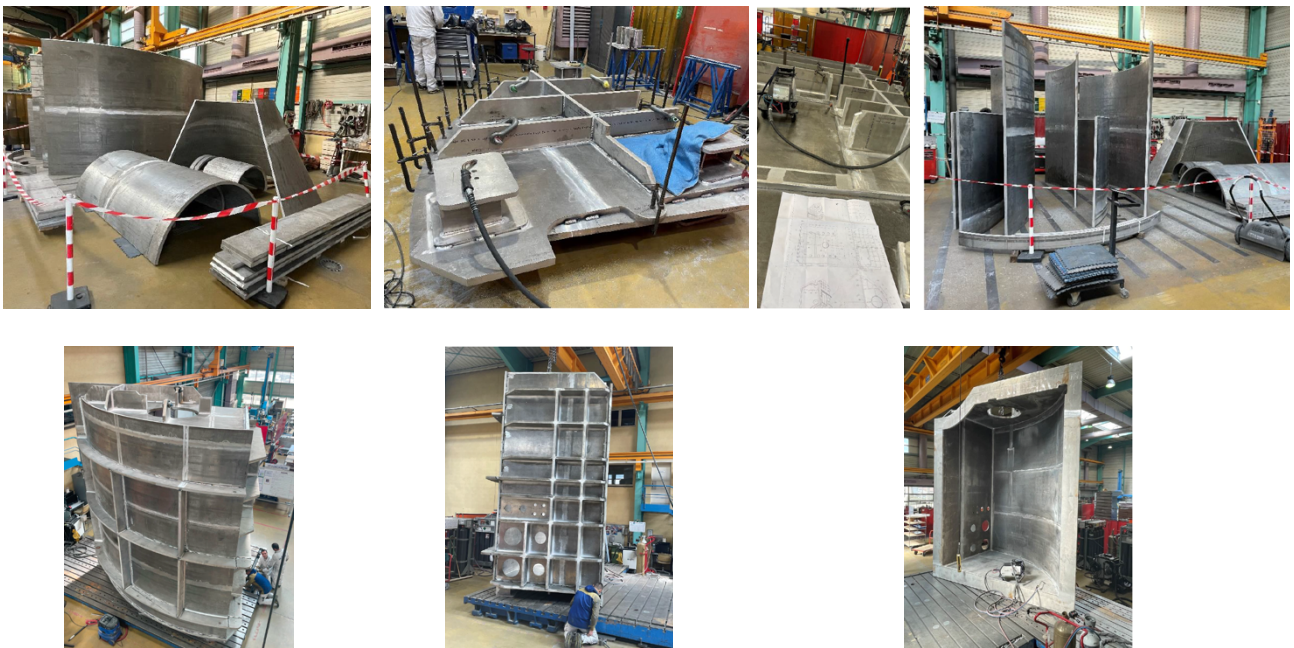

Figure 5 CSPEC tank manufacturing at SDMS. Updates from February (up) and April (bottom)

The design and procurement of the cadmium sheets and the polyethylene blocks for shielding will be done shortly.

Data acquisition, transformation and analysis

See report by G. Tucker.

Sample environment

The tender for the cryofurnace is to be published shortly. A kick-off meeting for a 10-14 T spectroscopy magnet to be used on CSPEC and TREX was done at the end of February. For the hot commissioning we plan to have ready the cryofurnace, the rotation stage and the ^3He insert.

Beam Monitors (common project)

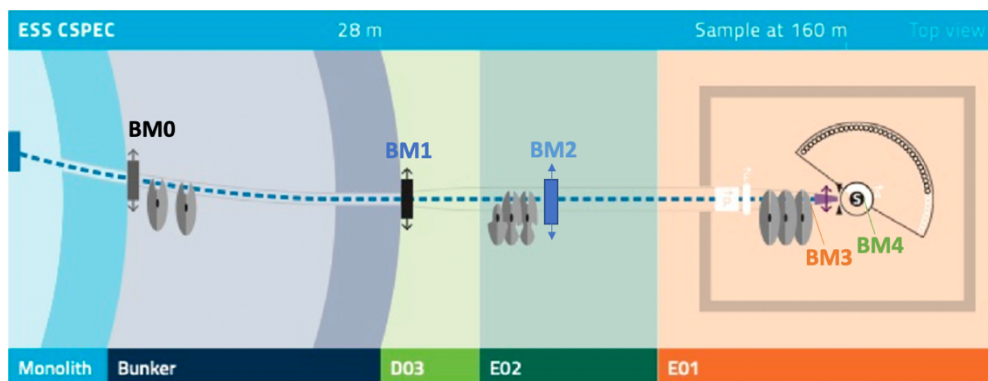

Figure 6 Sketch illustrating the location of the beam monitors (BMs) for CSPEC

The solutions currently envisaged for CSPEC within the common project are:

BM0 (in-bunker): ionisation beam monitor (IBM), CDT Germany.

BM1-BM3: micromegas (MM), CEA, France.

BM4 (after sample): neutron camera (+ monitor from the common pool during commissioning and maintenance).

The technologies were proposed to match the requirements of low background (for the fixed ones, BM0 and BM3) and coverage of a large dynamic range up to high rates, within a timeline compatible with that of the instrument. BM0 needs also to be robust in a challenging environment and to provide a very good gamma discrimination and the IBM is promising concerning these aspects. The neutron camera, assisted by a monitor (e.g. GEM) from the common pool of the detector group during commissioning and occasional maintenance, is seen as a good and inexpensive solution for post-sample position, where we need mostly a good 2D spatial resolution and an estimate of the transmitted beam.

Tests on IBM were planned at EMMA@ISIS in May. Due to the problems at ISIS-TS1, the tests are now moved to Morpheus@PSI (5 days) in June. On-going planning of radiation hardness tests (end of 2023).

Prototypes for MM are expected in October 2023 (including the electronics). Tests at suitable beamlines will follow.

Electrical installation and utilities installation (common projects)

Detailed design for utilities and electricity is ongoing. This will be the basis for a kick-off meeting with the ESS electrical team. For the utilities, the discussion with the ESS technical team will start after the first model of the cave provided by the supplier.

Staffing level

In the last report, we flagged the problem of the lack of engineering resources. Mats Olsson, TUM design engineer based in Lund, is now integrated into the team. Recruitment is ongoing for an LLB design engineer, to be based in Lund. Depending on the timelines to reach an agreement, end of previous employment, relocation, and possible work-permit, we forecast a starting date in the next 2-5 months. The guide exchanger, collimation slits, sample environment support stack, and collimator driving system are currently on hold and waiting for the new design resources.

Daria Noferini plans to be on parental leave in the period June 2023-January 2024 (included). Pascale Deen will be acting lead scientist during this period.