

MAGiC progress report

April 2023 STAP meeting

This report highlights the progress and changes made on the MAGiC instrument since the last meeting in October 2022.

1. Project management

Instrument review meeting with ESS

An instrument review took place on the 13th of December. Discussion was on:

- Components design
- Status of procurement
- Installation plan
- Urge to start work on site as quickly as possible
- Status of the collaboration

Personnel

- 1) A MAGiC engineer has been hired for 3 years on-site by ESS. This is a senior engineer with 20 years of experience with background in fusion technology. Start date is estimated to 20th of June 2023 to accommodate for all administrative procedure.

The on-site engineer will work on:

- a. the design of the remaining components,
 - b. the TG3/TG4 documentation
 - c. installation activities on-site
 - d. interaction with ESS technical groups
- 2) A CAD designer has been hired at LLB to help on the design of the most critical components (in-Bunker and Bunker wall components). Start date was on the 17th of April 2023 for 2 years.

2. Progress on individual components

NBOA

The NBOA (first element of the instrument inside the monolith) has been delivered and measured on-site. Specifications are reached and installation can be performed.

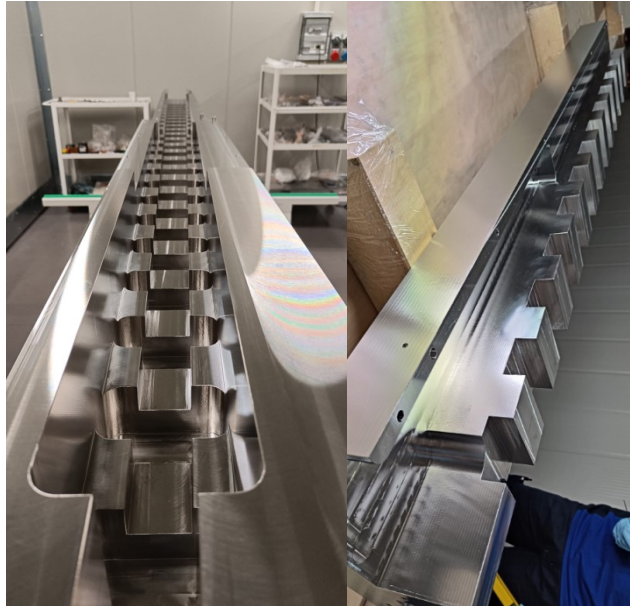

Figure 2.1: (left) bottom part of MAGiC's NBOA. (right) top cap of MAGiC's NBOA

Solid State Bender

Work on the alignment procedure and integration has started at LLB. This is a more complex task than anticipated which is now prioritized to ensure proper installation in-Bunker.

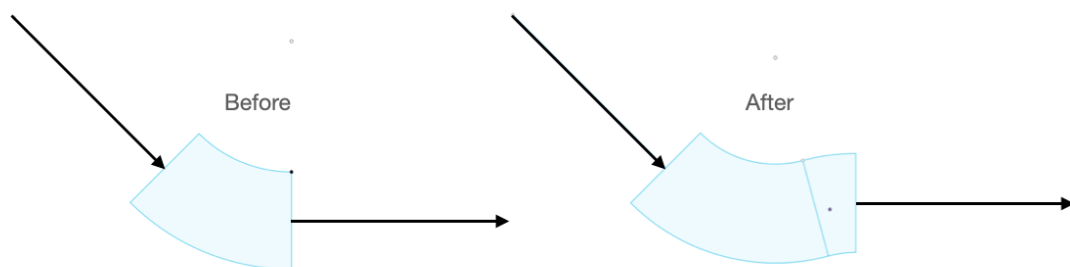
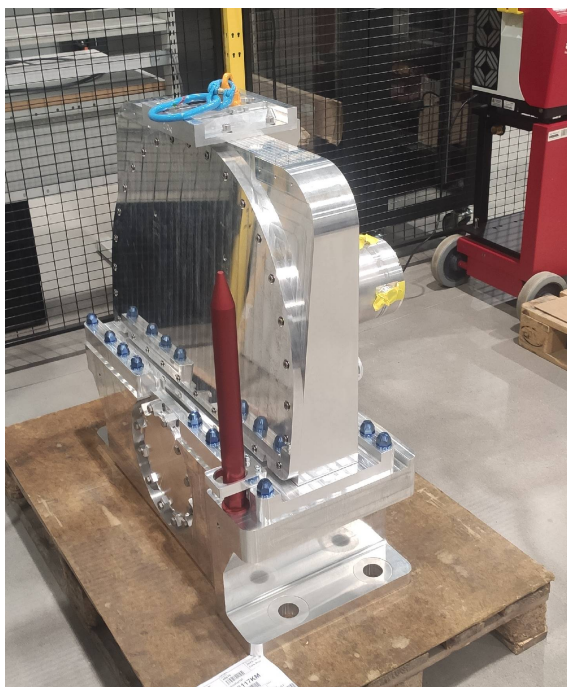

Figure 2.2: geometrical change of the SSB to maximize polarization at large wavelength.

Choppers

- The LLB components (magnetic guide field) have been integrated to the front-end chopper. Minor correction have been made to finalize the integration and everything works as expected.
- All chopper sets are assembled on-site.
- SATs are scheduled in May.
- Installation will follow later in 2023.



Neutron Guide system

In-Bunker: delivery delayed as measurements performed in February were unsuccessful. A new campaign is in progress for an assembly in May.

BWI: delivery delayed as measurements performed in February were unsuccessful. A new campaign is in progress for an assembly in May.

Out of Bunker: latest progress report confirmed a delivery date of the first guide elements in July 2023. The second half will be delivered in October 2023 as expected.

Polarizer: sub-TG3 has been validated. Procurement of materials is in progress for a delivery in December 2023.

Vacuum Housing

The in-Bunker section of the vacuum housing is under review before producing the manufacturing drawings. The new CAD designer will dramatically help finishing this part of the project.

The out of bunker Guide Vacuum Housing will be designed based on the IB ones at a later stage.

Collimation slits

Documentation for the sub-TG3 has been uploaded to Confluence on April 11th. Feedback expected on the 25th of April.

Integration with the guide system has been discussed with Mirrotron. The installation plan allows for a delivery of all components to ESS prior to assembly.

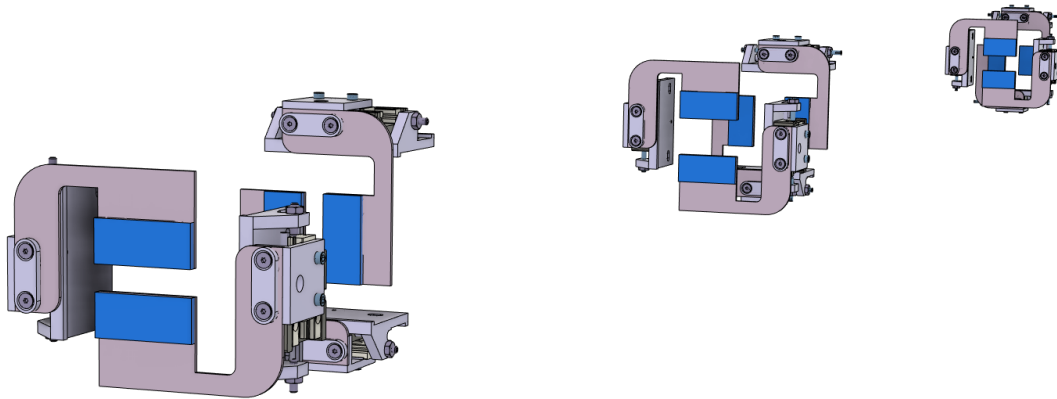

Figure 2.3: MAGiC's collimation slits system. The 16 slits will be installed on the guide system at the end of 2023.

Heavy Shutter

Manufacturing is now complete and the FAT have been performed at LLB.

Performance are better than specifications with:

- Positioning repeatability: ± 0.005 mm in open position (guide in beam) and ± 0.04 mm in closed position (attenuating block in the beam).
- Opening time : 7.8 s
- Closing time : 6.9 s

A last step is required to integrate the limit switches for operation and PSS.

Once done, the shutter will be sent to ESS for installation.

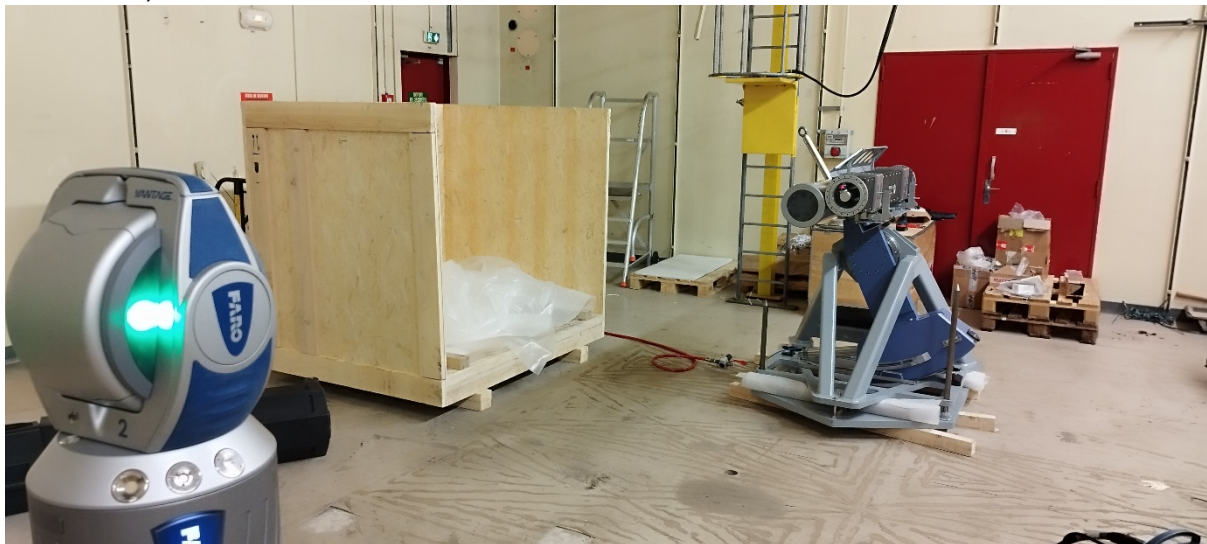

Figure 2.4: Metrology using Faro laser tracker of the HS positioning during FAT

Detectors

Sub-TG3 for Detector A has been validated.

Detector A production is scheduled in the first half of 2024.

Following the last STAP meeting, discussion has started between the ESS Detector Group and CDT to send the Detector B modules to Lund (current estimate is May). The master module is now available and integration can start with the help of a CDT representative. This is the first step towards hot commissioning of the detectors.

Analyzer

- The IDR held to validate the tendering of critical materials (magnets, steel and silicon wafers) was a success.
- Documentation for the sub-TG3 has been uploaded to Confluence on April 18th. Feedback expected on the 2nd of May before manufacturing can start.

XYZ field / guide field at sample position

- Magnetic field and coil system design is now done.
- Design of the holding structure is in progress.
- Documentation for the sub-TG3 has been uploaded to Confluence on April 18th. Feedback expected on the 2nd of May before manufacturing can start.

Variox cryostat

Documentation for the sub-TG3 has been uploaded to Confluence on April 18th. Feedback expected on the 2nd of May before manufacturing of the tail can start.

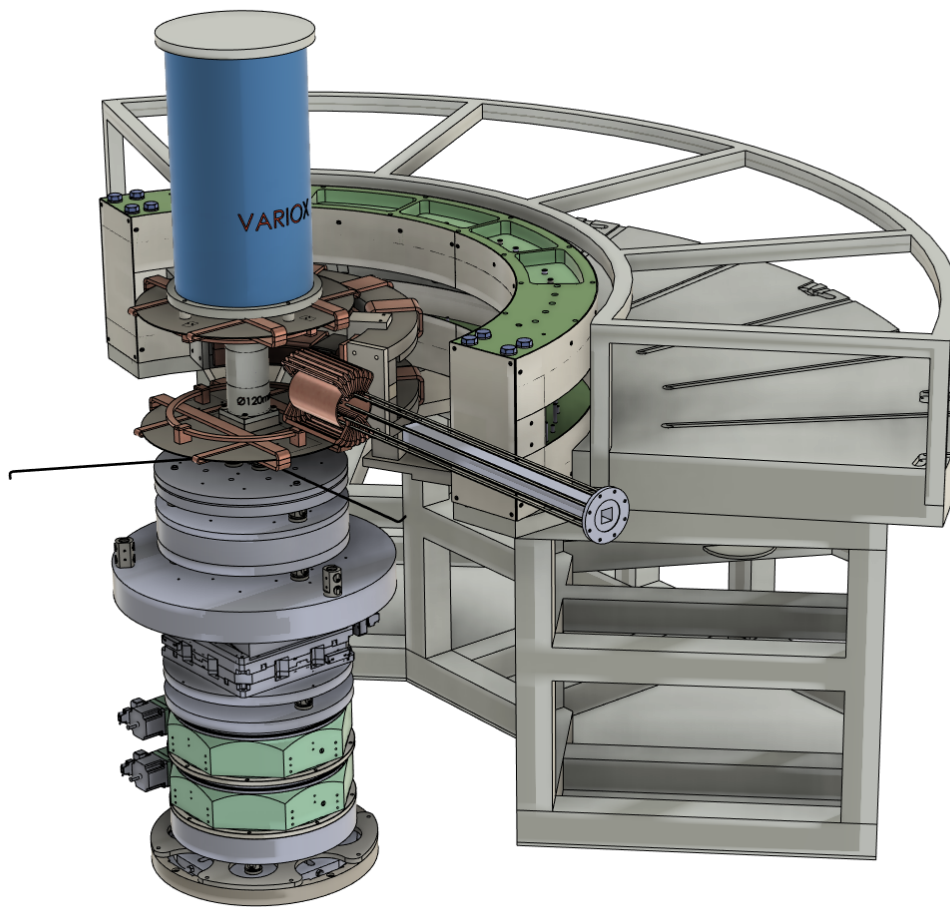

Figure 2.5: Variox cryostat, XYZ magnetic field and polarization analyzer in position on the Detector B support table and sample station.

Experimental Cave

Detailed design of the experimental cave and control hutches are now completed:

- Mshield is working on the engineering documentation.
- LLB is compiling the neutronics report.
- Sub-TG3 documentation to be sent on May 10th for a meeting on the 26th before manufacturing can start. This is 3 weeks earlier than planned.
- The installation plan still holds.

The stairs to access the cave roof have been modified to accommodate for Miracles close proximity. The Miracles cave is on the forklift path and its footprint cannot be reduced.

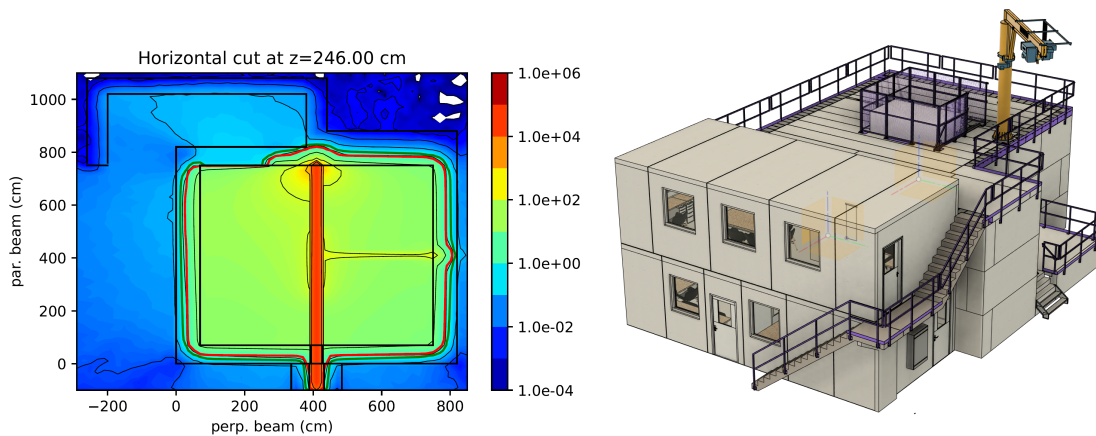

Figure 2.6: (left) dose rate at sample height in the case of a Bragg reflection hitting the closest wall. (right) Detailed designed experimental cave render

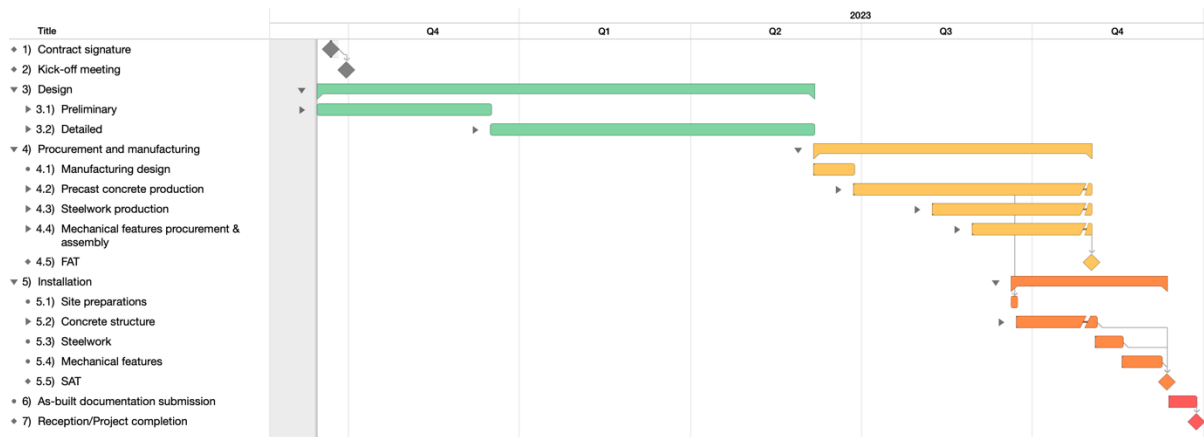

Figure 2.7: Experimental cave schedule

Elevator

A french company made an offer for the instrument elevator.

Discussions are in progress to ensure it meets the NSS requirements and can be operated easily.

The main difficulty is the 20 cm step to enter the platform at ground level. It requires an access ramp that cannot be installed permanently due to the forklift pathway.



3. Updated timeline

The instrument timeline has been strongly impacted by:

- Delay in Bunker access to August 2023 and extended opening period
- Delay in guide elements delivery up to December 2023

TG5 without the Analyzer is now scheduled in October 2024. The delivery of the first analyzer sector (~33%) is now expected in January 2025 postponing the global TG5 to March 2025.

The instrument will still be ready for beam on target. A hot commissioning phase of one year will then be possible while ramping up the accelerator.

To achieve this, cold commissioning will be performed in parallel with installation to benefit from any downtime in handling activities.

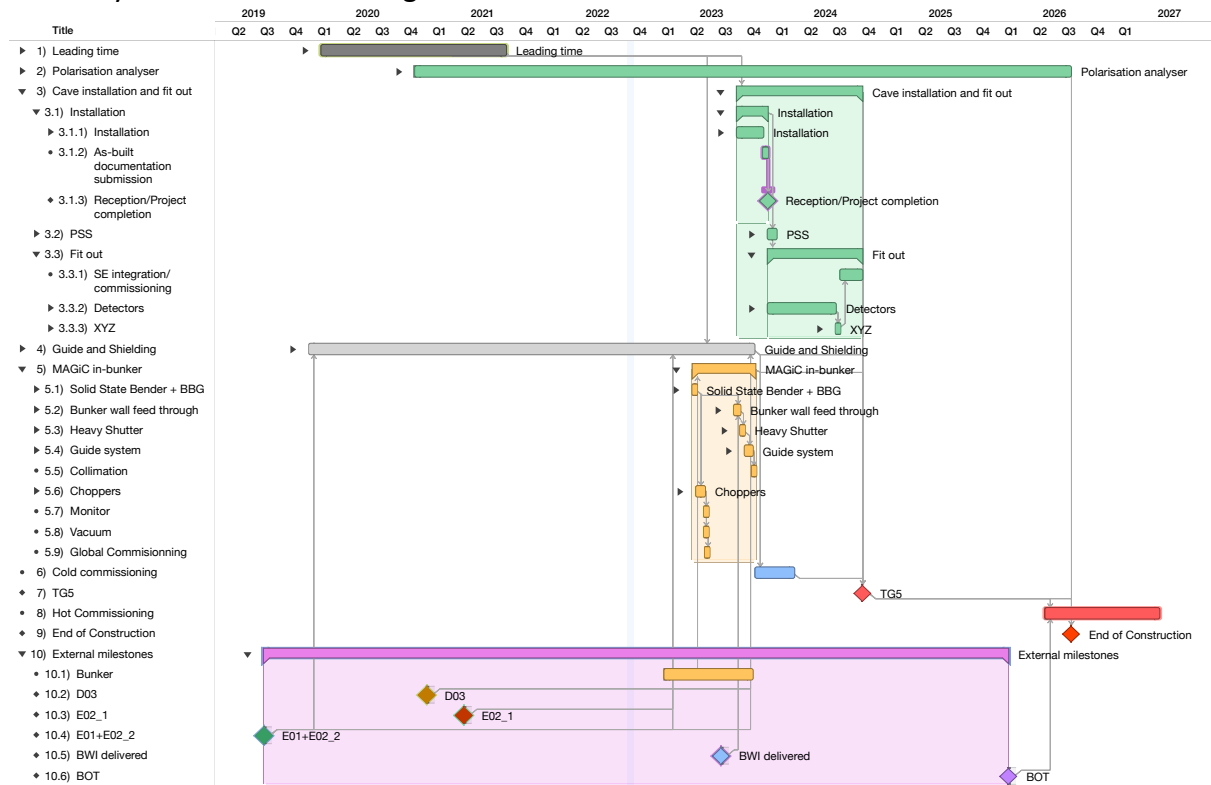

Figure 3.1: updated MAGIC's installation plan