

# Engineering Days, 2-3 June 2015 - ESS Detector Group

Michail Anastasopoulos

Lead Design Engineer  
on behalf of Detector Group

# ESS Detector Group

## Who are we, what we (want to) do

- Support and facilitate partners to be able to deliver performant detectors for world class instruments
- Act as a host institute to assist and enable in-kind partners to deliver where requested
- Facilitate installation and commission detectors
- Operate and maintain detectors throughout their lifetime

**Support - Enable - Integrate**

- Interface management for in-kind partners with other parts of NSS and ESS and other in-kind partners
- Integrate detectors into a homogeneous ESS instruments suite
- Where necessary, assist in the design and development of detectors with partners for partners
- A technology service group capable of long term support



## Detector responsible (per instrument)

Instrument Class	Instrument	Detector Contact Person
SANS	LOKI	Kalliopi Kanaki
SANS	SKADI	Kalliopi Kanaki
Macromolecular Crystallography	NMX	Dorothea Pfeiffer
Imaging	ODIN	Tomasz Brys
Direct Spectroscopy	VOR	Anton Khaplanov
Direct Spectroscopy	C-SPEC	Anton Khaplanov
Diffraction	HEIMDAL	Richard Hall-Wilton
Diffraction	DREAMS	Irina Stefanescu
Diffraction	BEER	Irina Stefanescu
Reflectometry	FREIA	Francesco Piscitelli
Reflectometry	ESTIA	Francesco Piscitelli

### Electronics

S. Kolya  
T. Brys

### Mech. Design & Integration

M. Anastasopoulos

### Coatings

C. Hoglund  
L. Robinson

G.L : Richard Hall-Wilton  
Dep. G.L : Scott Kolya  
Det. Proj. Dep : Judith  
Freita Ramos

# Detector Systems

Design the detectors and electronics as an integrated system

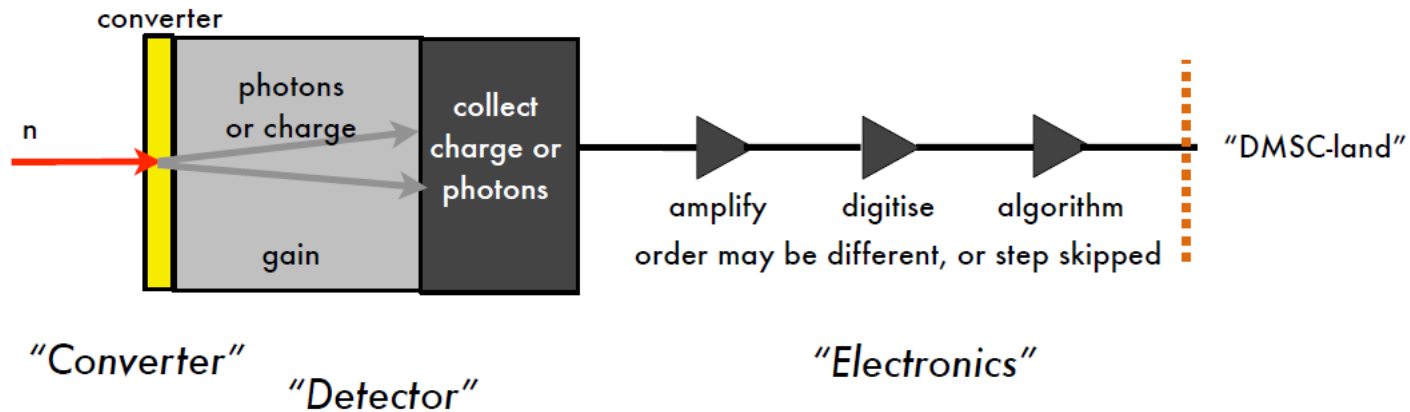

Very roughly equivalent to detector and DAE groups at other neutron sources

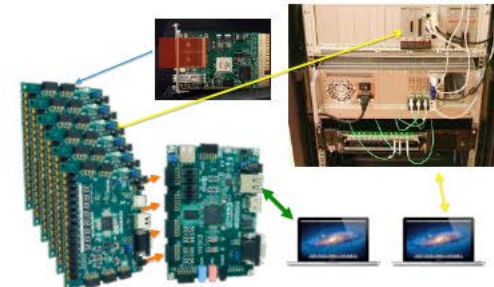
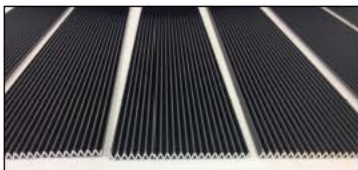

# Organisation and work break-down structure - Addressing the challenges

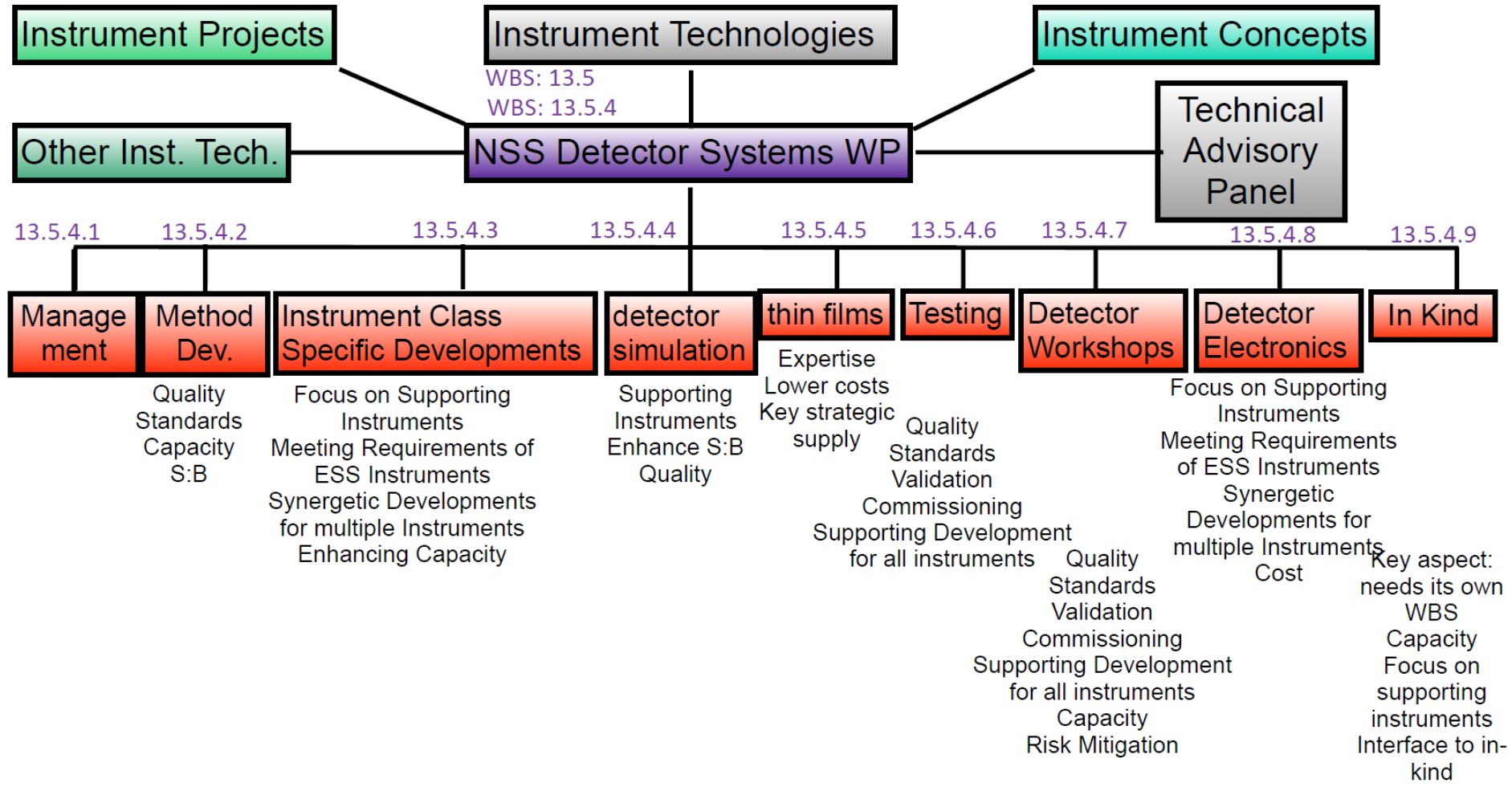

# DG between Instruments and In-kind

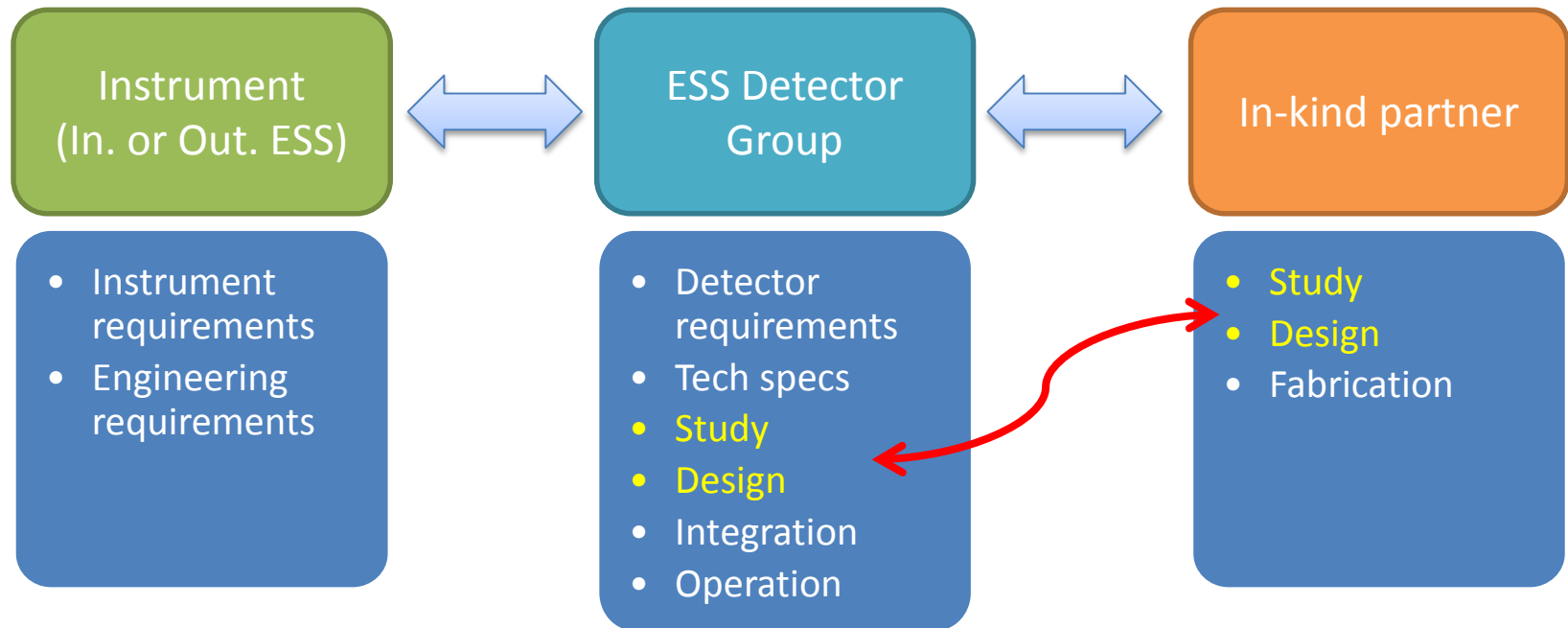

- **Study and Design will be done either at ESS DG or In-Kind**
- **Developments only done in case of specific needs based upon instr. req.**

# Schedule

## Example time-scale for Large Area Detector Tranche 1

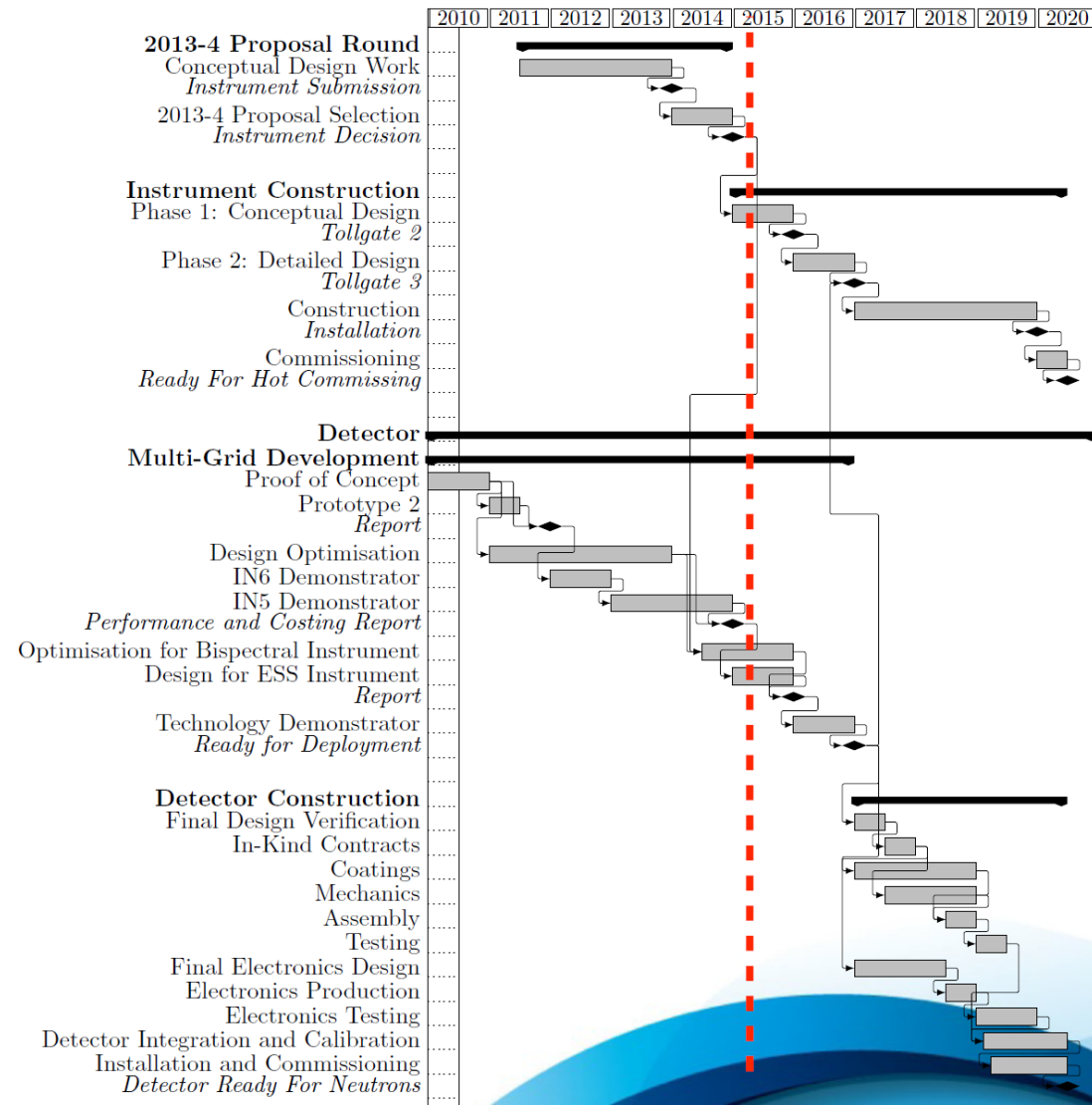

Progress so far

# LoKI detector project

## Key Tasks & Challenges 1/2:

- Selecting the appropriate geometry for the LoKI detector panels
  - Select the right detector technology meeting LoKI top level requirements
  - Decide module shape, size and geometry (arrangement) → size, shape and content of (vacuum) tank
  - Ultimately optimize budget?

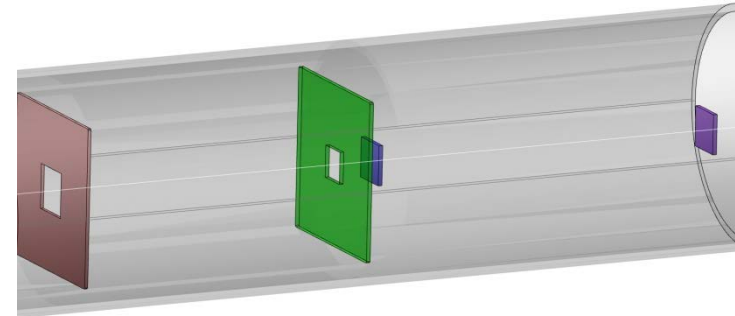

Window frame geometry

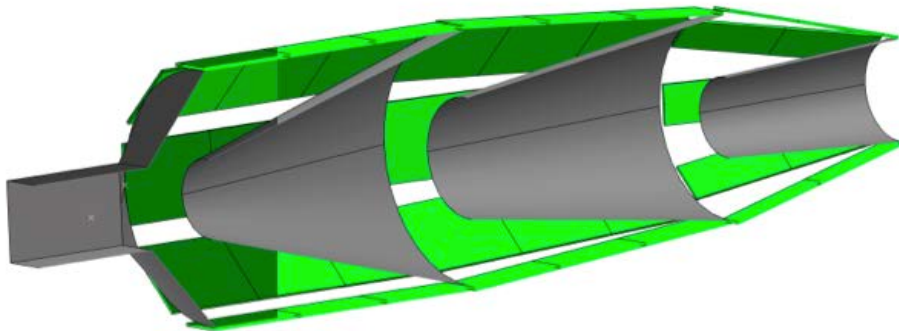

Tapered geometry

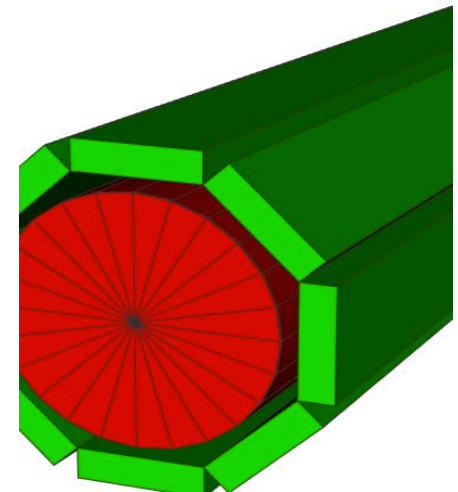

Barrel detector geometry

# LoKI detector project

## Key Tasks & Challenges 2/2:

- Detector simulation  $\leftrightarrow$  Engineering Design (loop)
  - Scientific reqs  $\leftrightarrow$  Engineering reqs
- Various steps to integration
  - DG interface - In-Kind (Milan)
    - CAD exchange
  - DG - Choppers (beam monitors)
  - DG - vacuum
- Interface to DMSC
- Interface to ICS

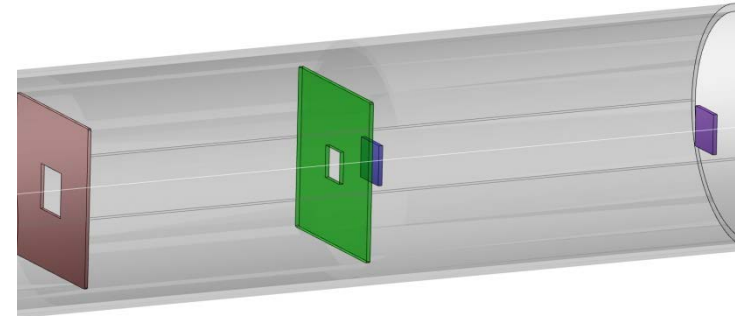

Window frame geometry

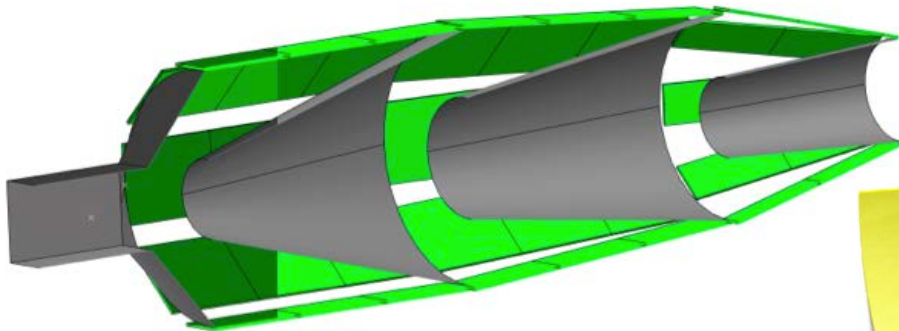

Tapered geometry

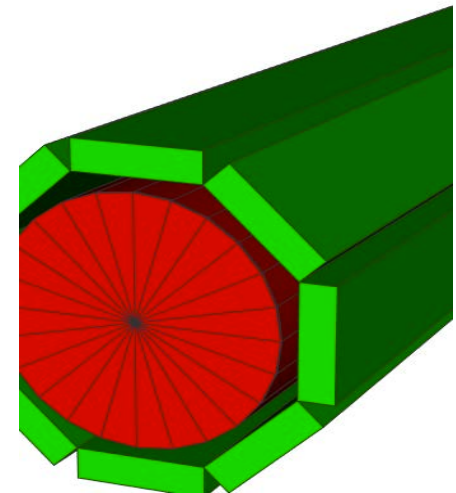

Barrel detector geometry

# Beam monitors

## Parallel processes

Integration

- In close collaboration with Choppers & Optics
- Standardization of interfaces
- Standard envelope
- Variants definition (universal solution for all instr.)
- Trade-off between size/beam interruption/accessibility

Selection

Fabrication

- Based on Instr. Req.
  - Selection
  - Adaptation
  - New design  
(if and where necessary)
- In-kind

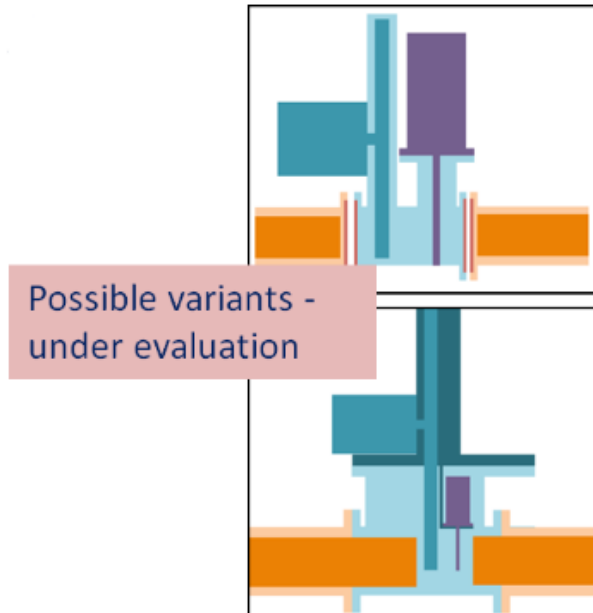
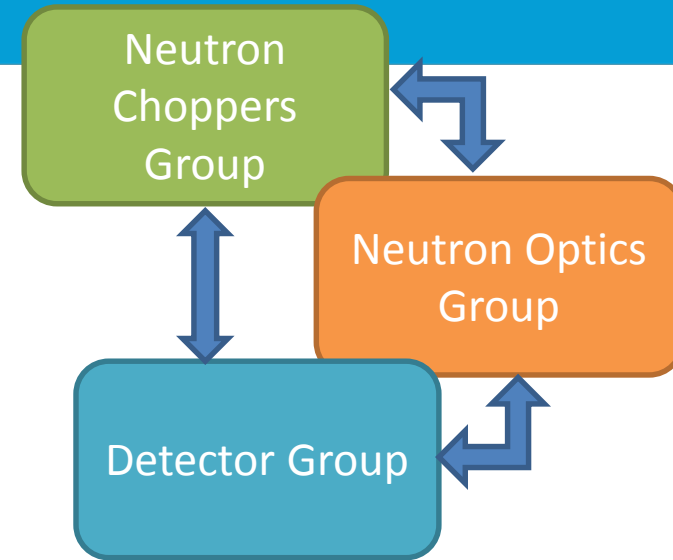

# Detector prototypes and demonstrators

## Example of a large Multi-Grid detector (Chopper spectrometers)



Coating

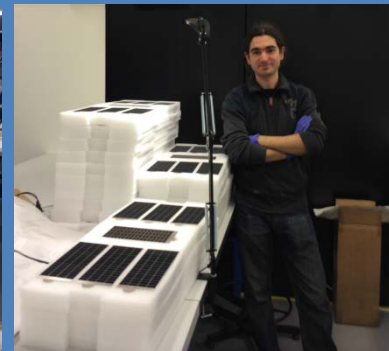

Grid Production

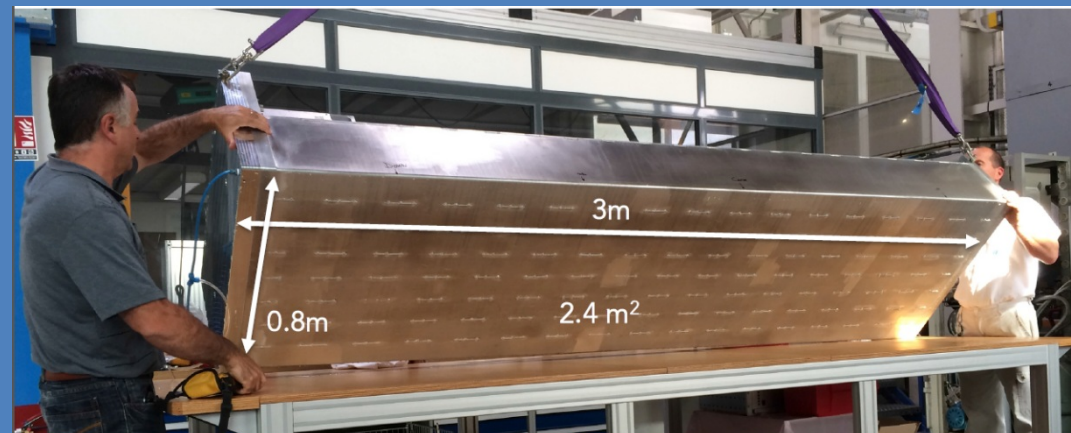
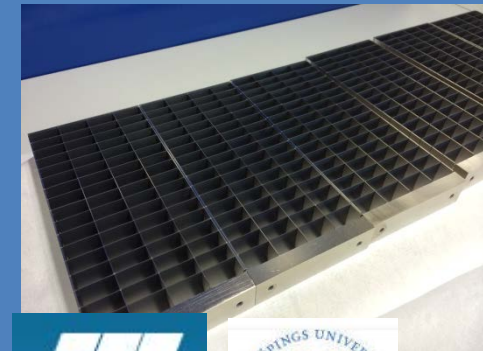

Wiring, Assembly, Testing

# Detector design & development

- **Modularized simplified design: does not require artisans for a fixed design and once tooling is developed**
- **1 column (3x0.1m) per week production rate once tooling is available**
- **Production assembly + trained supervision expertise**
- **Design work, tooling: ca. 18 months**
- **Production: ca. 4months**

• fundamentally multi-site  
 • may want a task to take place in >1 site  
 • perfectly fits in-kind

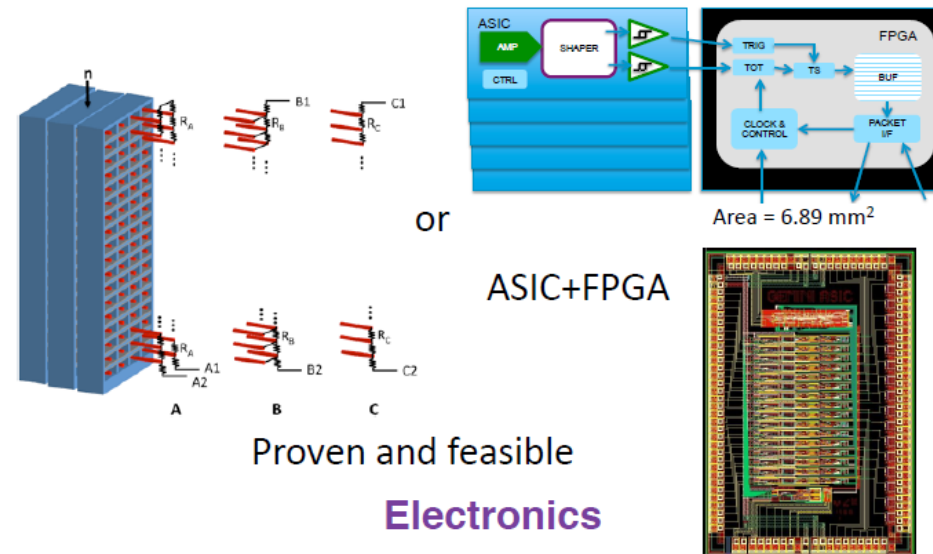
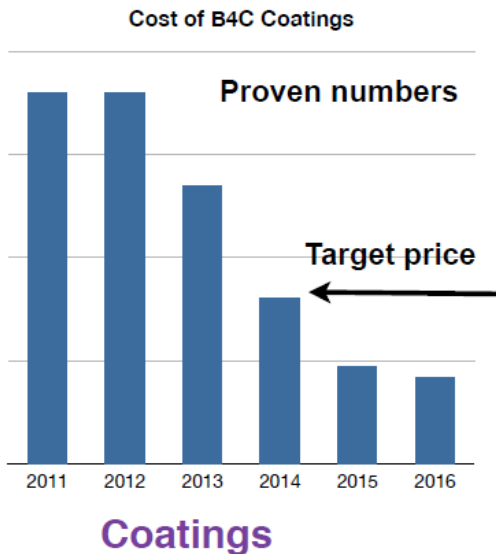



# Current Mech. Design & development

## ■ Macro-structure B10 based gas demonstrator

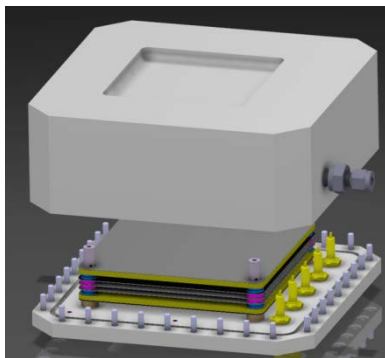

Final CAD model

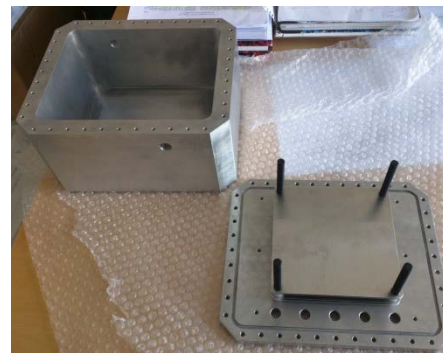

Parts fabricated and ready for assembly

*Test detector that will be used to study the quality of Boron-coatings, gas mixtures, anode wire planes, etc.*

Small-scale **OK**

*Address large-scale issues?*

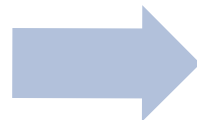

Large-scale

*Performance OK?*

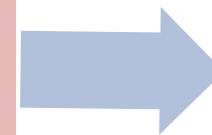

Ready for  
instrument

**Next:** realistic size demonstrator (20 cm x 40 cm) for testing the performance of macrostructured cathodes and resistive-wire readout electronics.

# Supporting facilities

# ESS Detector Group supporting facilities

## Mechanical Workshop (Shared facility)

- Fully equipped machine shop
- An area to build R&D detector components and assemblies
- Capacity to manufacture detectors mechanical components



CNC milling machine

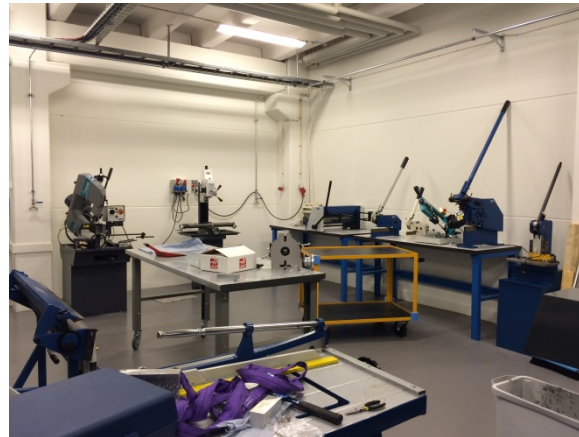

Various small machines



Assembling area

# ESS Detector Group supporting facilities

## Coatings workshop

An in-house production facility, that ESS Detector Group set up in Linköping for manufacturing  $^{10}\text{B}_4\text{C}$  coatings needed for the construction of  $^{10}\text{B}$  detectors.

Supply high quality neutron converters



Sputtering system  
Capacity:  $>1000\text{m}^2$  / year

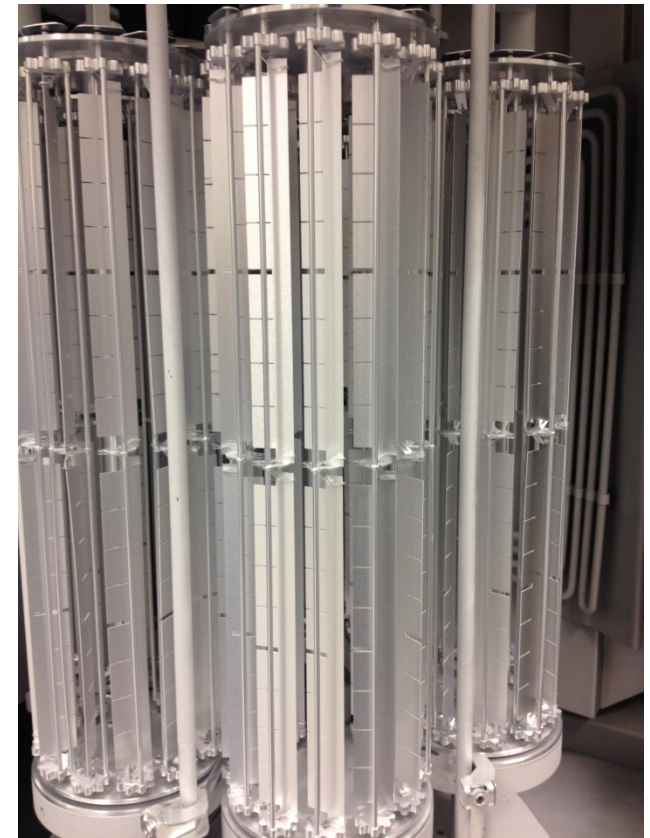

Blades prepared for  
deposition

# ESS Detector Group supporting facilities

## Detector Lab @MAXLAB, Lund



## Electronics Lab

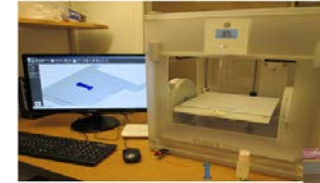

3D printer

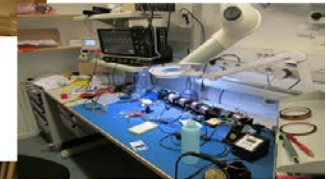

soldering room



electronics

## Future detector lab



## Source facility @ LU

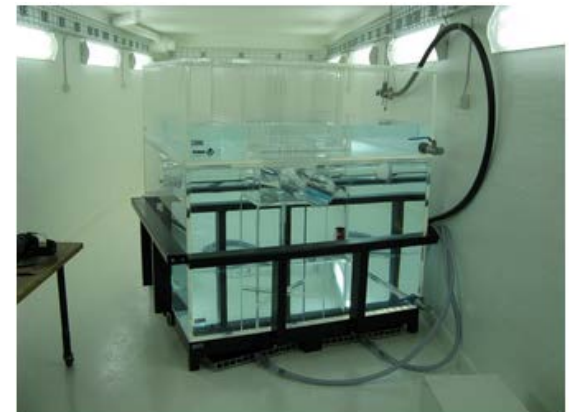

What's next

# Key activities for this year

- **Support phase 1 work for BEER, CSPEC, DREAMS, ESTIA, ODIN, SKADI**
- **Detailed design work for LOKI and NMX and associated demonstrator detectors**
- **ESS demonstrator detectors focused at large area and reflectometry applications**
  
- **Handbooks before the end of the year**
- **Snapshot of complete instrument strategies documents**
- **Finalise detector systems in-kind and successful launch of all in-kind work**
- **Complete core group**

# Handbooks, Standards, Strategies



- ❖ **Detector Handbook**
  - ❖ **Detector Standards Handbook**
  - ❖ **Readout Integration Handbook**
  - ❖ **Beam Monitors Handbook**
  - ❖ **Power Grounding and Electrical Shielding**
- ❖ **Additionally, each instrument class has a strategy document for detectors**

**Development under way - to be published by the end of 2015**

**THANK YOU FOR YOUR ATTENTION**

**We are here to support you**