



Chemistry and Life Science Support

Soft matter and Chemistry Sample Environment
SESC

PRESENTED BY ALICE CORANI

2023-09-19

Chemistry and Life Science Support - CLS

Structure of CLS with functional leads

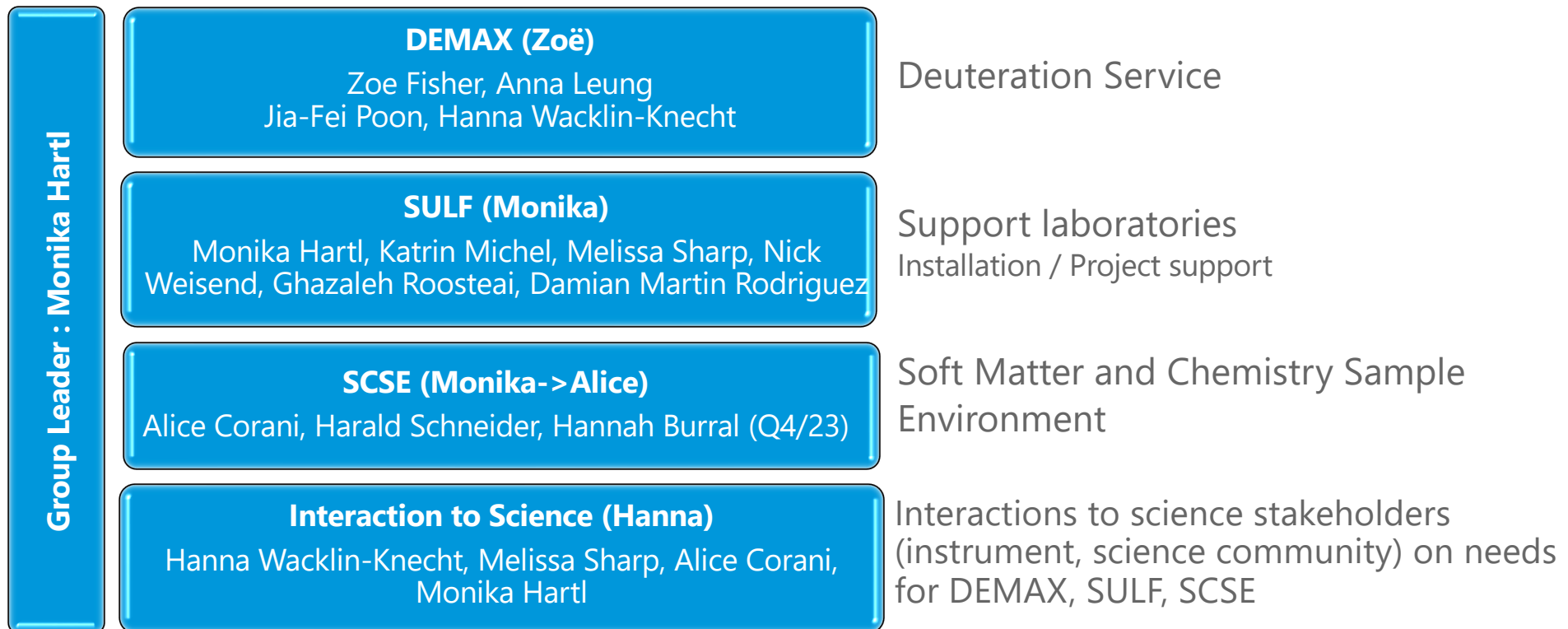

SCSE Team



Provide sample environment system and devices for soft matter and chemistry

• A. Corani:



- Sample environment related to chemistry, Electrochemistry and chemistry cells.

• H. Schneider:



- Sample environment for life science and soft matter R&D on ultrasonic levitator.

• H. Burrall :



- Sample environment mainly for Soft matter with H. Schneider

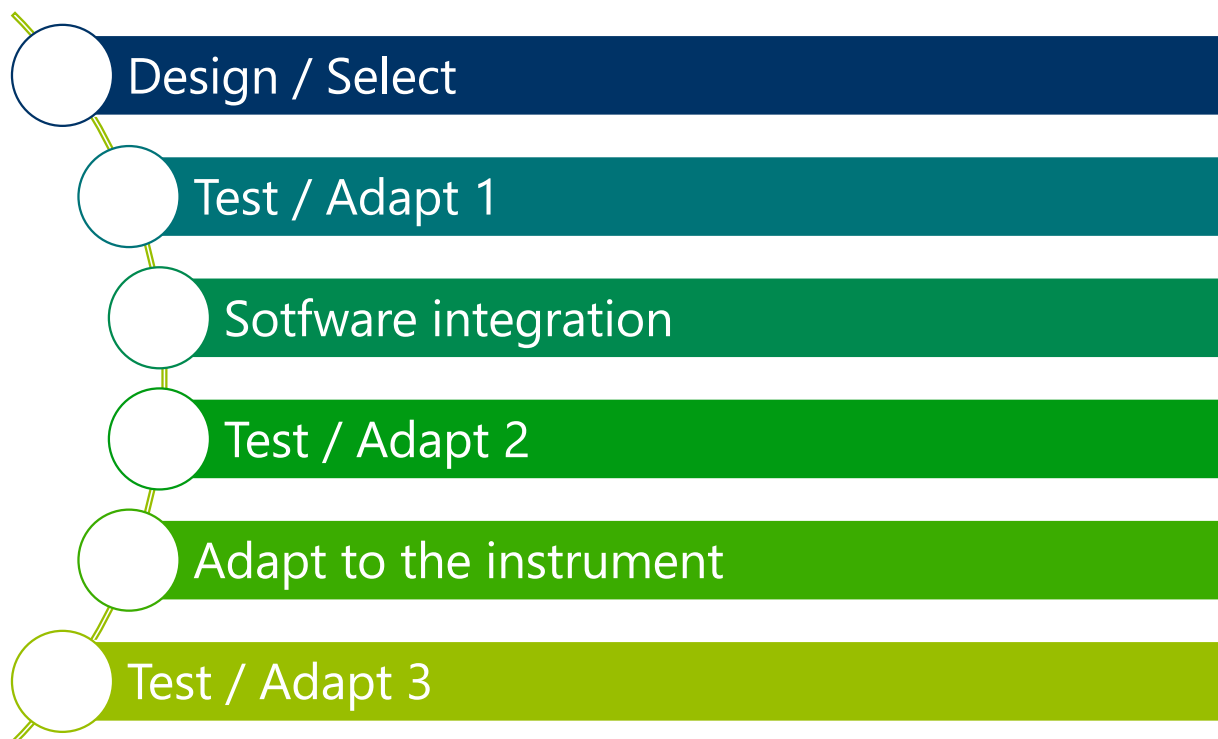

SCSE workshop

Currently being installed in D04 – Move in before end of the year



Current space:

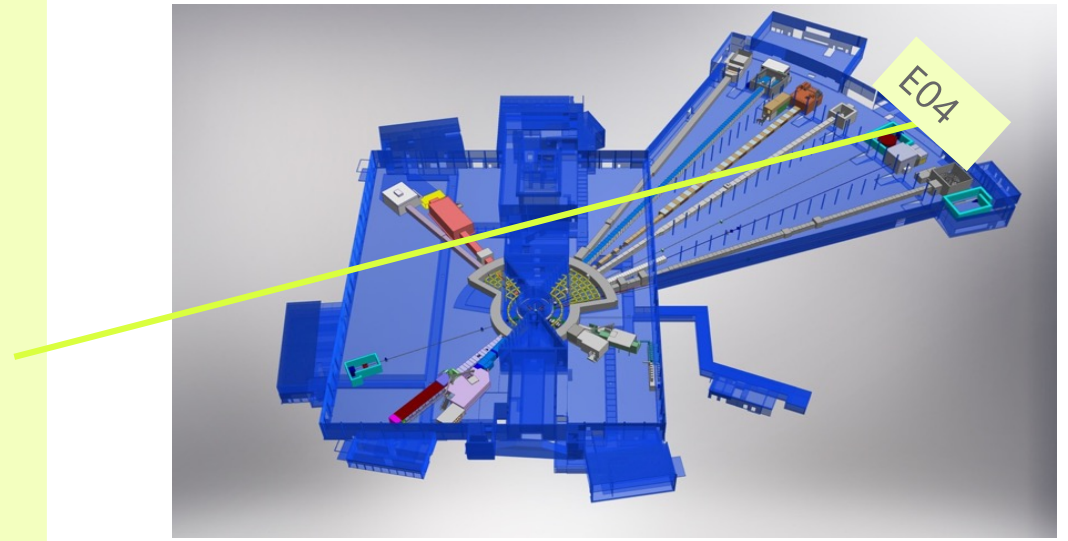

Working temporary in lab - E04

SCSE workshop

Currently being installed in D04 – Move in before end of the year

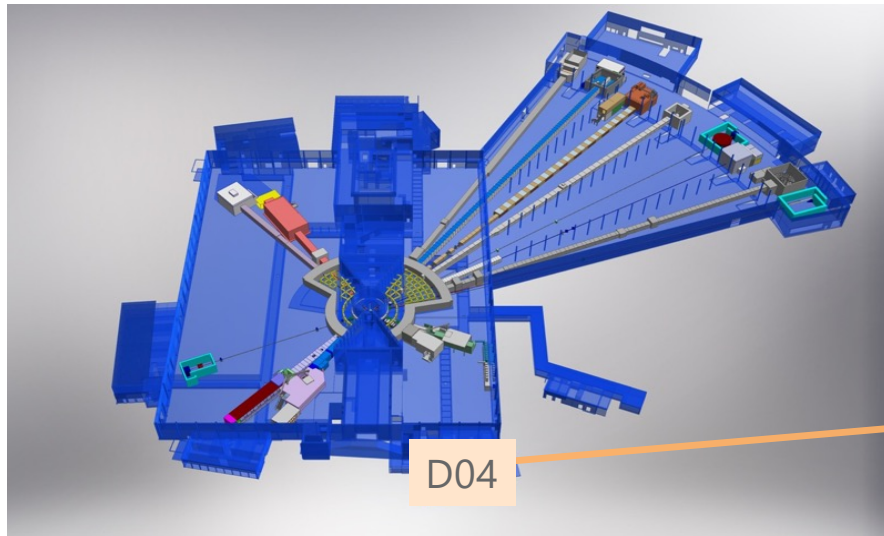

D04 Q3/23 – commissioning of workshop

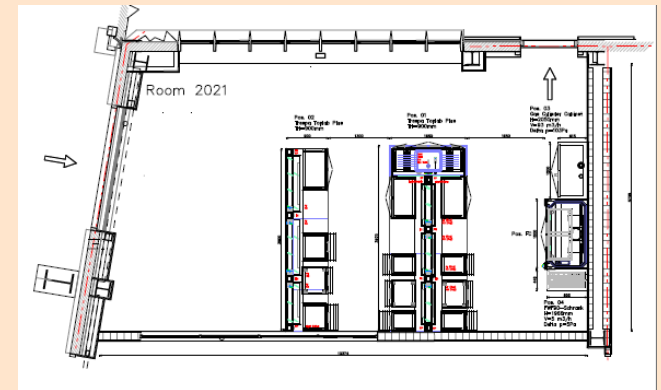

Soft matter and Chemistry Sample Environment



Provide sample environment systems and devices for:

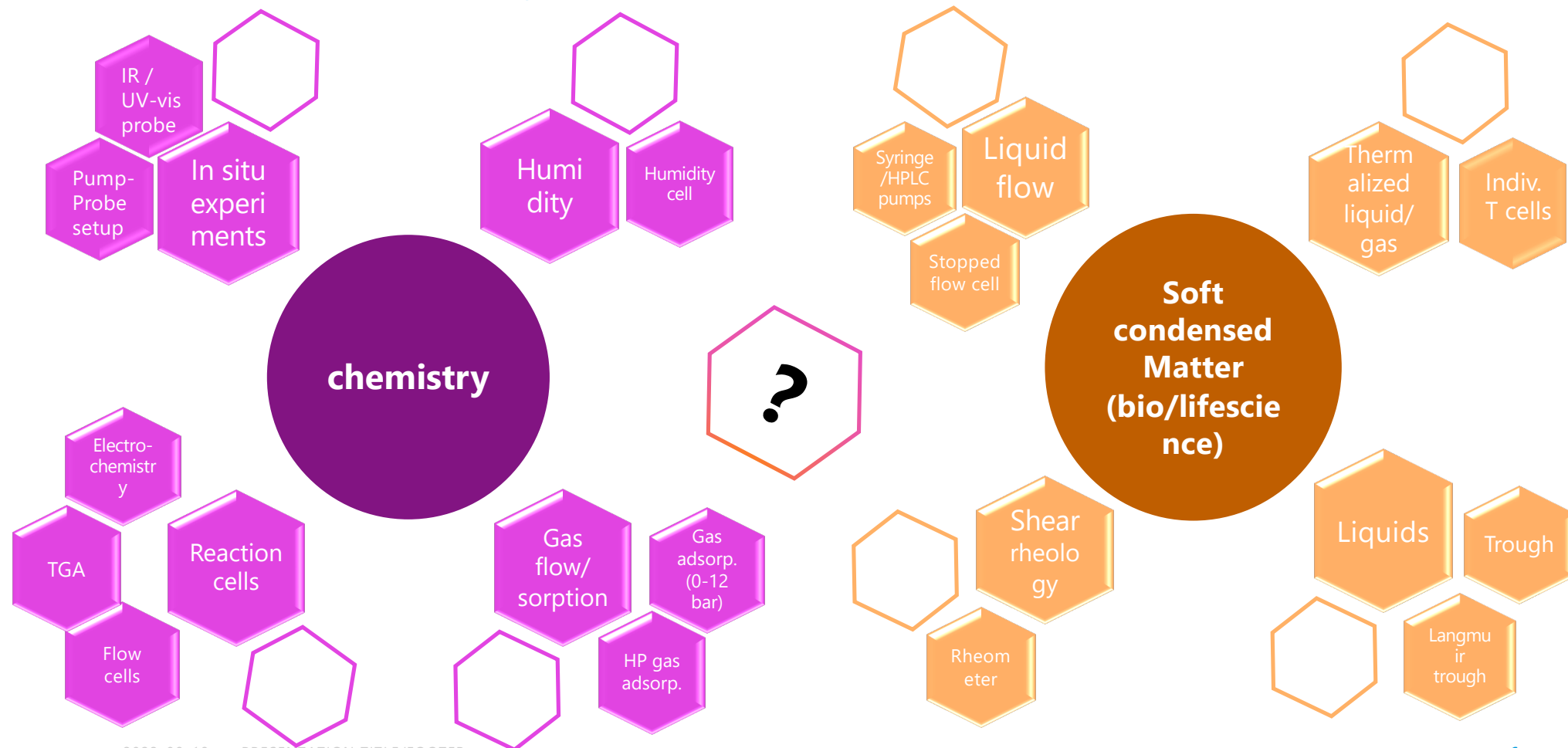

I2S – Interfaces to Science in CLS

Strategy and interfaces in Chemistry, Soft Matter & Life Science



Work with all stakeholders to:

Capture scientific requirements and efforts

Create a strategy/prioritisation for:

- First Science
- First proposal call
- Towards Steady state Ops

Liase with external stakeholders

Leverage synergies with other actors

Interact with instrument teams/ scientific community on support needs for science in the areas of DEMAX, SULF, SCSE;



Hanna



Melissa

Soft matter/life science



Alice



Monik

Chemiatry

I2S – Interfaces to Science in CLS

Strategy and interfaces in Chemistry, Soft Matter & Life Science

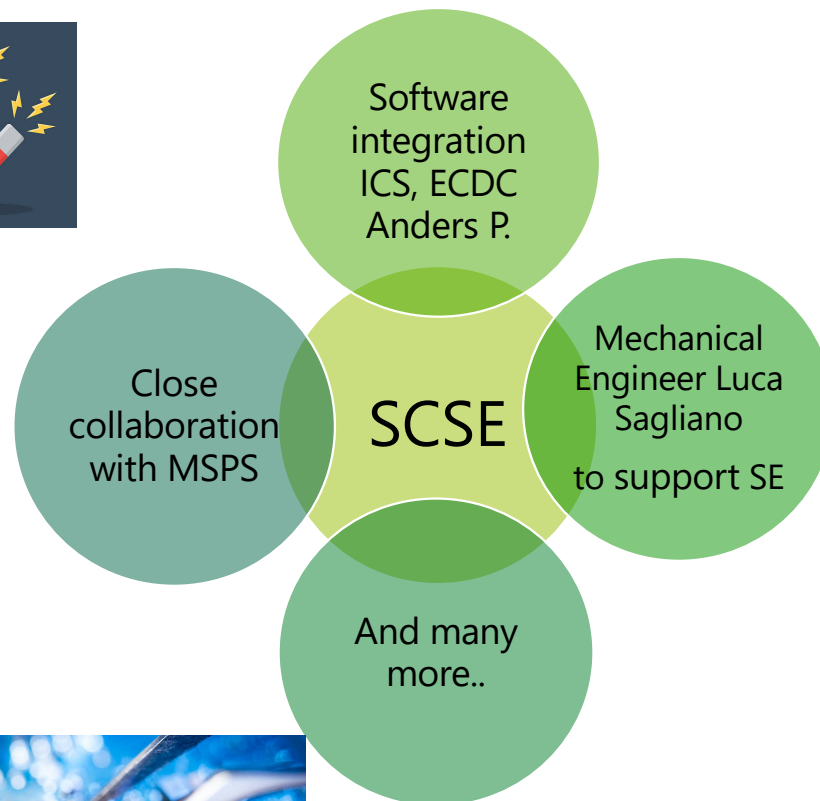
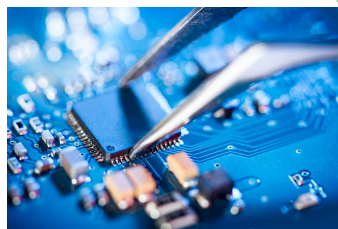
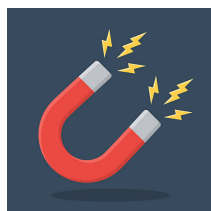

Budget & Personnel



Available budget is tight

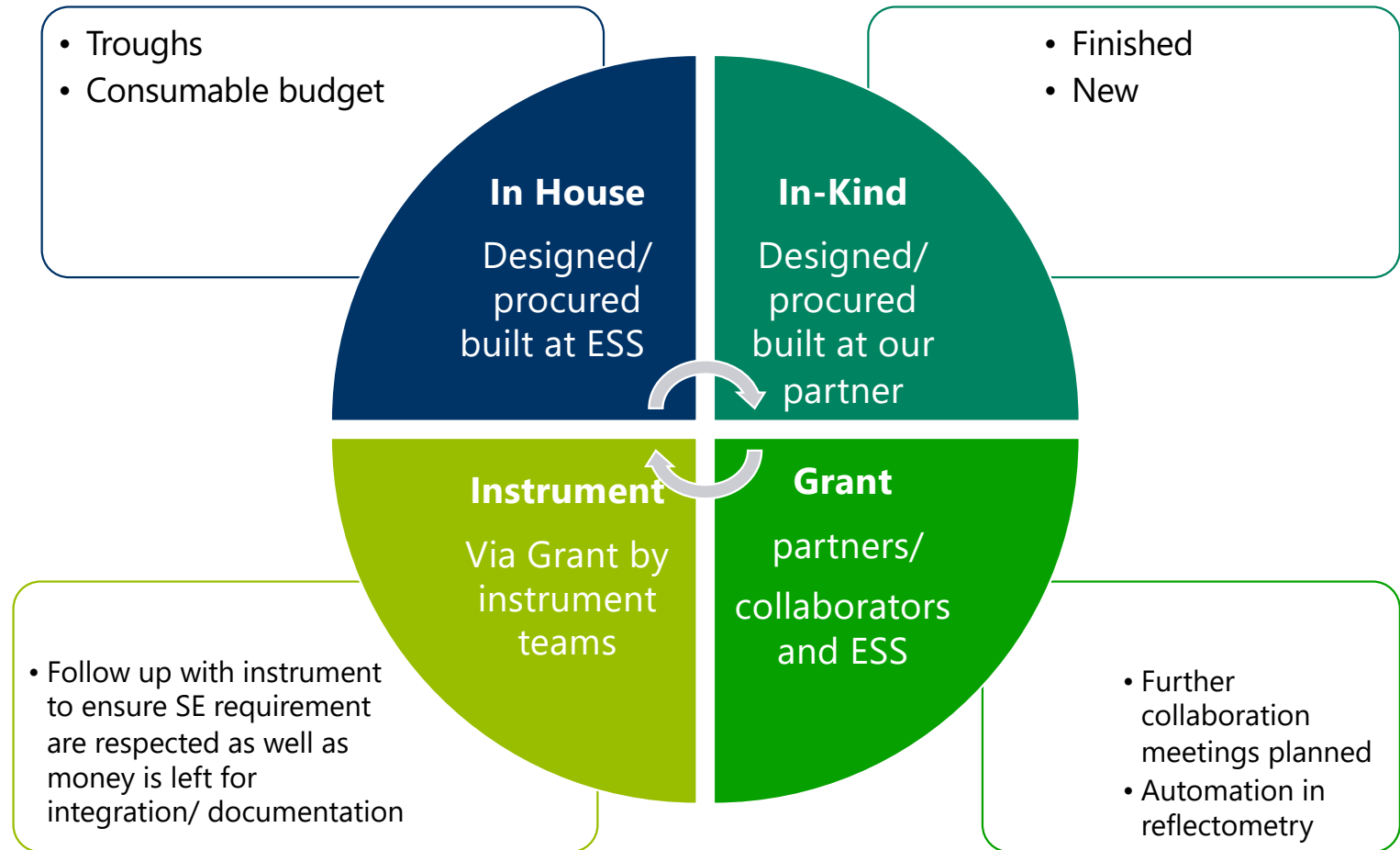

Reflectometry

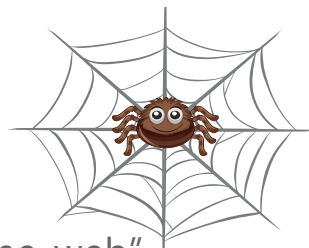

Friendly "spider-in-the-web"

www.freepik.com



- Solid-liquid cells for each instrument
- Multiwell-solid-liquid cells (ESTIA)
- HPLCs + syringe pumps/switches
- Small volume/cooled + multi-well troughs
- Humidity cell, WLS, GISANS (Flexiprobe)
- Julabos
- Temperature controllers
- Antivibration table
- Laser interferometer (Keyence)
- Liquid-liquid cells
- Electrochemical cells + potentiostat
- In-situ ellipsometry/FTIR cells + mount (design)
- Ellipsometer/FTIR spectrometer
- Furnace
- overflowing cylinder
- Automation/autosamplers



Nils Brommer 1845



La Hestia Giustiniani 460 bc

Solid/Liquid Cell Holder

Sample Cell Description

- Modularity allows cell components to be used in a variety of combinations
 - Vertical & horizontal geometry
 - 1 or 2 sample compartments
- Polycarbonate and PEEK back pieces designed to optimize fluid flow
- Thermalized control with Julabo water circulators and monitored with Pt100 sensor
- ESTIA: 5 cm x 5 cm x 1.5 cm
- FREIA: 8 cm x 5 cm x 1.5 cm
- Sample volume: < 0.6 mL

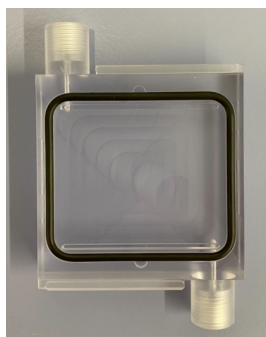
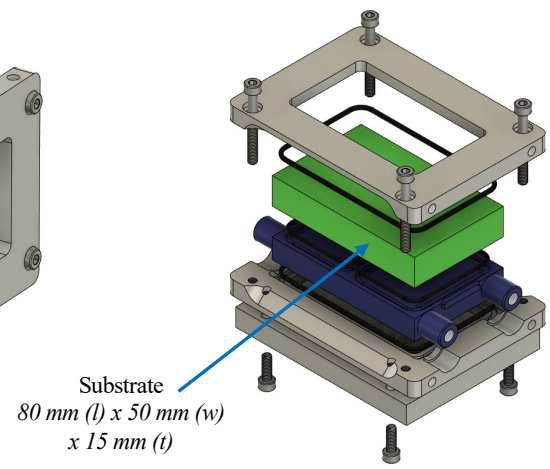
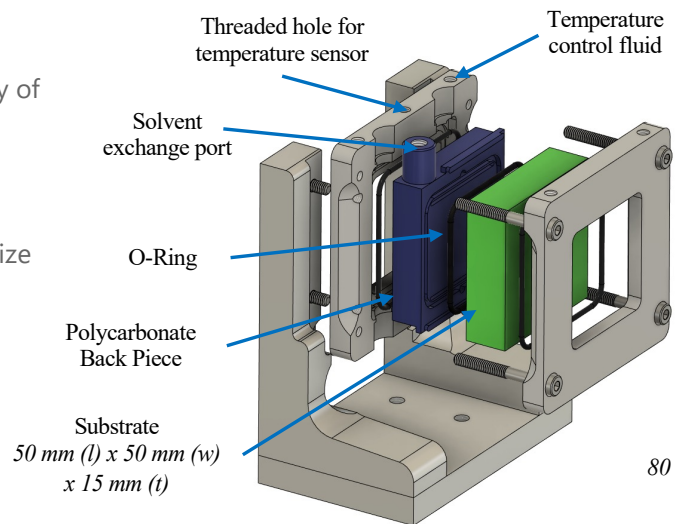

5 cm x 5 cm
Polycarbonate Back Piece
1 Compartment

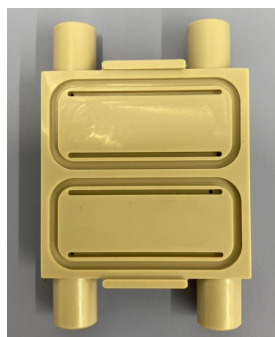

5 cm x 5 cm
PEEK Back Piece
2 Compartments

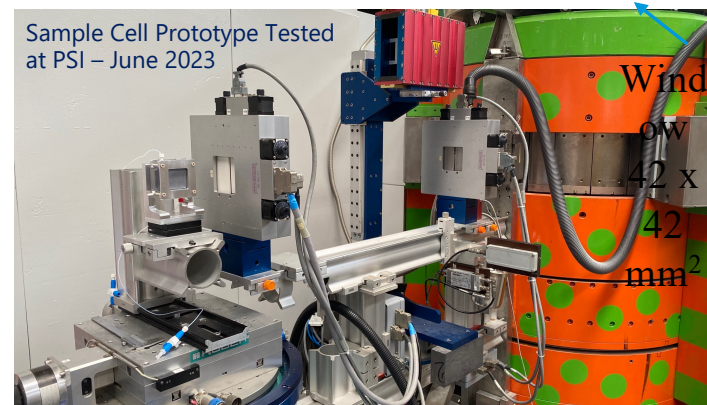
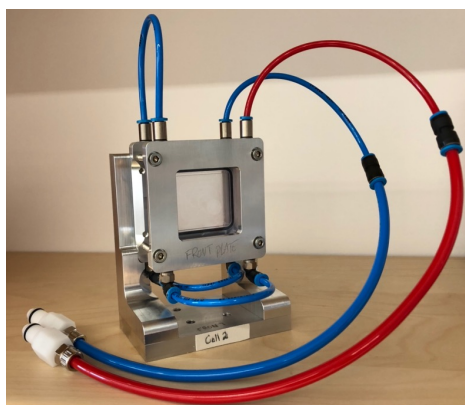

Solid/Liquid Cell Sample Changer

Passed Sub-TG3/CDR Design Review

- 7 sample cells
- Fully automated sample filling from either direction (top → bottom / bottom → top)
- Compatible with standard SE Kipp L2 interface

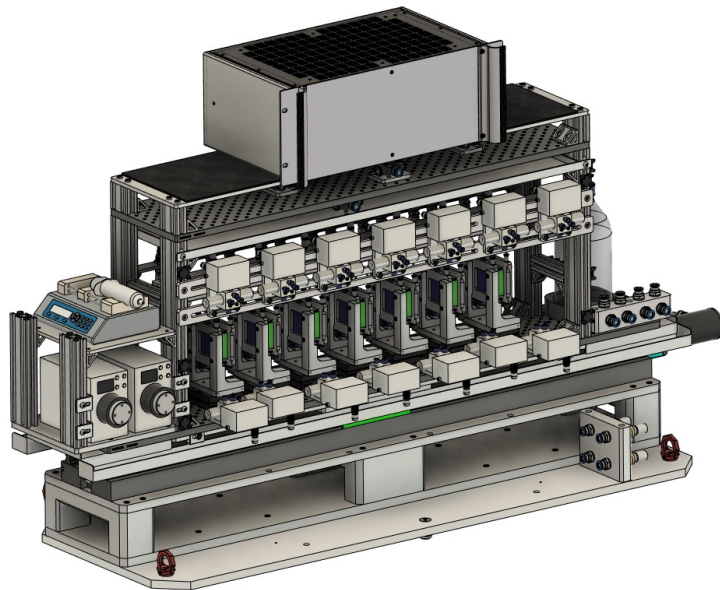

Currently in Production

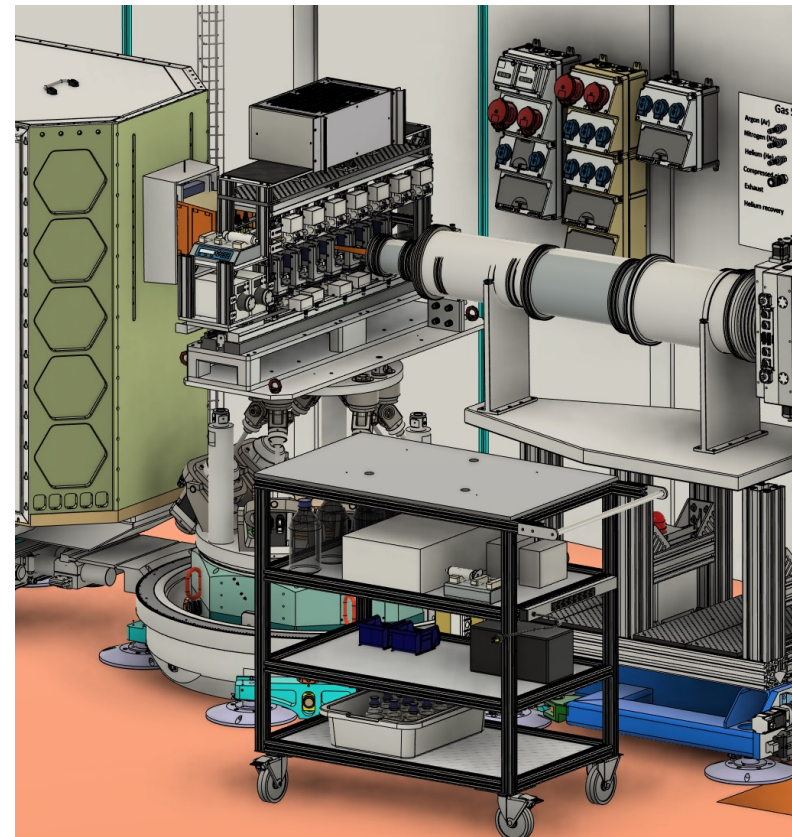

UPPSALA
UNIVERSITET



A combined IR and ellipsometry setup

As part of project SREss3 from Tillväxtverket (Thomas Ederth, Linköping University)



Buils on an existing Röntgen-Ångström Cluster (RÅC) project

Design work is essentially complete

Looking to deliver this as an in-kind contribution to ESS

Test beamtime was unsuccessful due to extended ISIS downtime – rescheduled probably in Nov/Dec

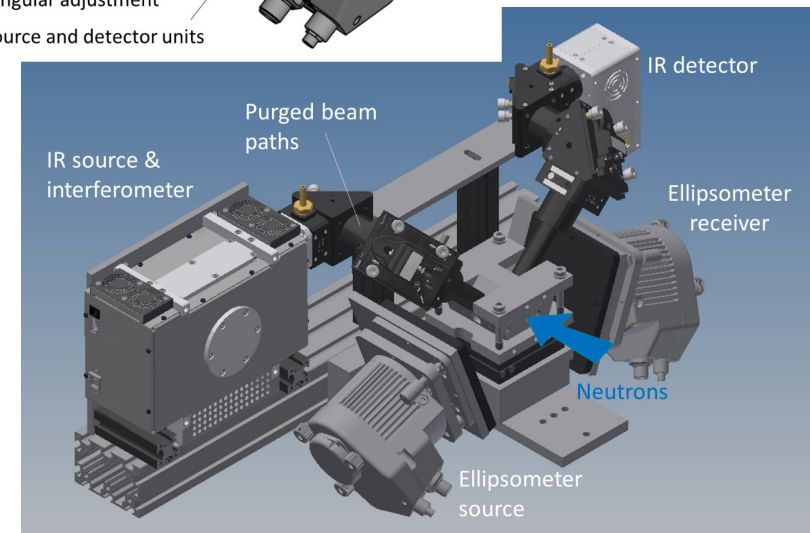
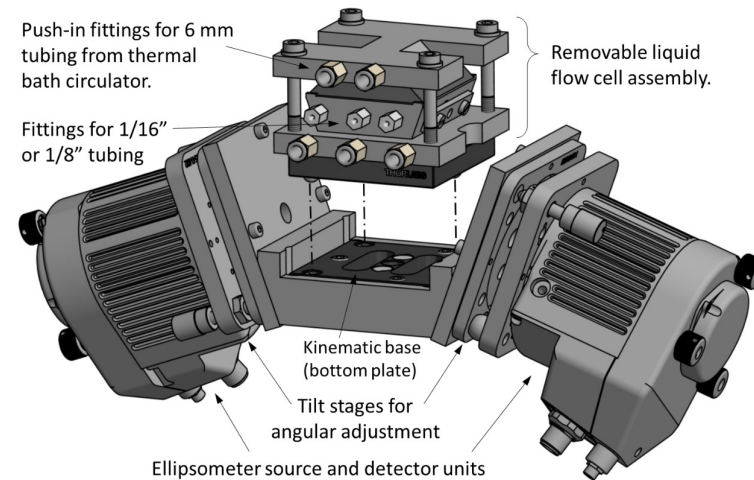

SCSE – STATUS OVERVIEW



	Sample Environment System (SES)	Design/select	Test/adapt I	Software integration	Test/Adapt II	Adapt on instrument
Reflect.	Troughs (various)	Starting				
Reflect.	Solid liquid cell	Done				
POOL	Syringe pumps	Done		Done		Documentation
POOL	HPLC pumps	Done		Done		Documentation
POOL	Julabos	Done		Done		Documentation
POOL	Potentiostat	Done		1st level		
LOKI	Stopped-flow cell	Done		On going		
Spec./ Diff.	Isorb gas sorption High pressure	Done				
Spectro	Laser pump probe	Done	At ESS Q3 2023			
POOL	Humidity chamber	Done	At ESS Q3 2023			
POOL	Humidity Generator	Done		On going		
POOL	2 EC/Battery cells	Done	At ESS Q3 2023			

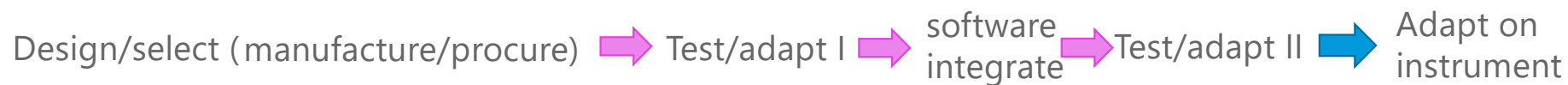

SCSE – STATUS OVERVIEW



	Sample Environment System (SES)	Design/select	Test/adapt I	Software integration	Test/Adapt II	Adapt on instrument
LOKI	Thermoslistated sample changer for quartz cuvettes (part of SANS Mag)	Done				
LOKI	Cell tumblers/rotating sample holders (Part of SANS mag)	Done				
	DREAM EC/Battery cell	Ongoing				
ODIN	EC/Battery cell					
	DREAM TGA					
LOKI	Flow cell (including HPLC pumps, Part of the NURF for LOKI)	Done		Done		
LOKI	In situ spectroscopic measurements for the flow cell (NURF for LOKI)	Done				
SANS	Flexiprobe	Done				
SANS	Rheometer	Done		On going		
SANS	Huginn cuvette rack	Done		Done		

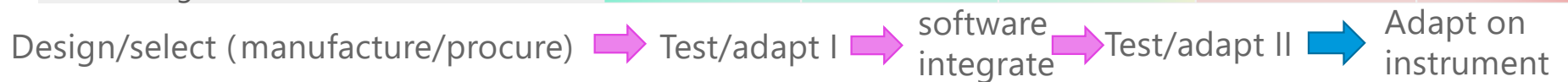

Future plan

Priority for reflectometry

Solid liquid cells

- Assemble / test / adapt
- Follow integration processes



Troughs Langmuir and absorption

- Develop a strategy for procurement of troughs
- Collaboration with ISIS/ILL
- Adaptation of commercial troughs

Input on other interest ?

- Solid film deposition
- ...



Follow up on the possible grant



Vetstreet

Train the operator

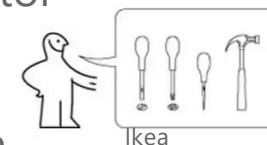

Documentation



Thank you

