

NMX Project Status Overview

NMX STAP

2023-10-16

Esko Oksanen

Lead Scientist NMX

Outline – project status

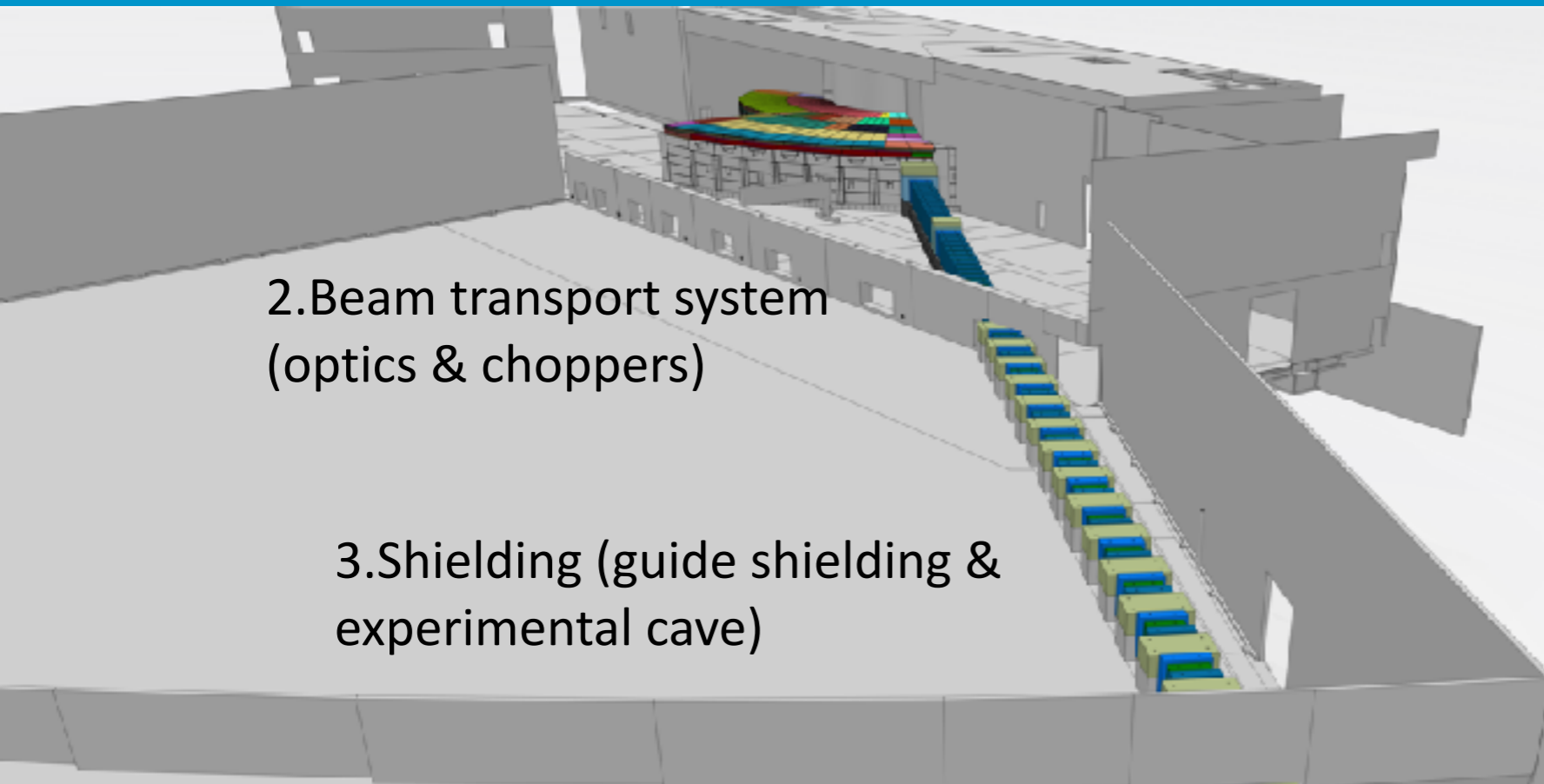

2. Beam transport system
(optics & choppers)

3. Shielding (guide shielding &
experimental cave)

1. Personnel & project
changes

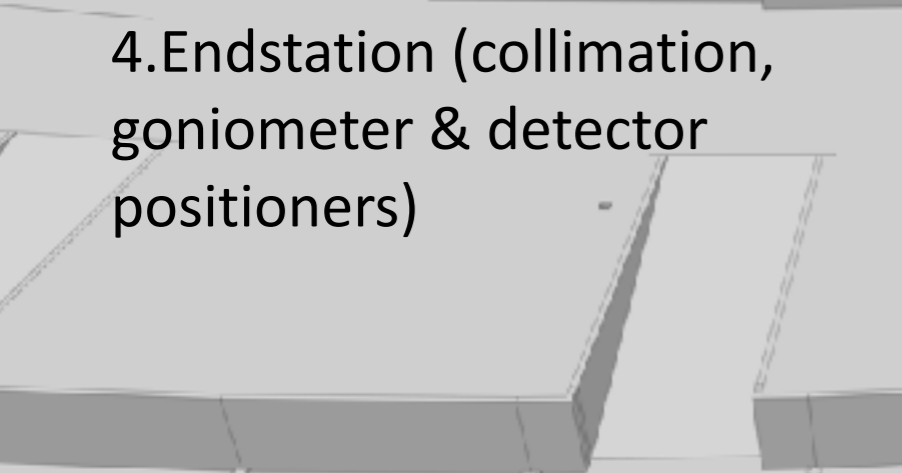

4. Endstation (collimation,
goniometer & detector
positioners)

6. Utilities

7. Scope for first
neutrons

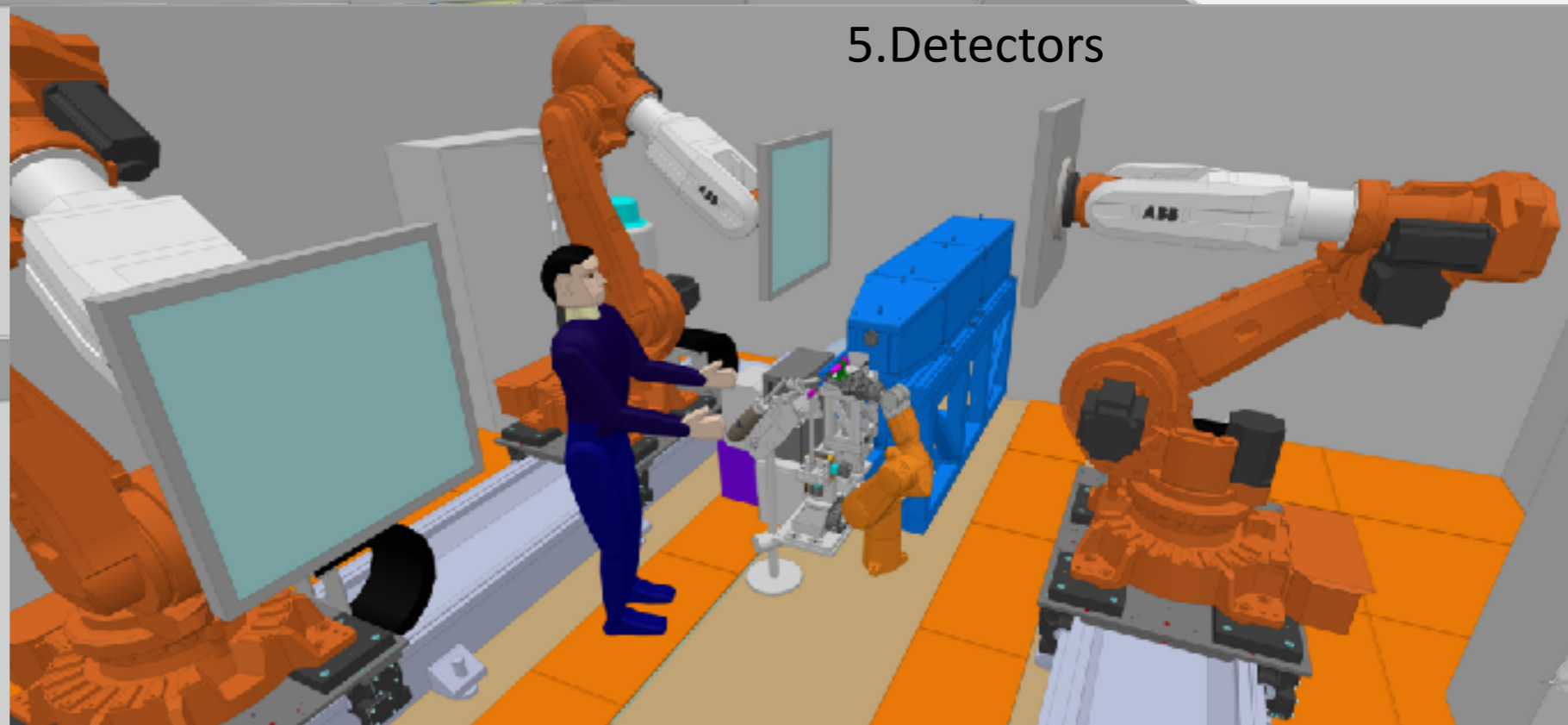

5. Detectors

Personnel & Project Changes



- NMX has been moved to the Tranche 1 of instruments – ready at first neutrons
- Giuseppe Aprigliano has become the leader for the NSS Technical Projects Group
- Rosa Camilleri Lledó will take over as Lead Instrument Engineer, but will be on parental leave from Jan 2024
- Daniel Lundström will support Rosa until that and cover for the Instrument Engineer role under Rosa's parental leave

Beam transport system – neutron optics



Installed Jun 2023

Installed June 2022

In-kind from Hungary, installation ongoing, finish Dec 2023

In-kind from Hungary, installed Dec 2022

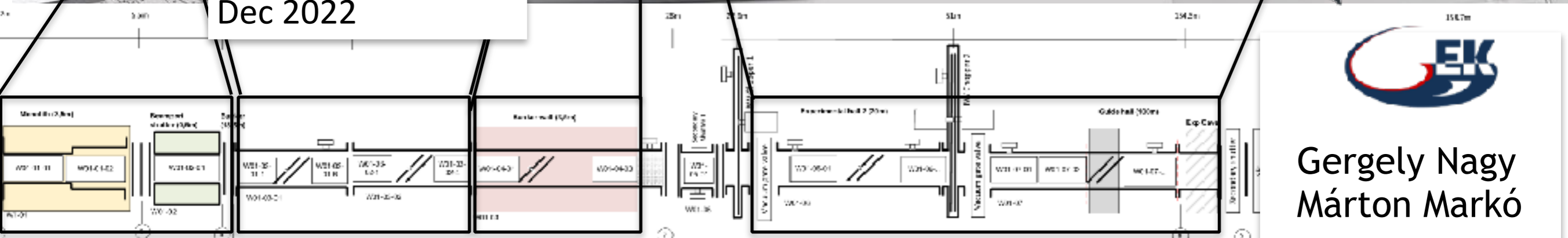

In-monolith optics

Curved guide in bunker

Bunker wall insert

Straight guide outside bunker



Gergely Nagy
Márton Markó

Shielding

- Experimental cave completed and accepted
- Common shielding project delivers guide shielding – neutronics simulations were performed in Hungary
- Guide shielding manufactured and mostly delivered, installation finish after guide & chopper cable installation (Feb 2024)



Szabina Török
Gabor Nafradi
Tamás Bozsó

Endstation – Collimation system



- Slits delivered and tested
- Collimation box delivered
- Pinhole exchanger prototype built and integrated with the ARINAX system
- Installation to be planned with robot installation

Endstation – Robotics



Delivered by ARINAX, CDR passed
Oct 2023 expected delivery Aug
2024

20 μm cylinder of confusion ensured with an
extra axis (Heidenhain ceramic bearing)

Detectors

- Scope transferred to detector group, delivery expected Q2-3 2024
- Assembly of detector units started May 2023
- Protective box waiting for manufacturing drawings
- Full ESS readout chain tested for two quadrants (50x25 cm) with neutrons in Budapest
- Analysis of the results of the Budapest test ongoing

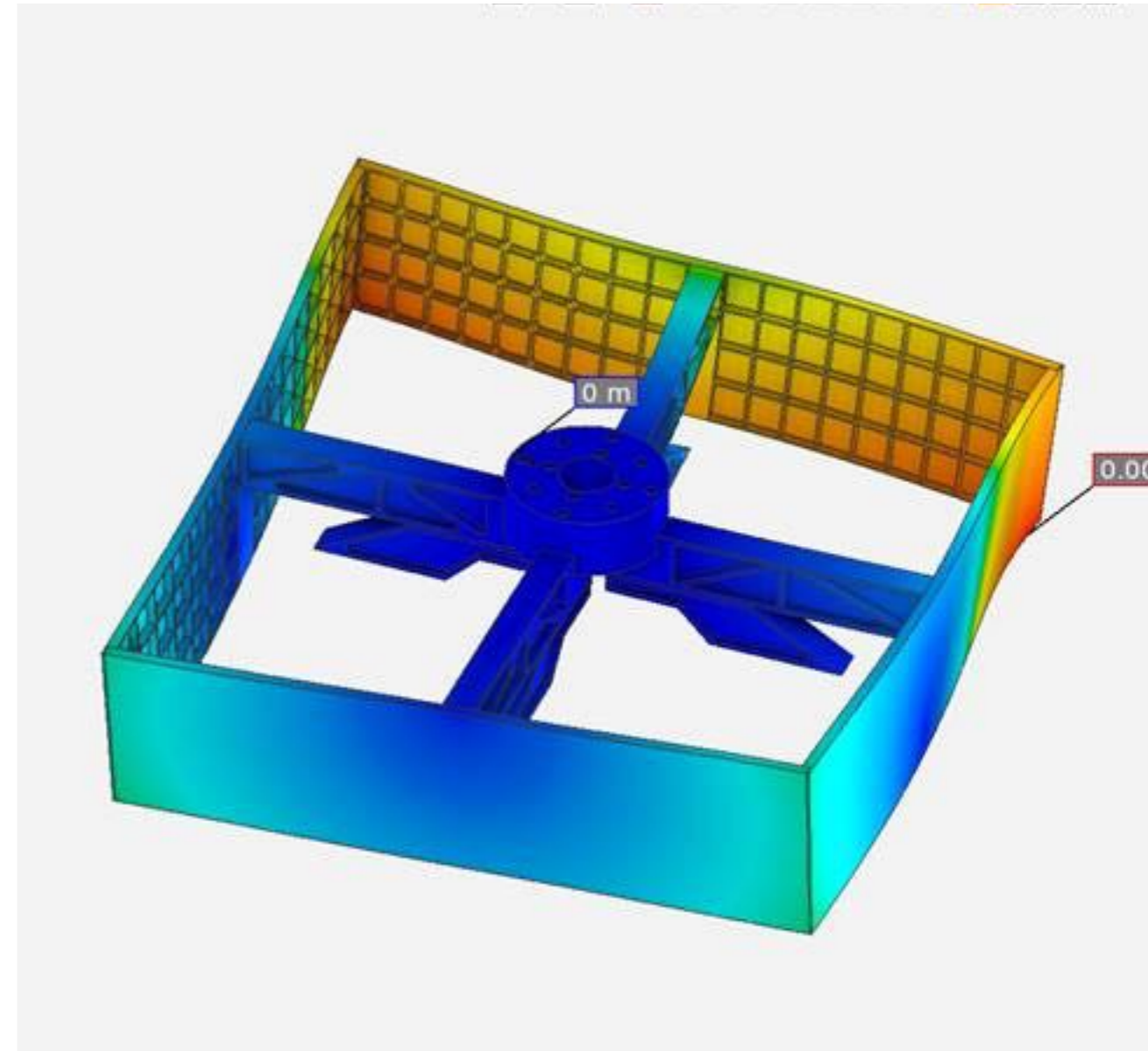

Jerome Samarati
Dorothea Pfeiffer

Detector readout architecture

Detector

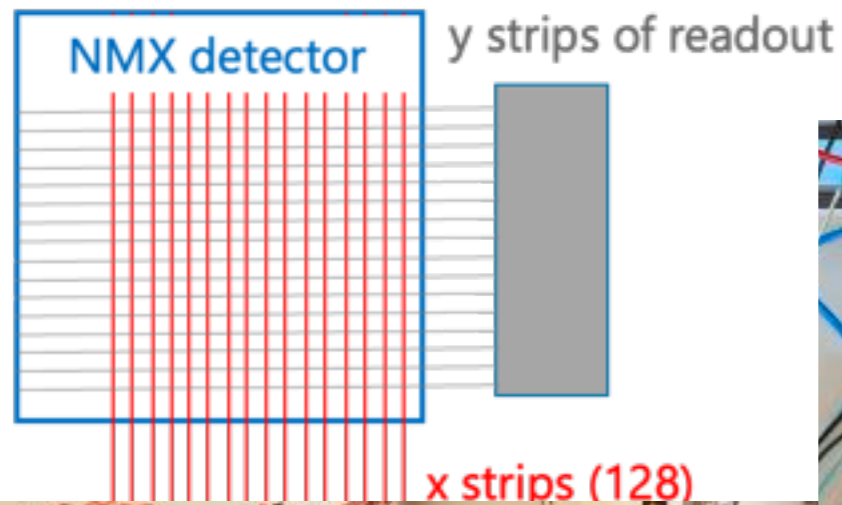

02/06/2022

Rack or separate crate

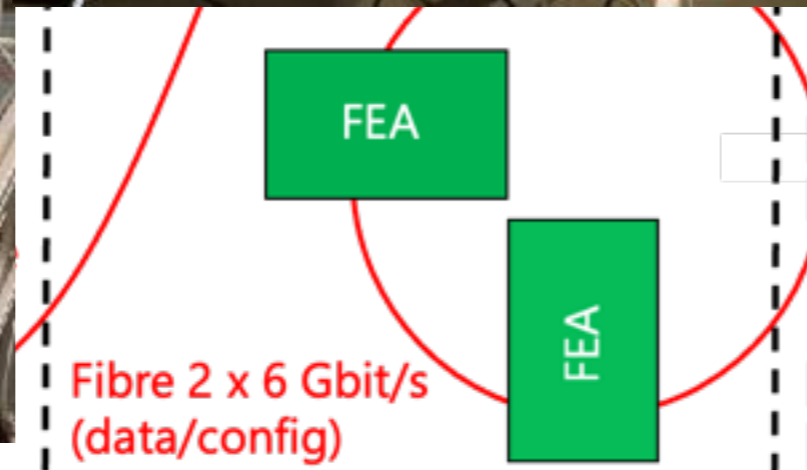

Rack

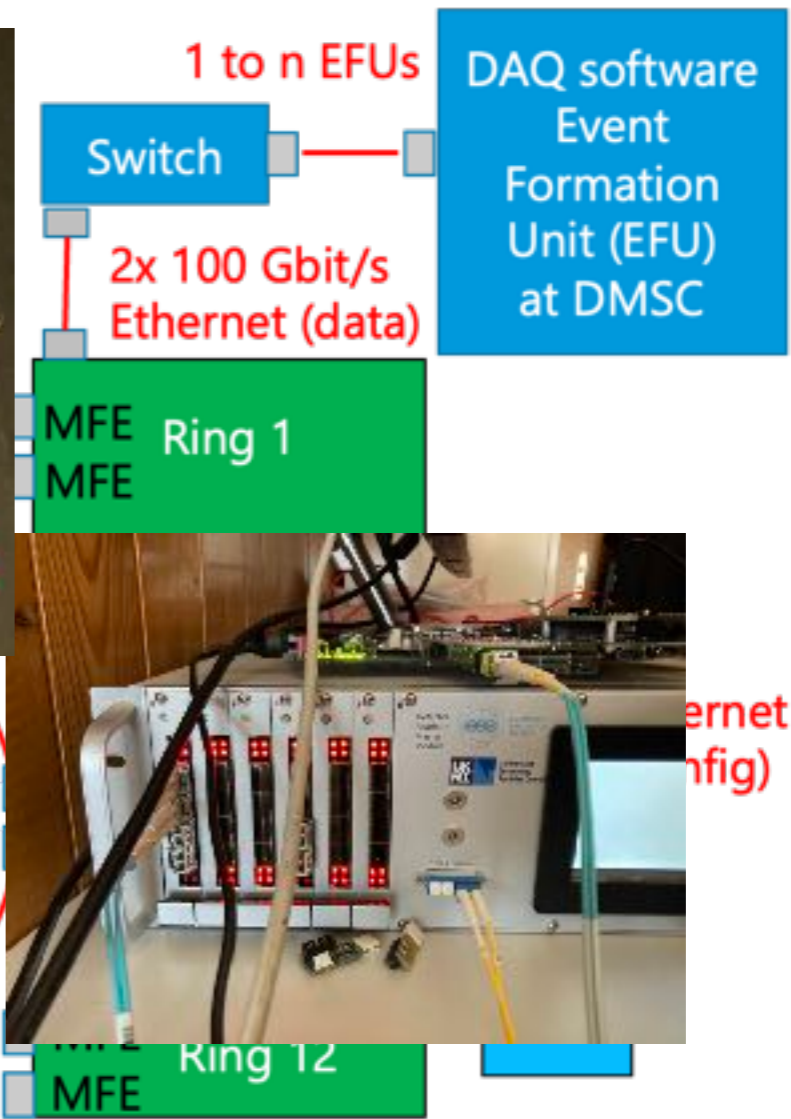

- NMX has joined the ESS Common Electrical & Common Utilities Projects
- Detailed design is ongoing
- Installation foreseen early-mid 2024

Scope for first neutrons



- ESS Beam On Target (BOT) milestone is currently in May 2025
- The safety reviews required for that include Tranche 1 instruments
- Due to the review schedule instrument cold commissioning should be finished ~6 months prior to BOT – a challenge for NMX

Scope for first neutrons – NMX



- Uncertain whether detector electronics (assister boards) will be ready
- Full NMX scope not needed for initial hot commissioning
- Solution: reduce scope at BOT to demonstrator detector on a simple table

Questions?

esko.oksanen@ess.eu