

Neutronics Calculations for the SNS Second Target Station Target and Moderator Final Design

Lukas Zavorka, Kristel Ghooos, Igor Remec, and Jim Janney

Oak Ridge National Laboratory, Oak Ridge, TN, USA

ICANS XXV

April 13-17, 2026, Malmö

Spallation neutron sources

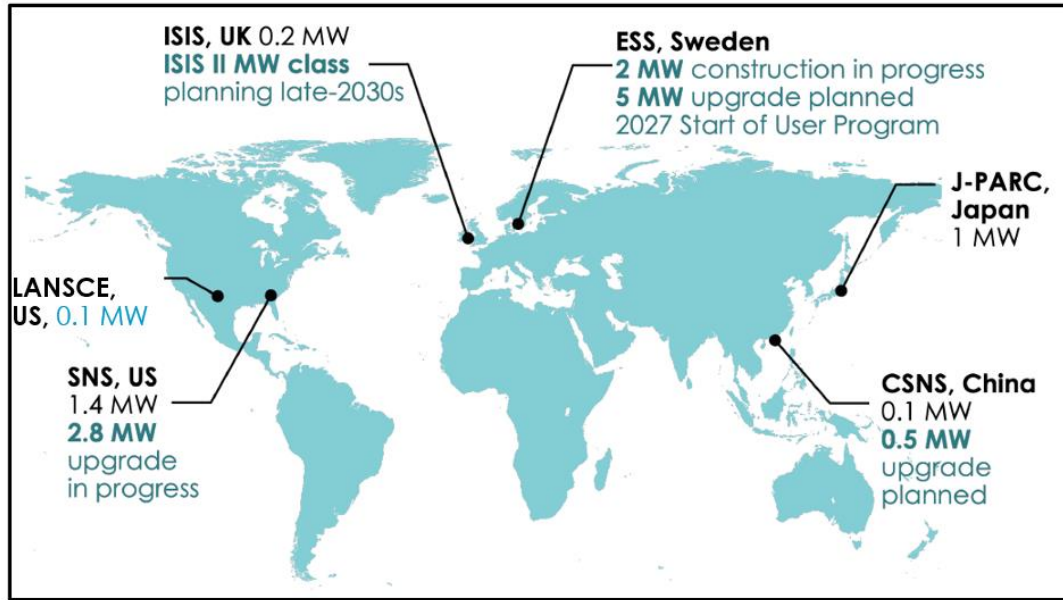

The STS objective is to become the highest peak-brightness source of cold neutrons

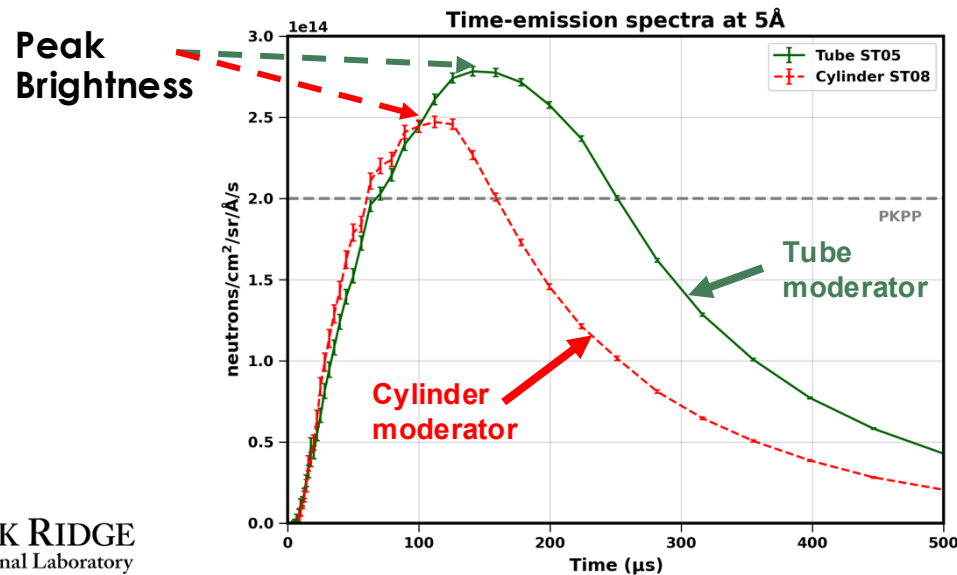
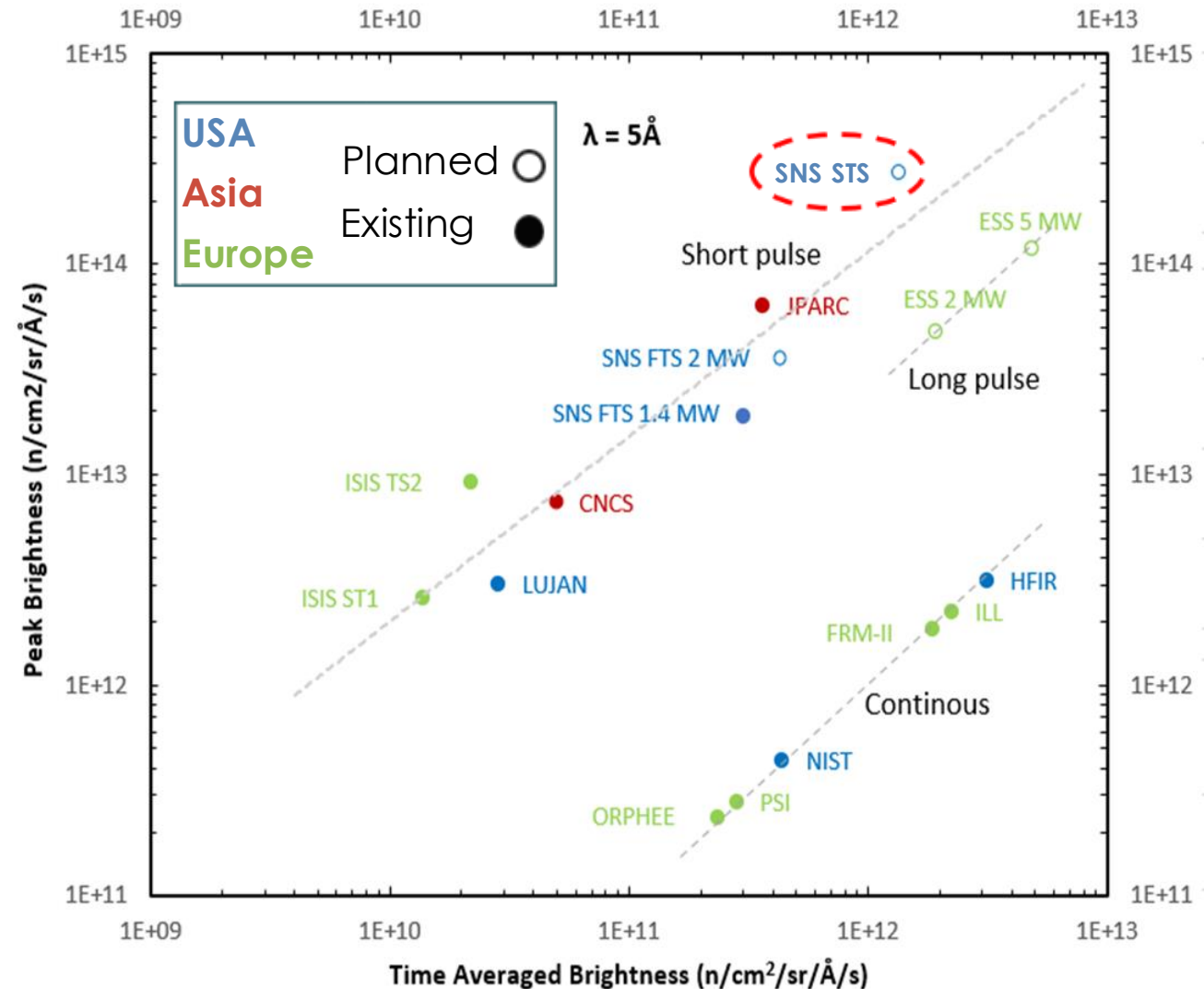

FTS and STS



FTS (upgraded)

- Short ($<1 \mu\text{s}$) proton pulses
- 1.3 GeV protons
- 45 pulses/second
- 1.8 MW, ramping up to 2 MW beam power
- 44.4 kJ per proton pulse
- Hg target
- Large beam footprint (140 cm²)
- 4 moderators (water & hydrogen)
- Moderator viewed area 10 x 12 cm²
- Coupled & decoupled moderators
- In operation since 2006

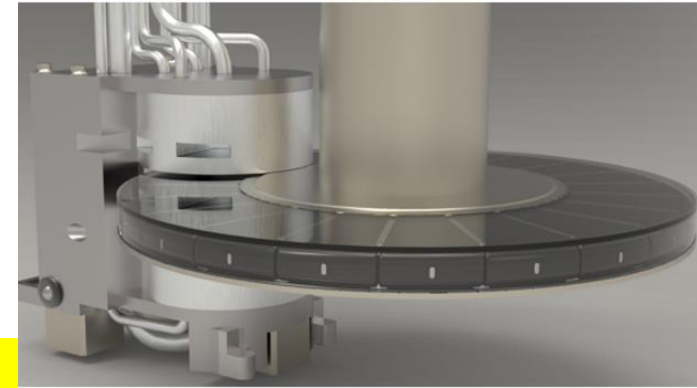

STS

- Short ($<1 \mu\text{s}$) proton pulses
- 1.3 GeV protons
- 15 pulses/second
- 700 kW beam power
- 46.7 kJ per proton pulse
- Rotating W target (Inconel shroud, water cooled)
- Smaller beam footprint ($\sim 60 \text{ cm}^2$)
- 2 coupled moderators (para-hydrogen)
- Moderator viewed area 3 x 3 cm²
- Start of operation $\sim 2037-2039$

ORNL Second Target Station (STS)

Srivastava et al., Nat. Comm. 2017
Banerjee et al., Science 356, 2017



- Highest peak-brightness short-pulsed spallation source of cold neutrons
- Smaller samples, more extreme conditions, shorter irradiation time
- Supports up to 18 neutron scattering and imaging instruments

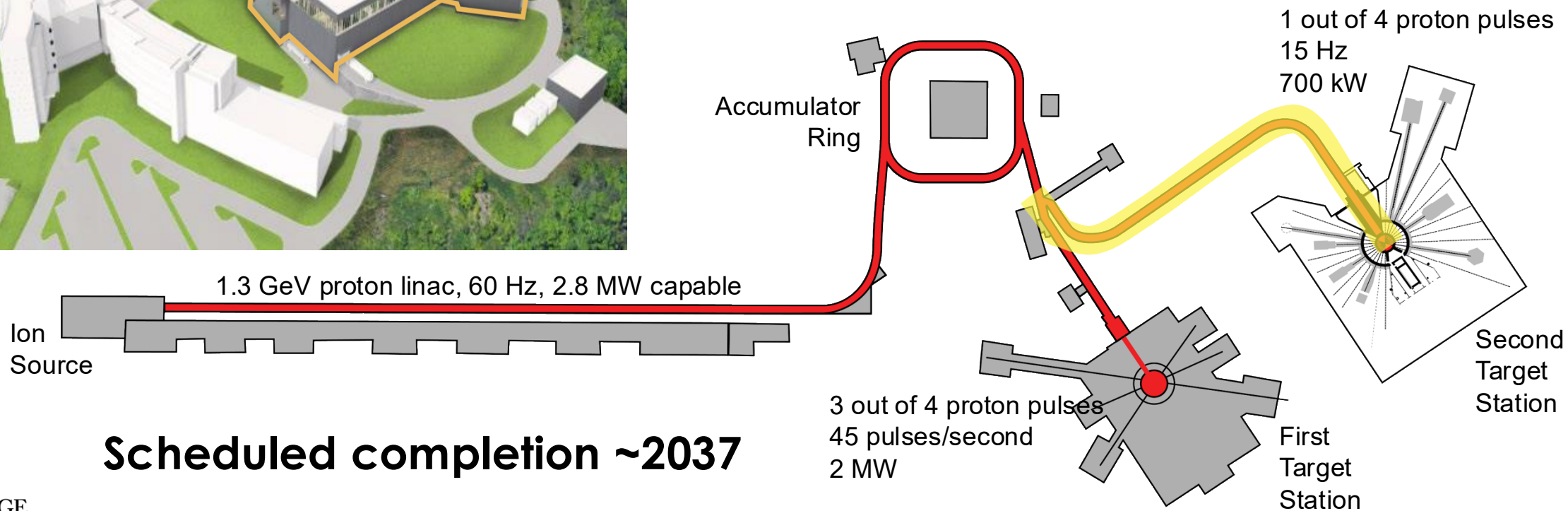
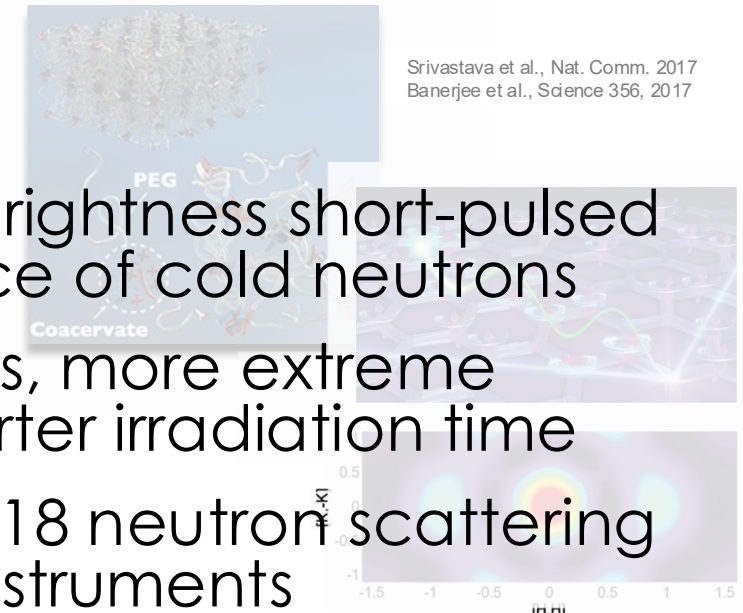

Scheduled completion ~2037

ORNL Second Target Station (STS)

- Rotating W target
- 1.3 GeV 700kW proton beam ($<1 \mu\text{s}$)
- Spallation neutrons moderated in coupled low-dimensional (flat) cylindrical and tube moderators designed for high brightness
- Para-hydrogen at 20 K
- Water premoderator, Be reflector
- Tightly coupled with the target
- **Neutronics support:**
- Neutron brightness, lifetime due to radiation damage (dpa), energy deposition, prompt and activation dose rates, radiation shielding

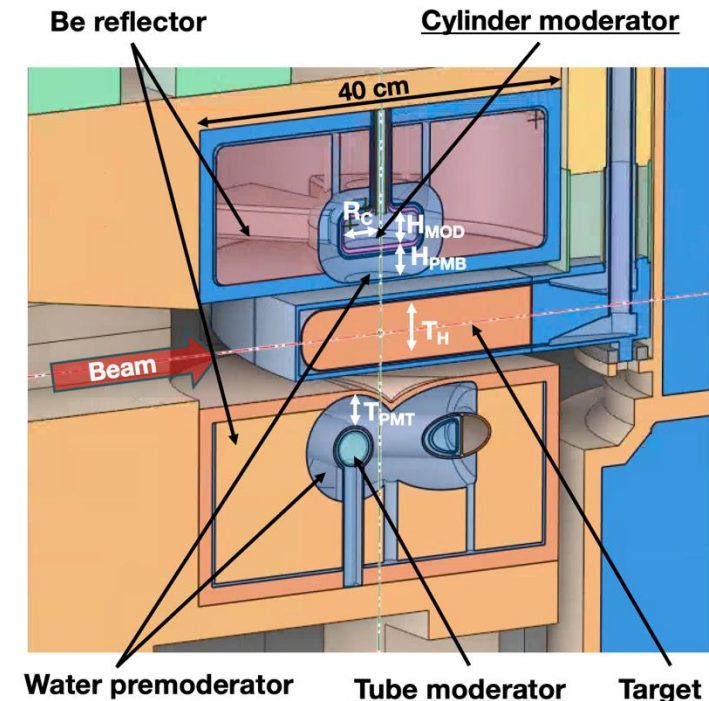
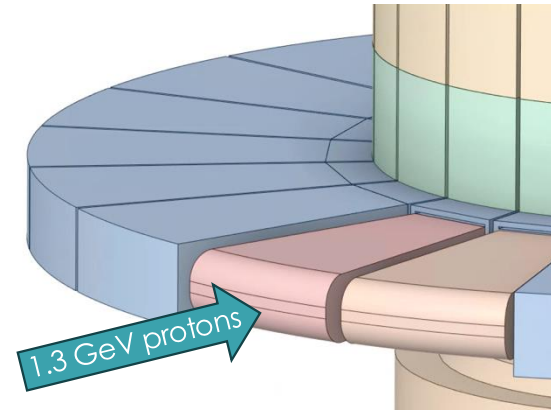
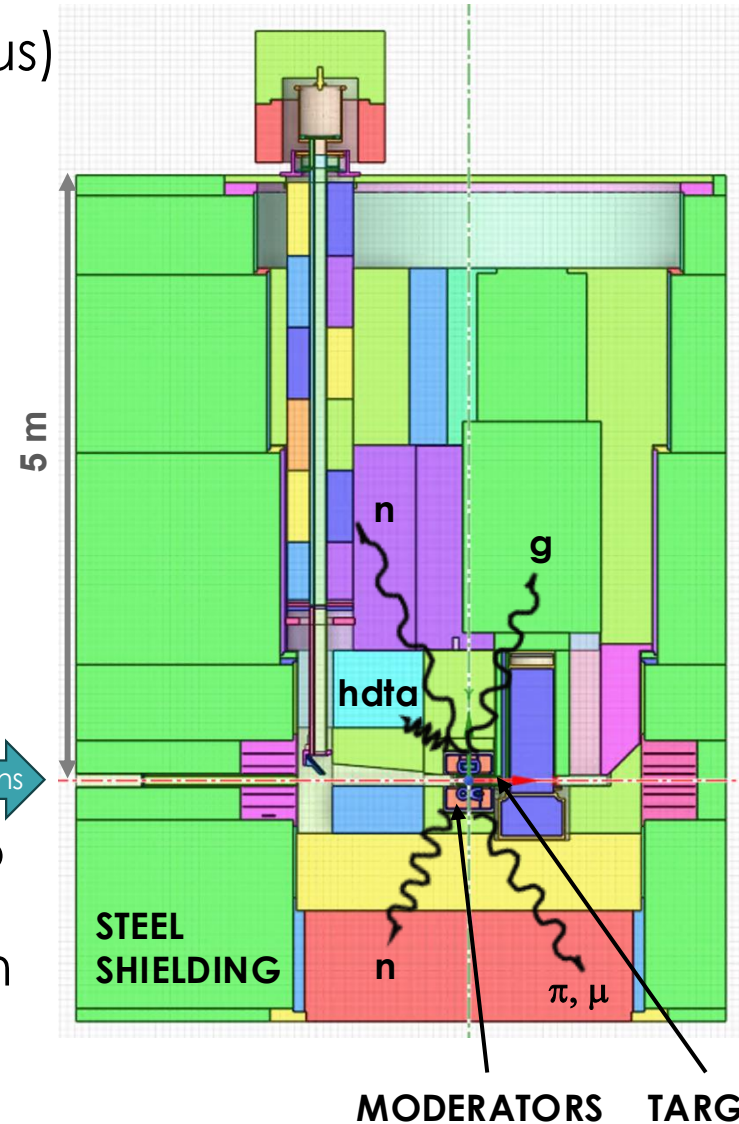

Extensive use of Unstructured Mesh (UM) at STS

- Modern radiation transport tools
- Automated CAD to MCNP conversion with Attila4MC
- CADIS/FW-CADIS variance reduction
- Advanced & coupled optimization

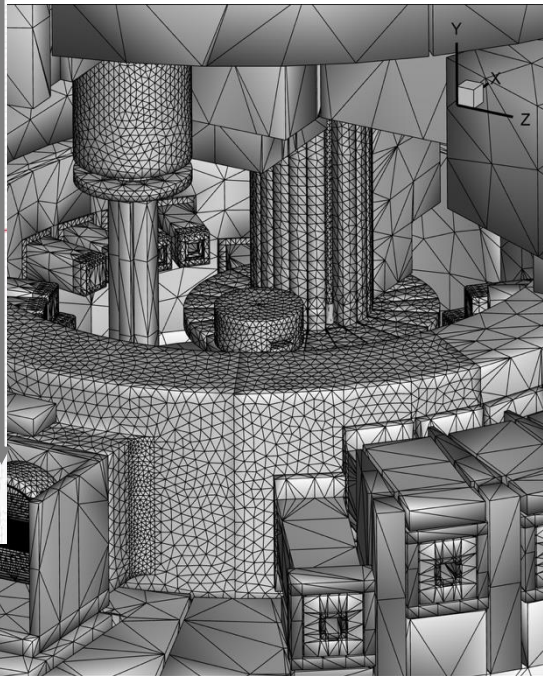
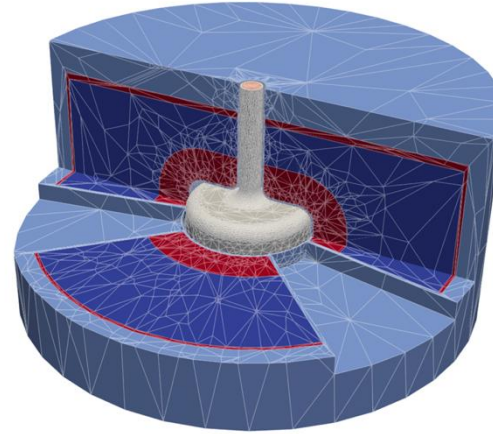
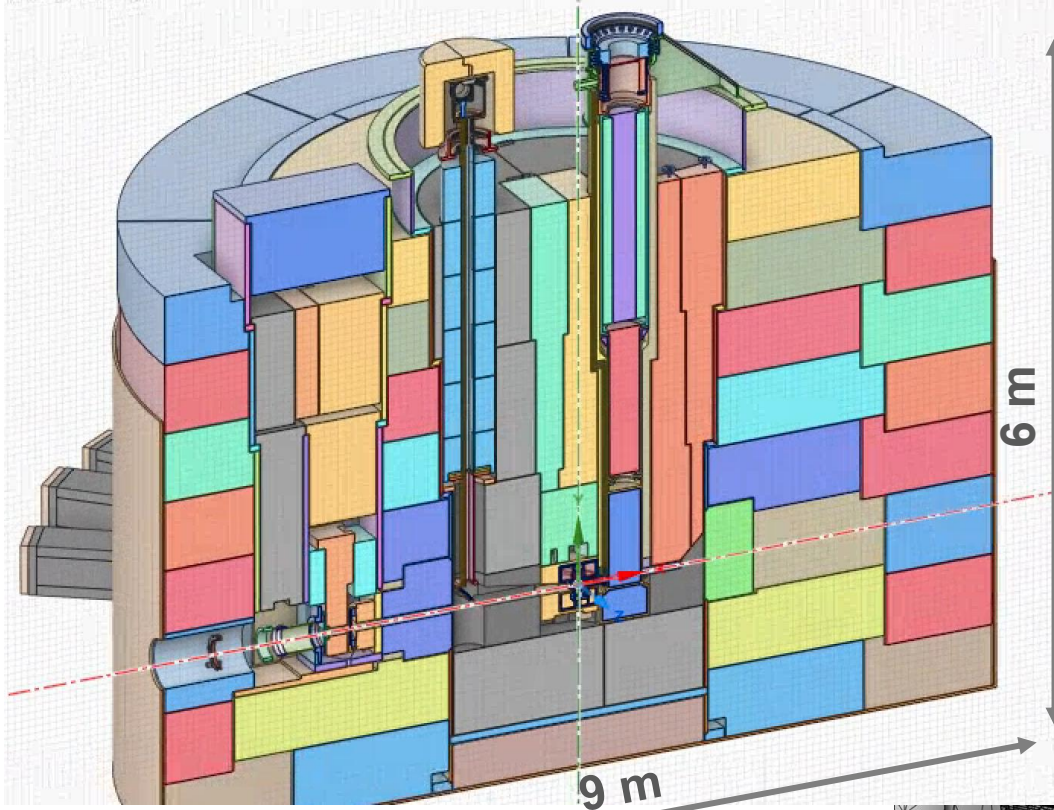

Extensive use of Unstructured Mesh (UM) at STS

Use of unstructured mesh models delivers high spatial-resolution data on **energy deposition** and **dpa** that provides input for structural analysis and determines lifetime

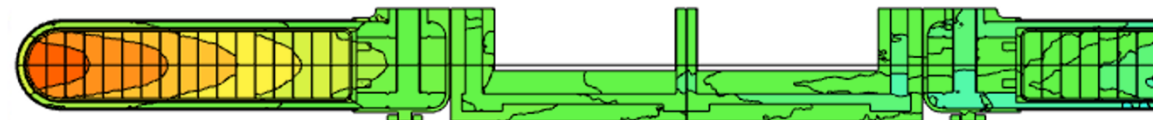
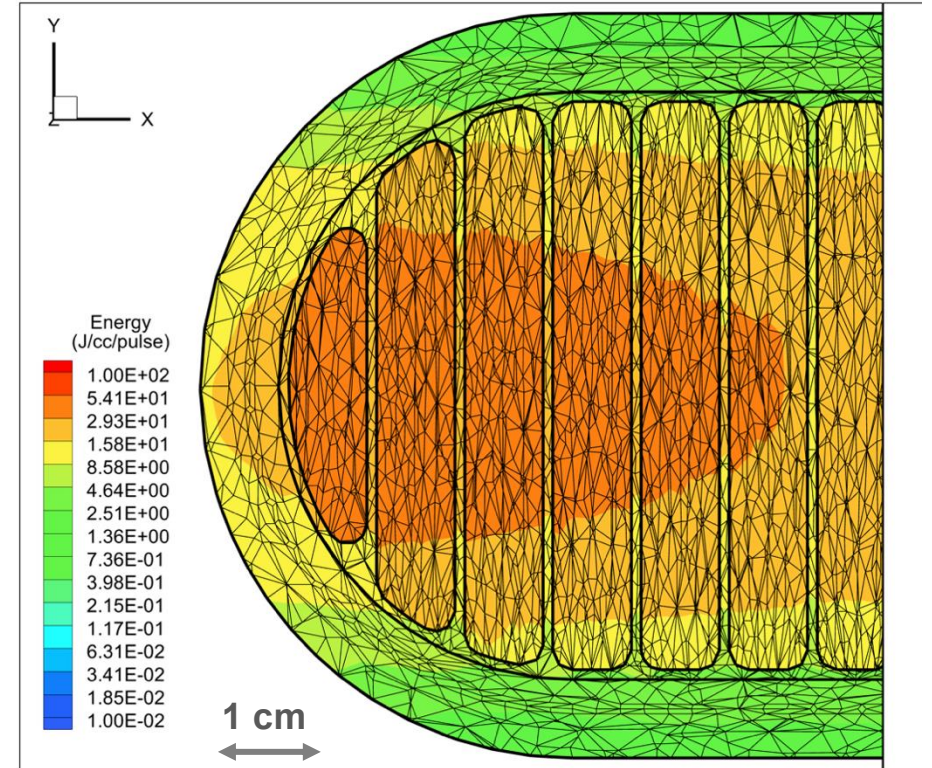
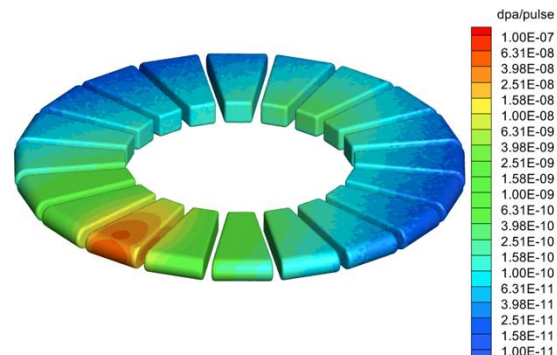
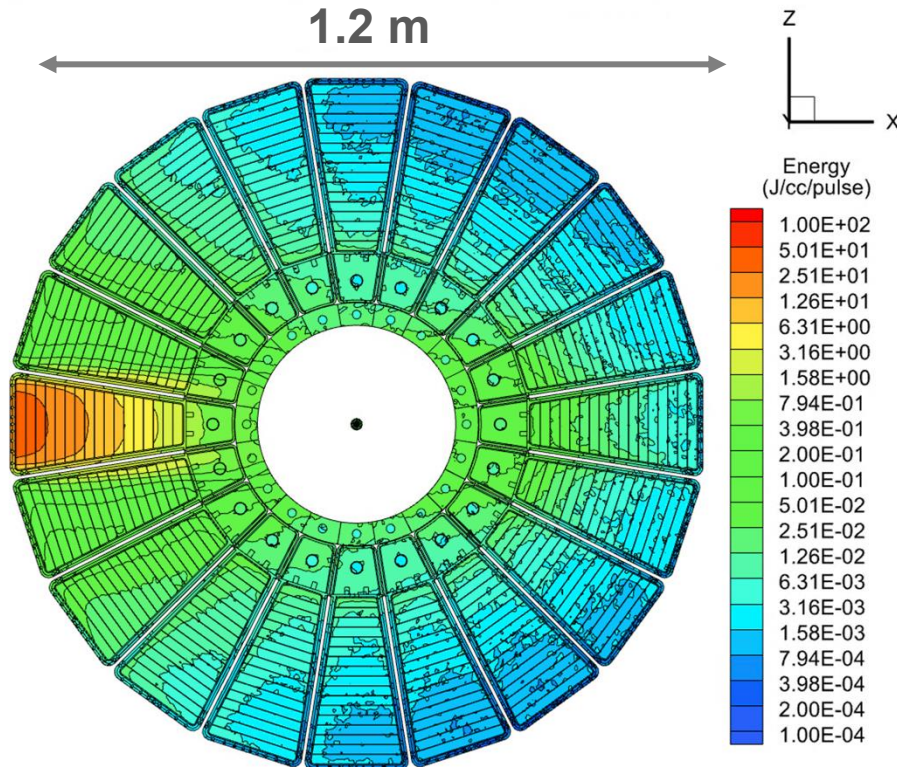
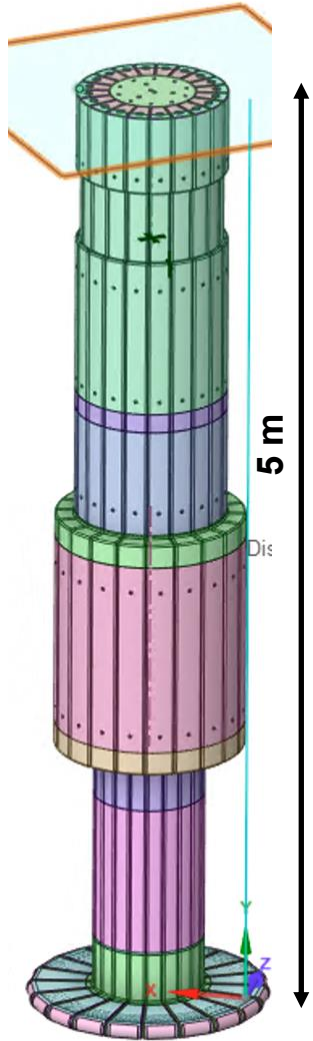

UM-based evaluation of various target designs

Monolithic

Frontal round

Tri plate

Canneloni

Wedge fondue

Lasagna

BLM He

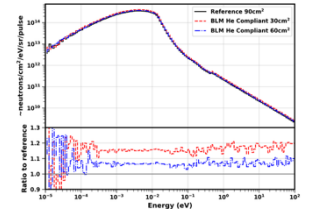
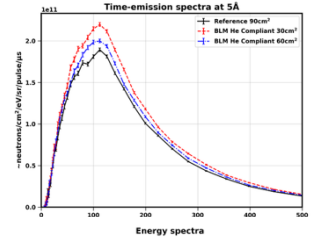
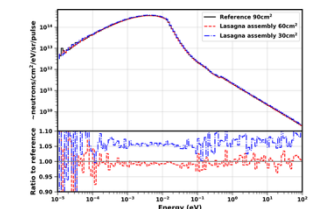
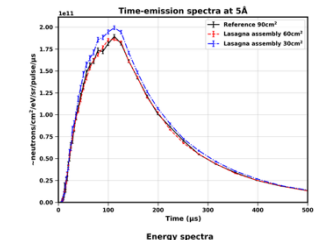
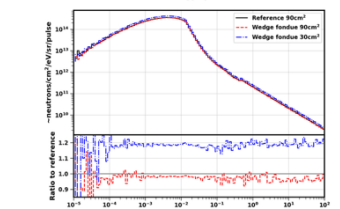
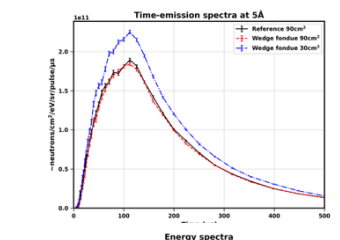
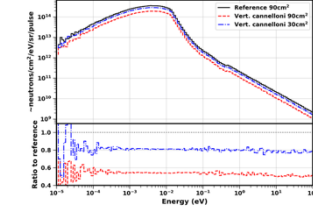
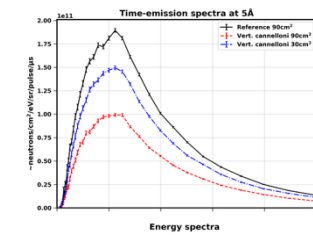
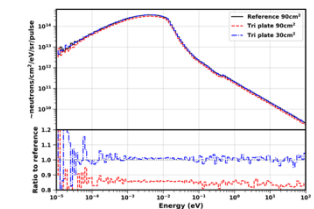
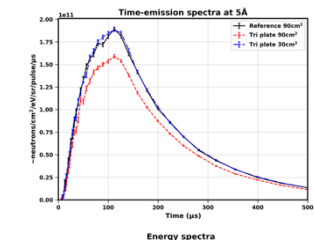
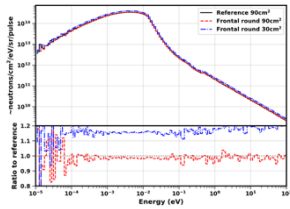
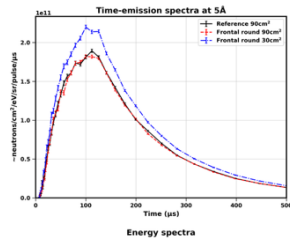
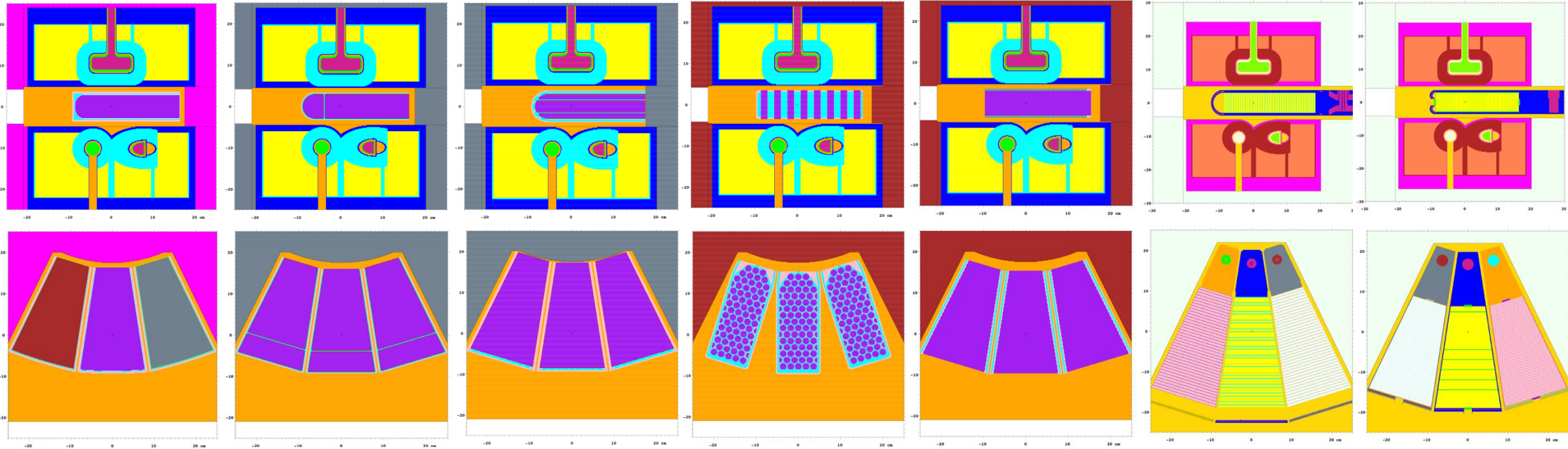

UM-based automatic multiphysics optimization workflow

Parametrization with CREO or SolidWorks

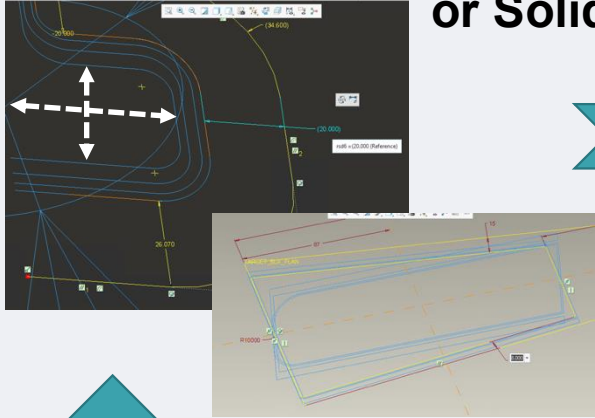

Design completion with SpaceClaim

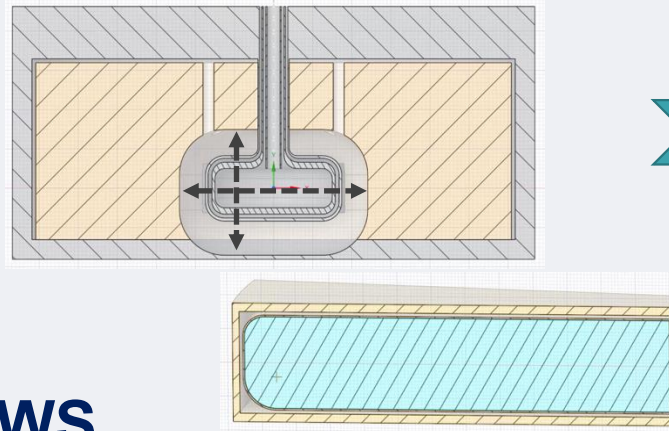

Unstructured Mesh (UM) generation with Attila4MC

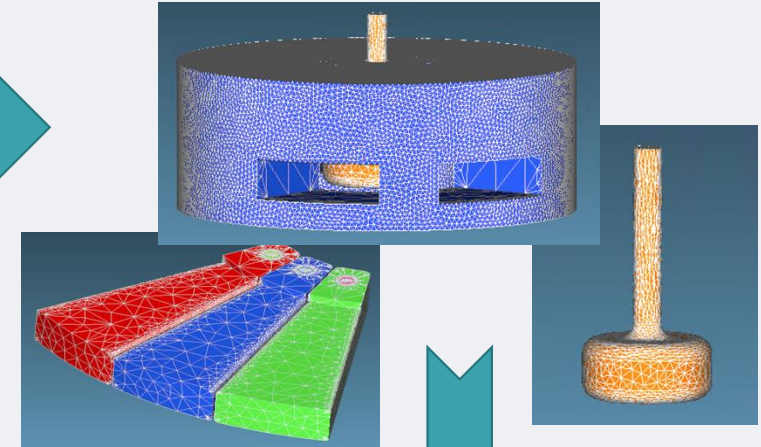

WINDOWS

DAKOTA Optimization

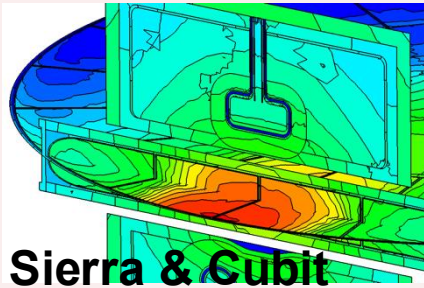

OPTIONAL

Structural analysis

LINUX

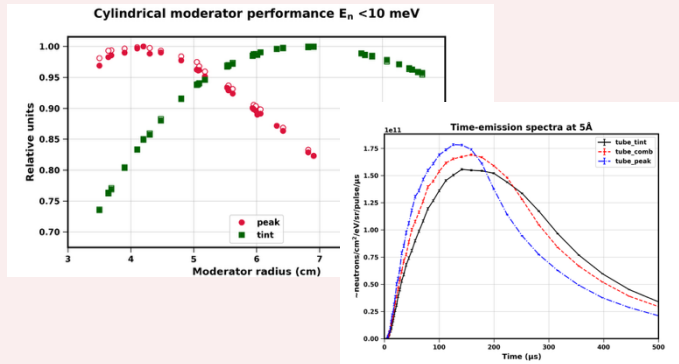

Neutronics analysis

MCNP6

Hybrid UM/CSG MCNP model

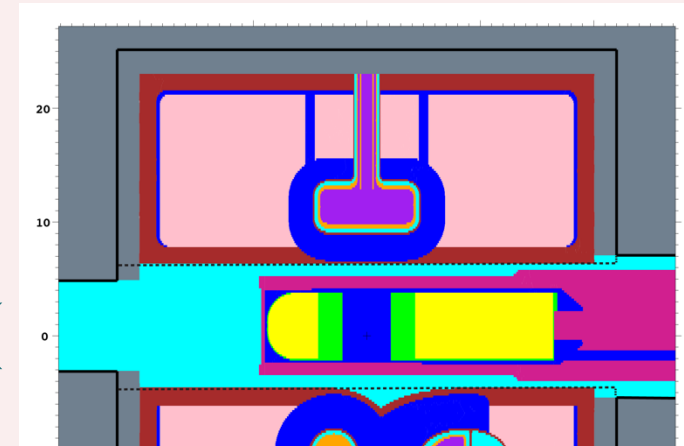

Coupled target-moderator-beam optimization

Cylindrical moderator: 6 parameters

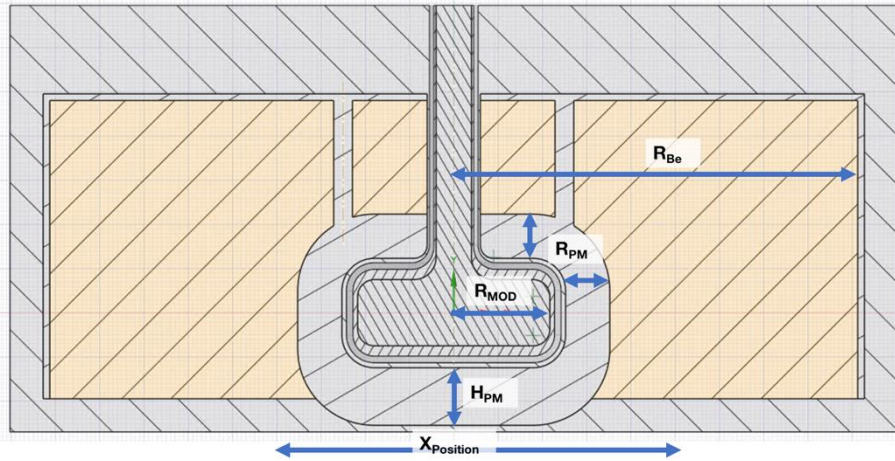

	min	max
Rh2 (mm)	35	80
t_pm_side (mm)	15	40
t_pm_bot (mm)	15	40
t_pm_top (mm)	10	40
r_be (mm)	175	200
x_shift (mm)	-20	20

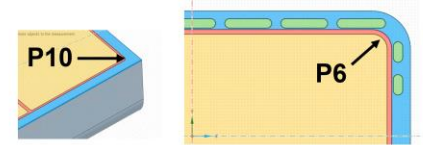
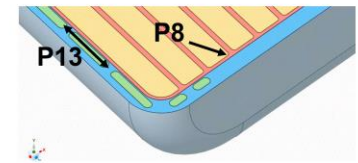
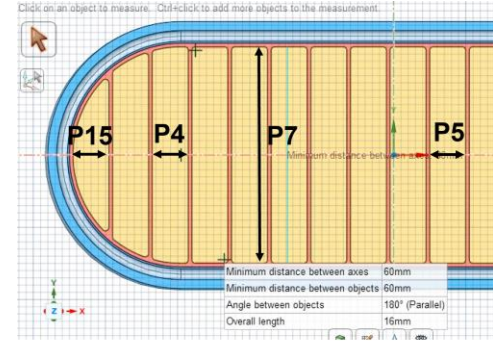
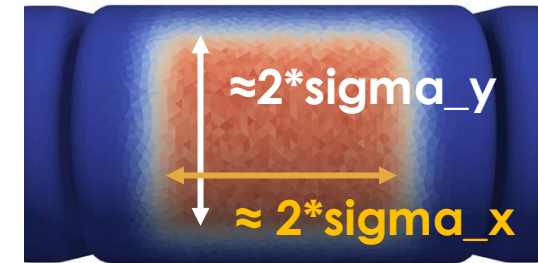

Tube moderator: 7 parameters

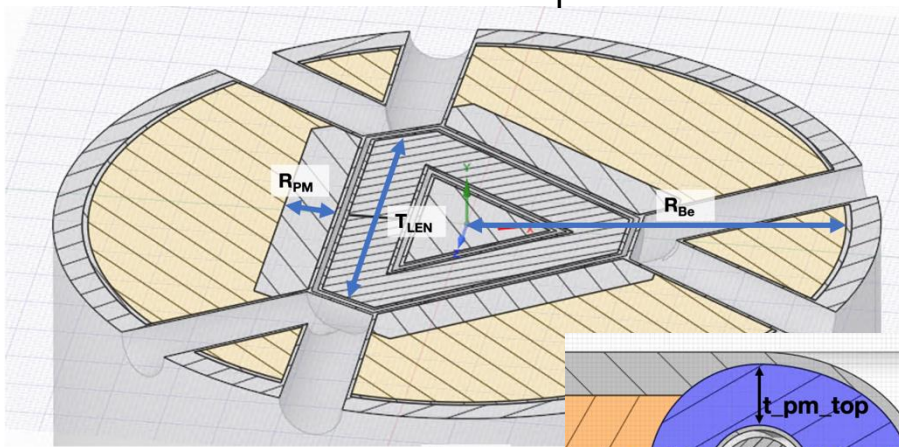

	min	max
T_len (mm)	120	240
t_pm_top (mm)	10	35
t_pm_right* (mm)	25	35
t_pm_bot (mm)	10	35
t_pm_left* (mm)	10	35
r_be_t (mm)	175	200
x_shift (mm)	-20	20

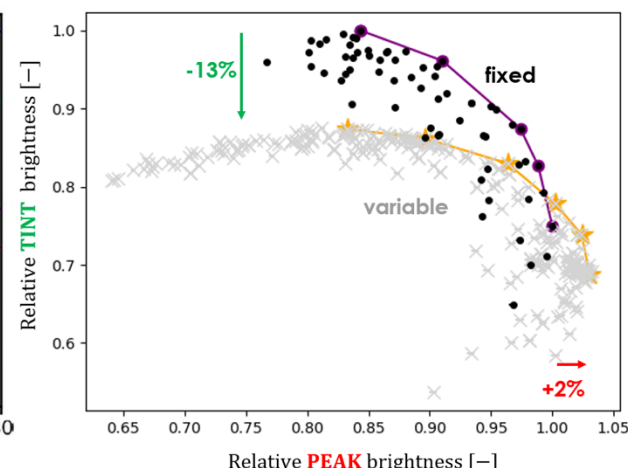
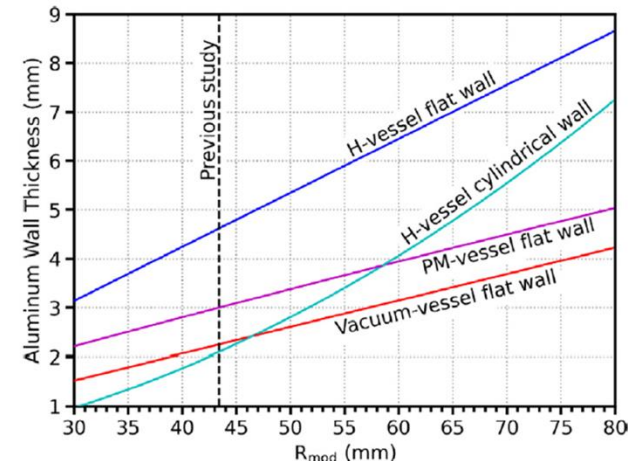
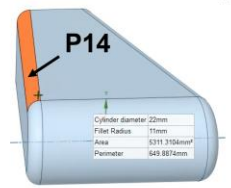
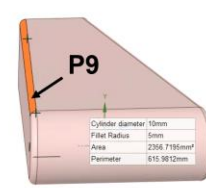
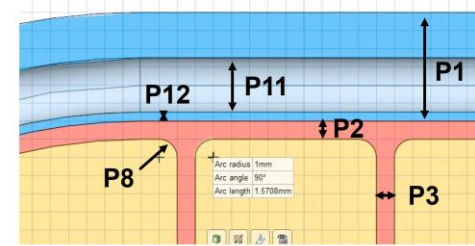

Coupled neutronics-structural stress optimization

- Simultaneous calculations of brightness and energy deposition
- Factor of safety (Measure for the mechanical performance, Goodman diag.)

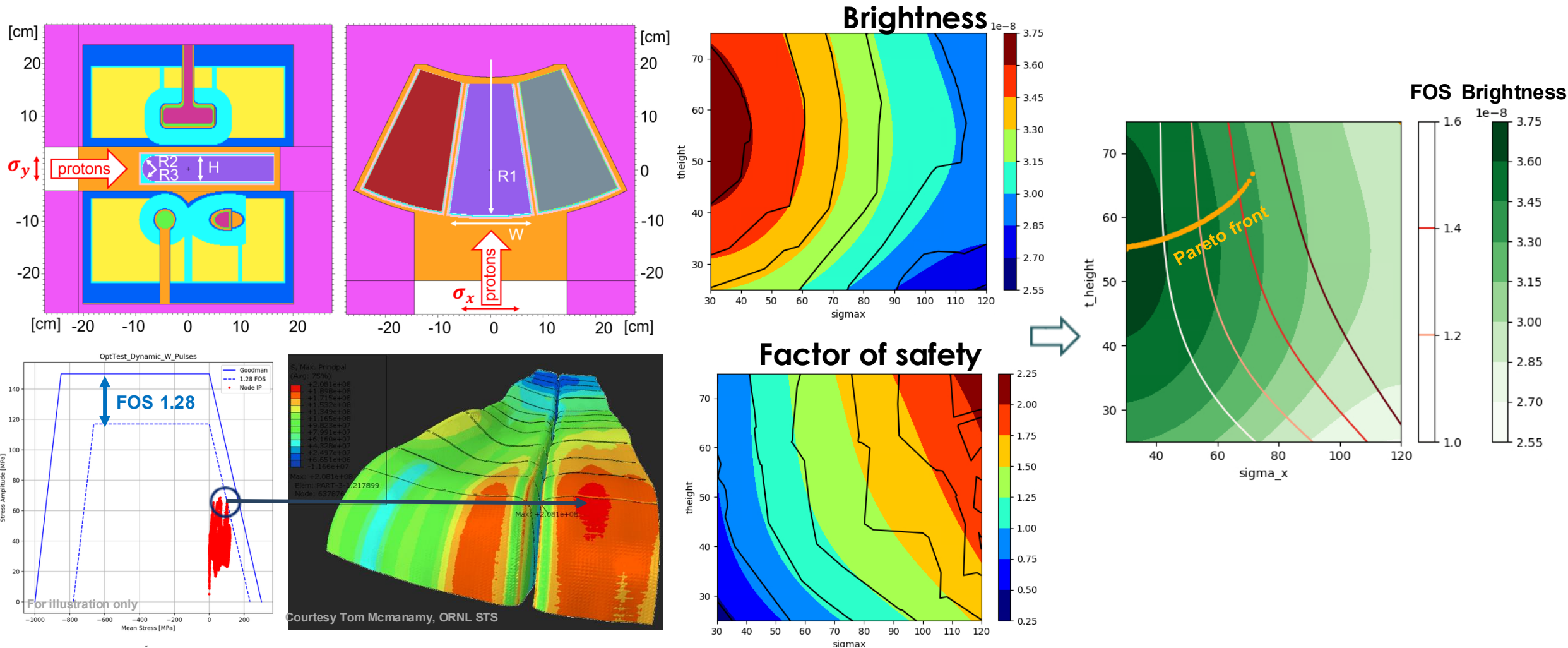

Final design neutronics calculations

- Final design reviews scheduled for the summer of 2026
- Target and shaft
 - Final energy deposition under various protons beam conditions
 - Final radiation damage calculations
 - Temperature sensitivity studies (only tables, no model sensitivity)
- Moderators
 - Optimization of the final-design geometry
 - Final neutronics evaluation
 - Final energy deposition and radiation damage calculations
 - Sensitivity studies

Target and shaft final design

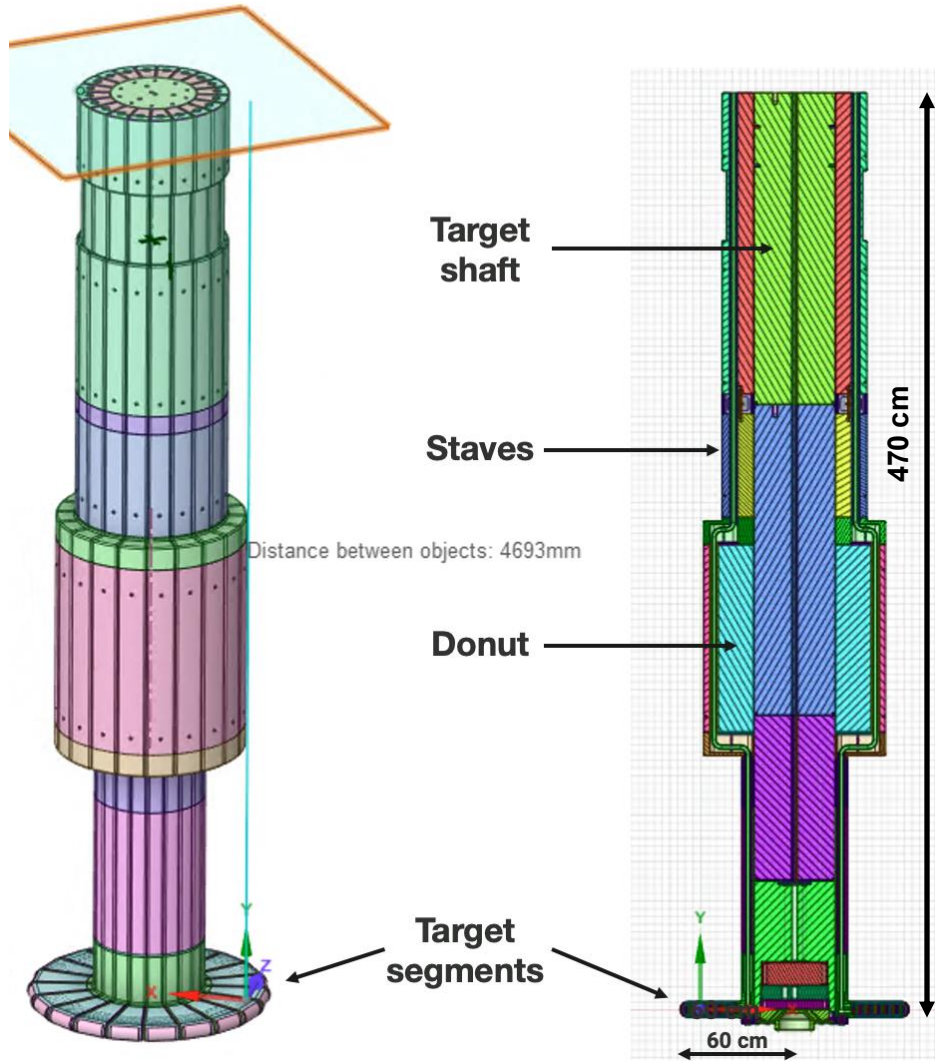

- Attila4MC's Part-By-Part (PBP) mesher
 - More efficient meshing with "dirty" models
 - Faster running time (hours > minutes)
- Cottonwood deterministic solver
 - CADIS/FW-CADIS with arbitrary mesh refinement
 - Discontiguous mesh with voids and overlaps
 - Runs faster

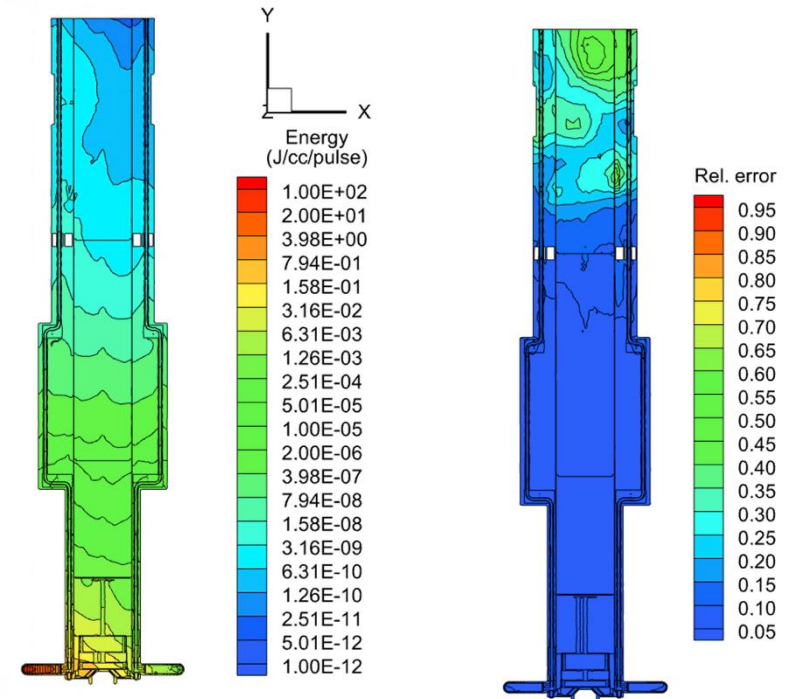

Target heating for different proton beam conditions

Nominal 60 cm²

Total 378 kW
Tungsten 293 kW
Max 38.1 J/cc/pulse

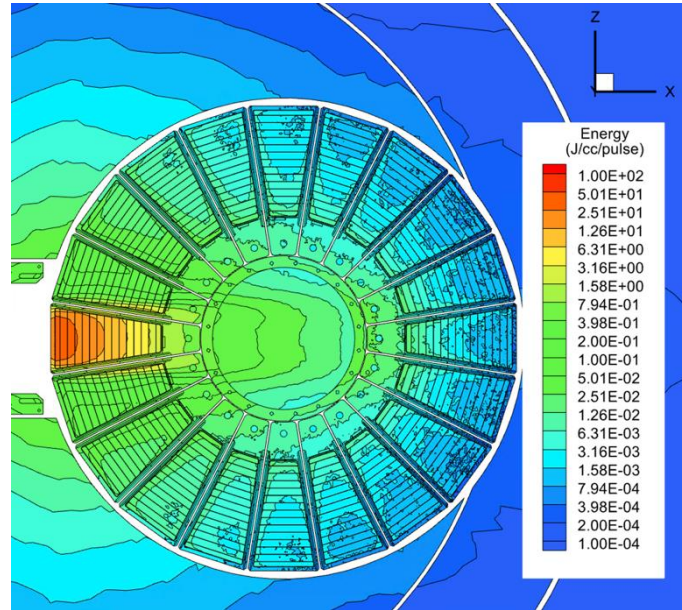

Nominal Corner

Total 370 kW
Tungsten 274 kW
Max 38.2 J/cc/pulse

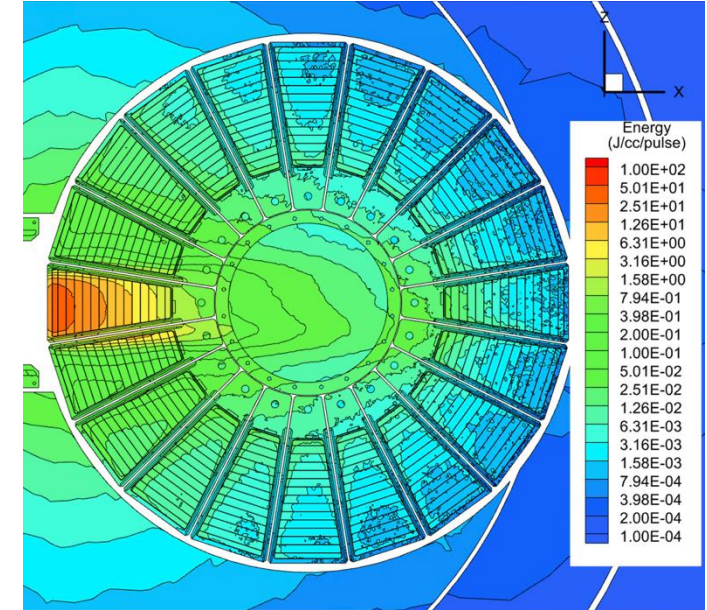

Overfocused 57 cm²

Total 379 kW
Tungsten 296 kW
Max 40.0 J/cc/pulse

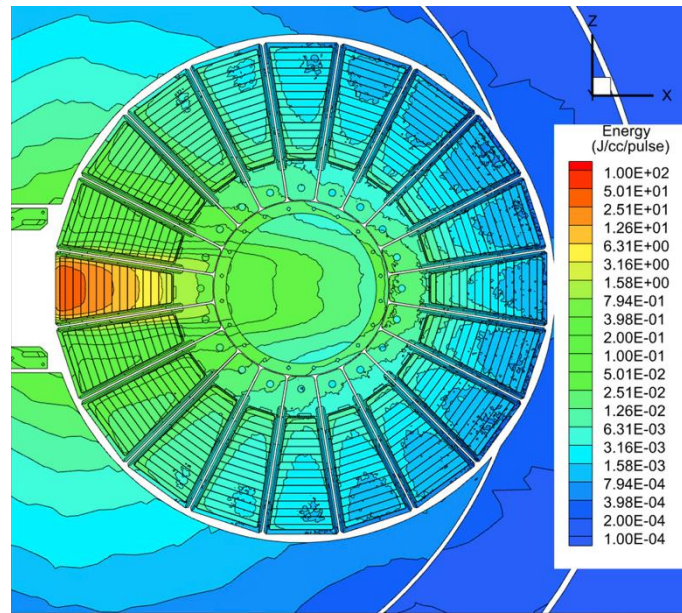

Diffused 94 cm²

Total 371 kW
Tungsten 263 kW
Max 25.8 J/cc/pulse

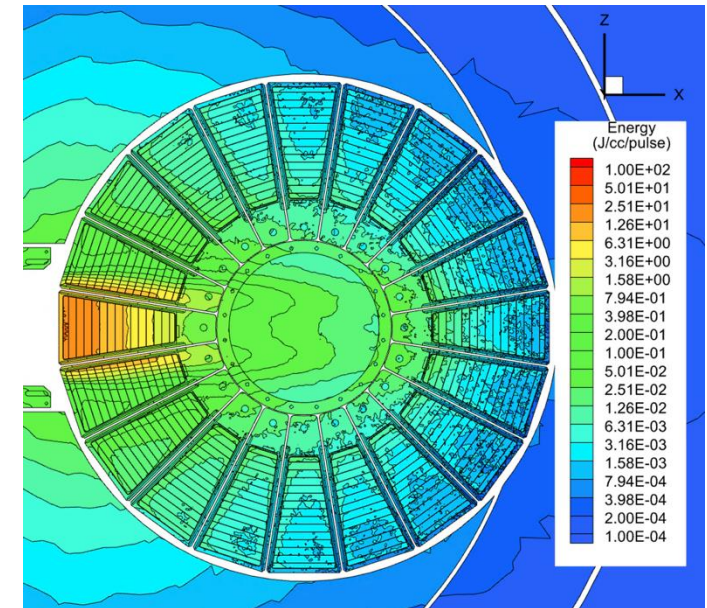

Radiation damage for target and target shaft

Tungsten: 8 dpa /10 years
Limit: -- (not structural)

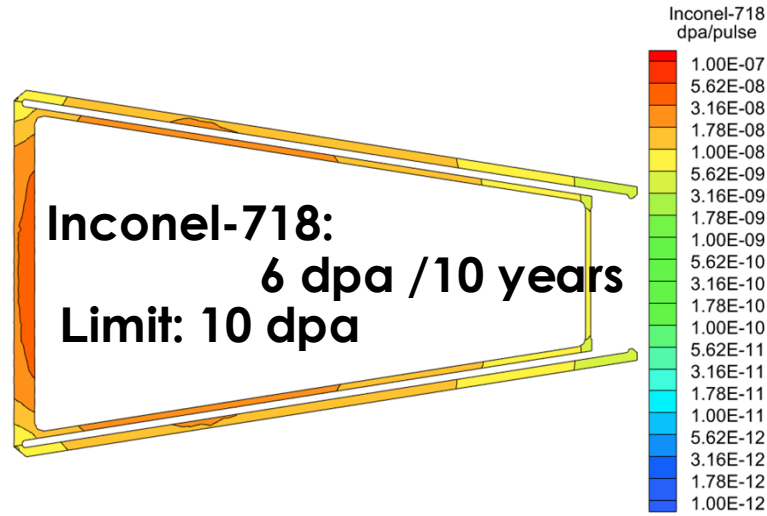
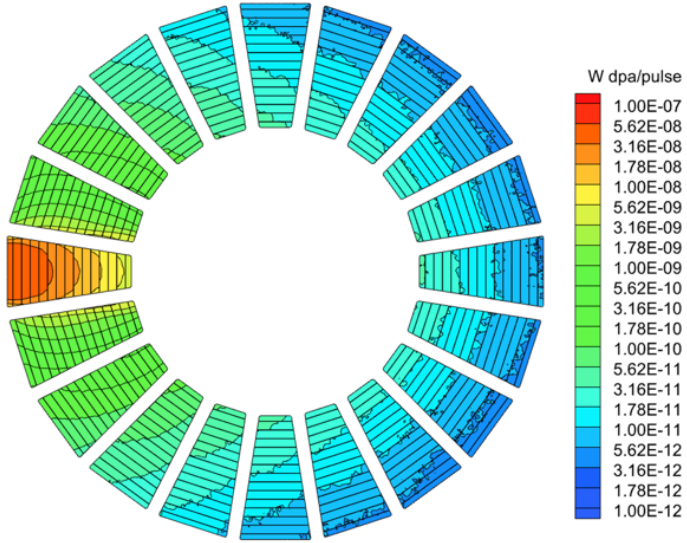

Stainless Steel Shaft
Max: 4.8 dpa / 40 years
Limit: 15 dpa

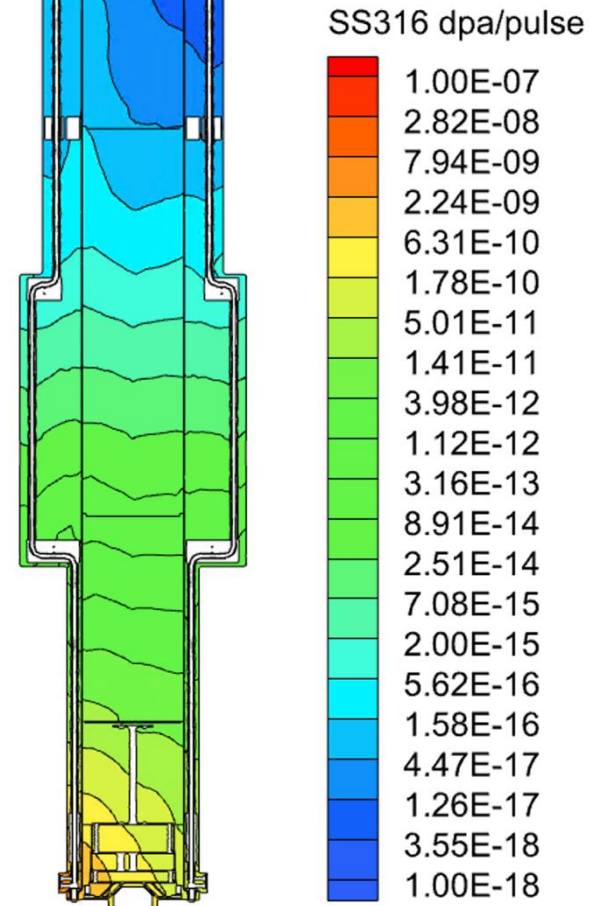

Tantalum: 8 dpa /10 years
Limit: 9 dpa

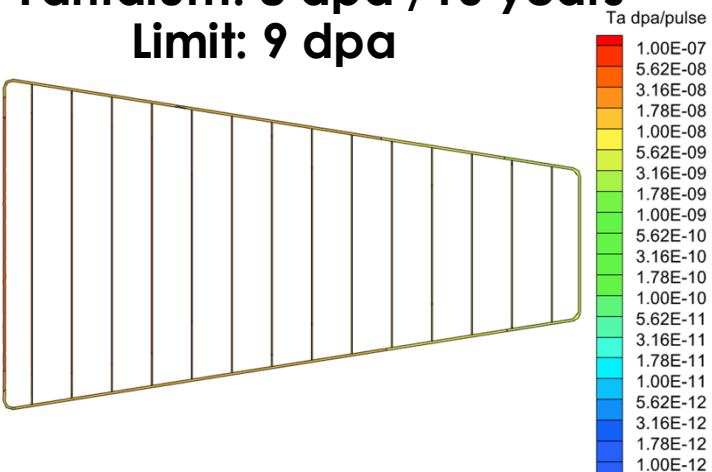

Stainless steel: 1.7 dpa /10 years
Limit: 15 dpa

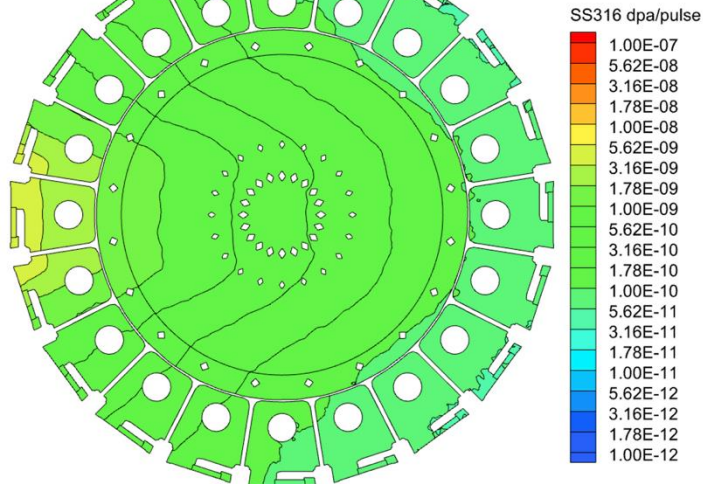

Moderators final design - optimized

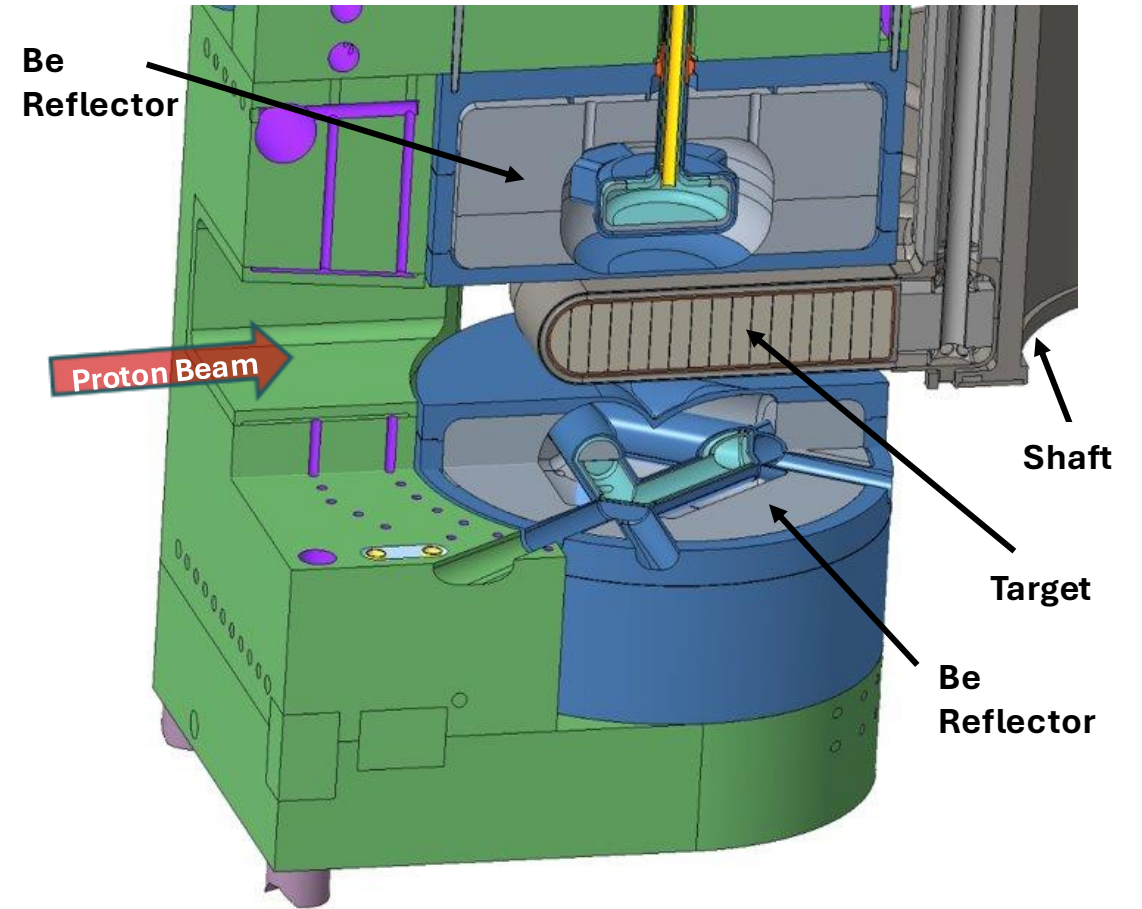
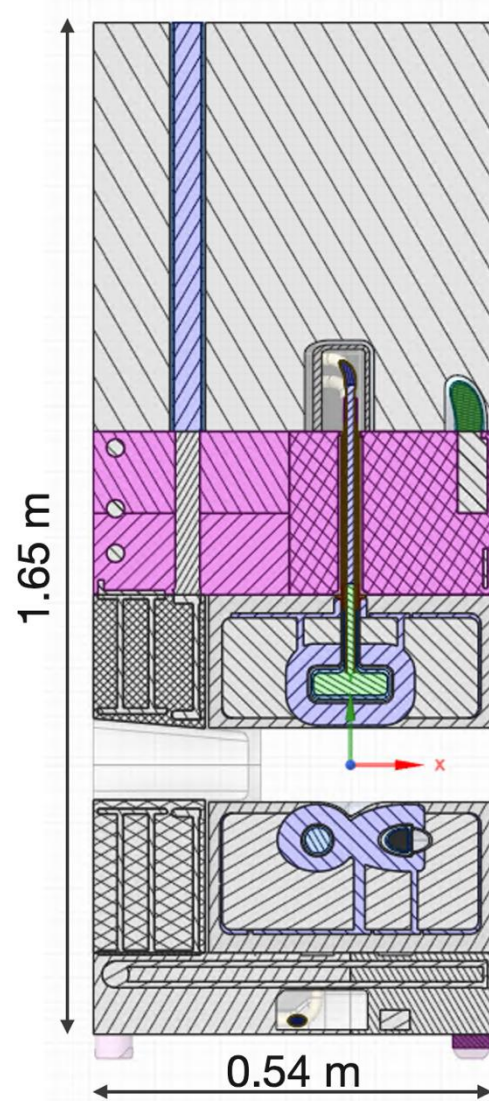
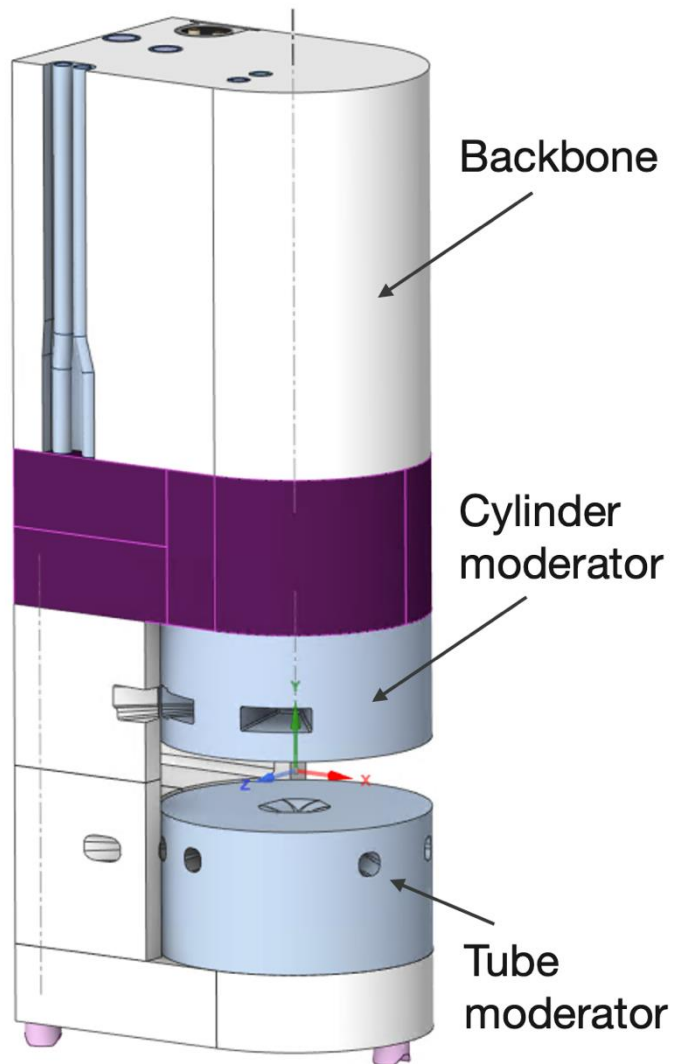

Moderators final design

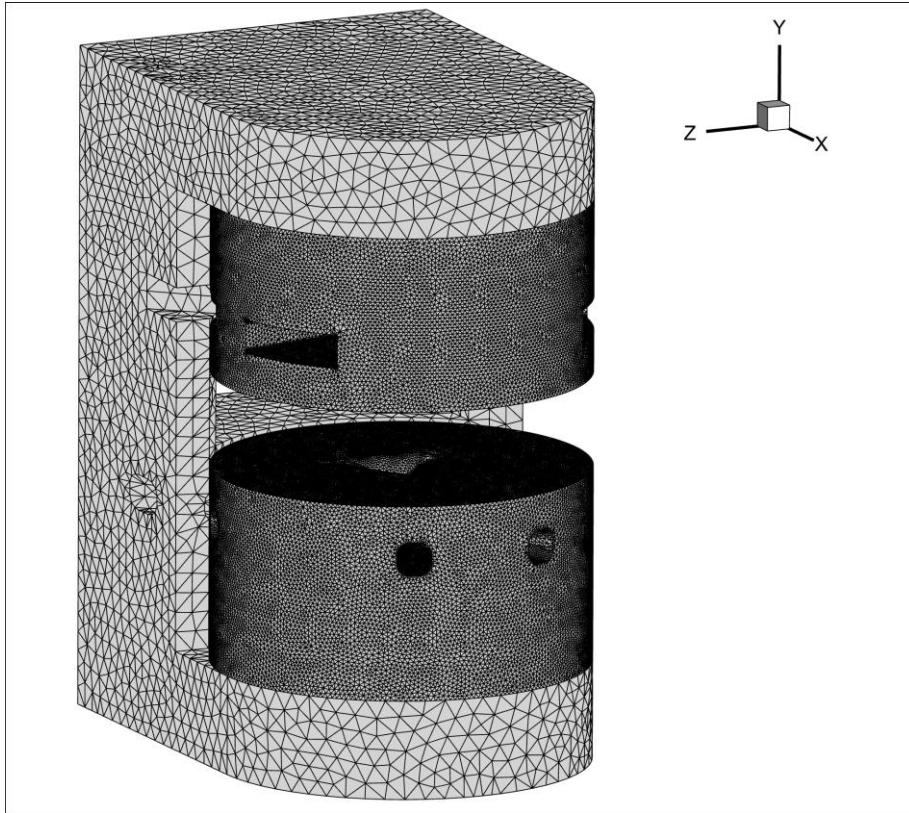

UM captures all fine curvatures (difficult to achieve with CSG)

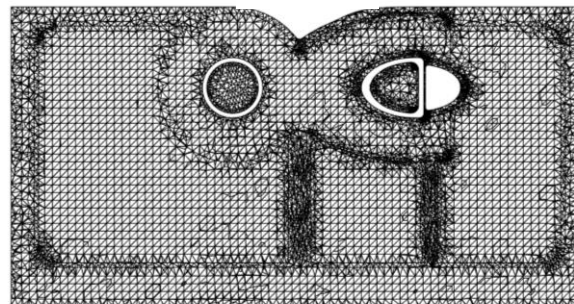
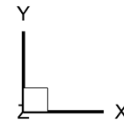
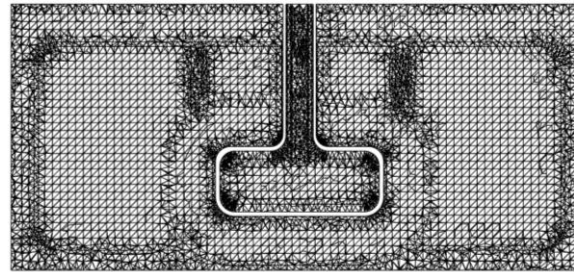
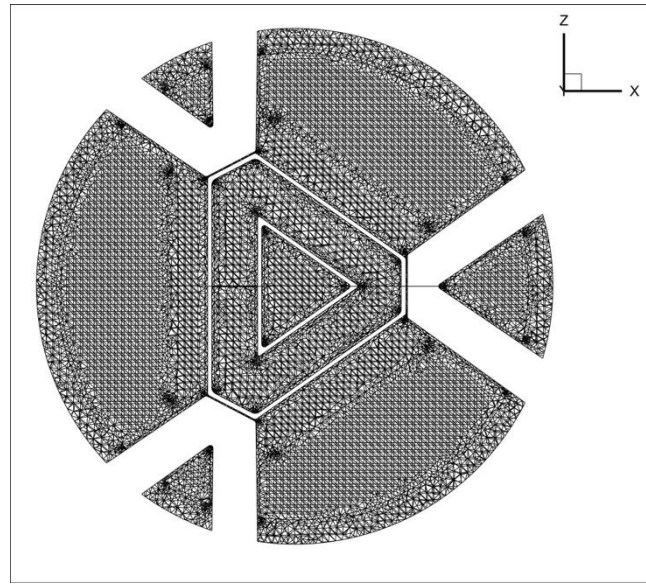
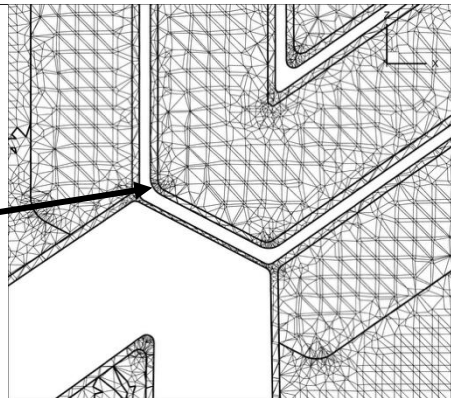

Cylinder hydrogen vessel

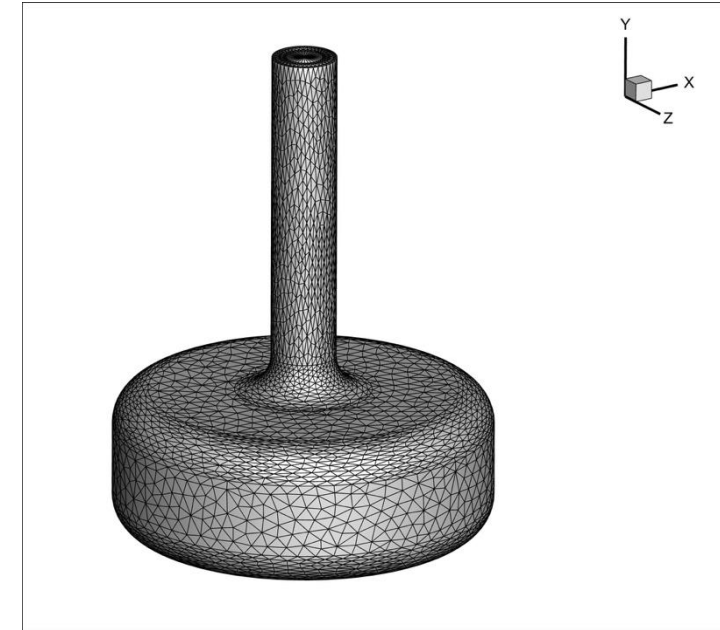

Tube hydrogen vessel

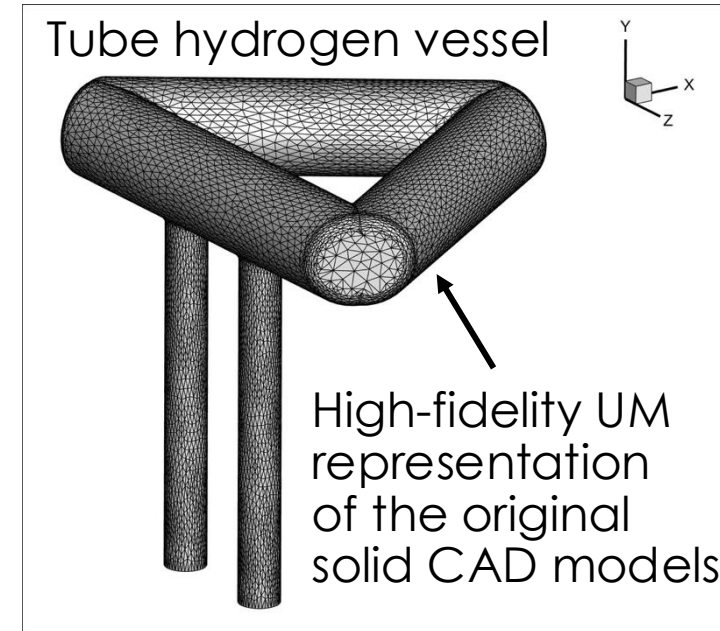

High-fidelity UM representation of the original solid CAD models

Final design neutronics performance

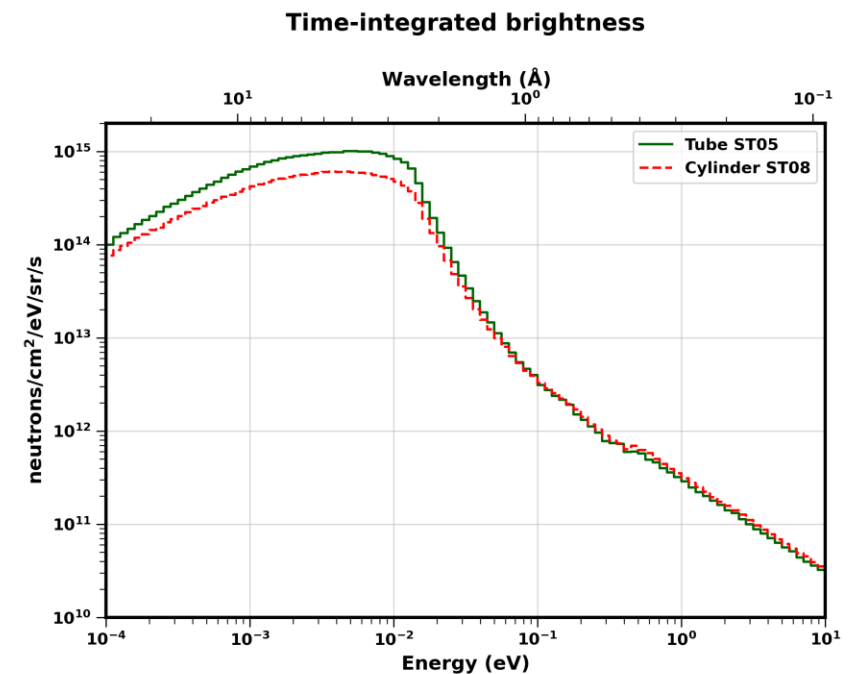
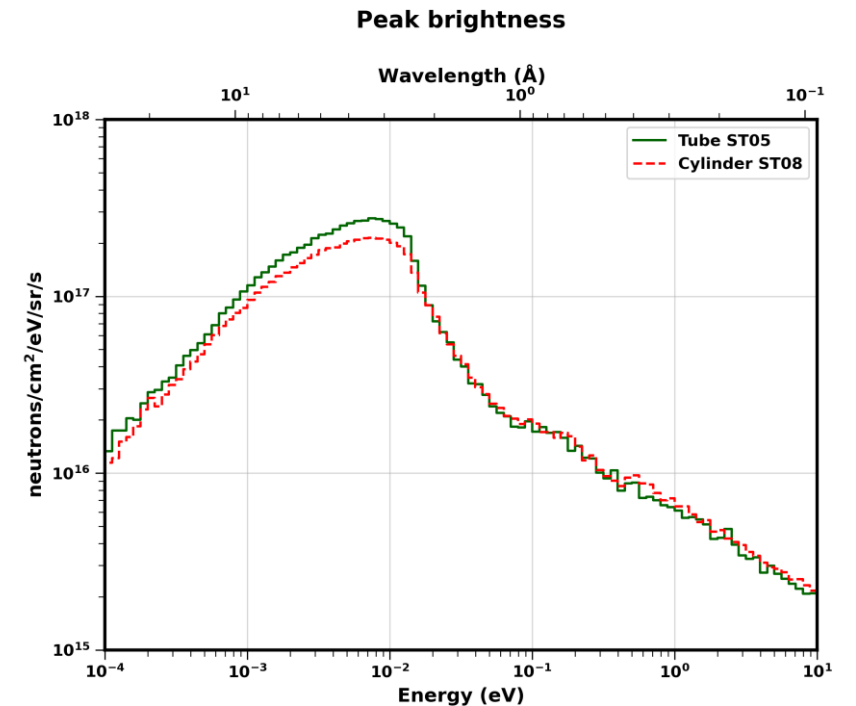
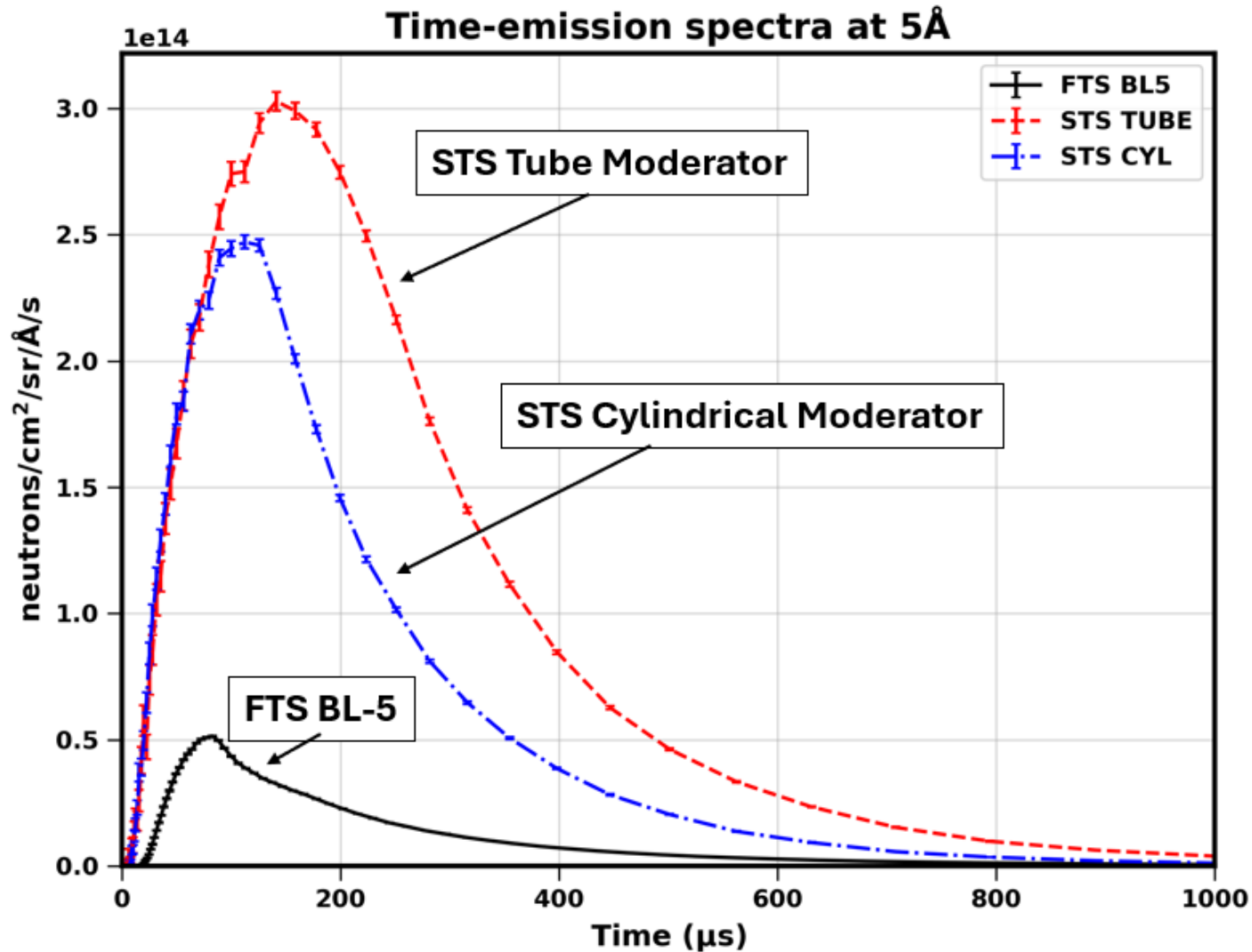

MRA lifetime and heating rates

- Total heating (including $^{27}\text{Al}(n,g)$)
 - MRA: 31.2 kW
 - Backbone: 27.2 kW
- Lifetime ~ 6.5 years due to dpa in Al
 - Assuming 40 dpa limit
 - Limiting is dpa in Al
 - Maximum 6.2 dpa/year
 - Si production not limiting
 - dpa in steel backbone not limiting

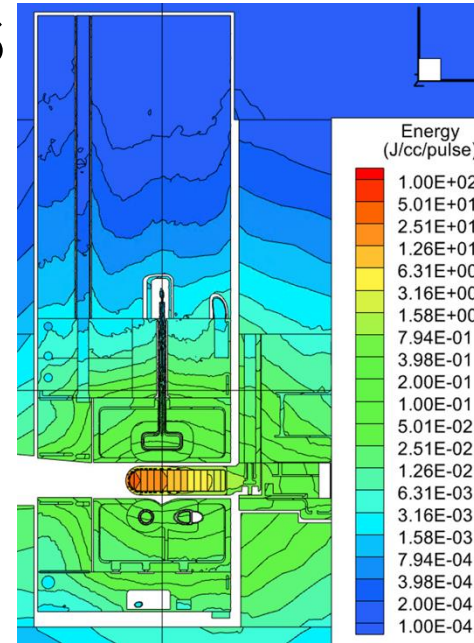

Si production (thermal flux)

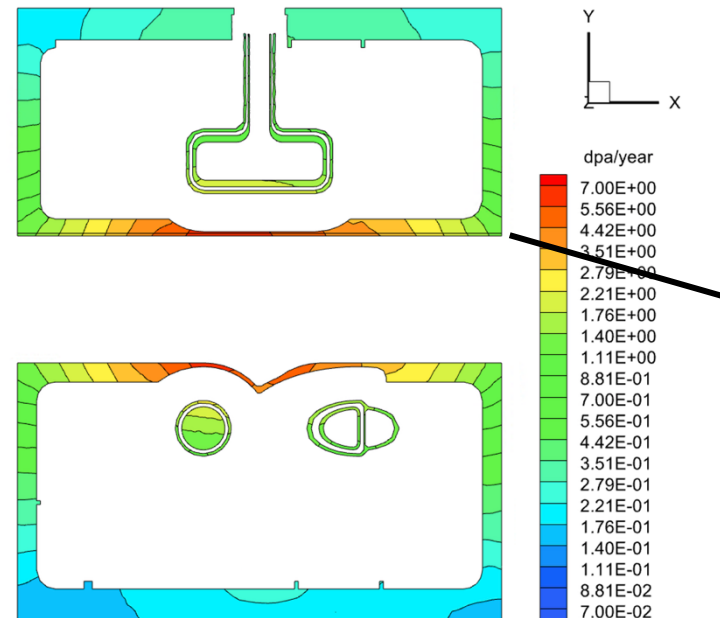
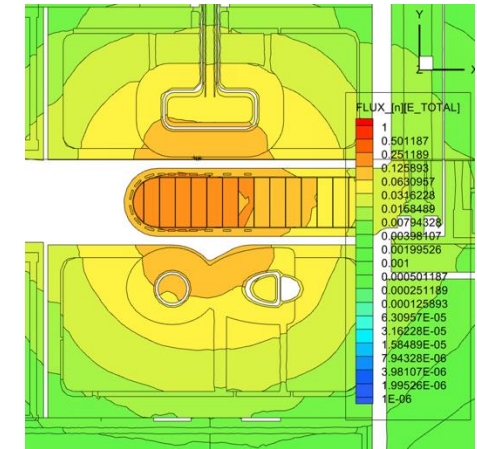

Cylinder bottom

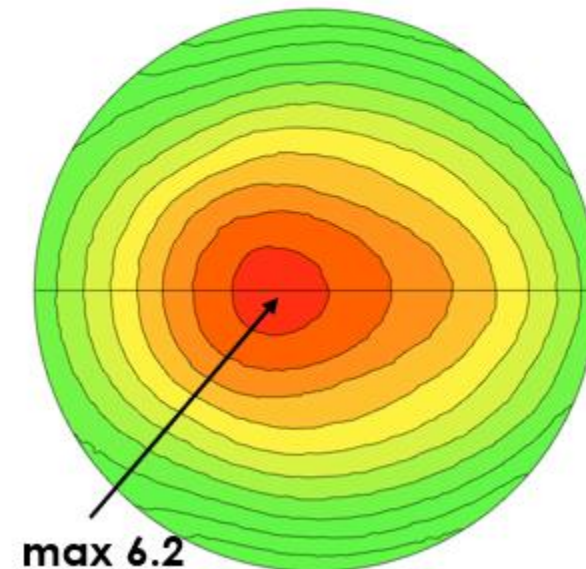

Hydrogen ortho/para fraction sensitivity study

- Default para-hydrogen fraction is 99.9%
- Sensitivity study was performed in the range of 95% to 100%

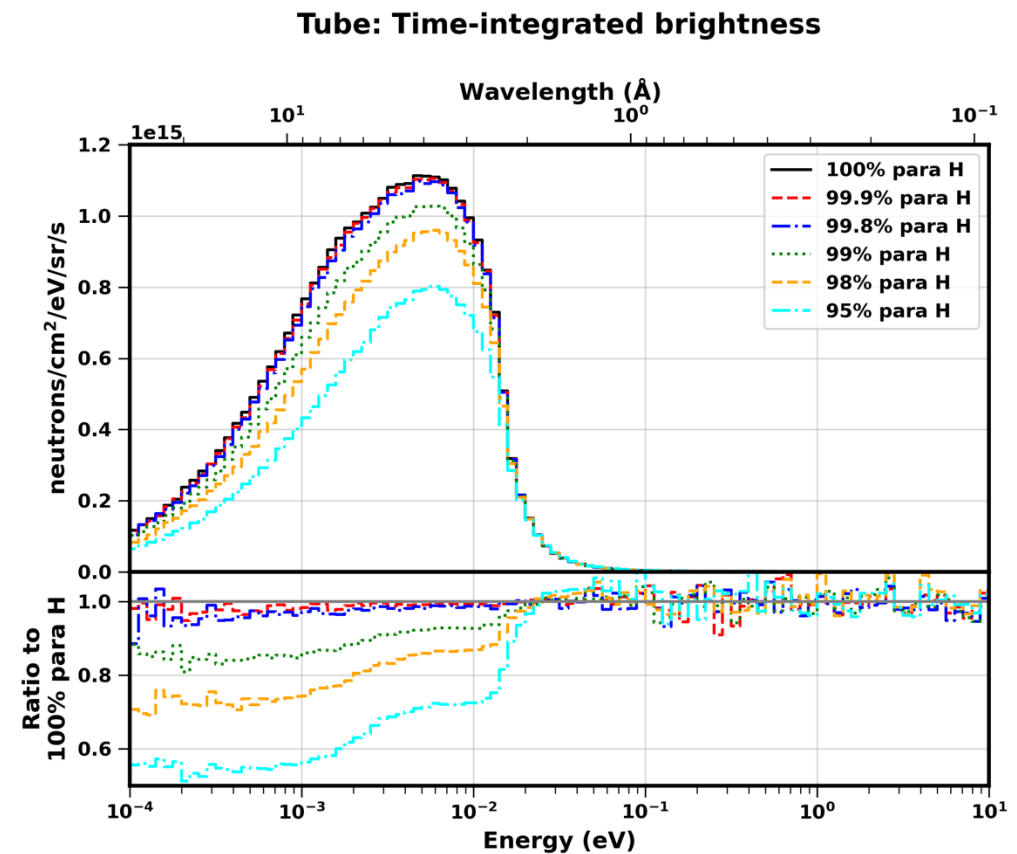
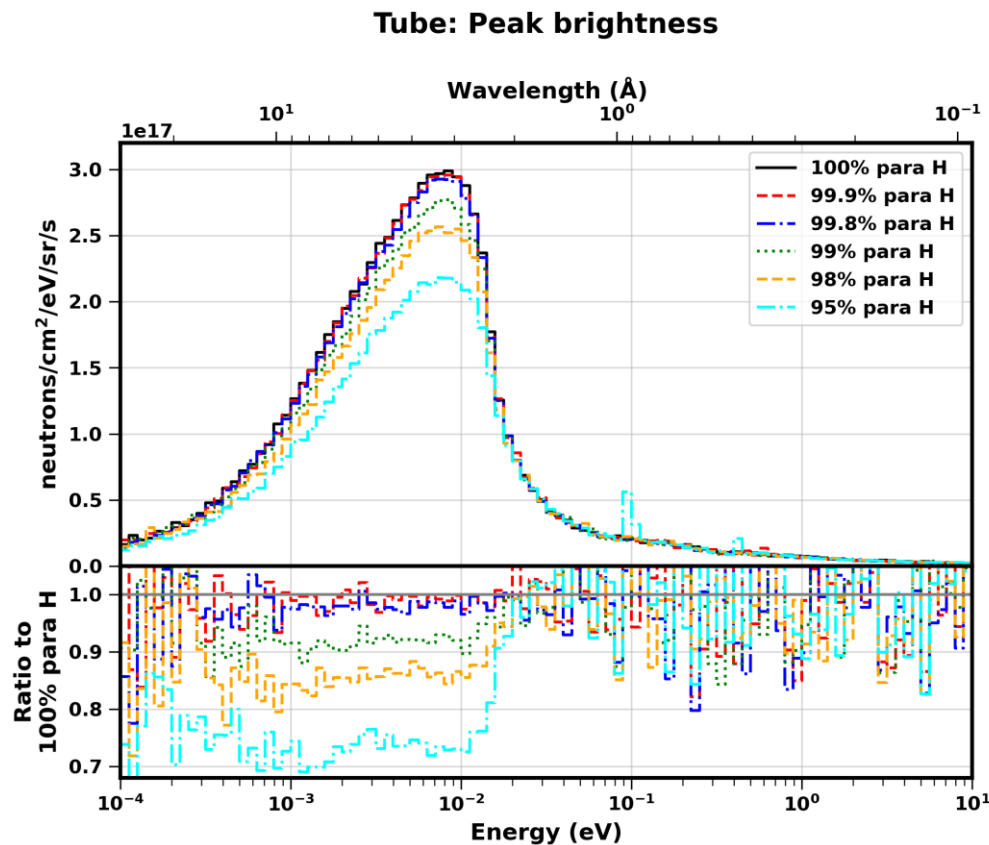

Hydrogen temperature sensitivity study

- Default hydrogen temperature is 20 K
- Sensitivity study was performed in the range of 18 – 22 K

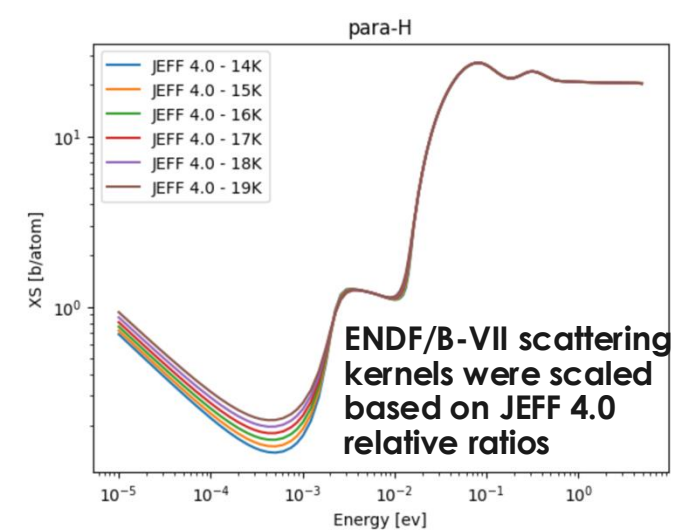

Peak brightness

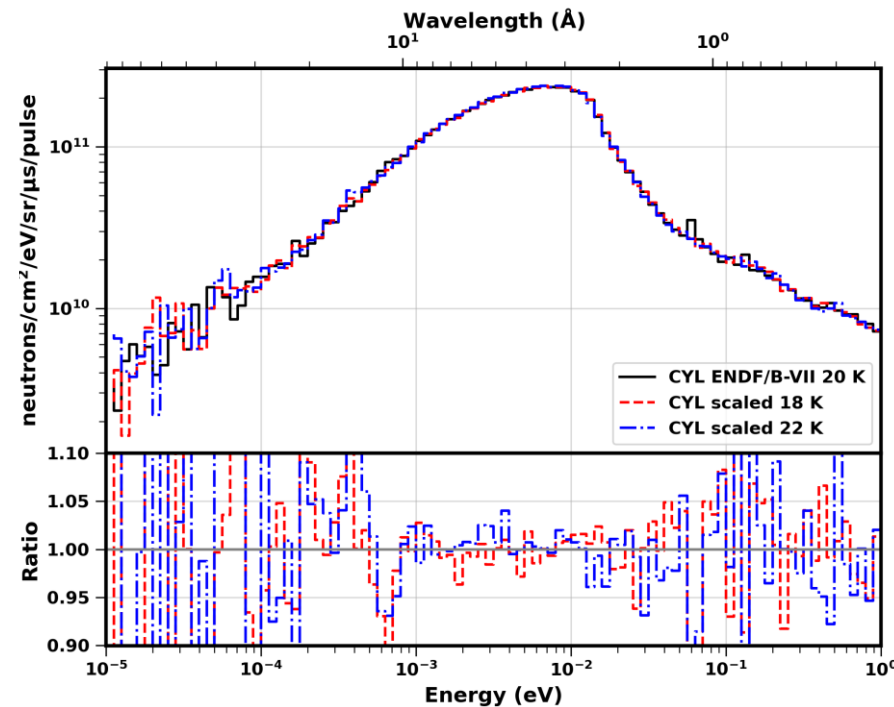
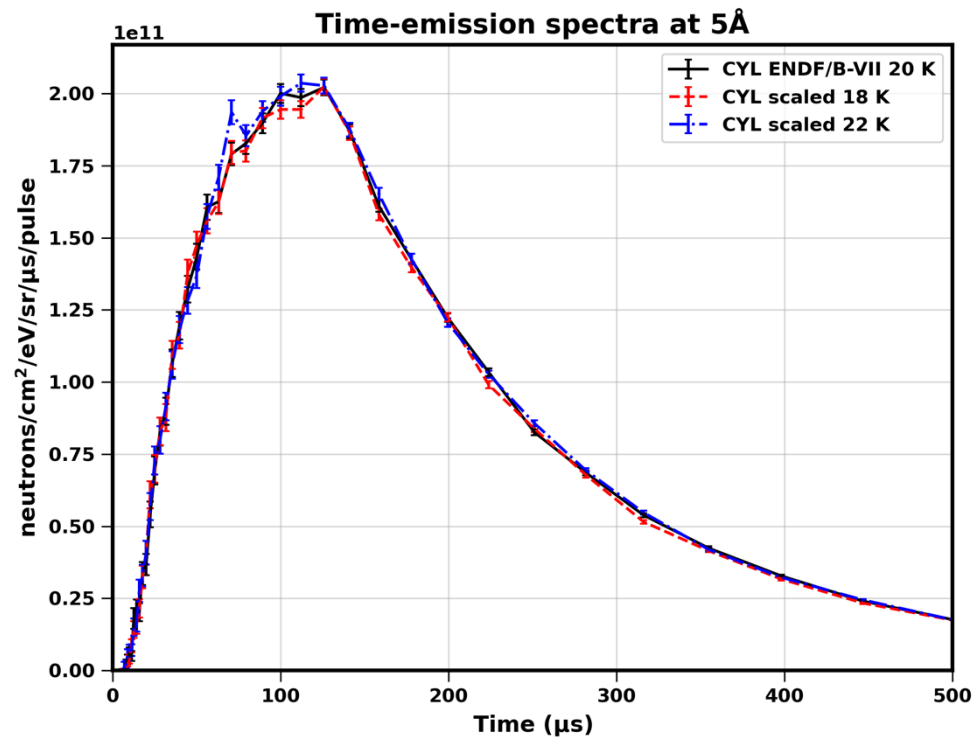

- Max ~1% increase in performance is observed for 2 K rise in temperature

Hydrogen density sensitivity study

- Default hydrogen density is 0.0731 g/cm^3 for cylinder and 0.0721 g/cm^3 for tube moderators
- Sensitivity study was performed in the range of $0.068 - 0.074 \text{ g/cm}^3$

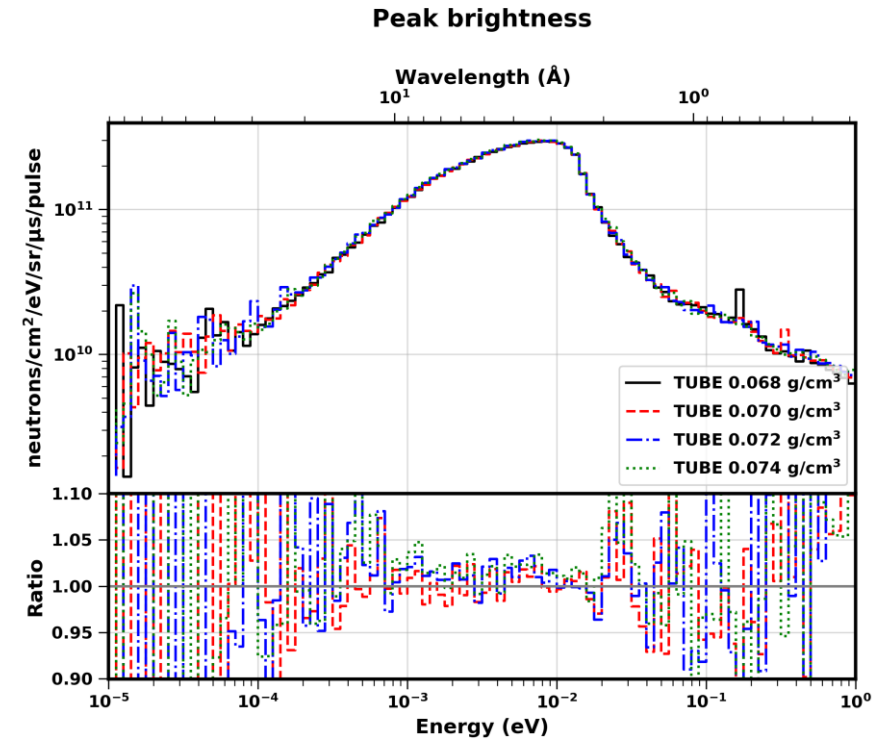
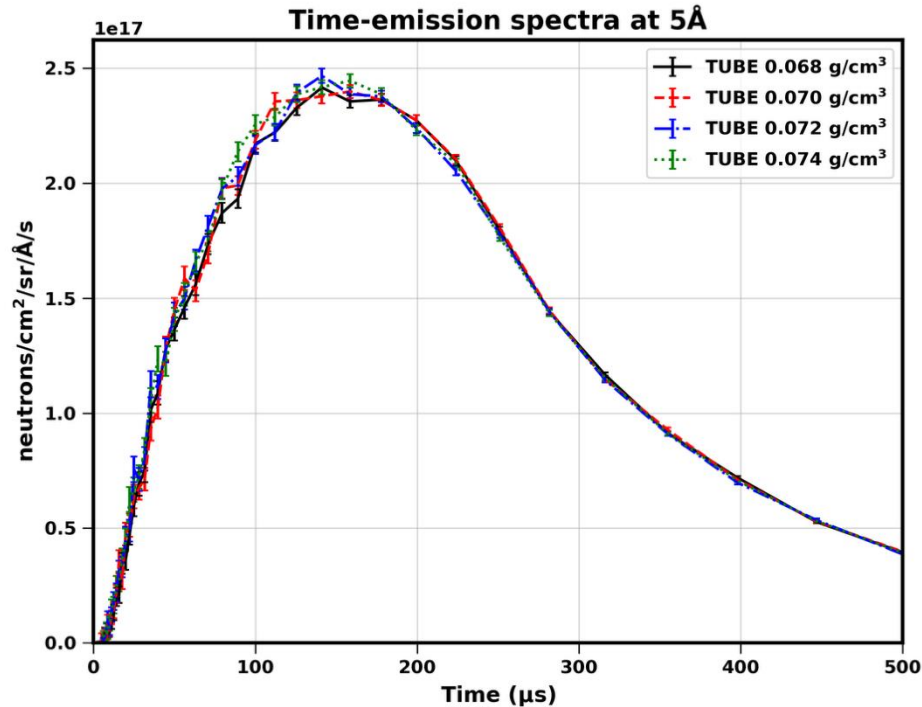

- Max ~1% increase in performance is observed for 0.002 g/cm^3 rise in density

Moderator misalignment study

- Max. misalignment defined as 1.5 mm vertical shift and 1.2° rotation

Maximum misalignment of the moderators

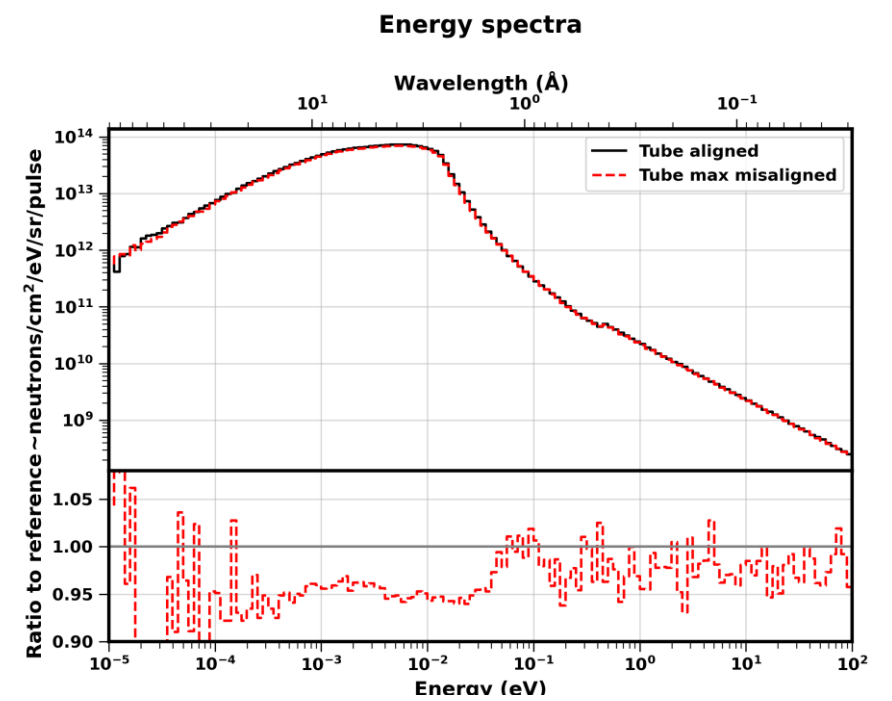
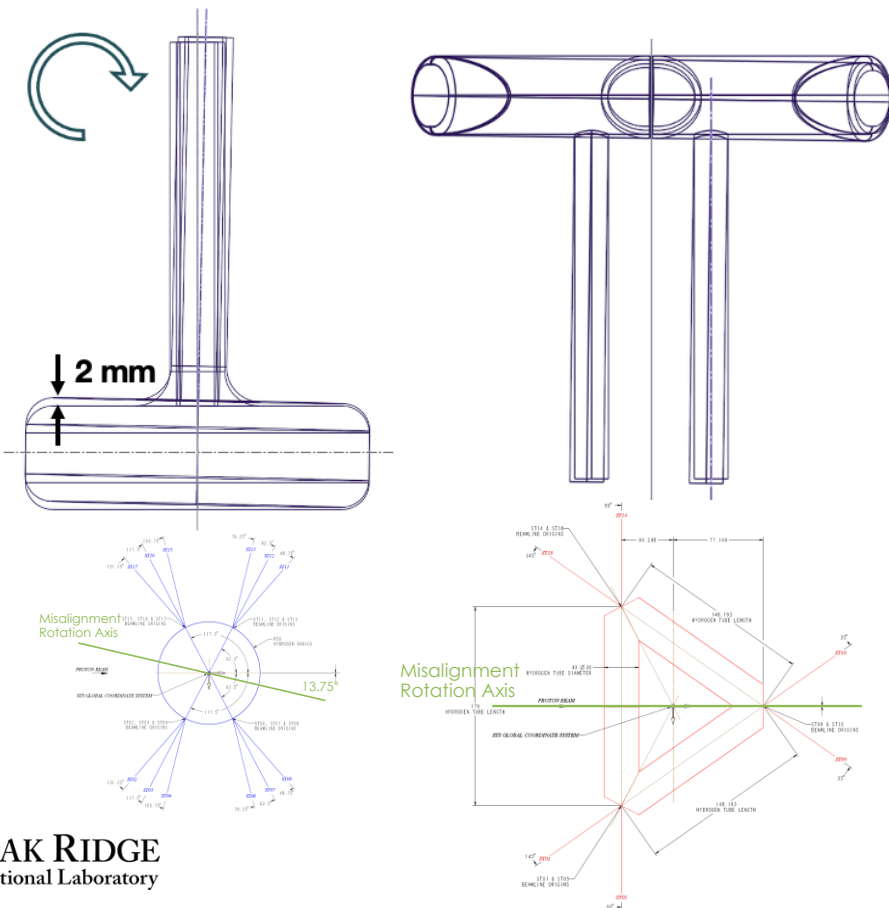

5% at 5Å

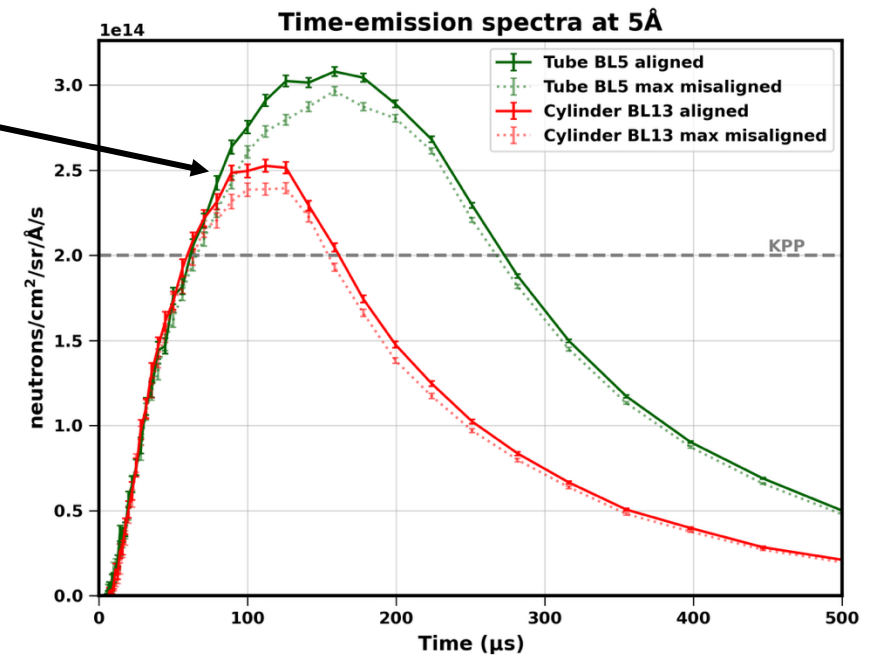

Conclusion

- Wide range of neutronics analyses performed towards the STS final design
- Final design positions STS as the highest peak-brightness source
- Unstructured mesh is the key instrument in the design process and allowed us to develop the final design with increased efficiency and deliver results with higher quality
- Automated coupled multiphysics optimization can be applied during the design process at other neutron sources



Thank you for your attention

Case study I: Target Viewing Periscope (TVP)

- TVP monitors the proton beam profile on the target
- 5 m tall, 10 x 20 cm opening
- Represents a streaming gap
- Need to calculate:
 - Energy deposition (cooling design)
 - Dose rate around the doghouse (protection of electronics)

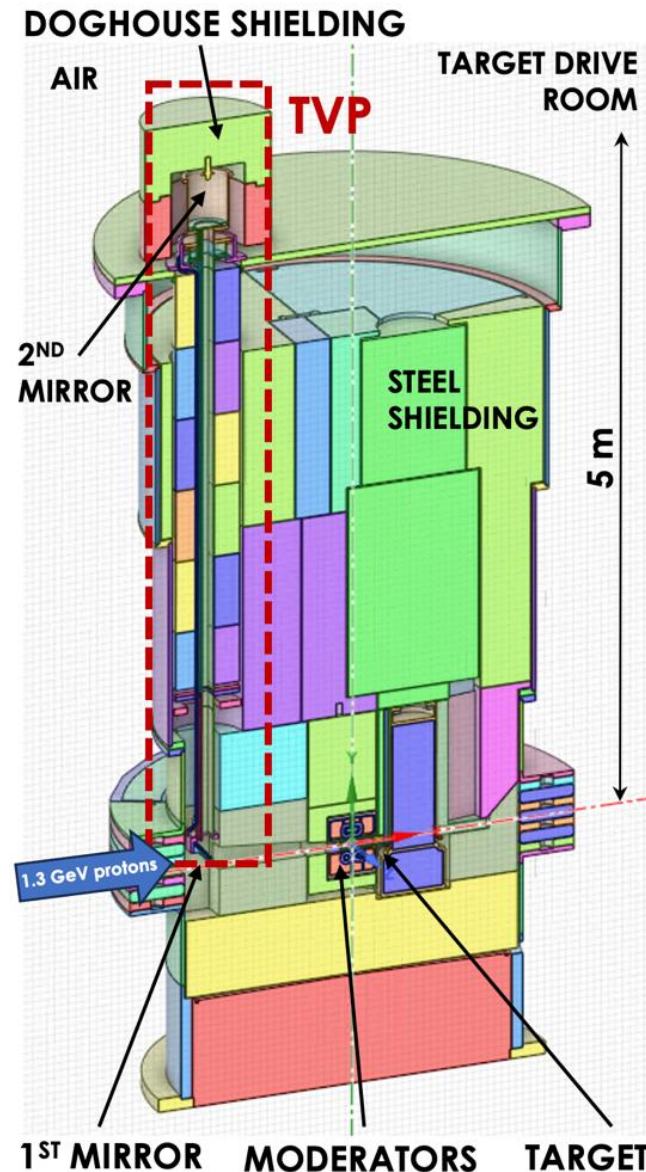

UM FROM PBP MESHER

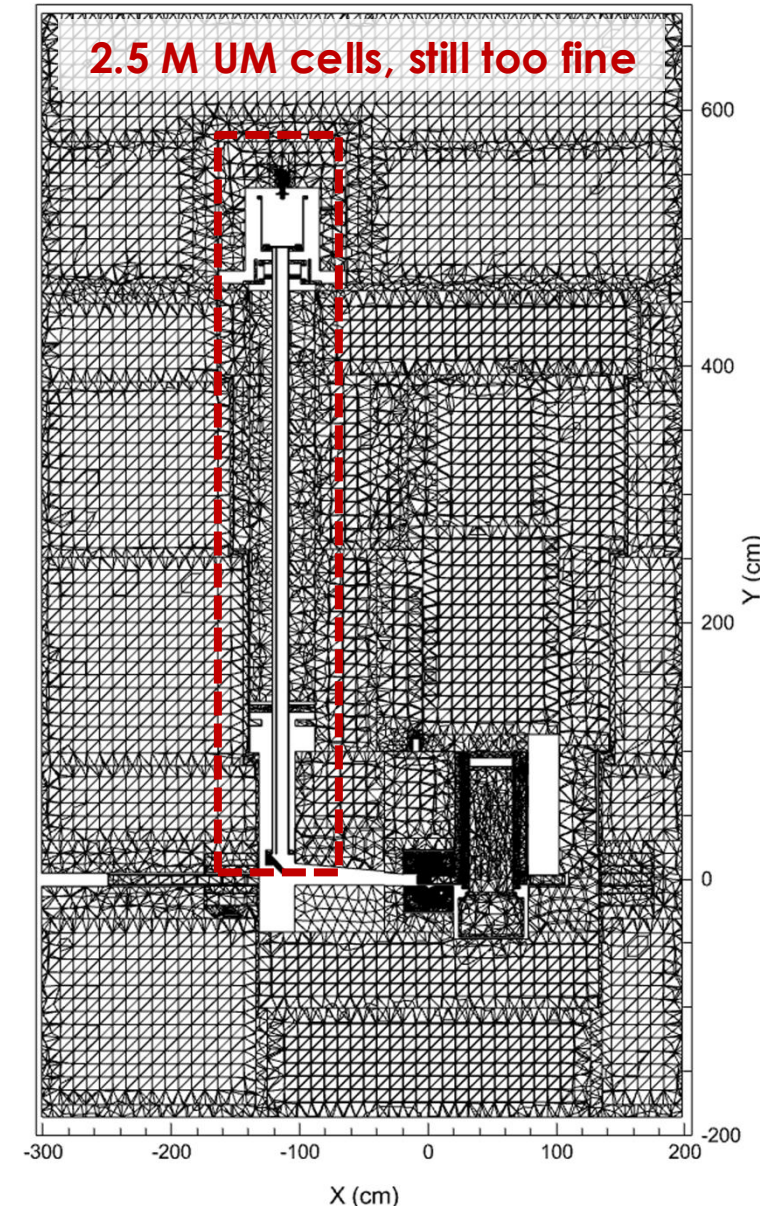

Weight windows (WW) for the TVP analysis

- Energy-dependent deterministic weight windows calculated with Cottonwood for both neutrons and photons
- FW-CADIS starting with a secondary neutron source in the target
- HILO2K materials library used for neutrons up to 1.3 GeV

UM MODEL IN MCNP PLOTTER

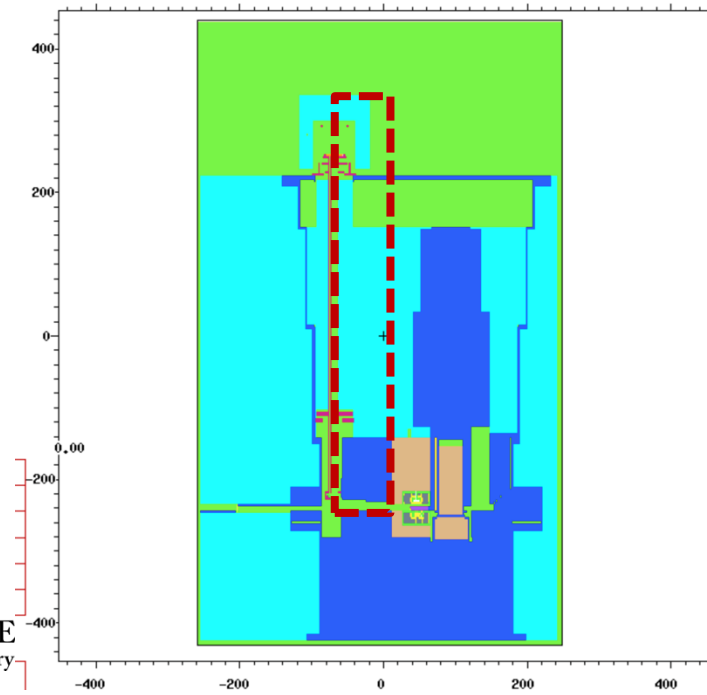

WW FOR 1 MeV NEUTRONS

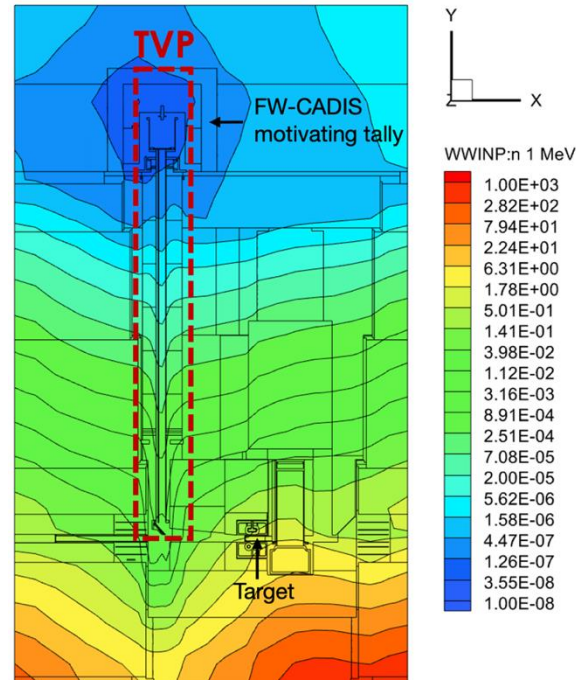

WW FOR 1 MeV PHOTONS

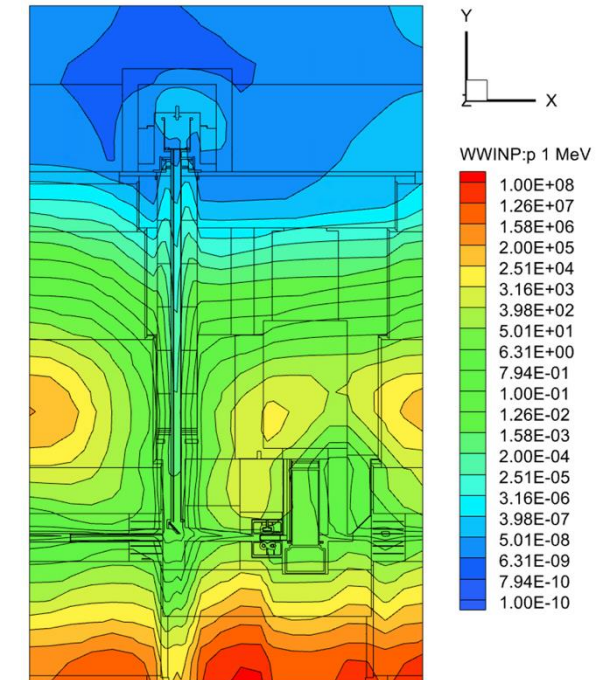

Energy deposition in the TVP

- Energy deposition in the 1st mirror to guide the cooling design:

- Energy deposition in the entire TVP to determine its elongation

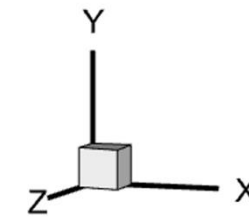
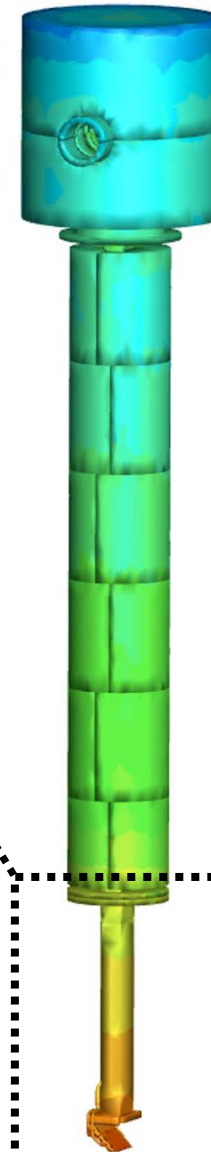
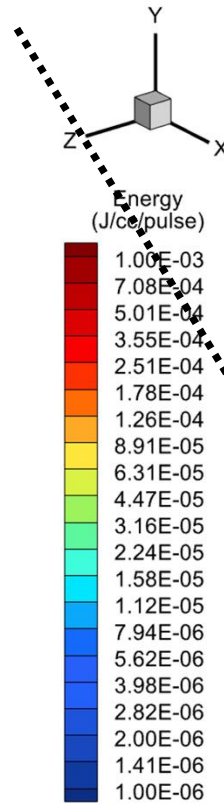
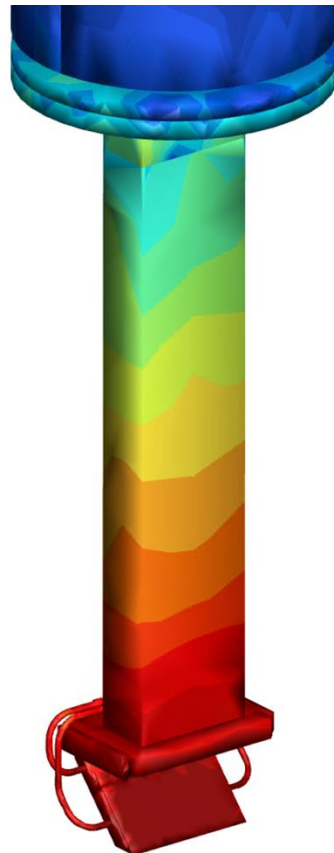
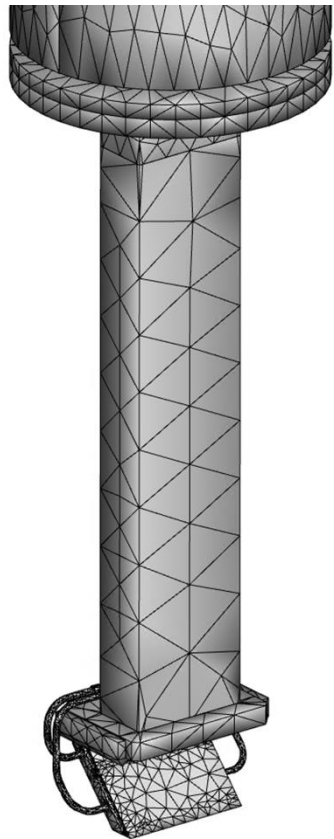

Energy (J/cc/pulse)

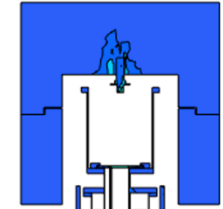
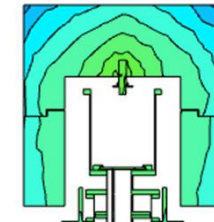
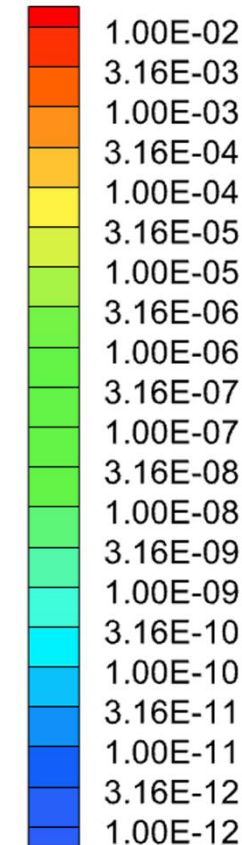

Relative Error

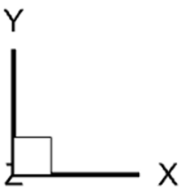
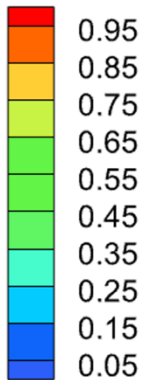

Total prompt dose rate around the TVP doghouse

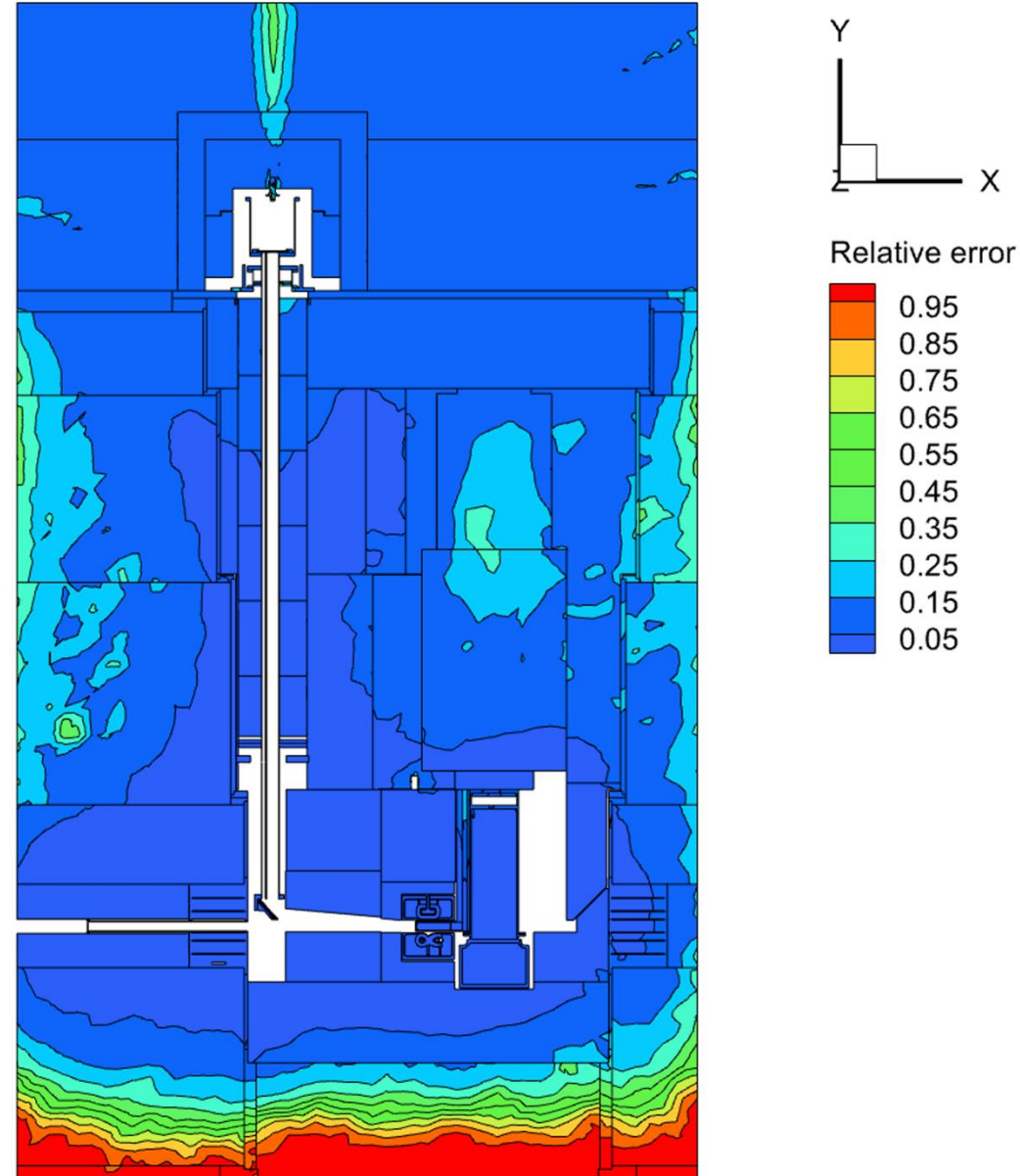
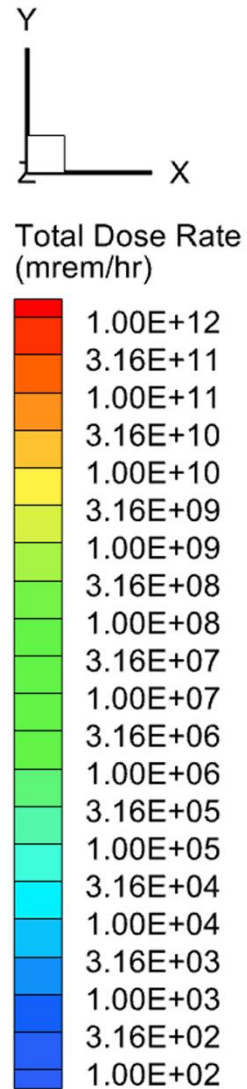
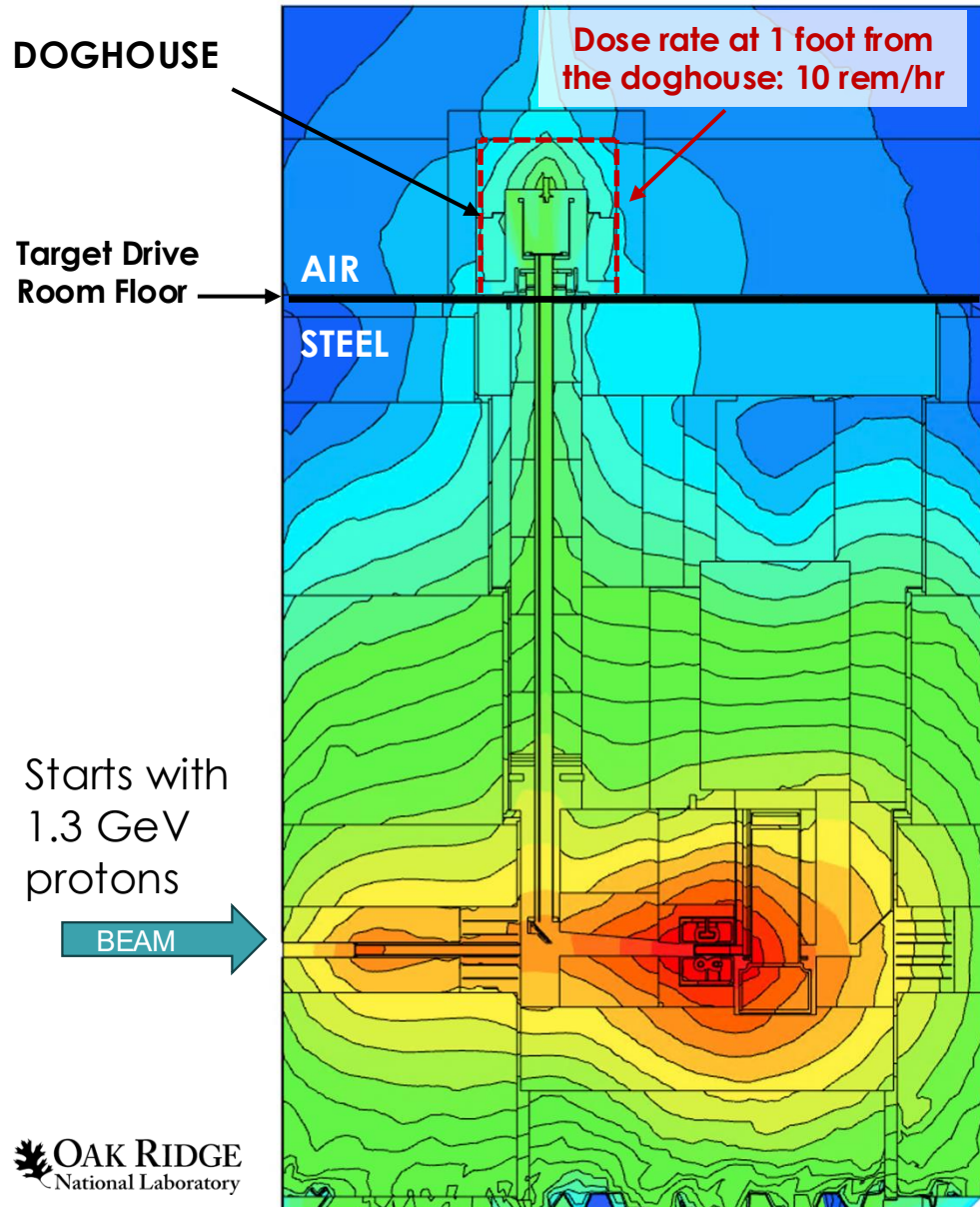

Case study II: Target Shaft

- Energy deposition

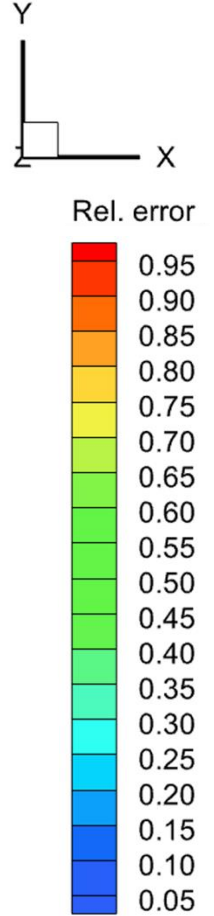
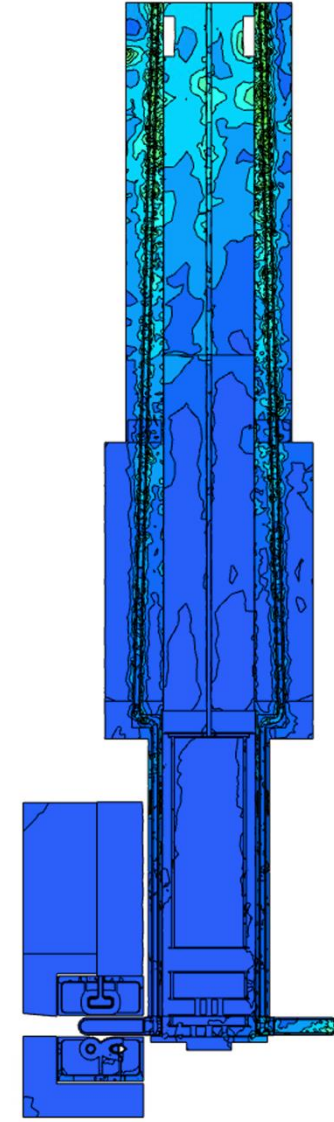
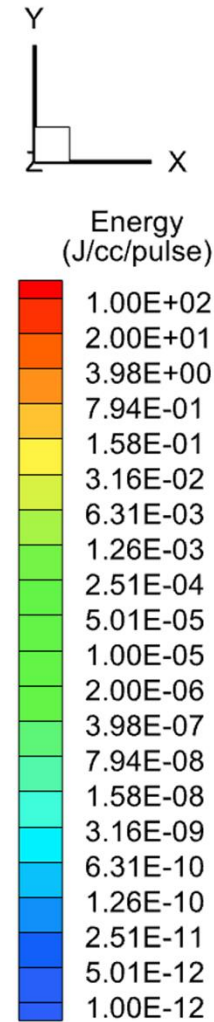
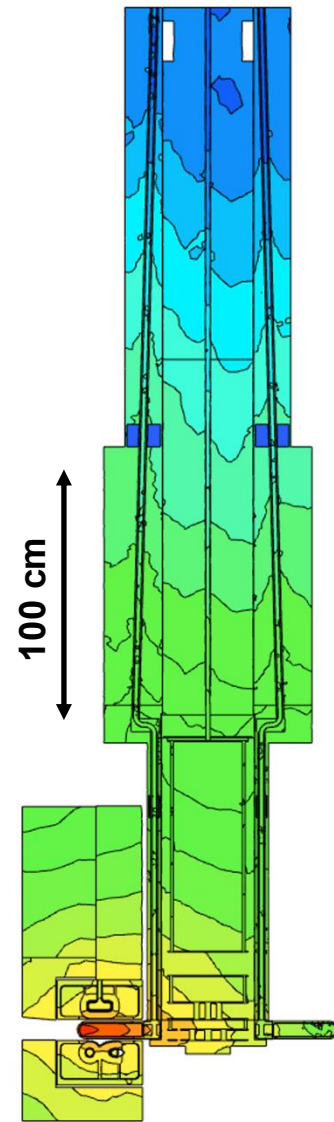
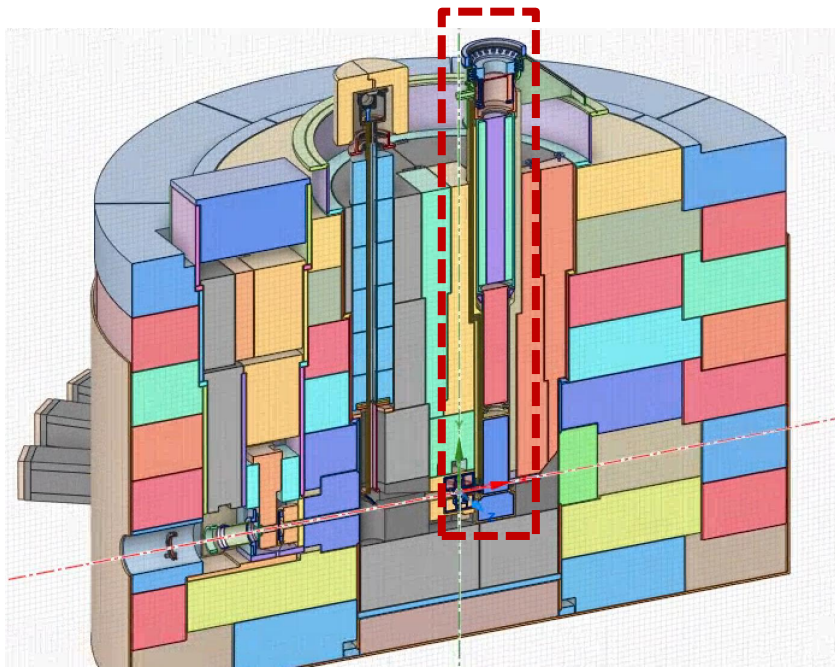

Cooling pipes and narrow streaming gaps

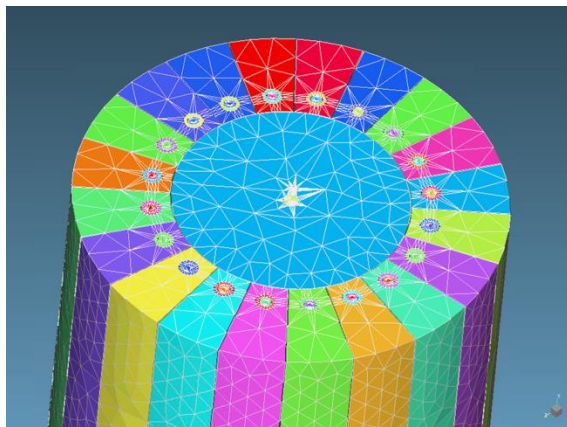

Starts with 1.3 GeV protons

Silicon production in the MRA

- Silicon production via thermal neutron ($E < 0.414$ eV) capture in aluminum
- $^{27}\text{Al} + n_{\text{th}} \rightarrow ^{28}\text{Al} + \gamma$; $^{28}\text{Al} \rightarrow ^{28}\text{Si} + \beta^-$
- Max thermal flux is 0.095 n/cm²/proton or $5.75\text{E}+21$ n/cm²/year, which is $3.73\text{E}+22$ n/cm²/6.5 years (lifetime limit due to dpa), which is below the dose limit* of $6.0\text{E}+22$ n/cm²

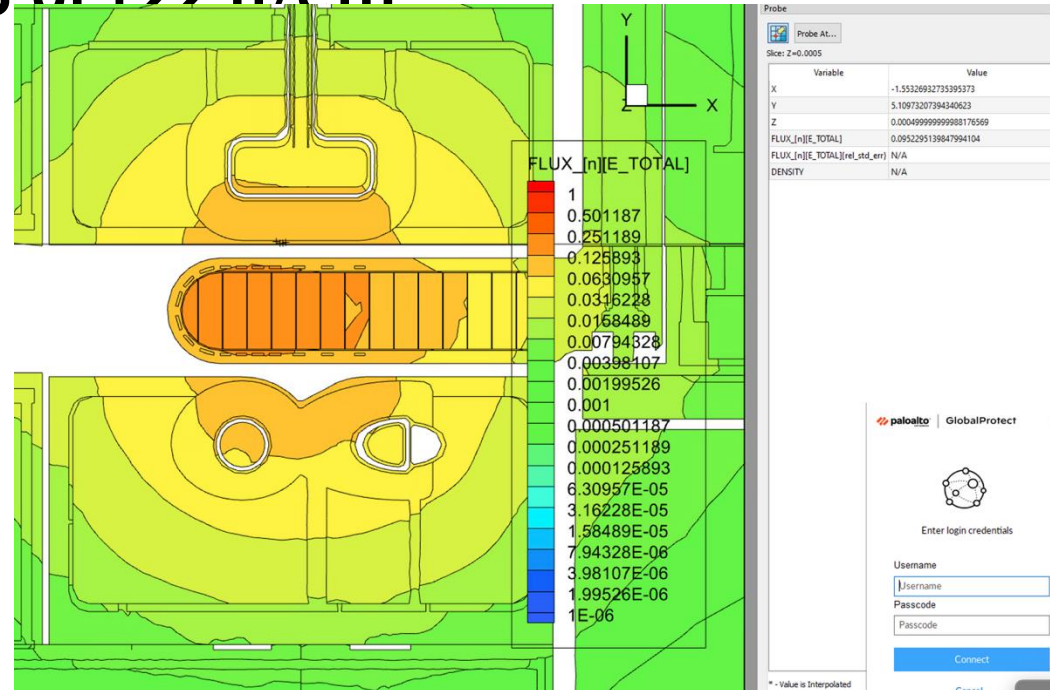

Dose limit from Y.J. Lee et al.,
Materials Handbook: STS Project