



Fermi chopper developed at CSNS

Weiliang Cai

caiwl@ihep.ac.cn

China Spallation Neutron Source(CSNS)

Dongguan branch, Institute of High Energy Physics, Chinese Academy of Sciences (CAS)



- 1. Background**
- 2. Current Status**
- 3. Upgrade Concepts**
- 4. Summary**

CSNS Neutron Instruments

BL1: Small angle neutron scattering

BL2: Multifunction reflectometer

BL3: Liquid neutron reflectometer

BL4: Cold Neutron Inelastic Spectrometer

BL5: High energy Inelastic spectrometer

BL6: Indirect geometry molecular vibration spectrometer

BL7: reserved

BL8A: Neutron Technology Development Station

BL8: The engineering materials neutron diffractometer

BL9: High resolution neutron diffractometer

BL10: Neutron back scattering spectrometer

BL10A: reserved

■ **DWM**

■ **E_i Range**

✓ 10meV – 1500meV

■ **Energy Resolution**

✓ dE/E_i : 3% in best case

■ **Operation Mode**

✓ Basic mode: Single E_i

✓ Compatible to repetition rate multiplication (rrm) mode

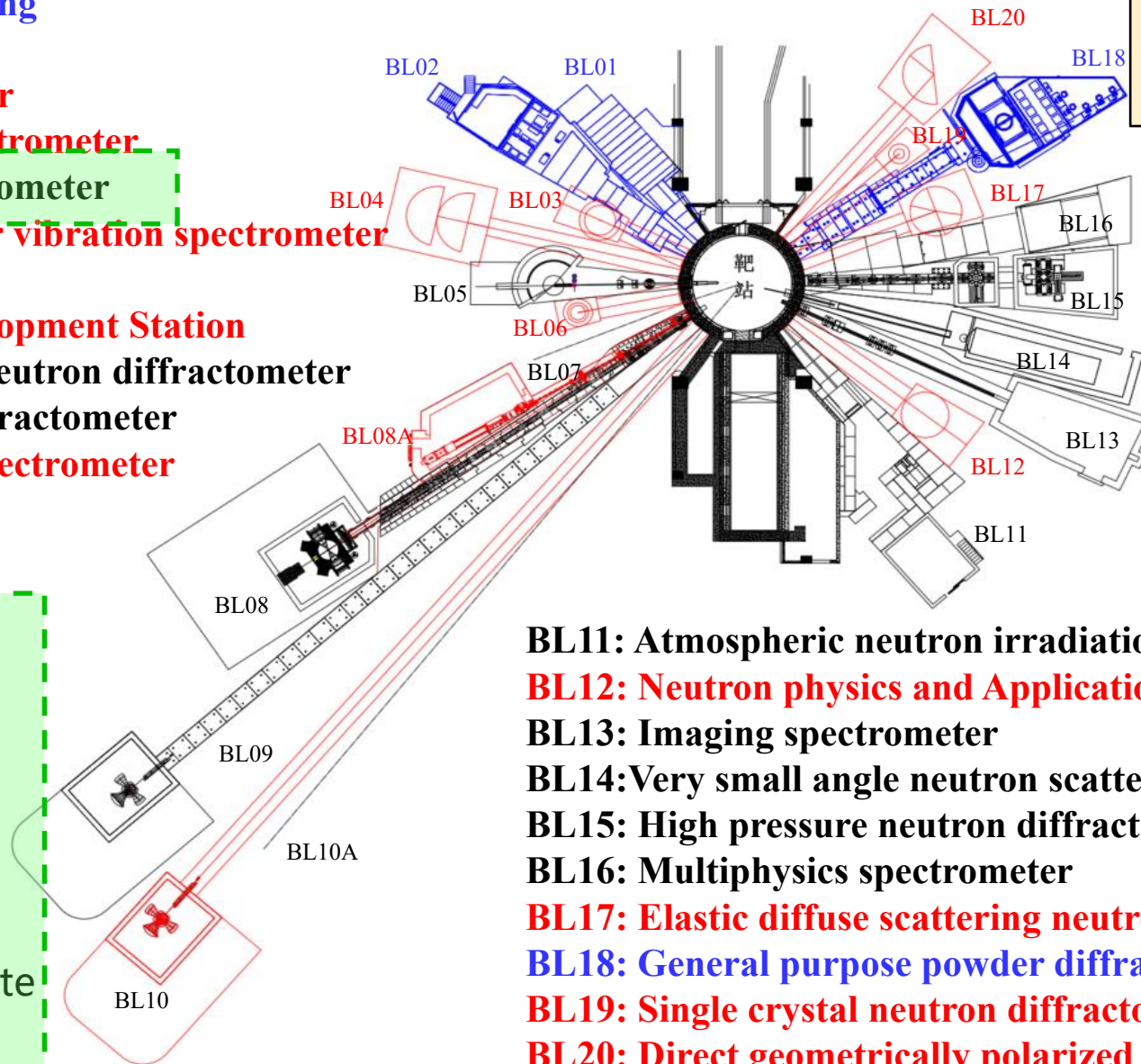

CSNS-I: 2011~2018 Blue

Local cooperation: 2018~2024 Black

CSNS-II: 2024~2029 Red

BL11: Atmospheric neutron irradiation spectrometer

BL12: Neutron physics and Application spectrometer

BL13: Imaging spectrometer

BL14: Very small angle neutron scattering

BL15: High pressure neutron diffractometer

BL16: Multiphysics spectrometer

BL17: Elastic diffuse scattering neutron spectrometer

BL18: General purpose powder diffraction spectrometer

BL19: Single crystal neutron diffractometer

BL20: Direct geometrically polarized inelastic spectrometer

High Energy Inelastic Spectrometer

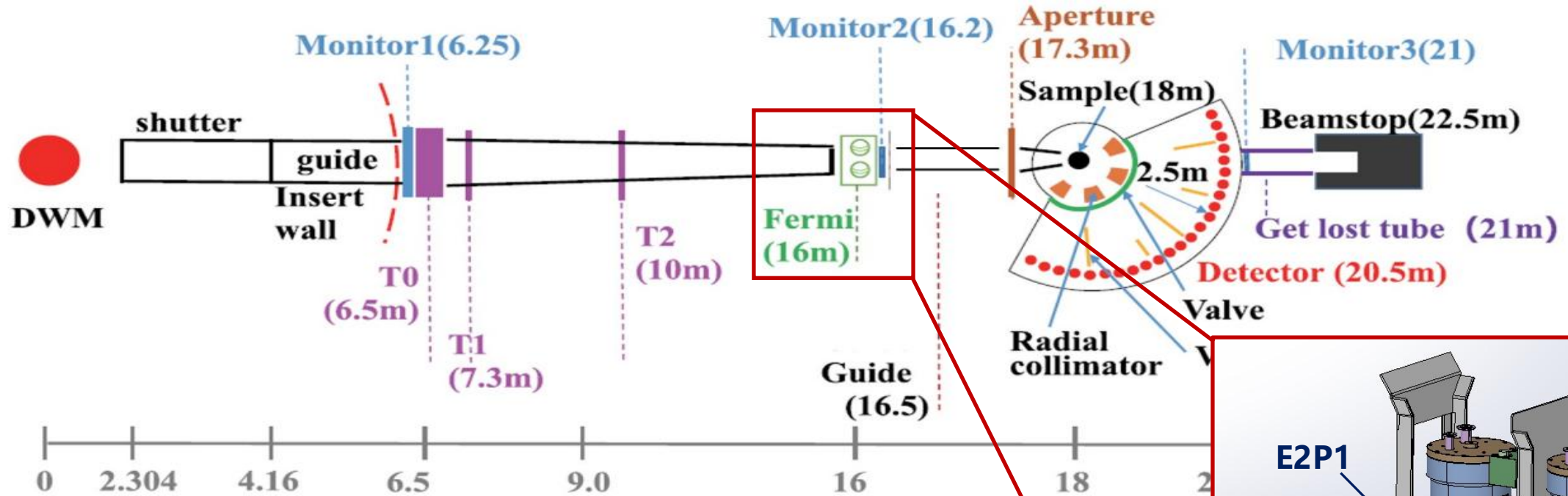

Chopper ID	Position /m	Beam size/mm	Speed/Hz	Channel length/mm	Channel width/mm	Radius/m	Channel material	Absorber material	Absorber thickness/ μ m
E1	16	57 × 57	600Hz	17.55	0.27	straight	Si	^{10}B	41
E2P1	16	57 × 57		27	0.44	arc-0.37	Al	^{10}B	43
E2P2	16	57 × 57		11.5	0.23	straight	Si	Gd	22

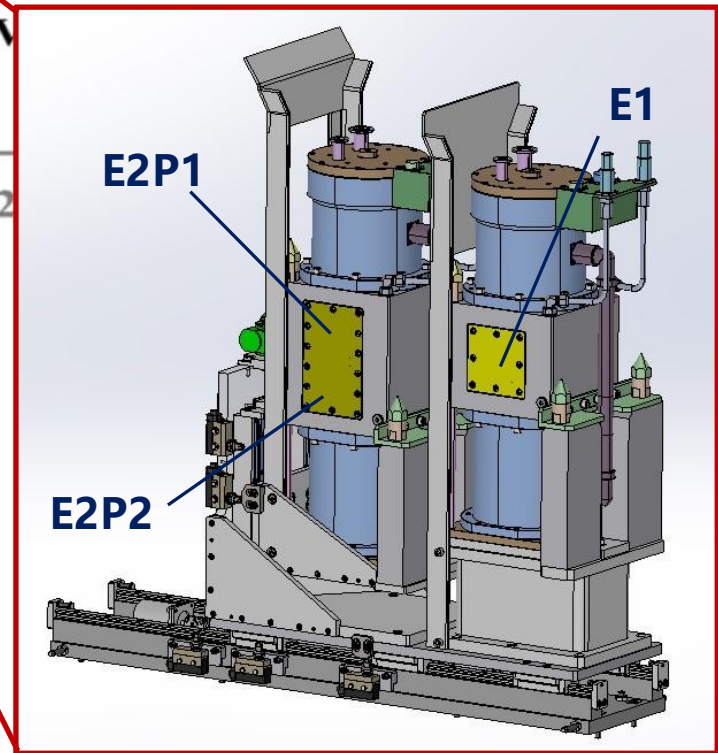



1. Background
2. **Current Status**
3. Upgrade Concepts
4. Summary

First-Generation Fermi Chopper

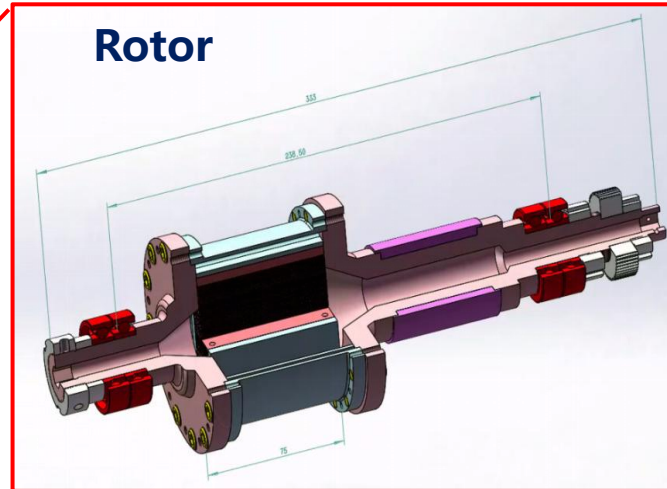
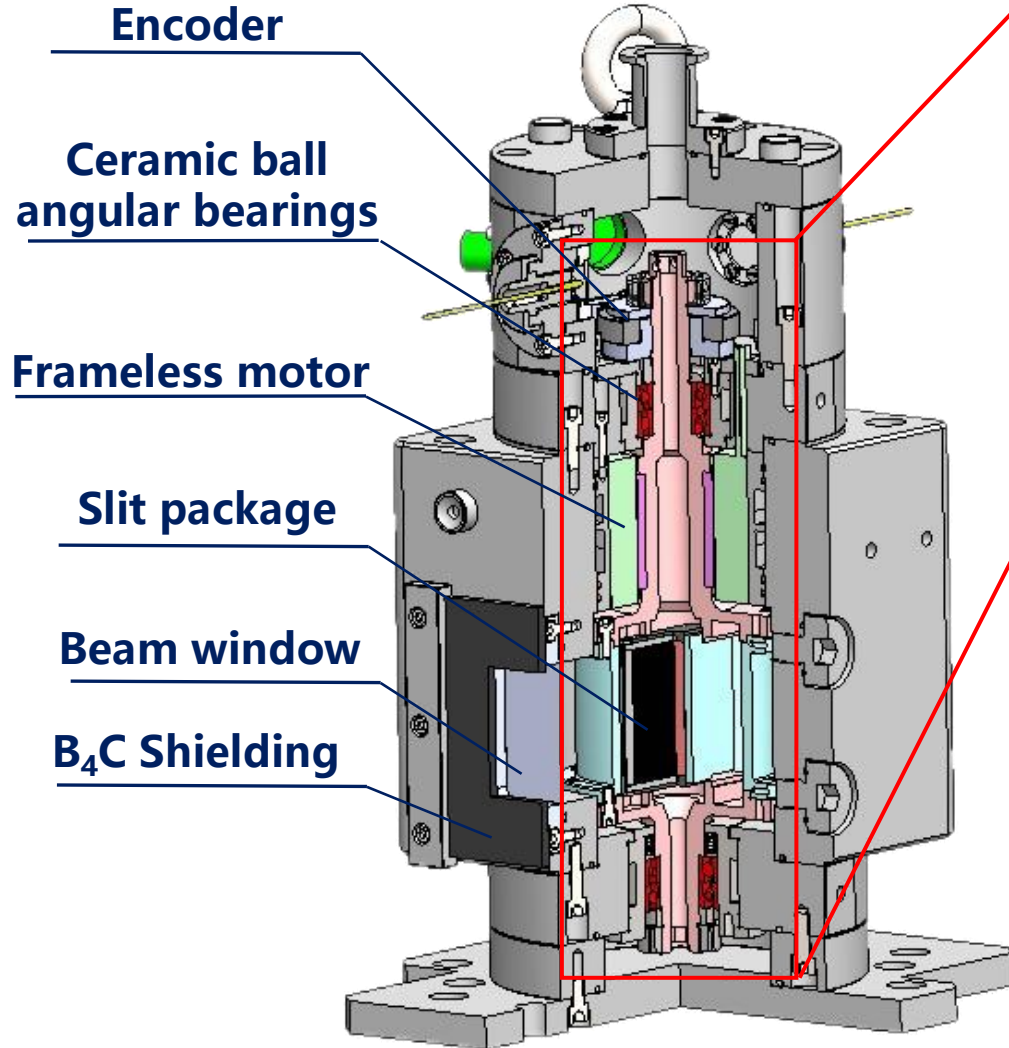

Three section shaft(333mm in total length).

The weight of rotor is 5kg(slit package is 0.8kg)

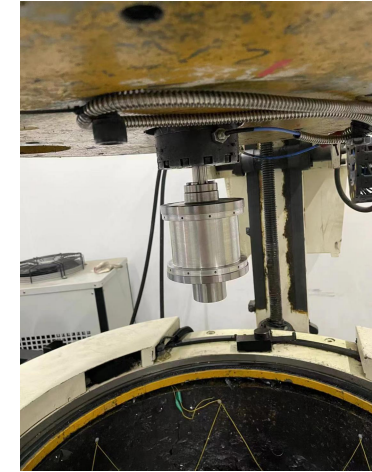

120% over-speed test

Aluminum Frame

Slit package
(22 μ m Gadolinium foil,
0.23 mm Silicon)

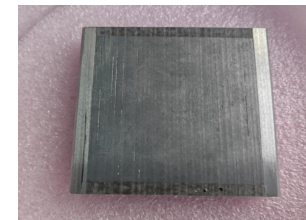

Interference fit
by heating

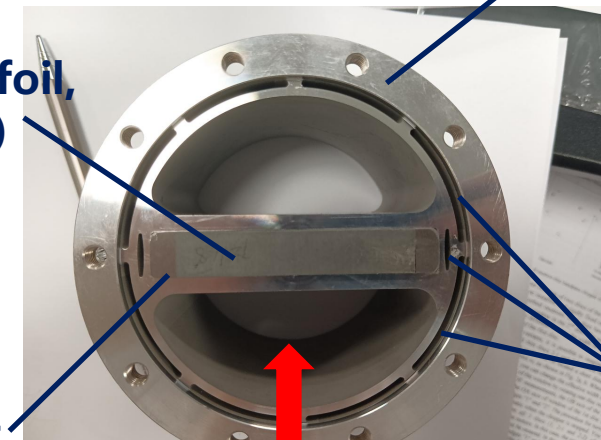

Neutron incidence

Operation performance

- Installed and used in BL05
- Running for 3 years with stable performance.
- Vibration: 0.4mm/s@600Hz
- Performance:
 - FWHM: 50% wider than the theoretical value
 - Transmittance: 15%~25%

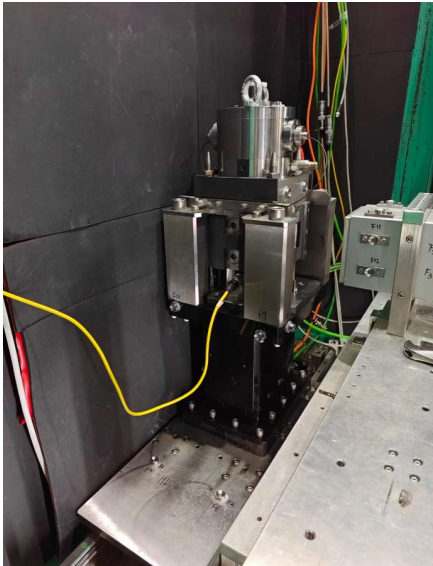

Install in BL05

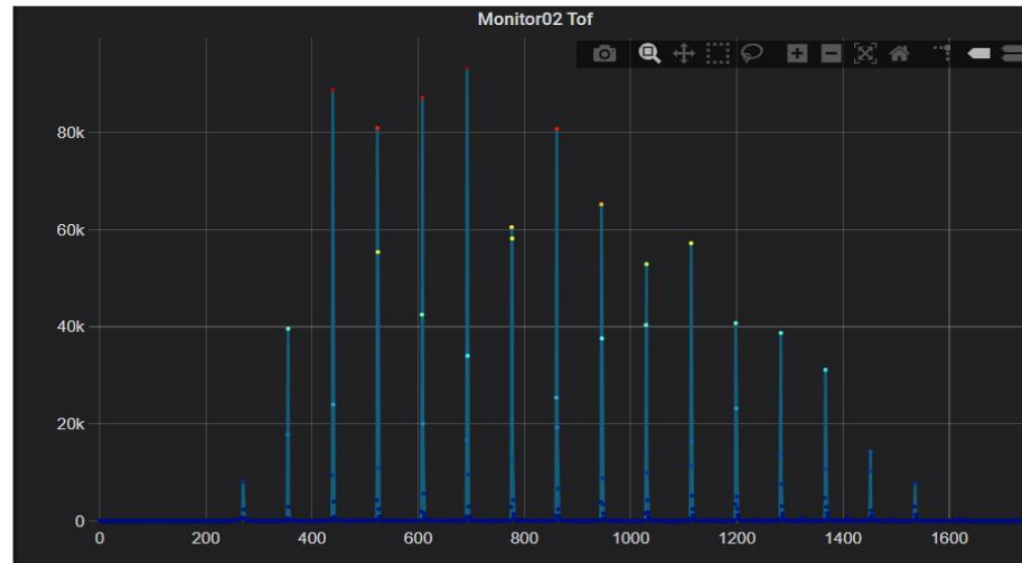

Beam Test Result(600Hz)



- 1. Background**
- 2. Current Status**
- 3. Upgrade Concepts**
- 4. Summary**

Existing issues

- Gadolinium absorbing material cannot meet the requirements of the high-energy inelastic spectrometer.
- Transmission efficiency is lower than the theoretically calculated value.
- Rotor heating and deformation

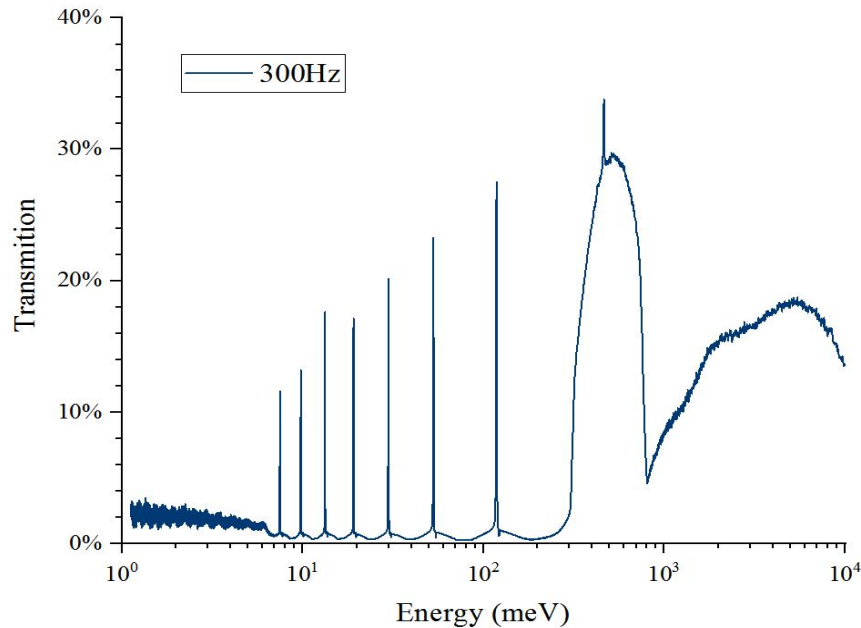

Unavailable for high-energy applications

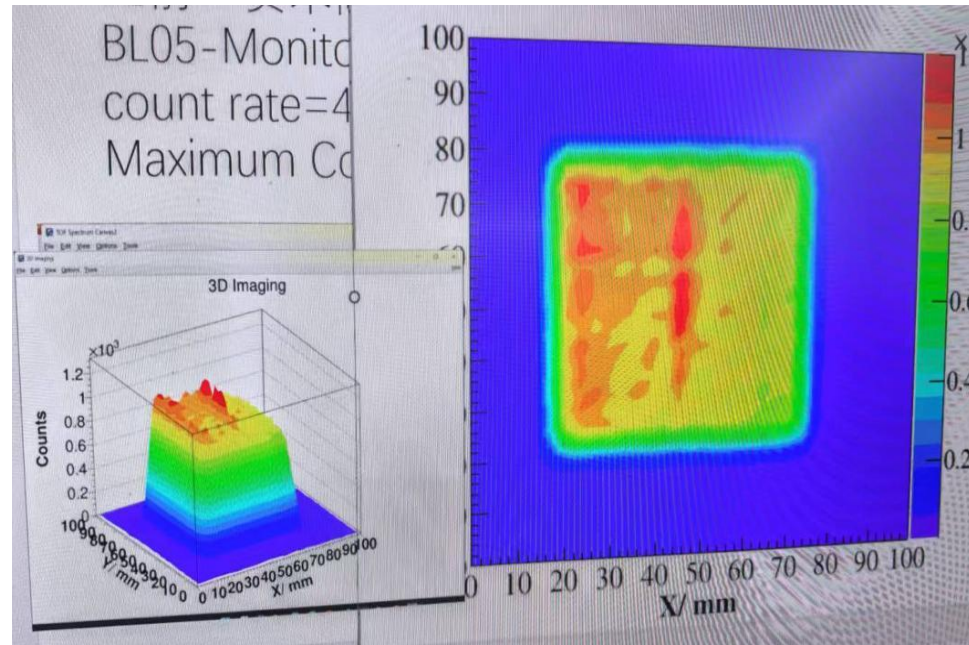

Some central mechanical deformation at 600 Hz

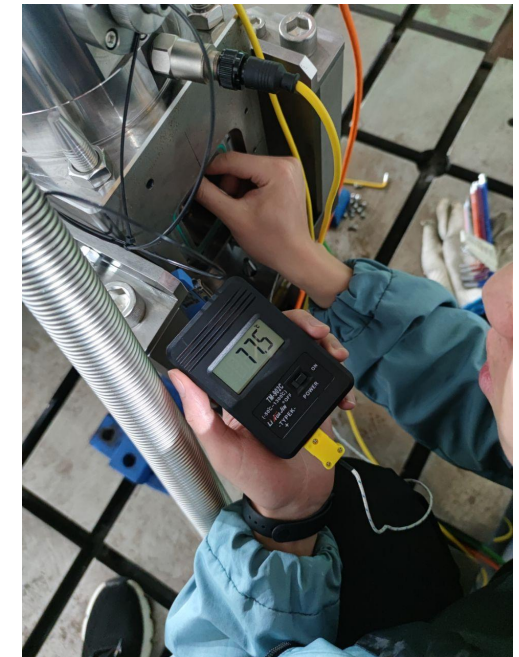

Thermal generation in the rotor

Upgrade Concepts

- Switch to ^{10}B -enriched boron carbide as the absorbing material

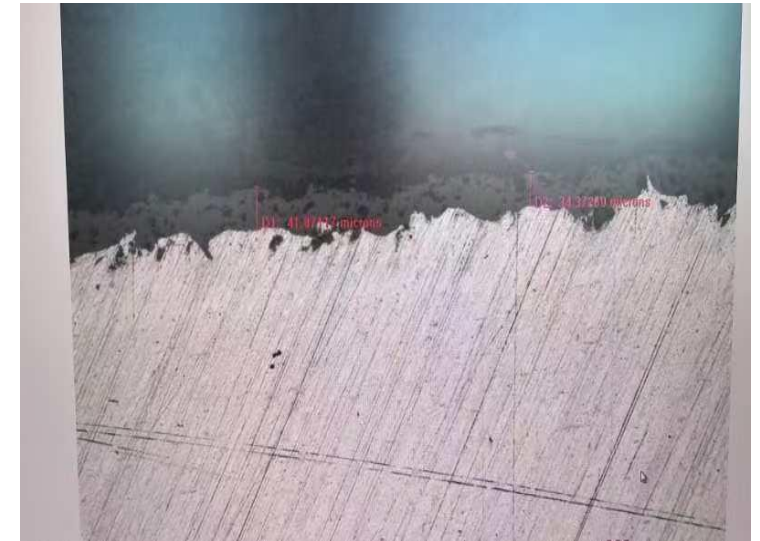

Plasma spraying (B_4C on Si)

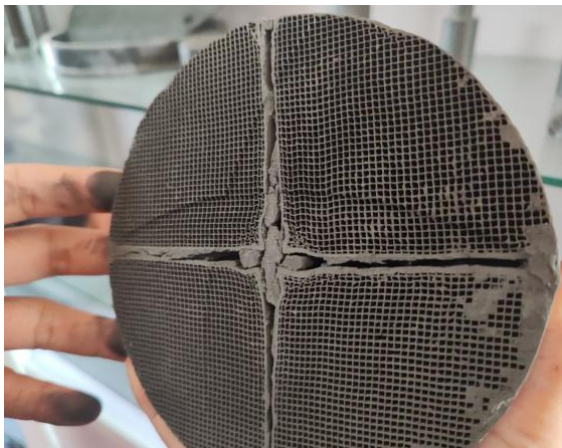

Sintered boron carbide



Laser cutting

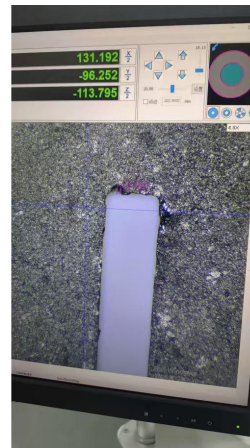

- Remove the transmission layer material to achieve neutron flux gain

Upgrade Concepts

- Use carbon fiber instead of aluminum alloy to suppress rotor deformation an attempt to increase rotational speed
- Adopt liquid metal bearing technology to enhance heat dissipation capability

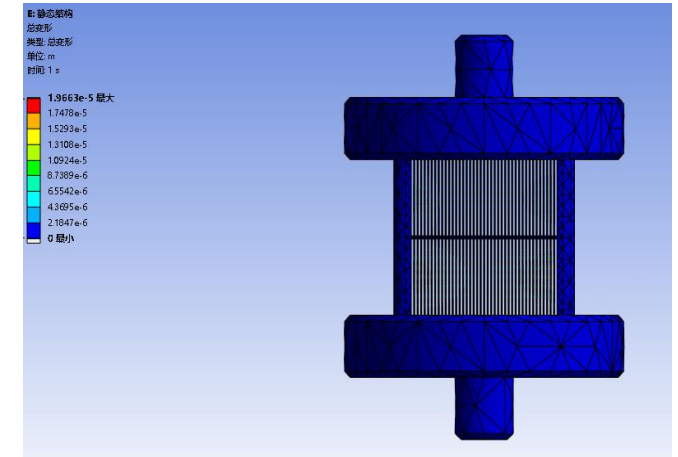

Slit package without transmission layer



CT tube



Liquid metal(Ga-In-Sn alloy)

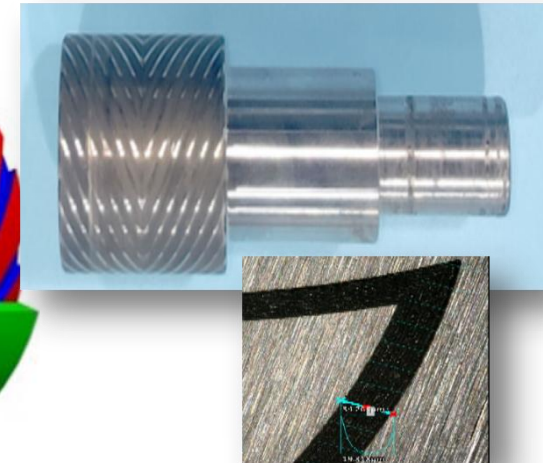
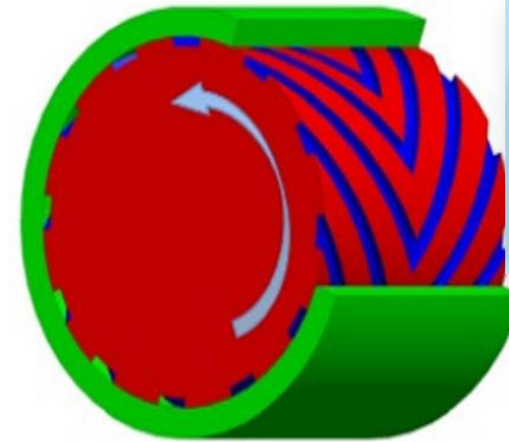

Liquid metal bearing design



- 1. Background**
- 2. Current Status**
- 3. Upgrade Concepts**
- 4. Summary**

Summary

- New development of fermi chopper is ongoing at CSNS
- Explore new methods for monochromatic selection
- Chopper team in CSNS

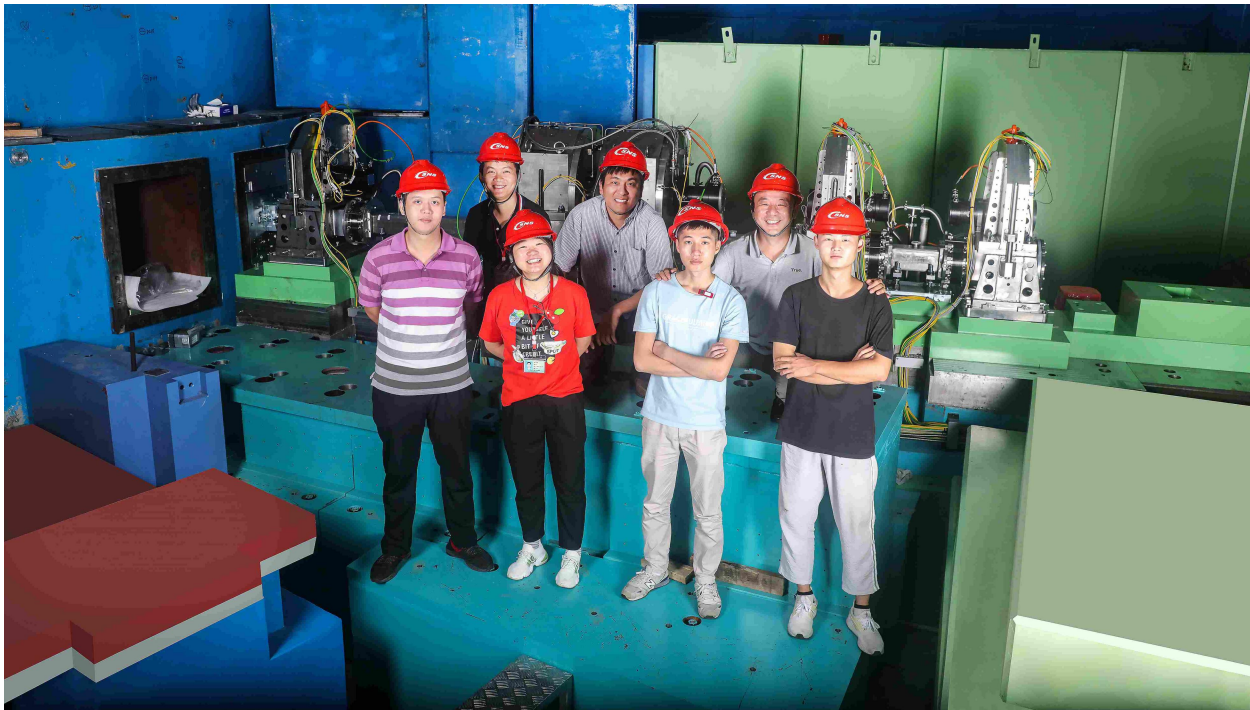

CSNS Chopper Team

Number and type distribution of neutron choppers

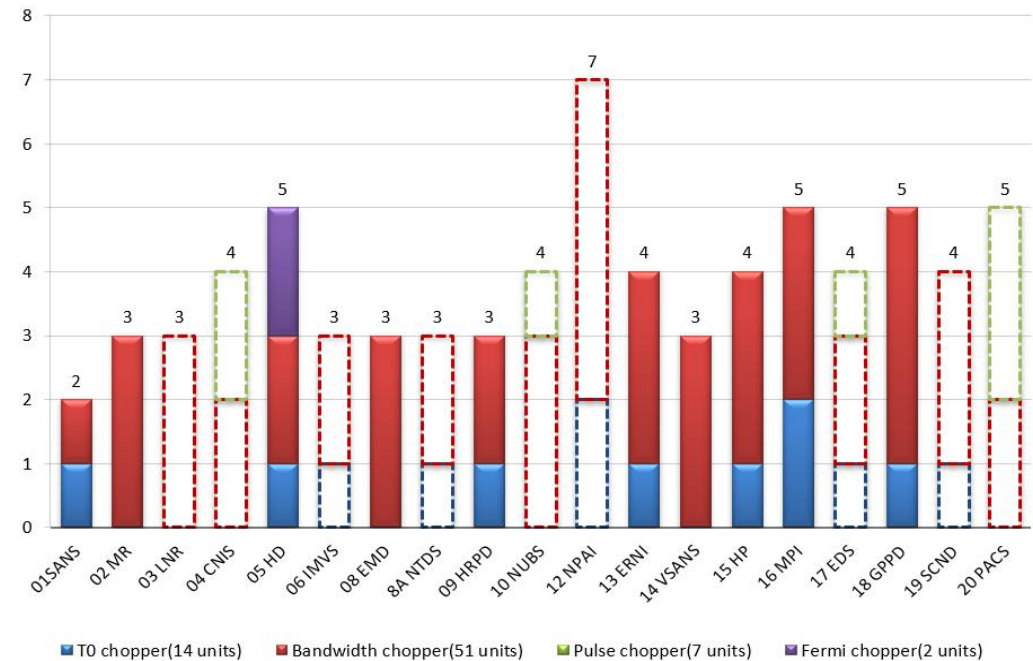

Thank you for your listening! ! !