



EUROPEAN
SPALLATION
SOURCE



JÜLICH
Forschungszentrum



MAGiC instrument update

April 2026

- Moritz Braun accepted the Instrument Operation Engineer position
- New design engineer starts on May 4th

Bunker

Bunker components

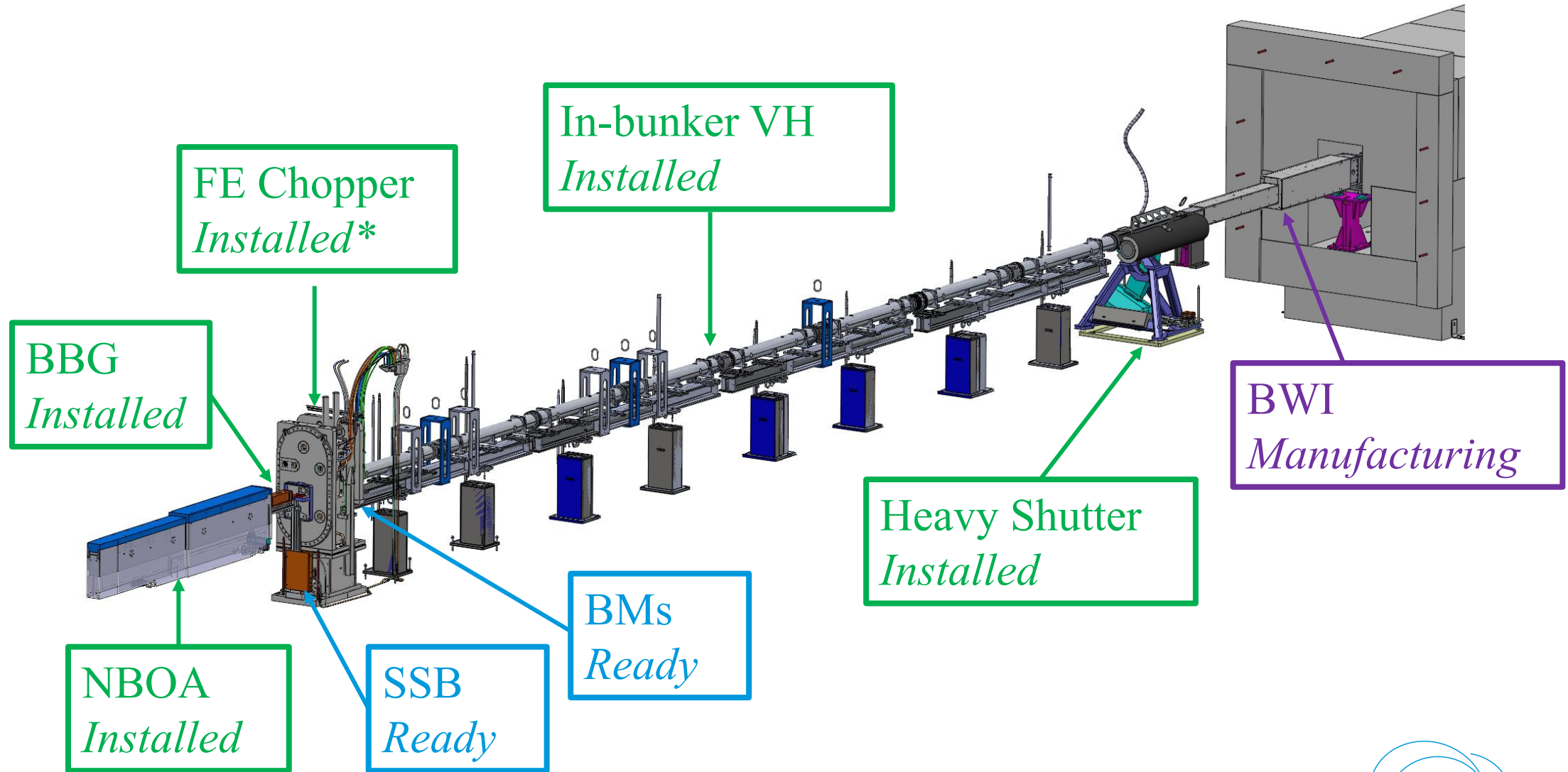

Solid State Bender (SSB)

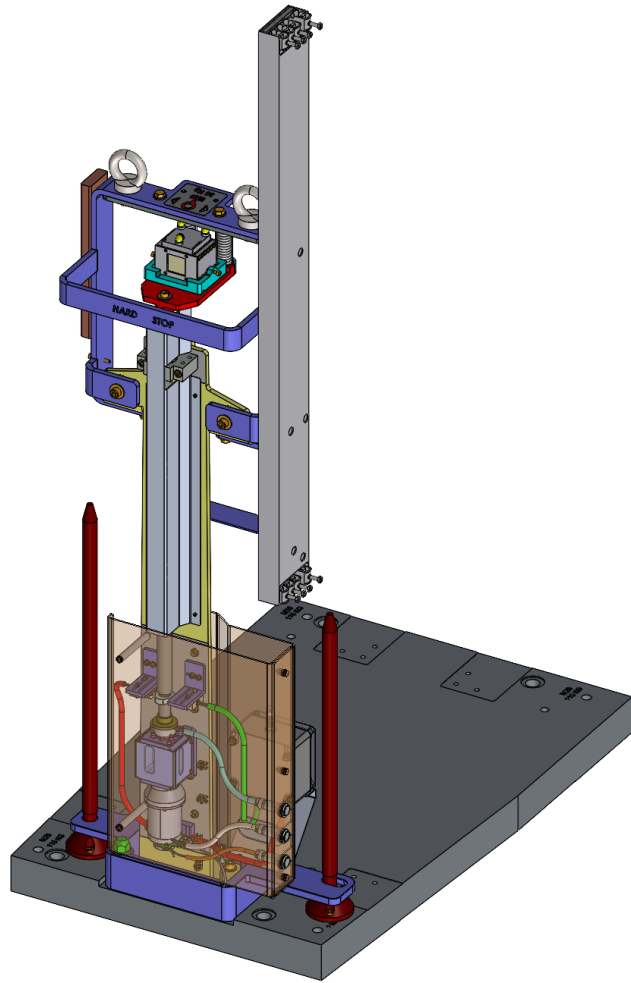

FE Chopper

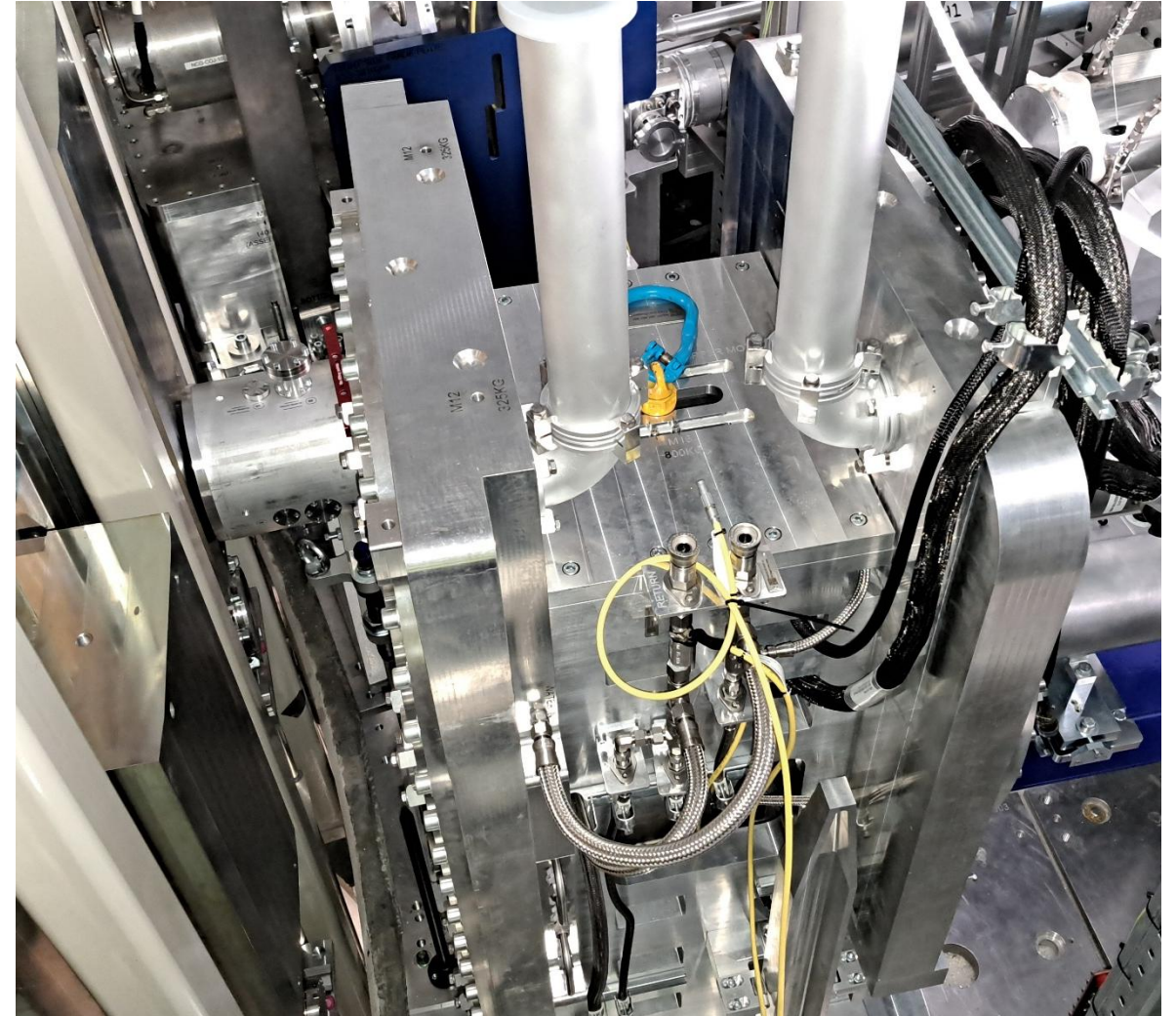

In-bunker Vacuum Housing



In-bunker Vacuum Housing

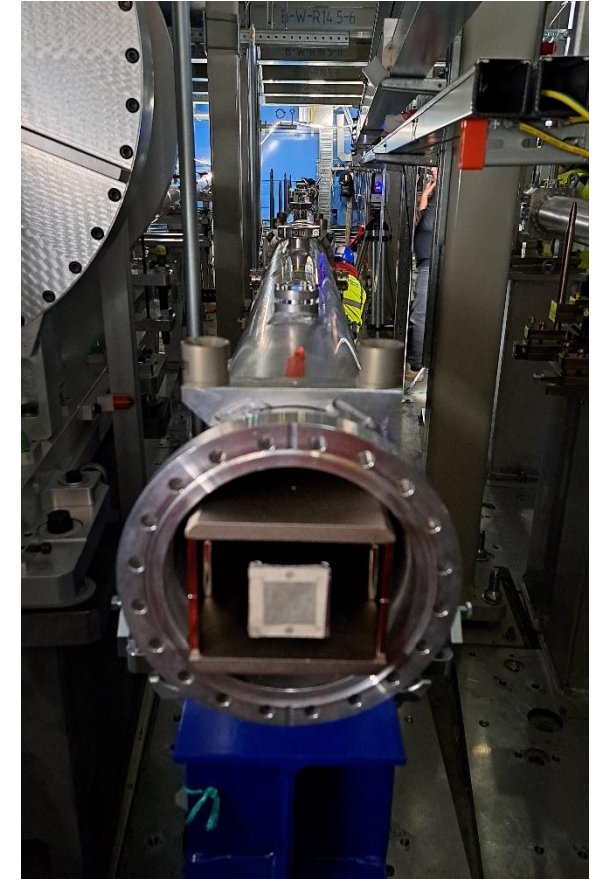
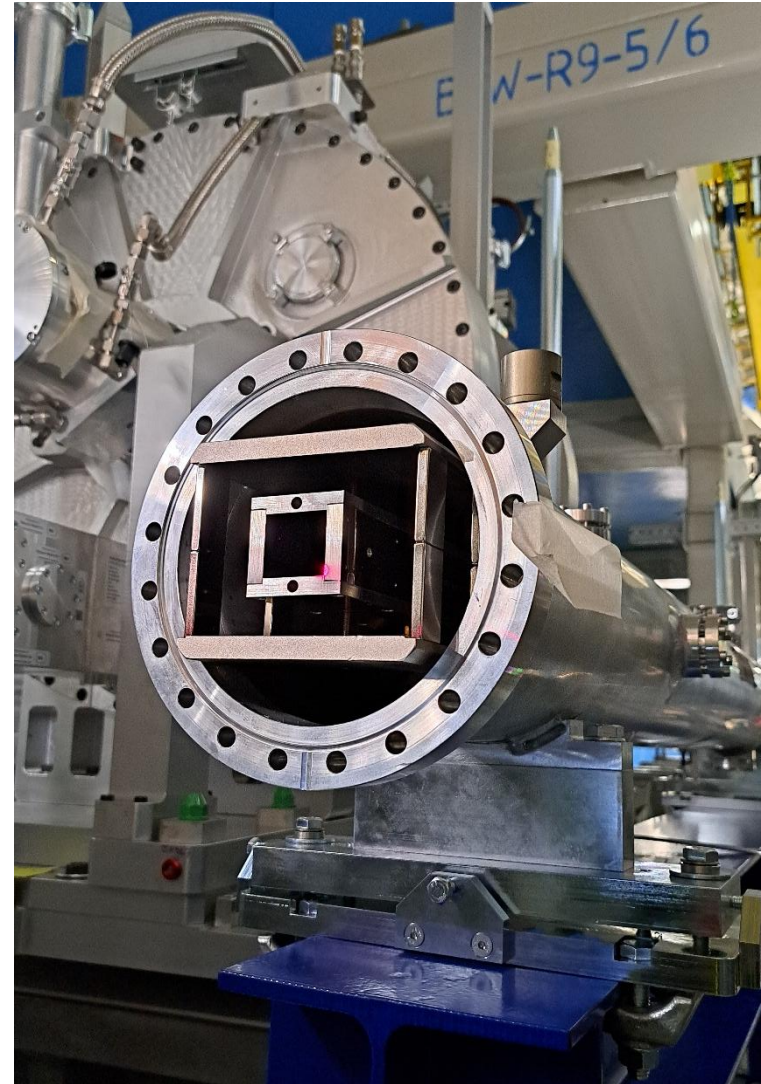

Bunker Wall Insert



The installation in June

Out-of-Bunker Neutron Optics and Conditioning Systems

D03/E02 components

160m-long neutron guide
Ready

OoB VH, Sect. 4
Designed

Adiabatic Spin-Flipper
Being designed

OoB VH, Sect. 2
Designed

Thermal neutron polarizer
Designed

OoB VH, Sect. 1
Manufacturing

Band Chopper
*Installed**

Neutron guide shielding
Ready

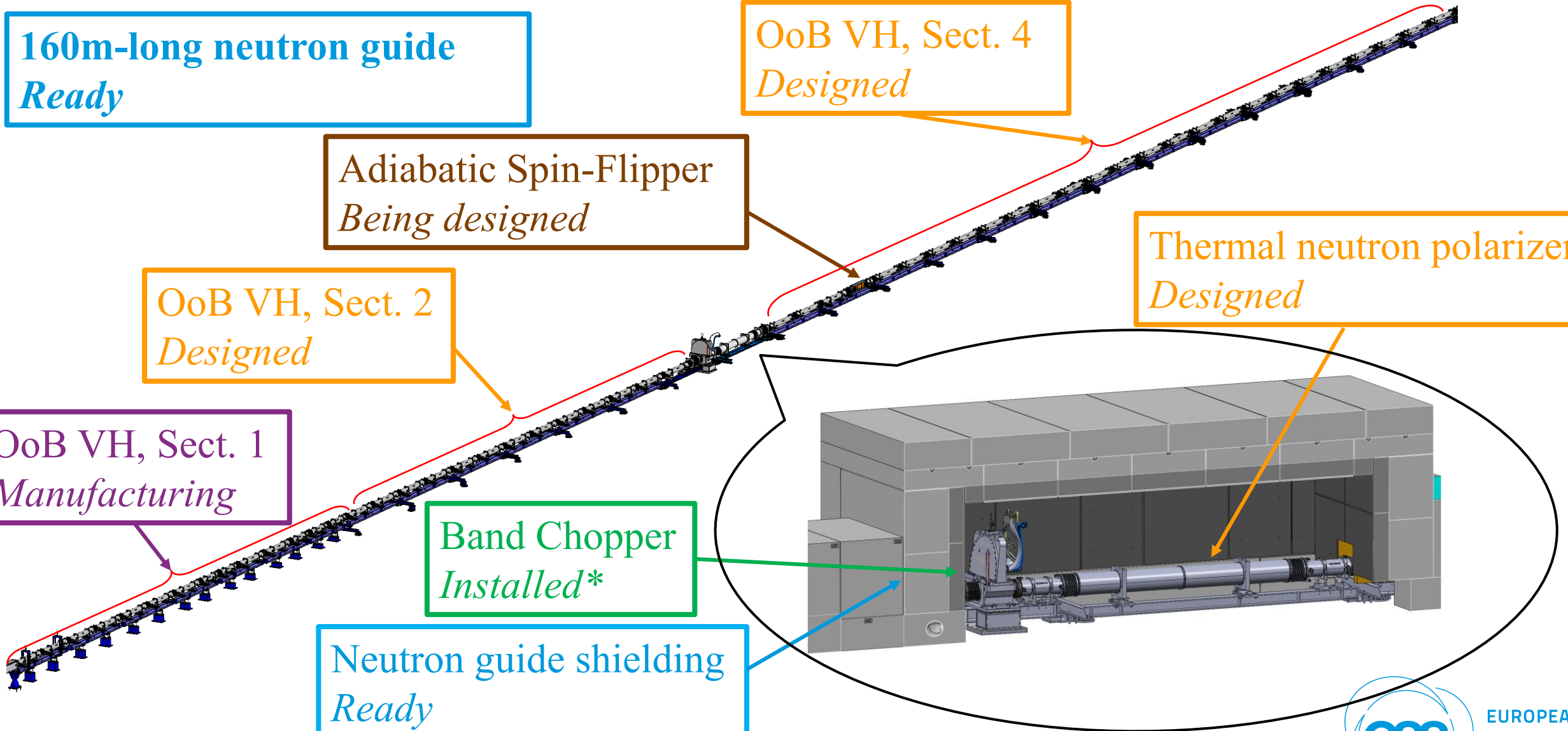

Out-of-Bunker Vacuum Housing

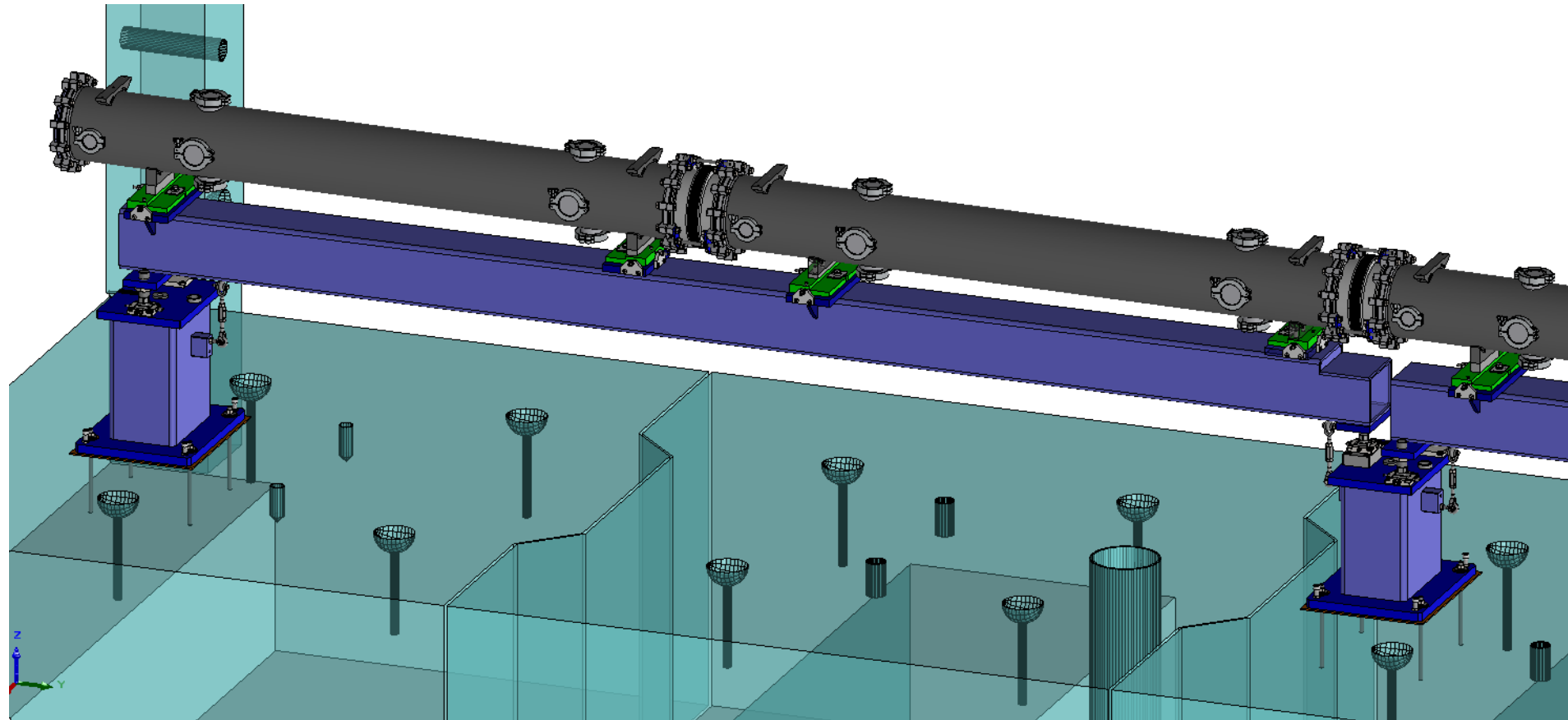

MIRRO•TRON

ICEB meeting *Vasiukov Denis* | *28th April 2026* | *Slide 12*

Out-of-Bunker Vacuum Housing, section 5

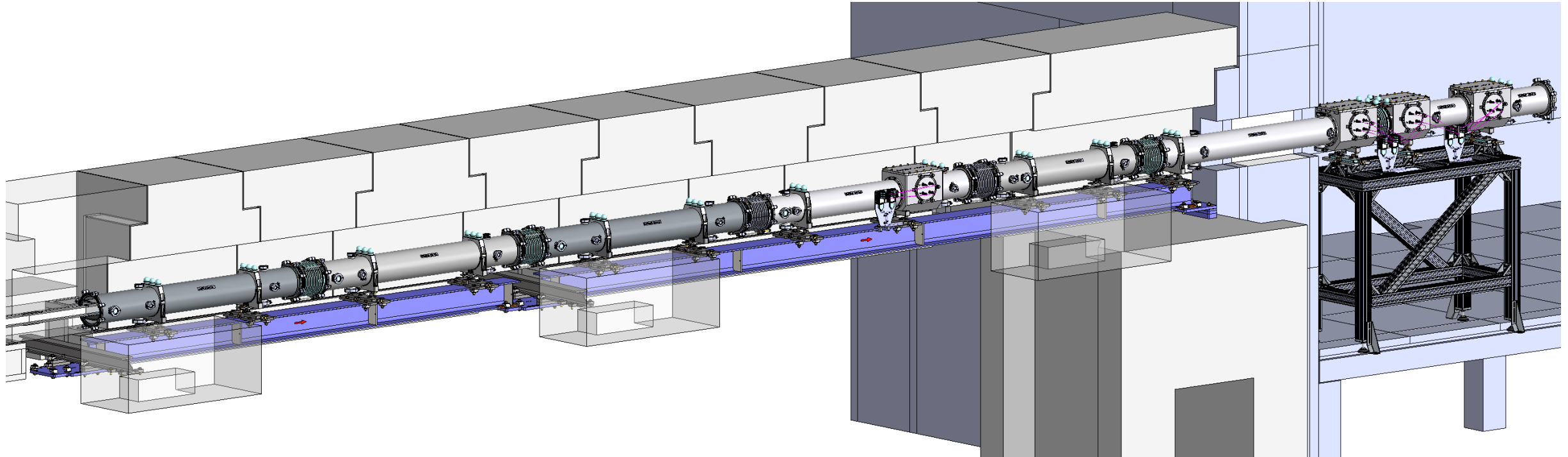

Band Chopper



Infrastructure

Experimental Cave

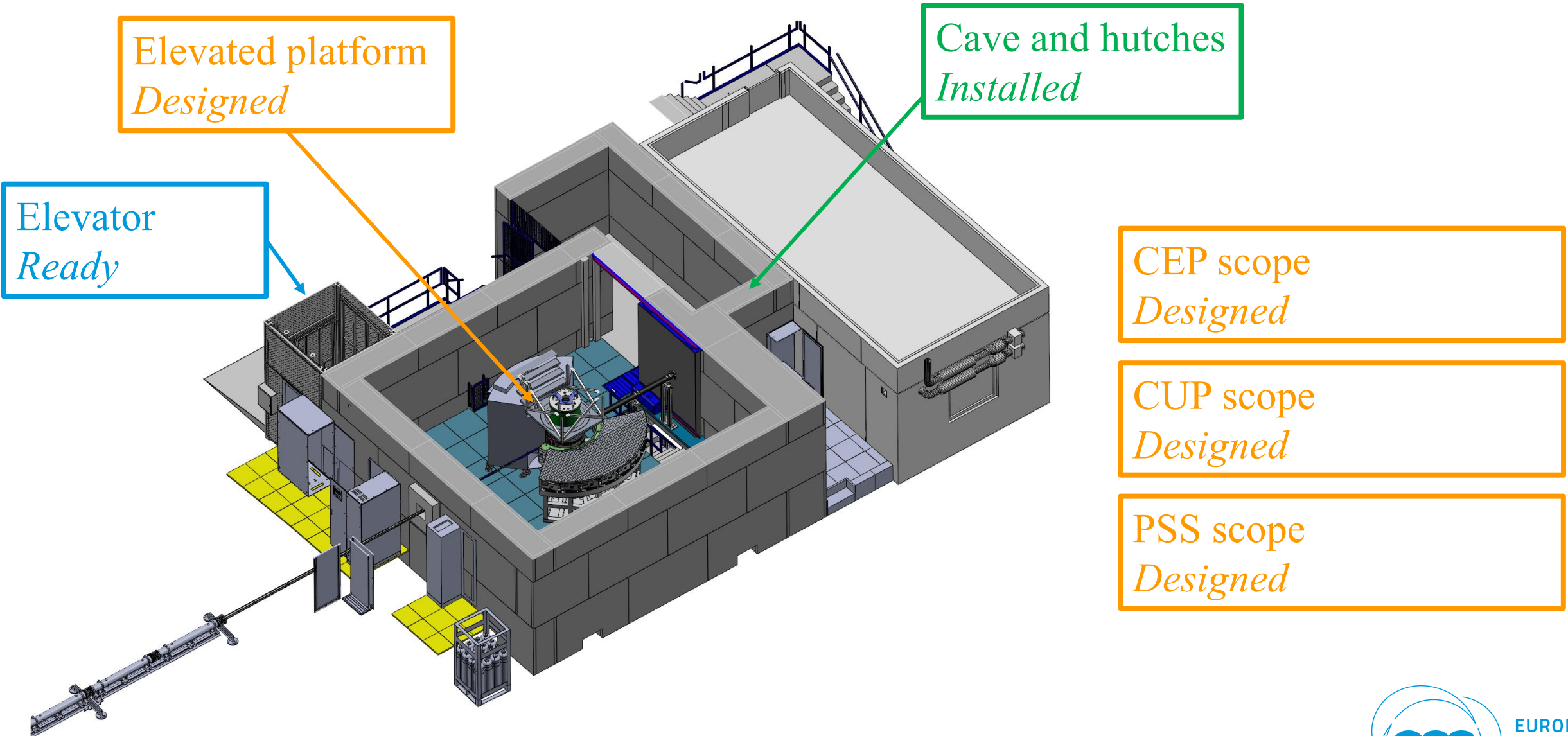

CEP and CUP design

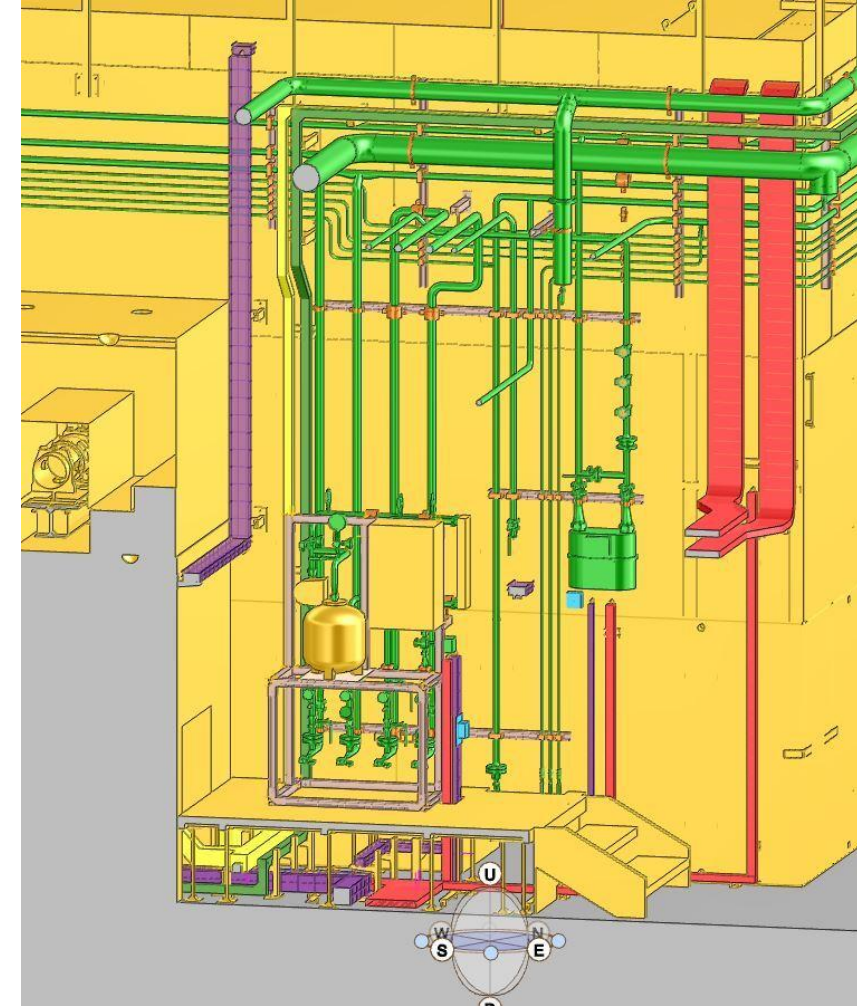
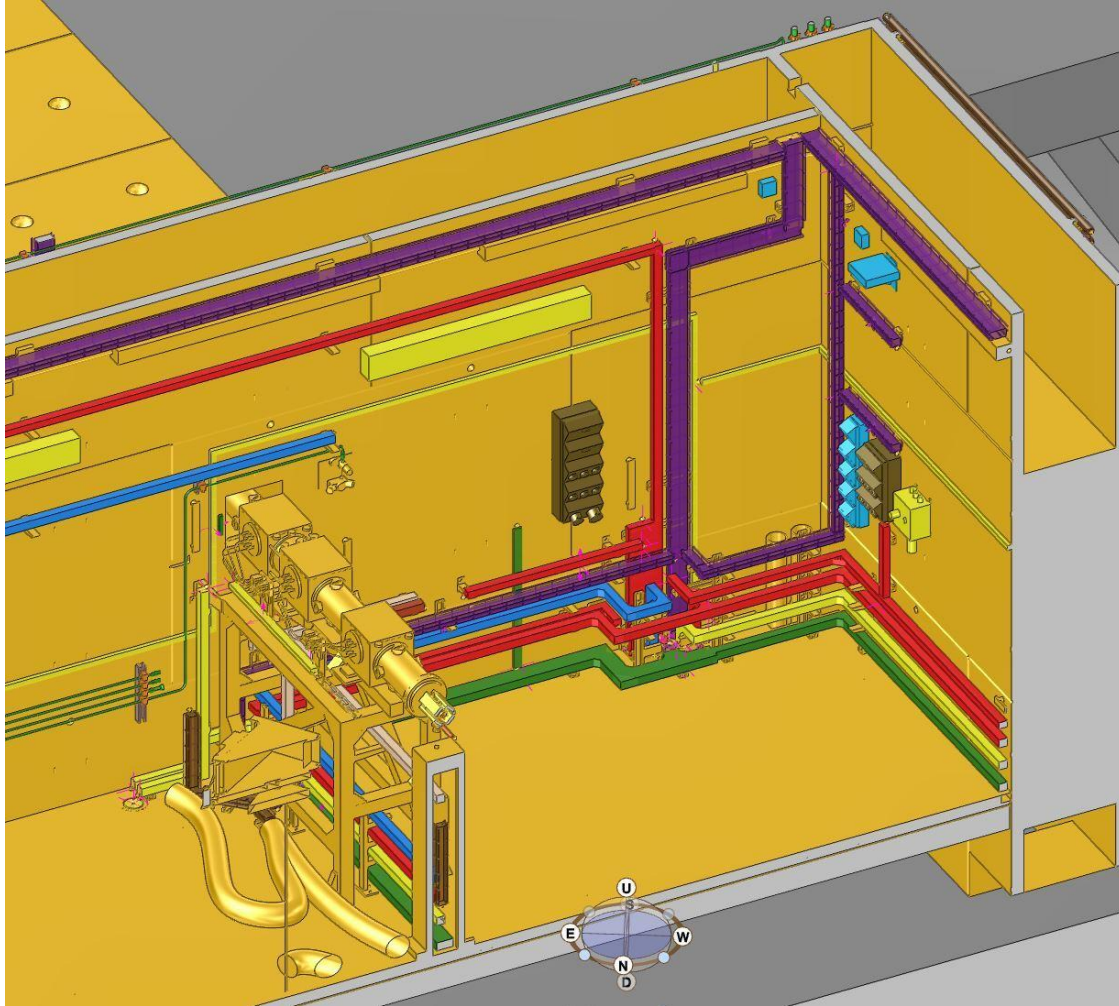

CEP and CUP design

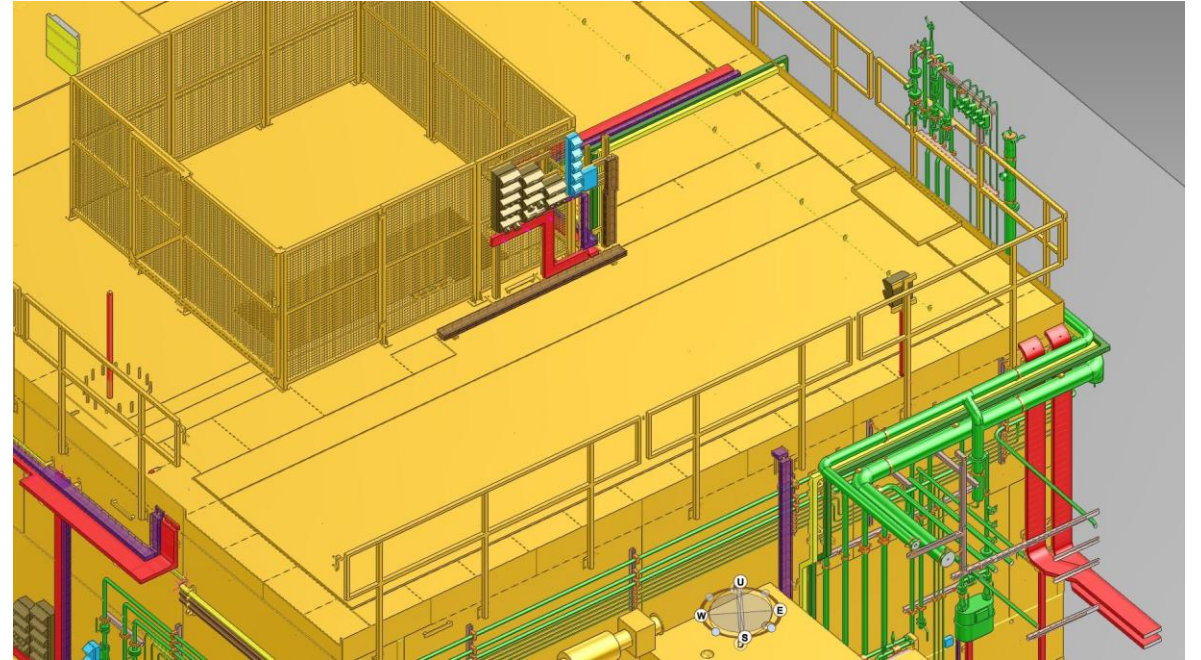
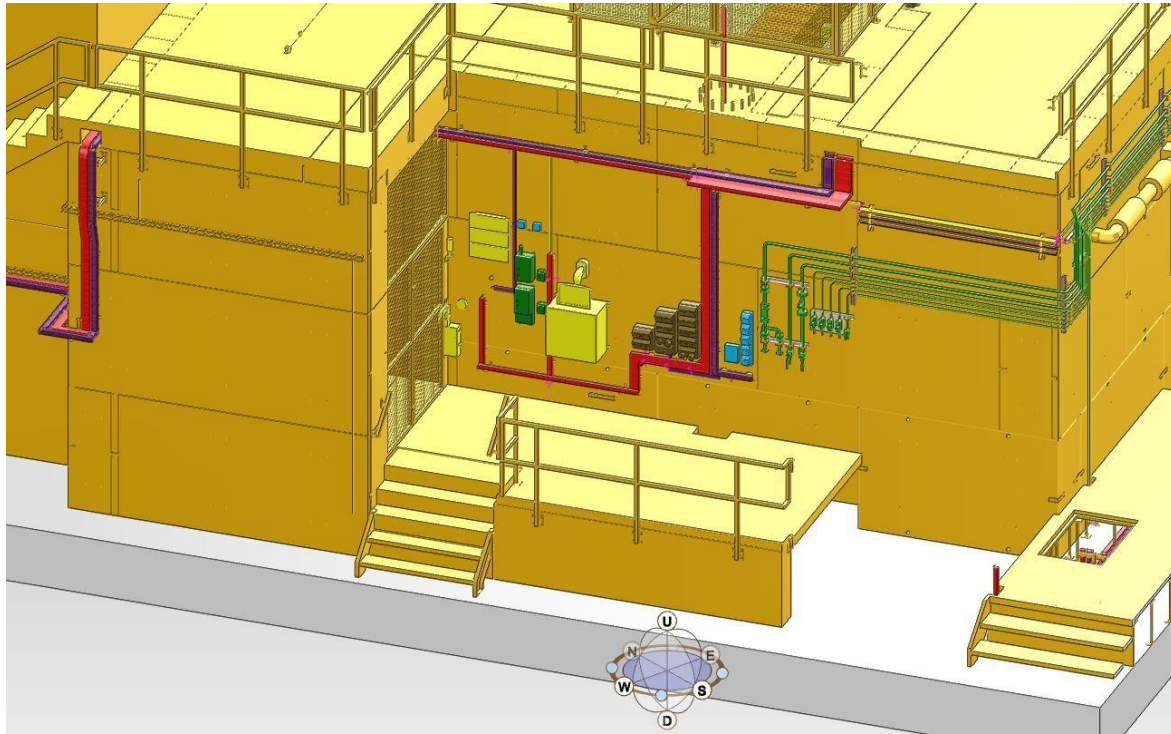

Goods elevator



ICEB meeting

Vasiukov Denis | 28th April 2026 | Slide 19

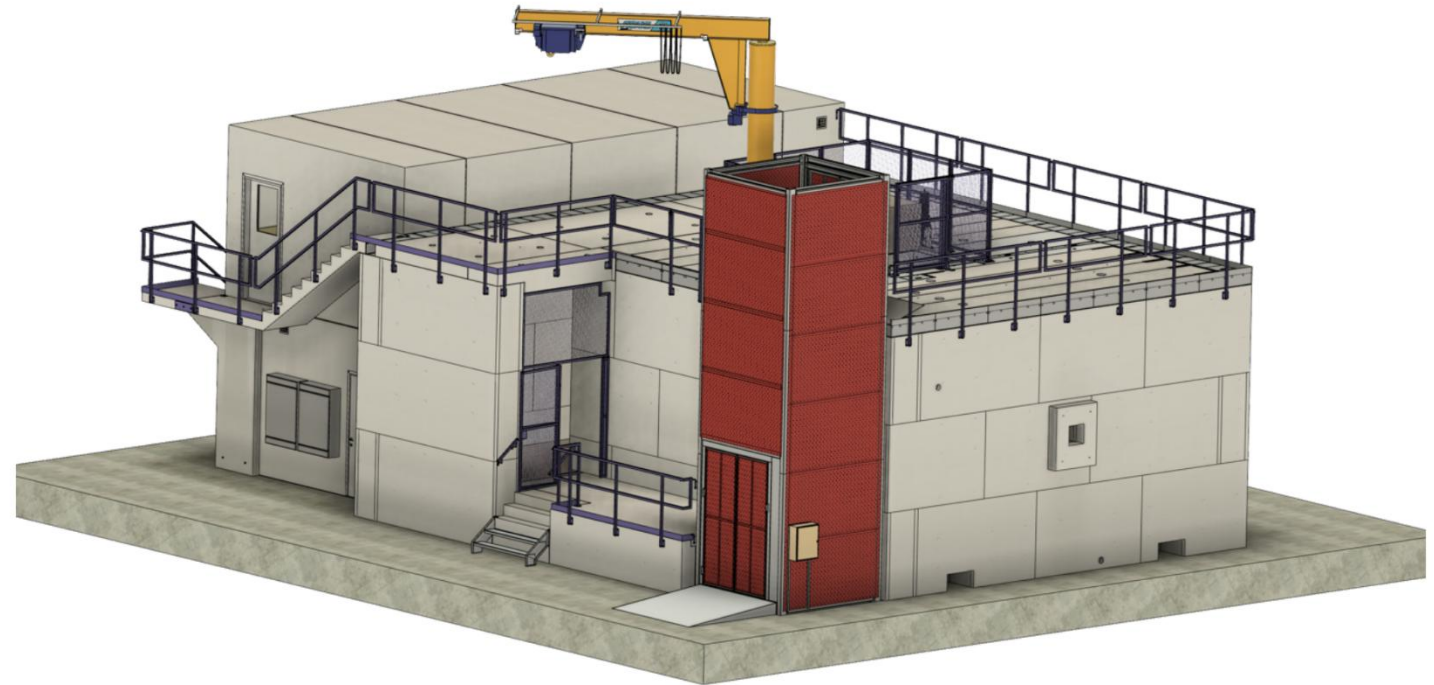

The installation in May

Beamstop

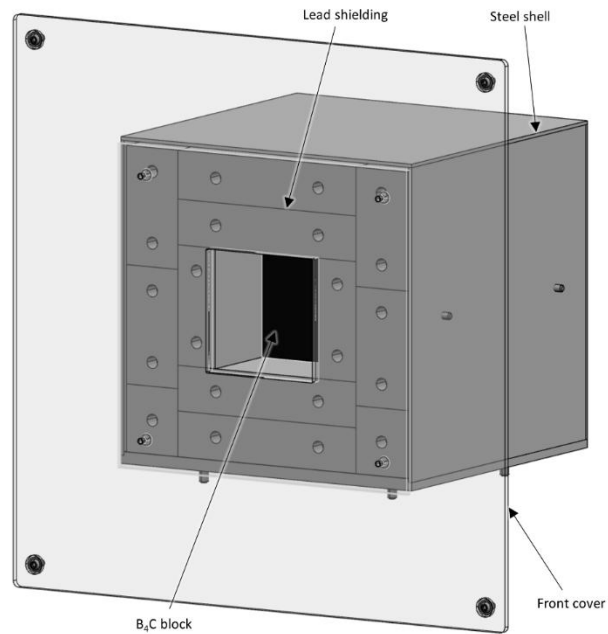

The installation next week

Elevated platform

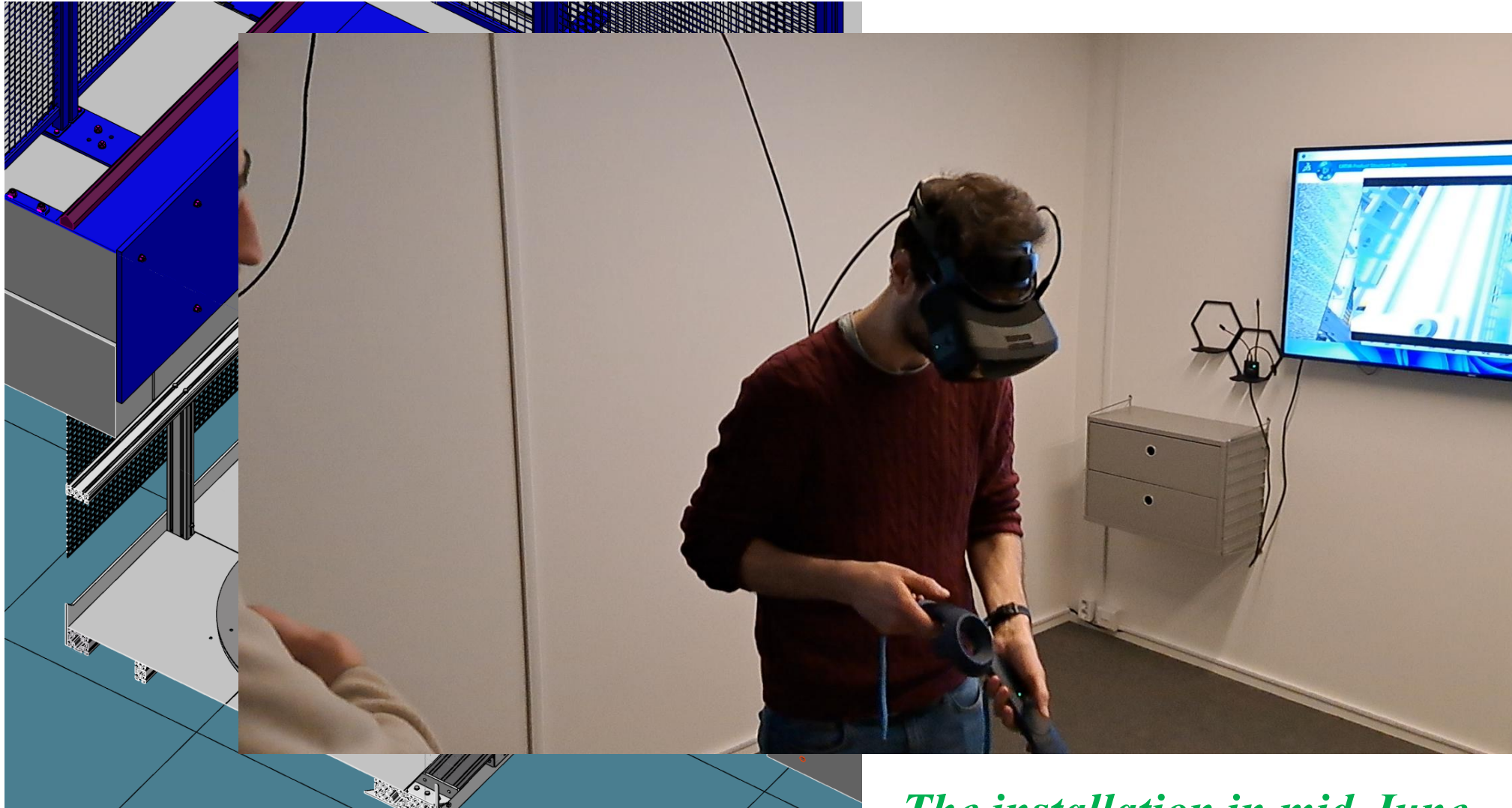

The installation in mid-June

ICEB meeting

Vasiukov Denis | 28th April 2026 | Slide 21

Infrastructure installations

- *Elevator in May*
- *Platform in June*
- *CEP installations begin in June*
- *ICS, CUP etc. will follow*



Scattering characterization system

Scattering characterization system

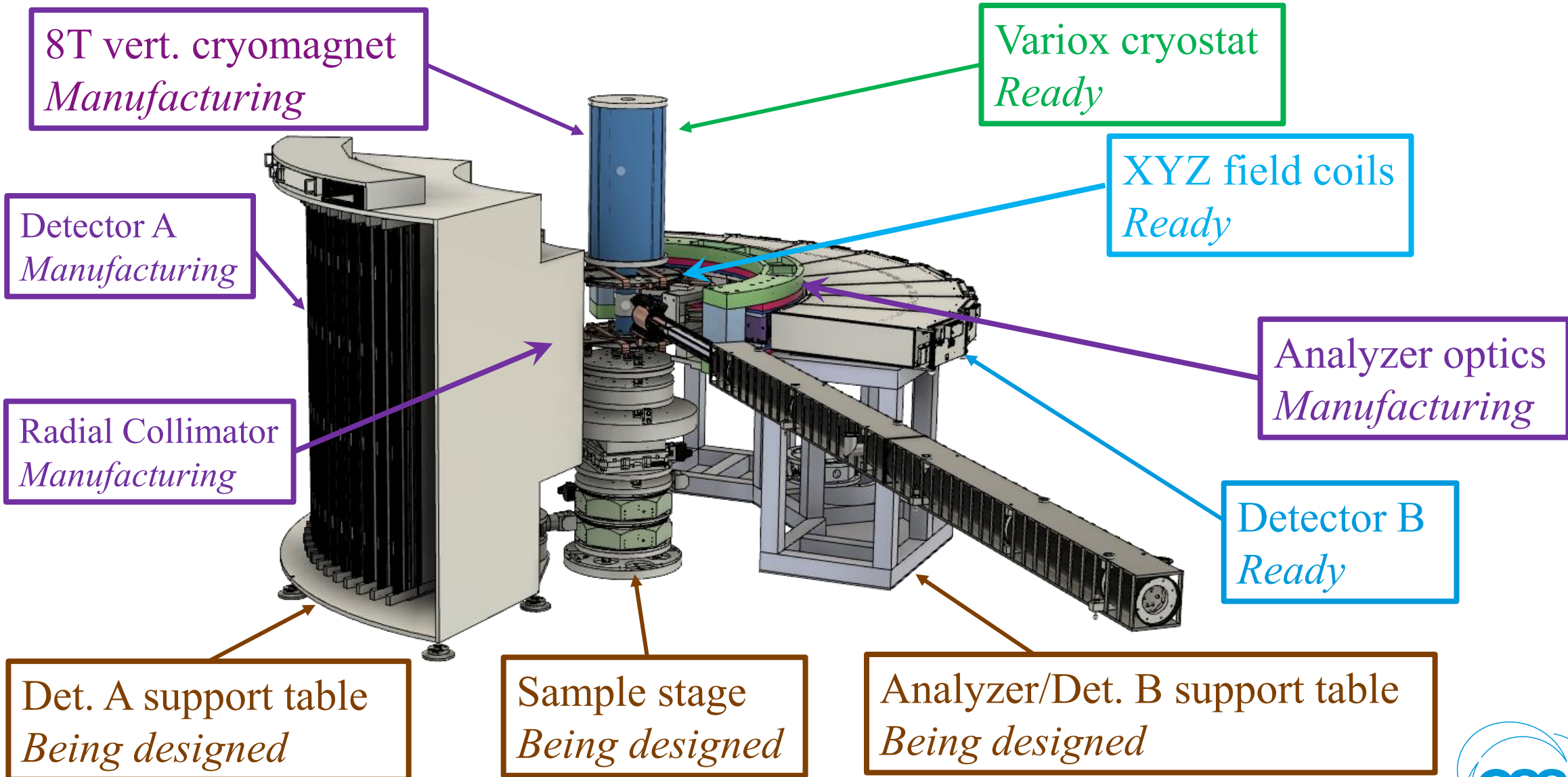

Analyzer + Detector B support structure

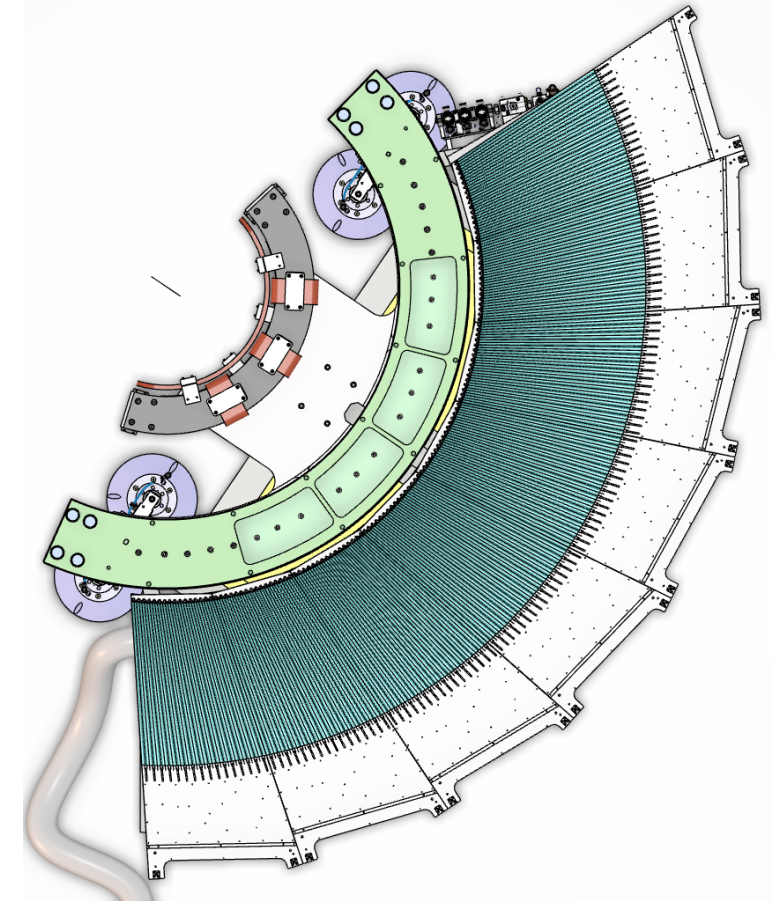
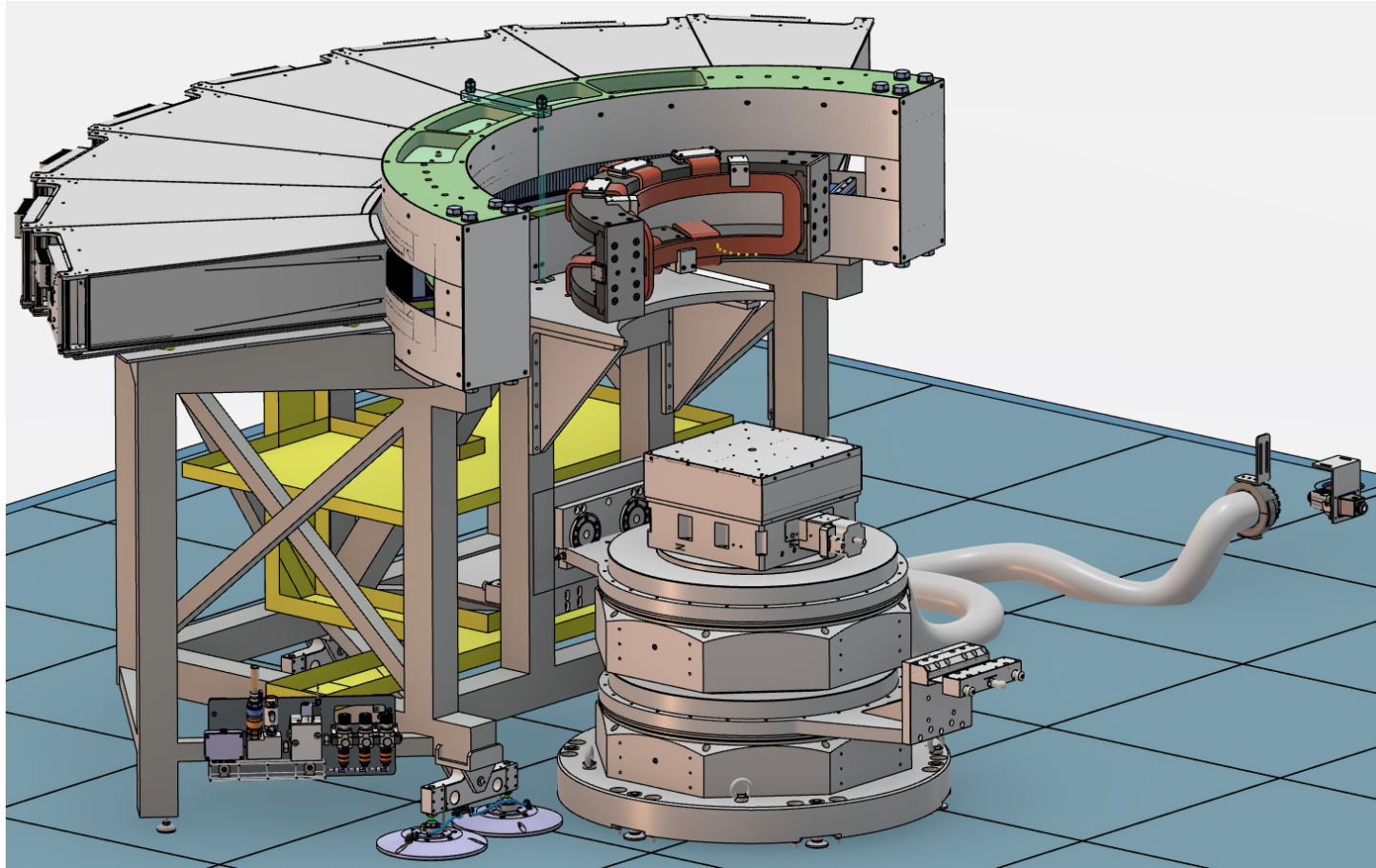

Detector A support structure

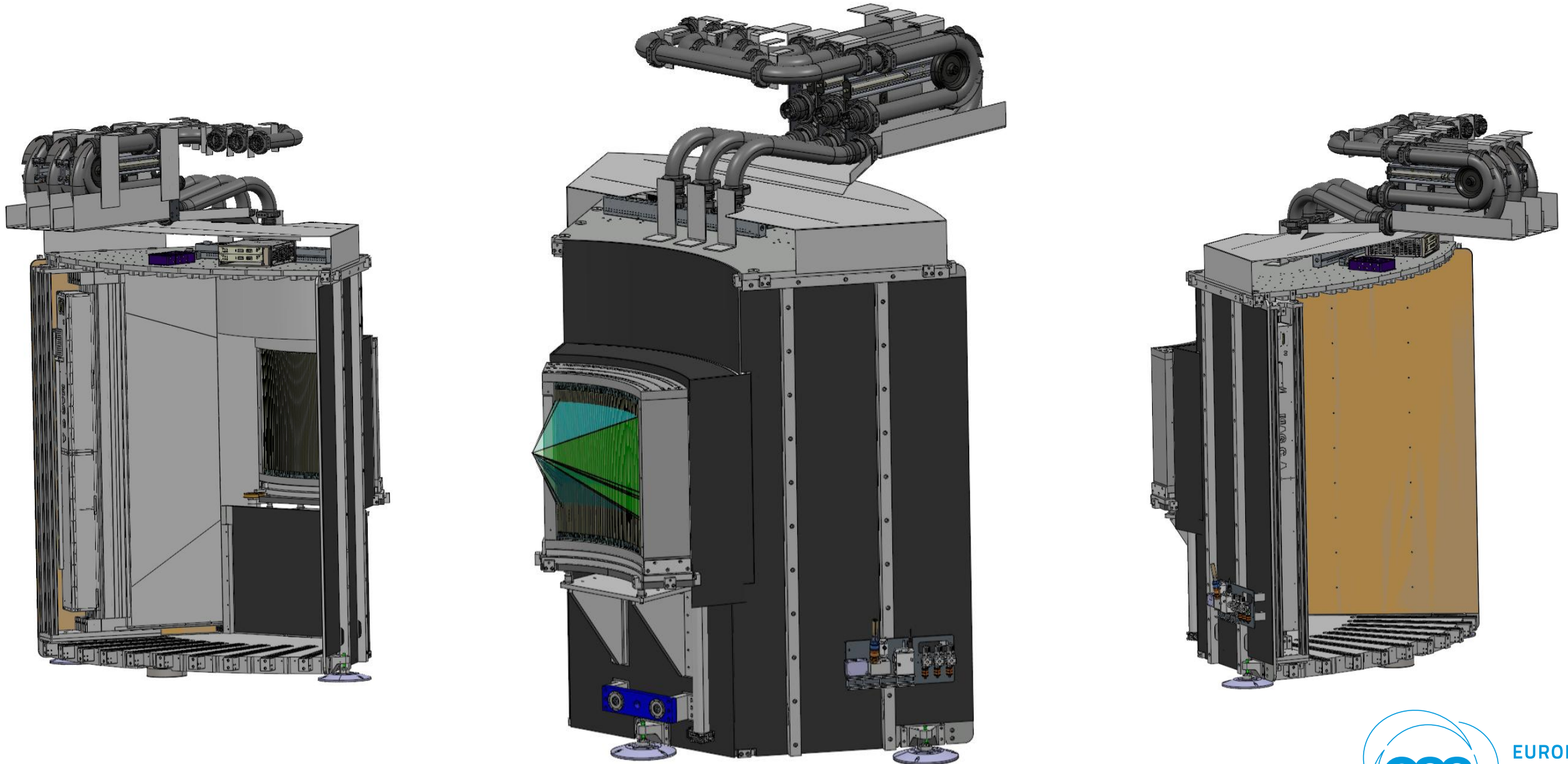

Radial Collimator

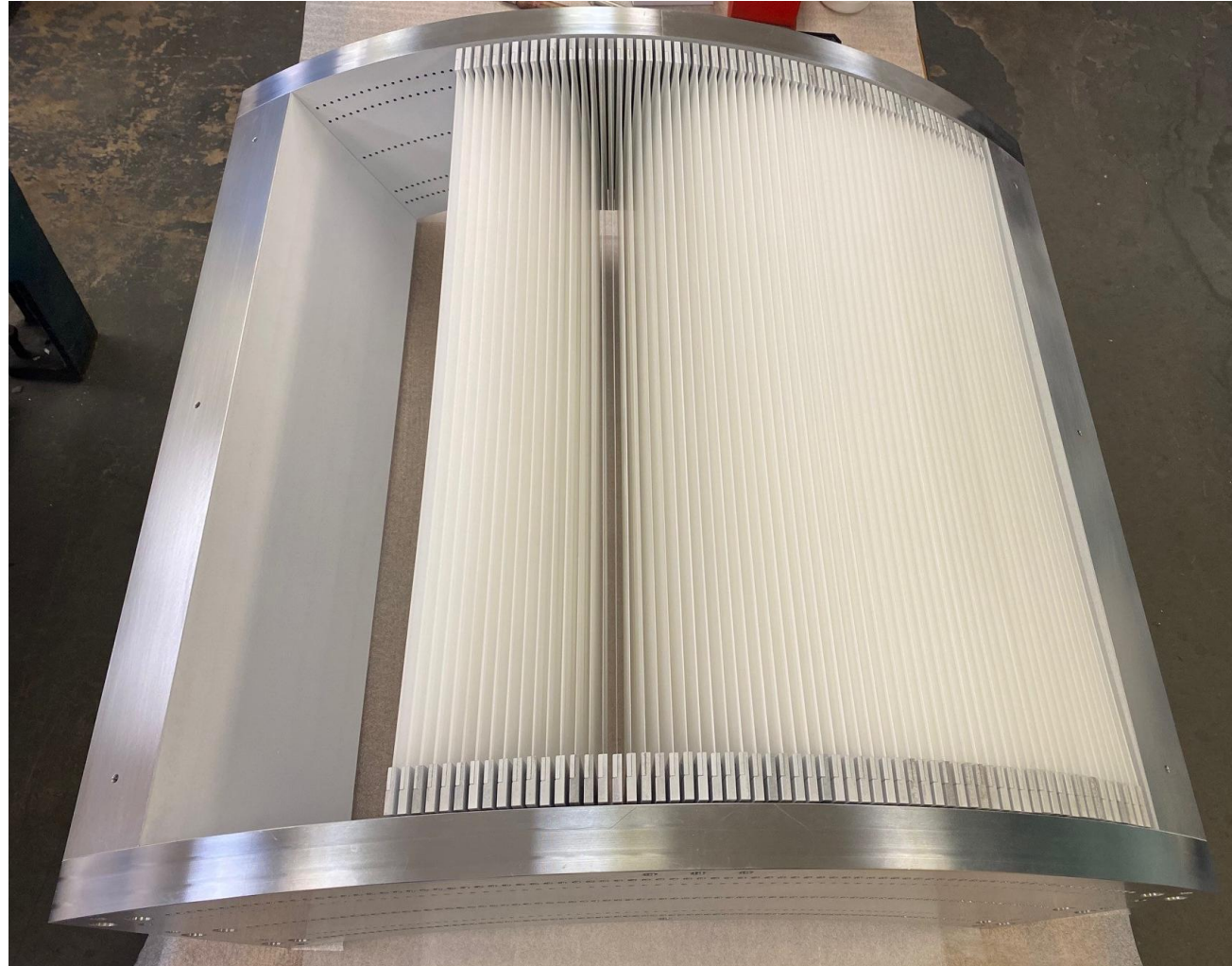

Detector A geometry issue

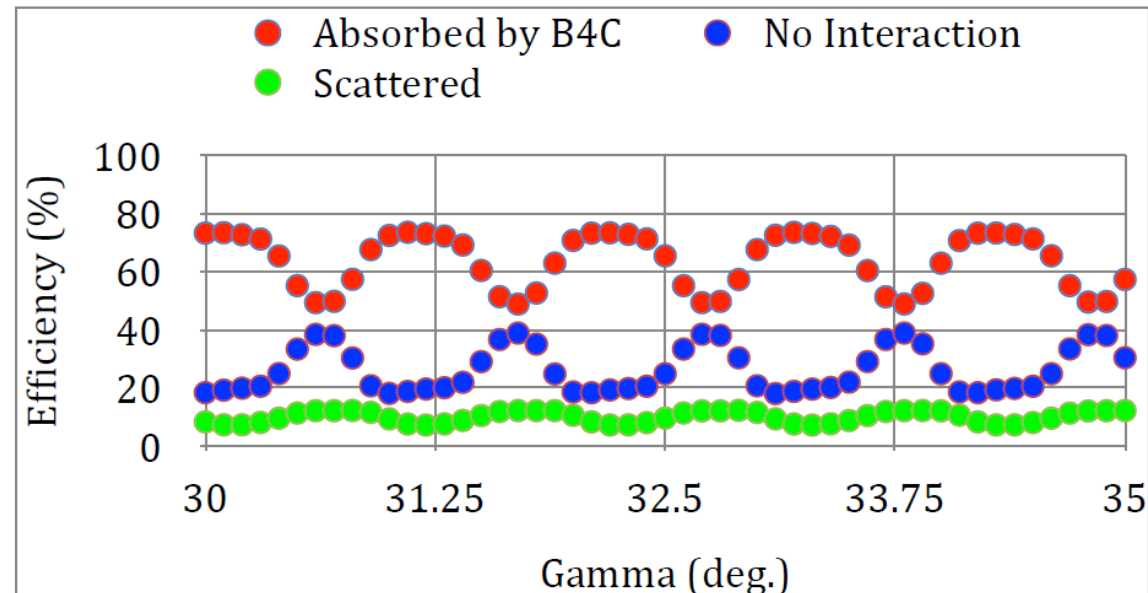
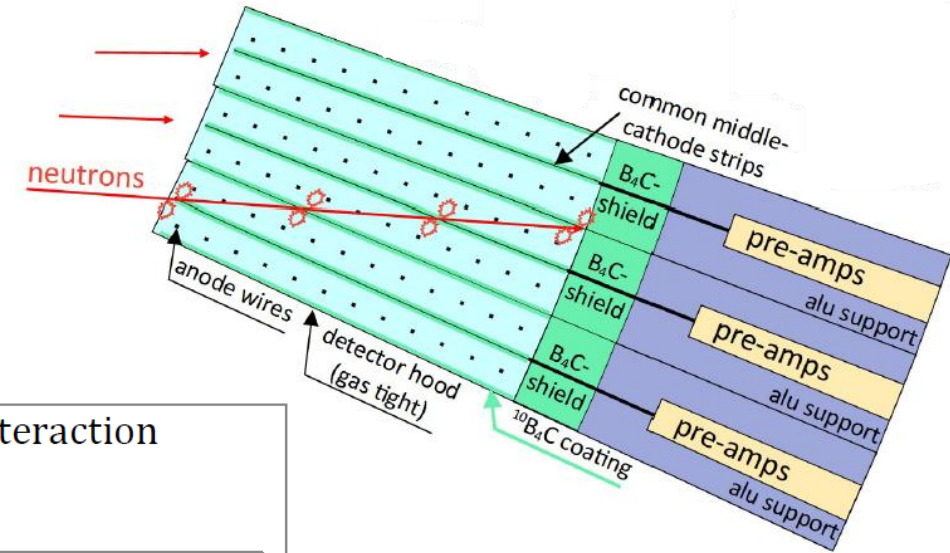
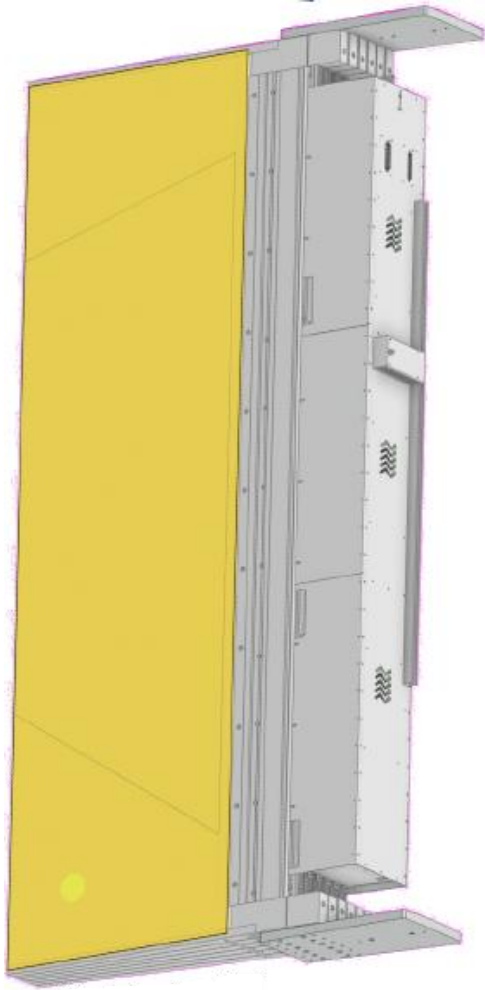

Estimated efficiency of Detector A at inclination 5 degrees and wavelength 1 angstrom as a function of Gamma.

Detector A geometry issue

Number of layers n	Optimal angle Ω (degrees)	$\Delta\gamma$ of voxel (degrees)
1	3.031	0.050
2	6.065	0.100
3	9.101	0.150
4	12.143	0.200

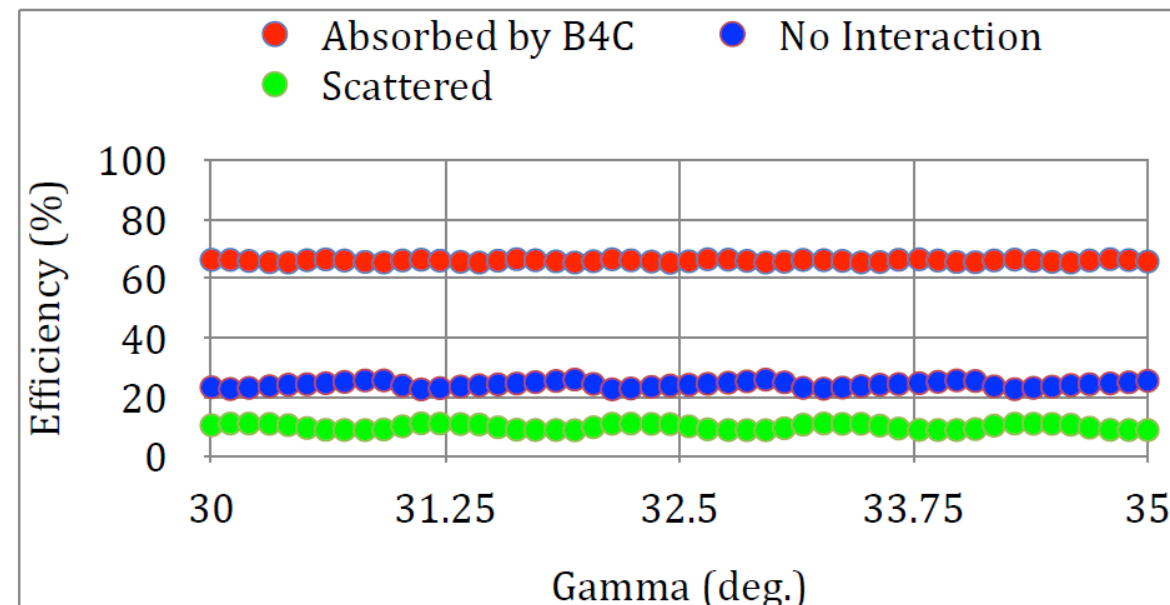
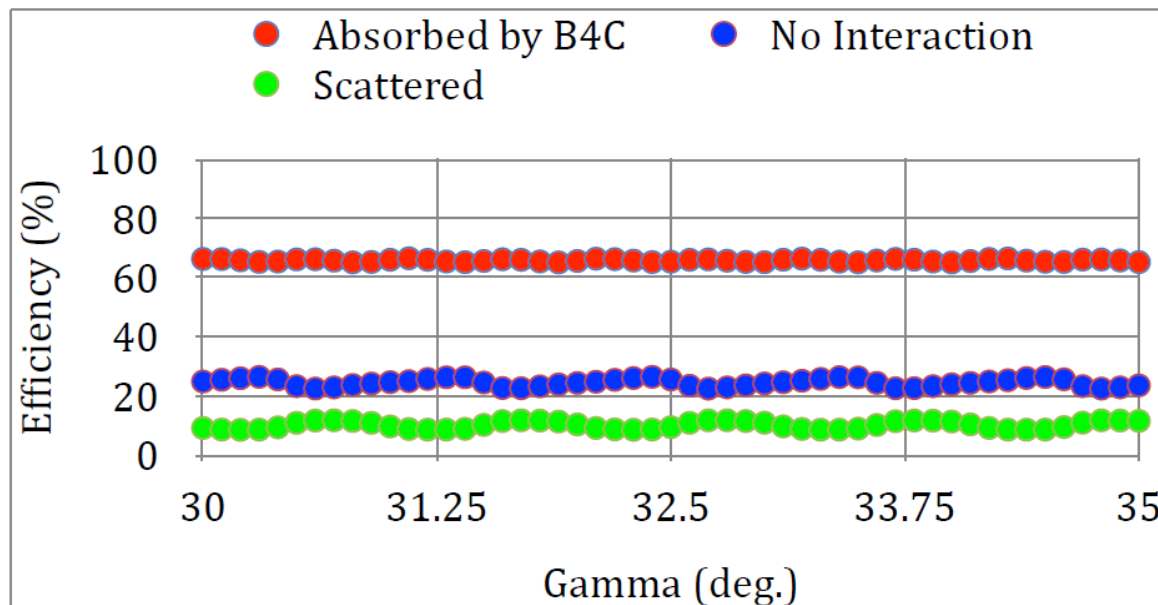

Estimated efficiency of Detector A at inclination 6.065 degrees and wavelength 1 angstrom as function of Gamma

Estimated efficiency of Detector A at inclination 9.101 degrees and wavelength 1 angstrom as function of Gamma

Test of the analyzer optics at ISIS

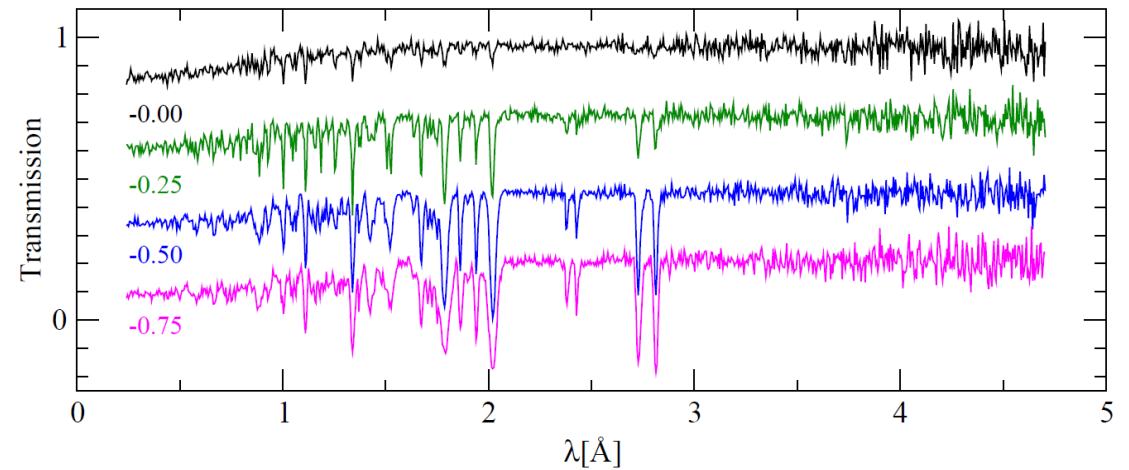
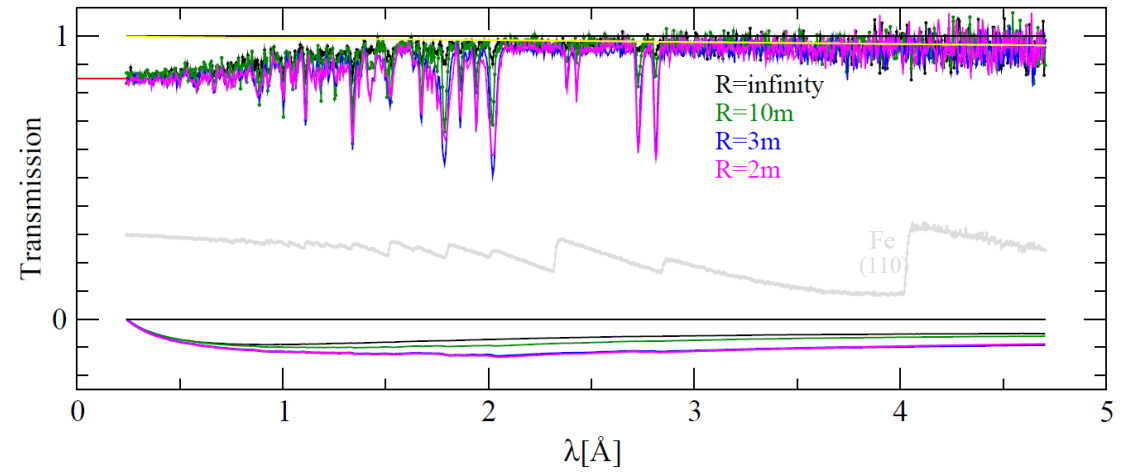
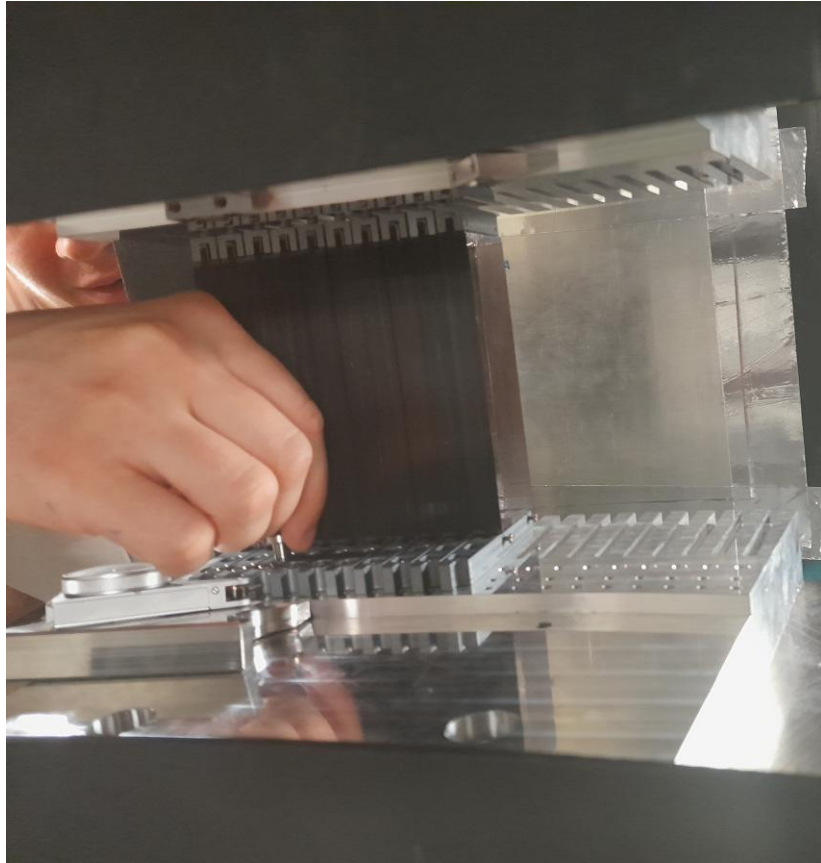

ToF experiment at IMAT instrument, 7 – 10 May

Sample stage

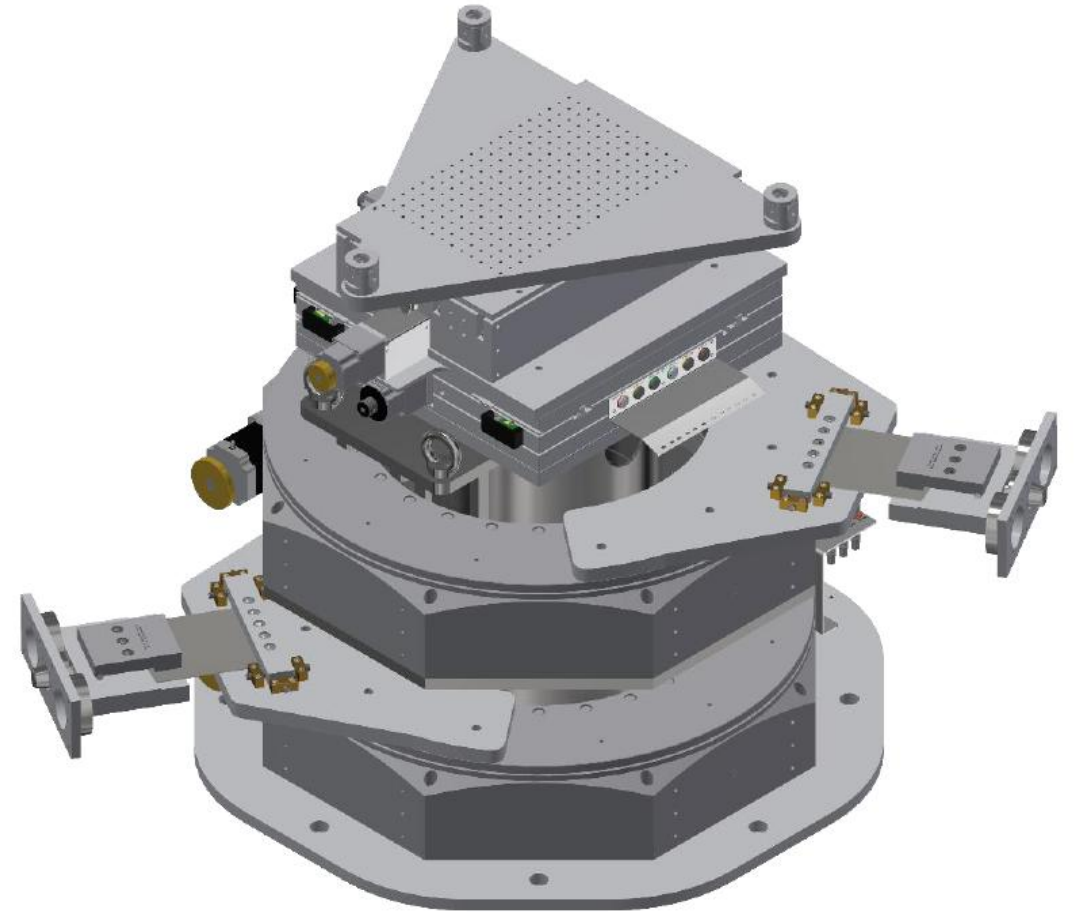
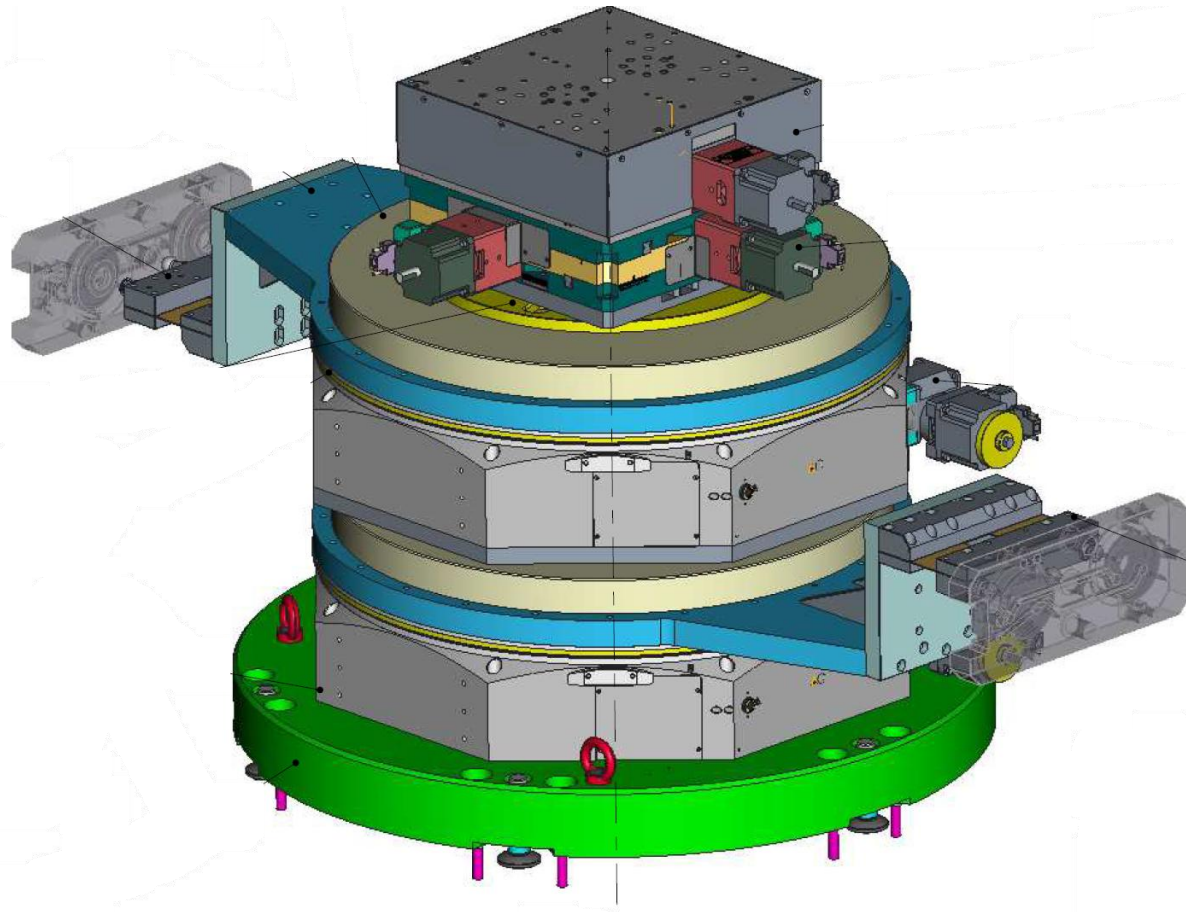

Magic Critical Paths

Data from P6 April 2026

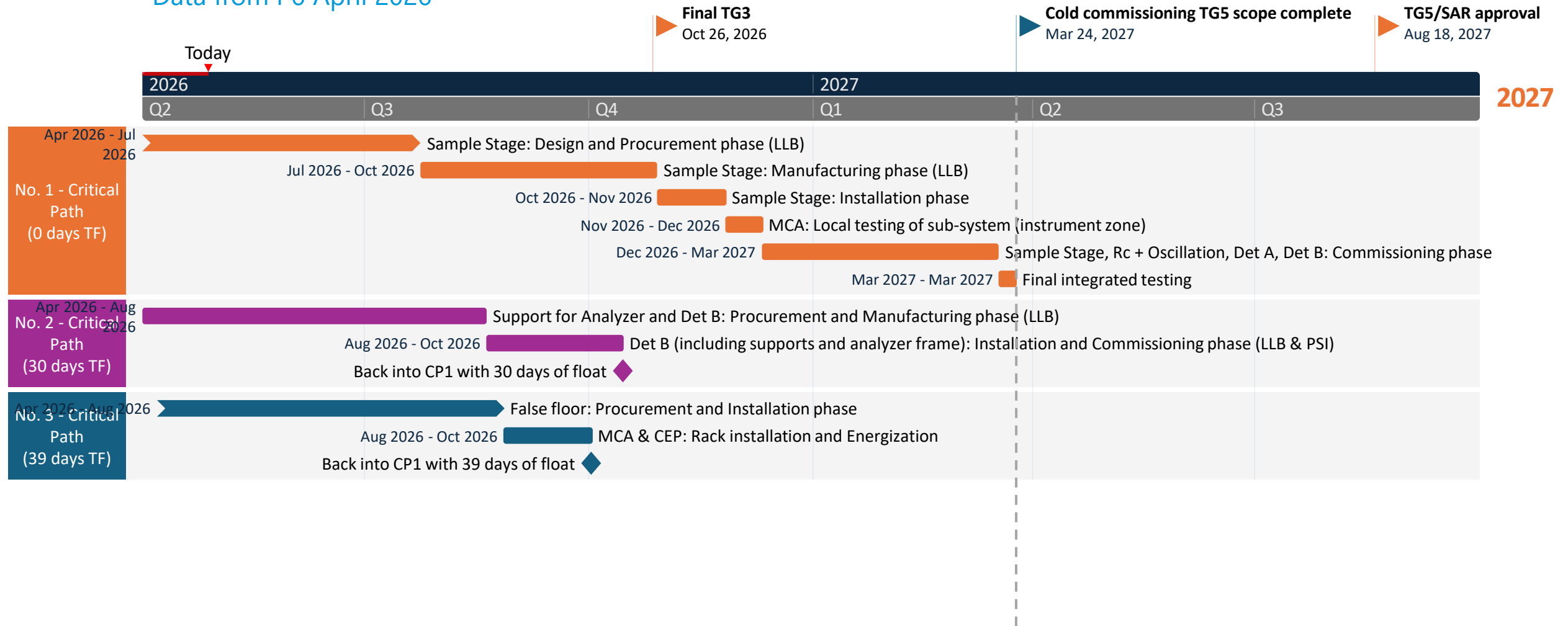

Design phase ends at CDR approval

Procurement and Manufacturing phase ends at FAT closure of open points

Installation and Commissioning phase ends at SAT approval

TF: number days of **total float** to Instrument's TG5

Note: Analyzer optics is part of the instrument scope but currently not linked to TG5 in P6

Magic Critical Paths

Data from P6 April 2026

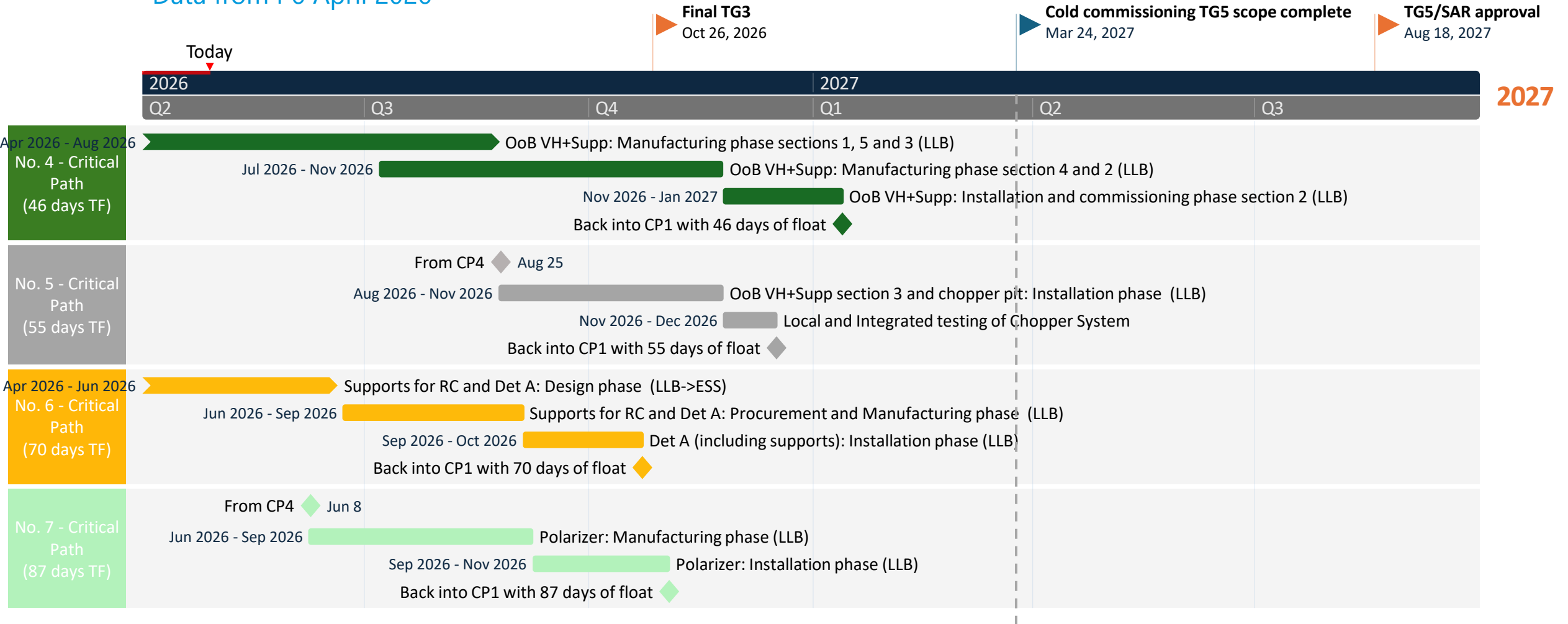

Design phase ends at CDR approval

Procurement and Manufacturing phase ends at FAT closure of open points

Installation and Commissioning phase ends at SAT approval

TF: number days of **total float** to Instrument's TG5

Note: Analyzer optics is part of the instrument scope but currently not linked to TG5 in P6