

BEER – Hereon Contribution

Jochen Fenske

Helmholtz-Zentrum Hereon
Head of the Department
„New Instrumentation for Neutron Scattering“

BEER – Hereon

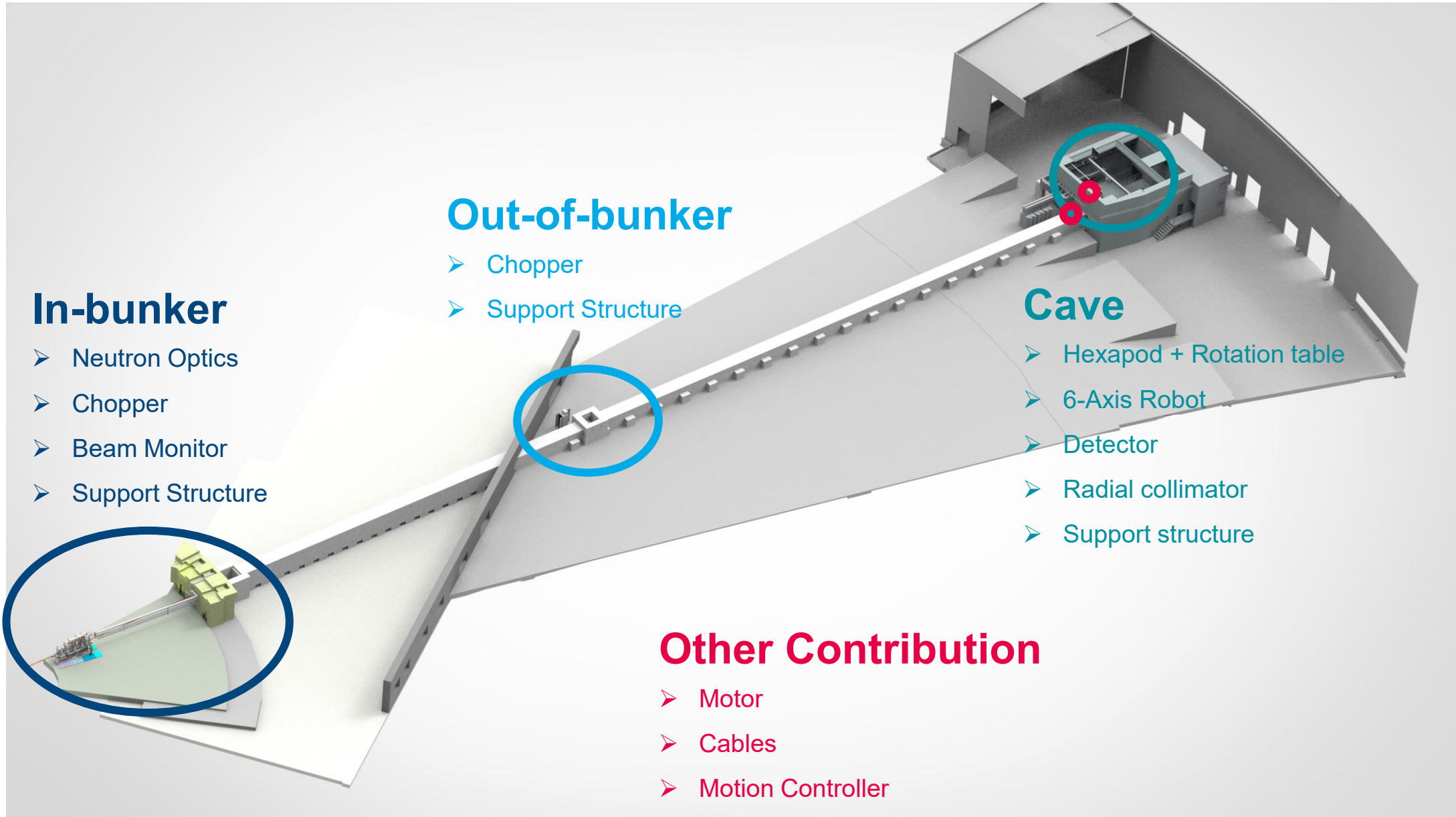

In-bunker

- Neutron Optics
- Chopper
- Beam Monitor
- Support Structure

Out-of-bunker

- Chopper
- Support Structure

Cave

- Hexapod + Rotation table
- 6-Axis Robot
- Detector
- Radial collimator
- Support structure

Other Contribution

- Motor
- Cables
- Motion Controller

In-bunker parts

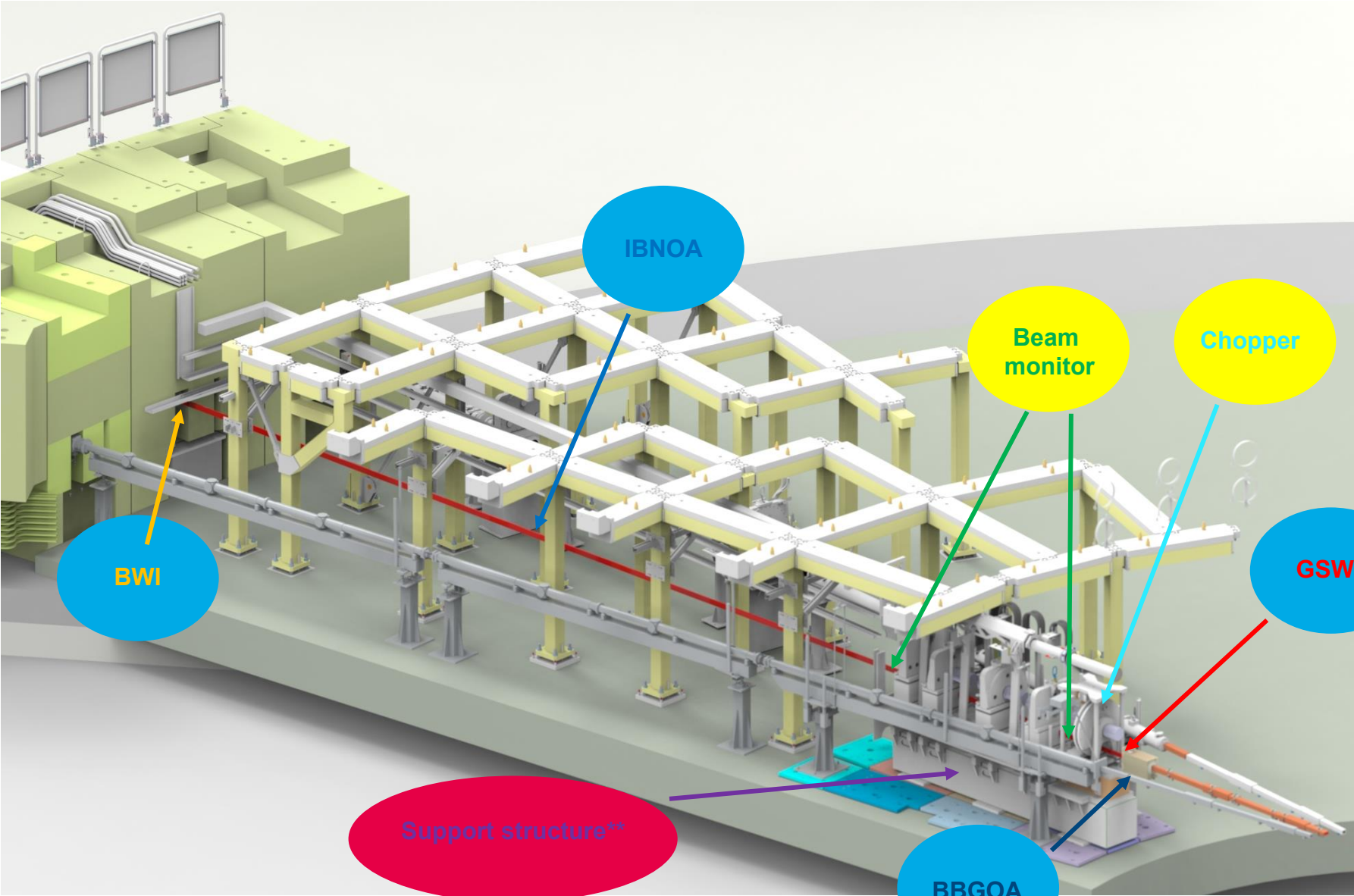

- In-house by Hereon
- Procurement
- Common Project

** Including linear table for Chopper+girder

* cable and controller by Hereon

In-bunker parts – design and process status

BBGOA

Supplier:

Installed

SDH

Issues/Risks:

- None



In-bunker parts – design and process status

GSW

✓ CDR



✓ Manufacturing finished



✓ Shipment



Installation together with Choppers

Supplier:

Mirrotron

Issues/Risks:

- none

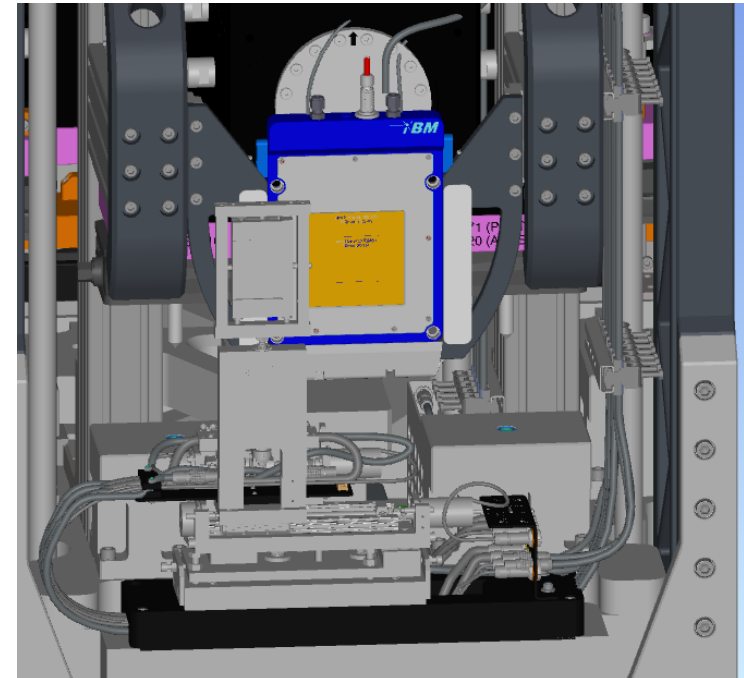
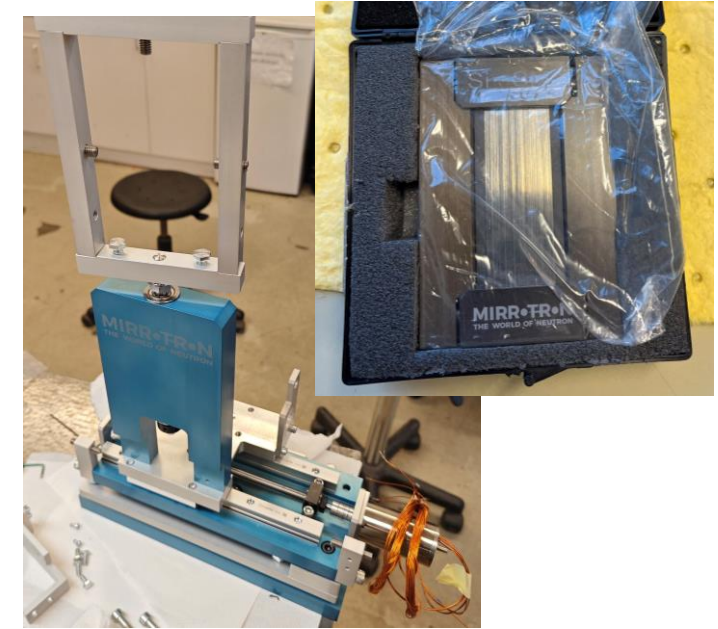

In-bunker parts – design and process status

IBNOA

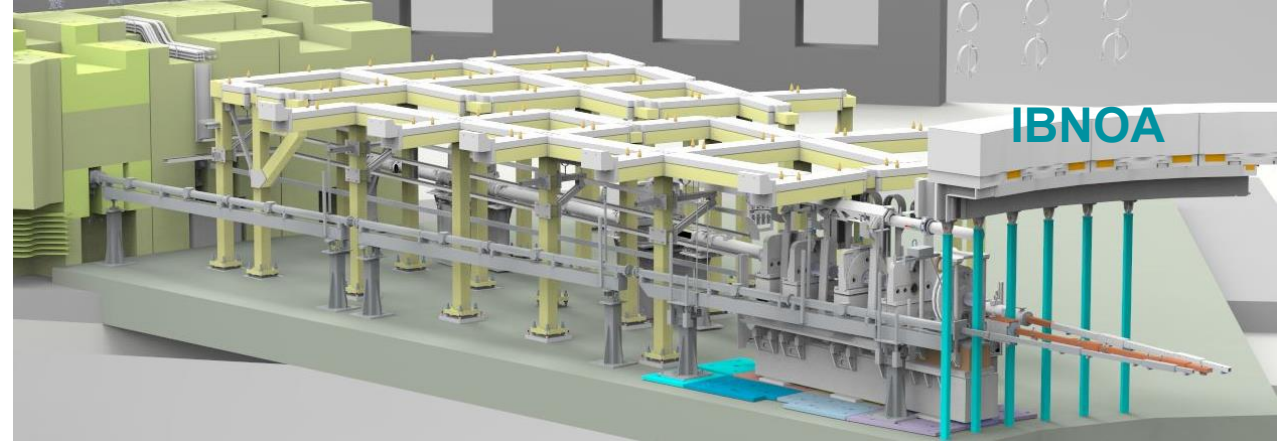

✓ IDR



✓ CDR



✓ Manufacturing finished



✓ Shipment



Installation → this week

Supplier:

SDH

Issues/Risks:

- none



In-bunker parts – design and process status

BWI

BWI

Installed

Supplier:

SDH

Issues/Risks:

- none



In-bunker parts – design and process status

Chopper assemblies

✓ PDR



✓ CDR



✓ Manufacturing finished



Installation on going

Supplier:

NCG

Issues/Risks:

- testing

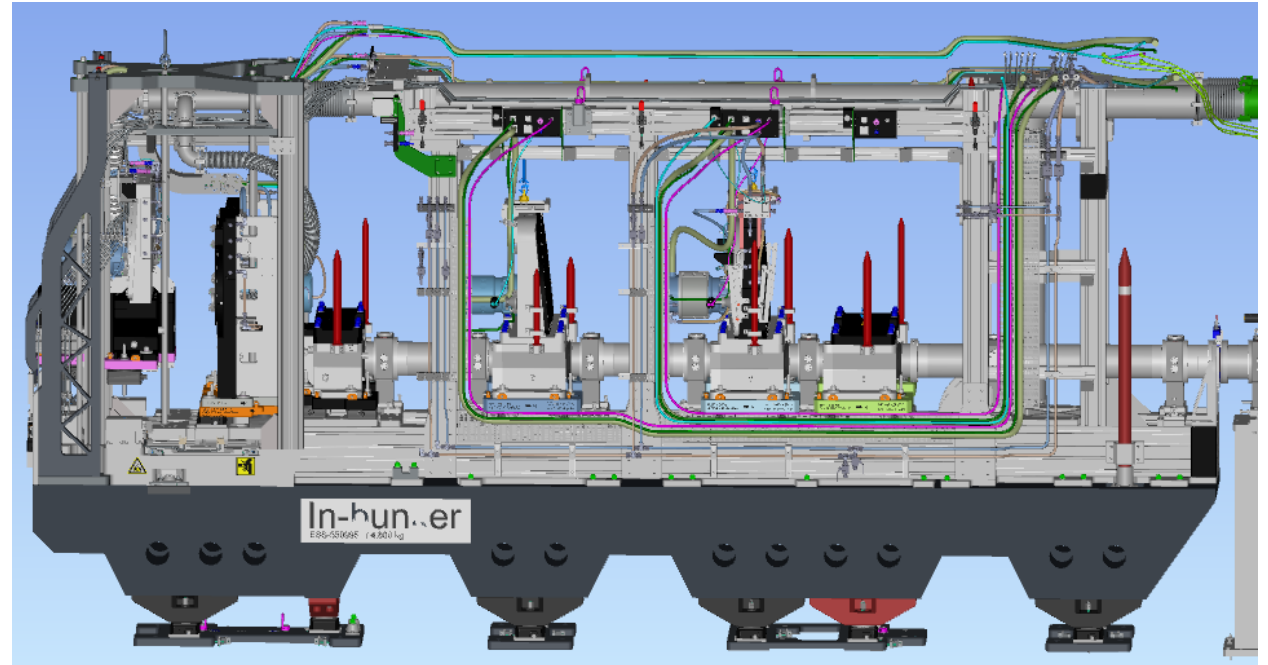

In-bunker parts – design and process status

Support structure

✓ IDR



CDR June/July 2026



Manufacturing on going



Shipment August 2026



Installation tbd

Supplier:

Hereon

Issues/Risks:

- Chopper and MCA testing

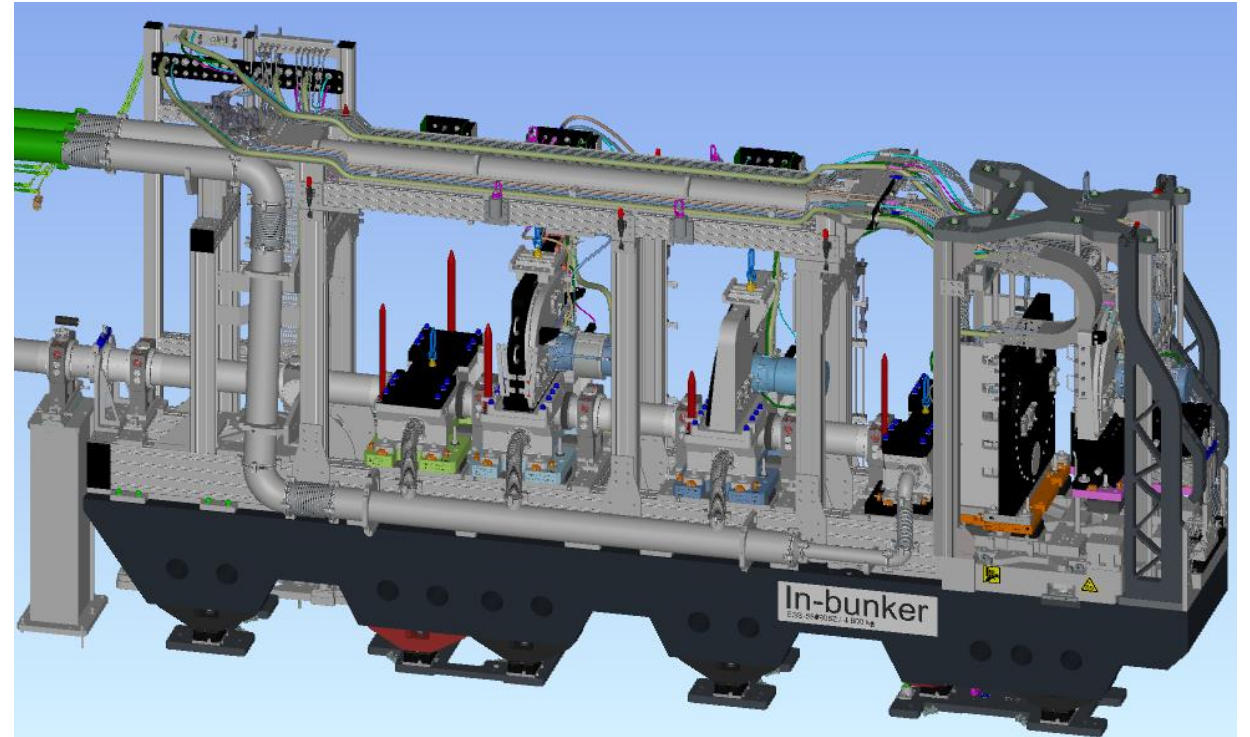

In-bunker parts – design and process status

Beam Monitor*

Supplier:

Detector Group

✓ IDR



✓ CDR



✓ Manufacturing finished



✓ Shipment



Installation tbd

Issues/Risks:

- Installation schedule tbd

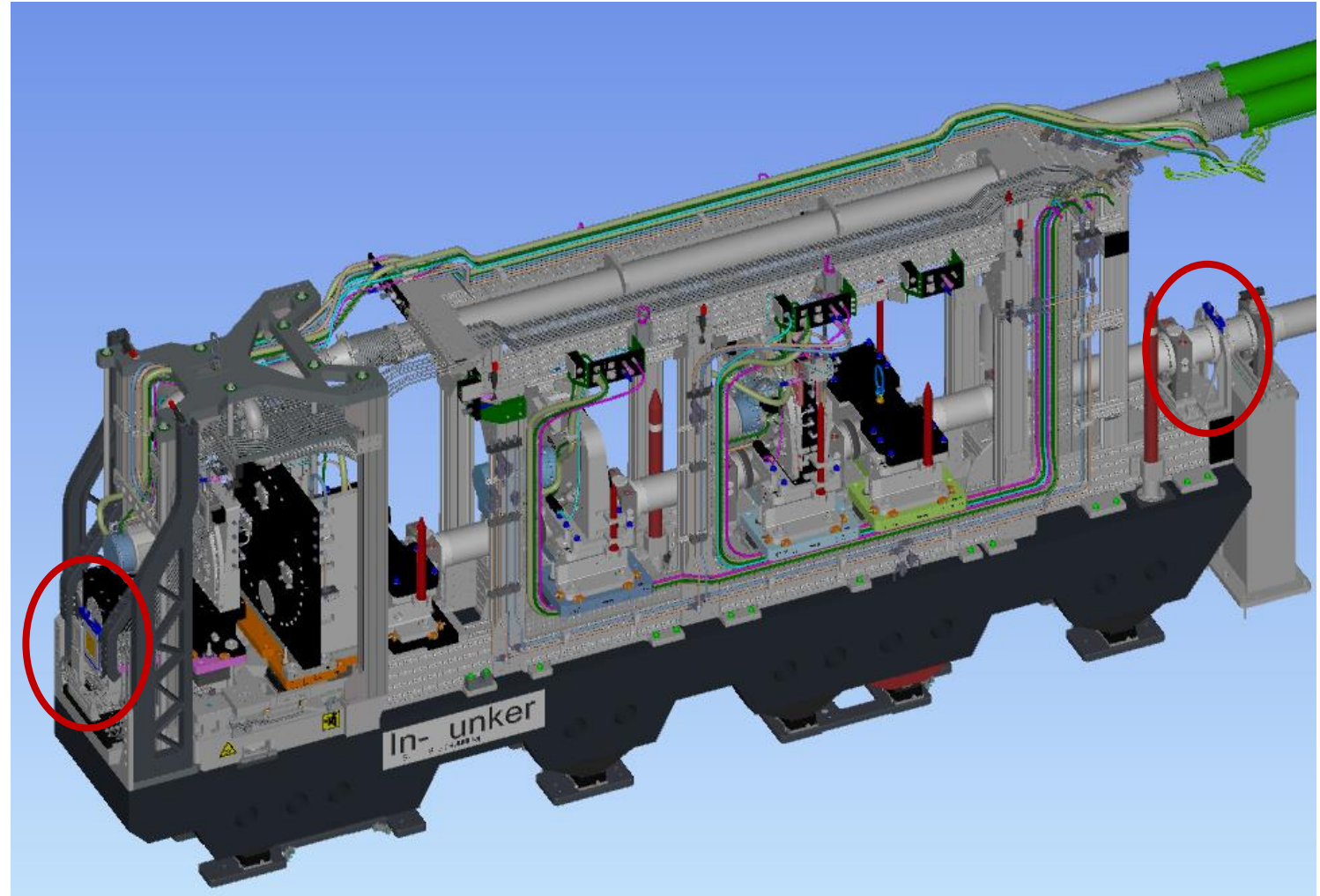

BEER – Hereon

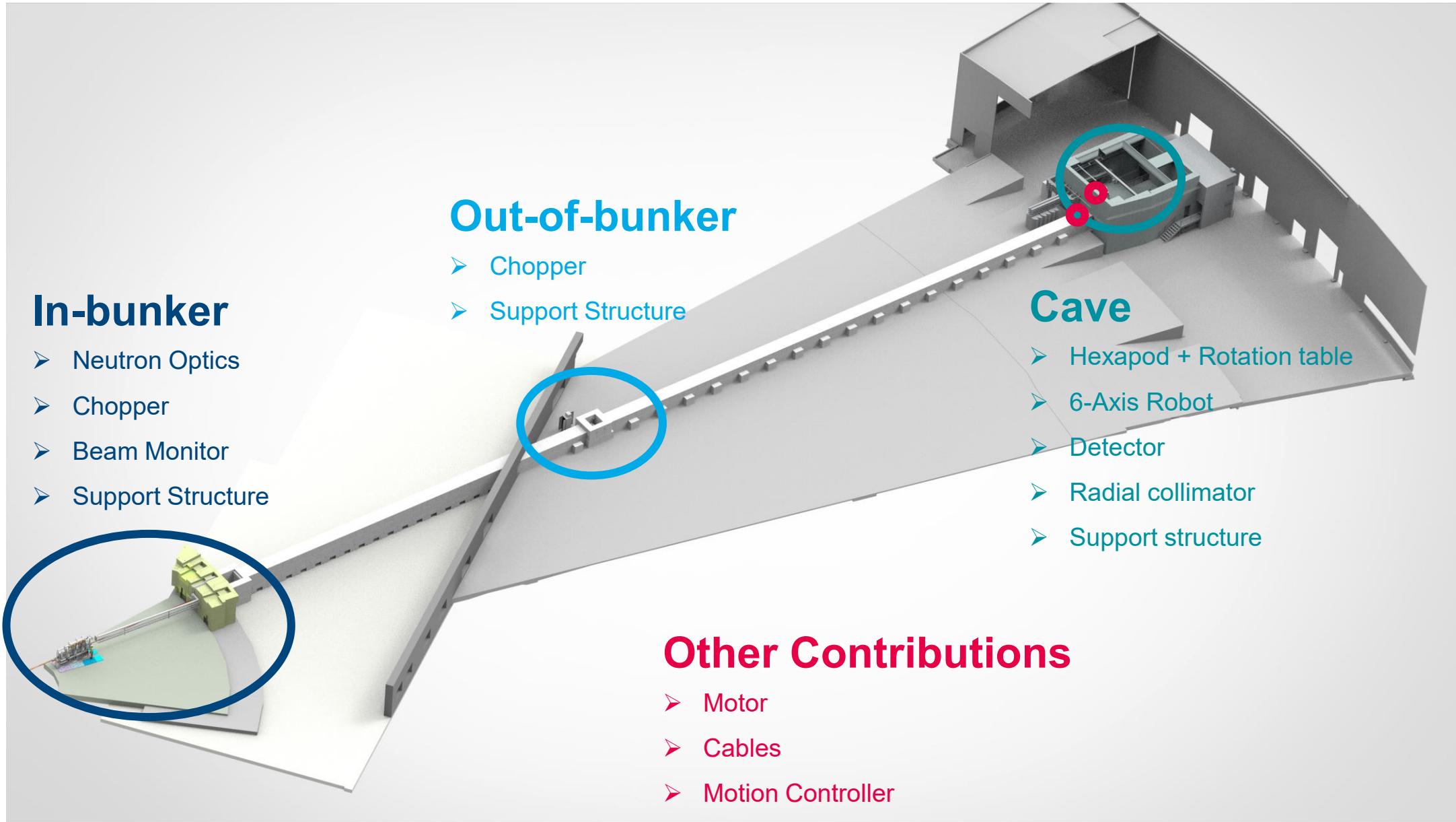

In-bunker

- Neutron Optics
- Chopper
- Beam Monitor
- Support Structure

Out-of-bunker

- Chopper
- Support Structure

Cave

- Hexapod + Rotation table
- 6-Axis Robot
- Detector
- Radial collimator
- Support structure

Other Contributions

- Motor
- Cables
- Motion Controller

Out-of-bunker parts

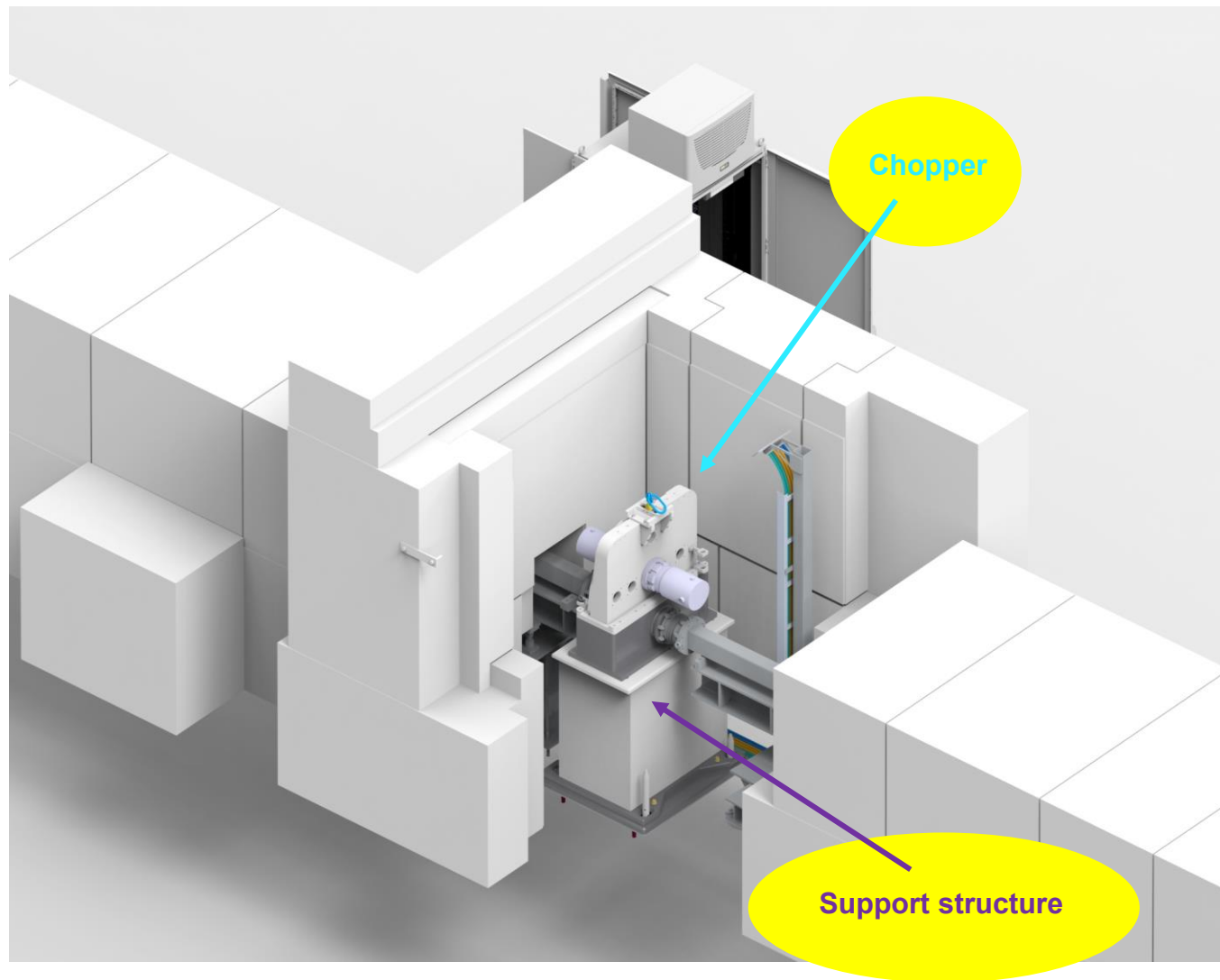

 Common Project

Out-of-bunker parts – design and process status

Chopper

Supplier:

NCG

Installed

Issues/Risks:

- none

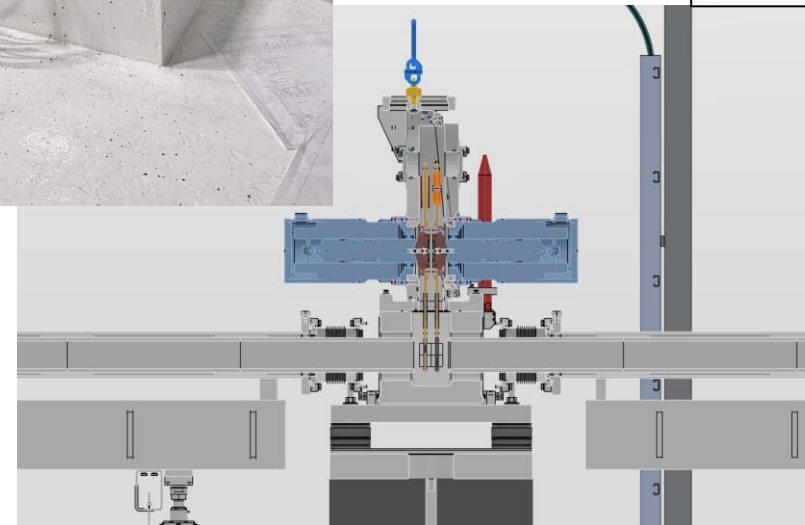
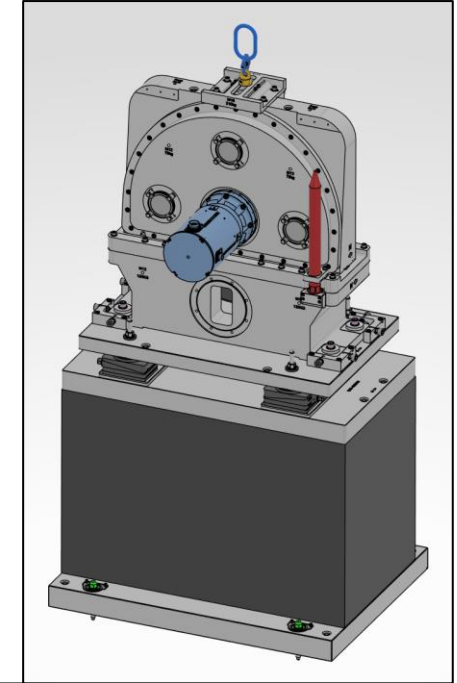

BEER – Hereon

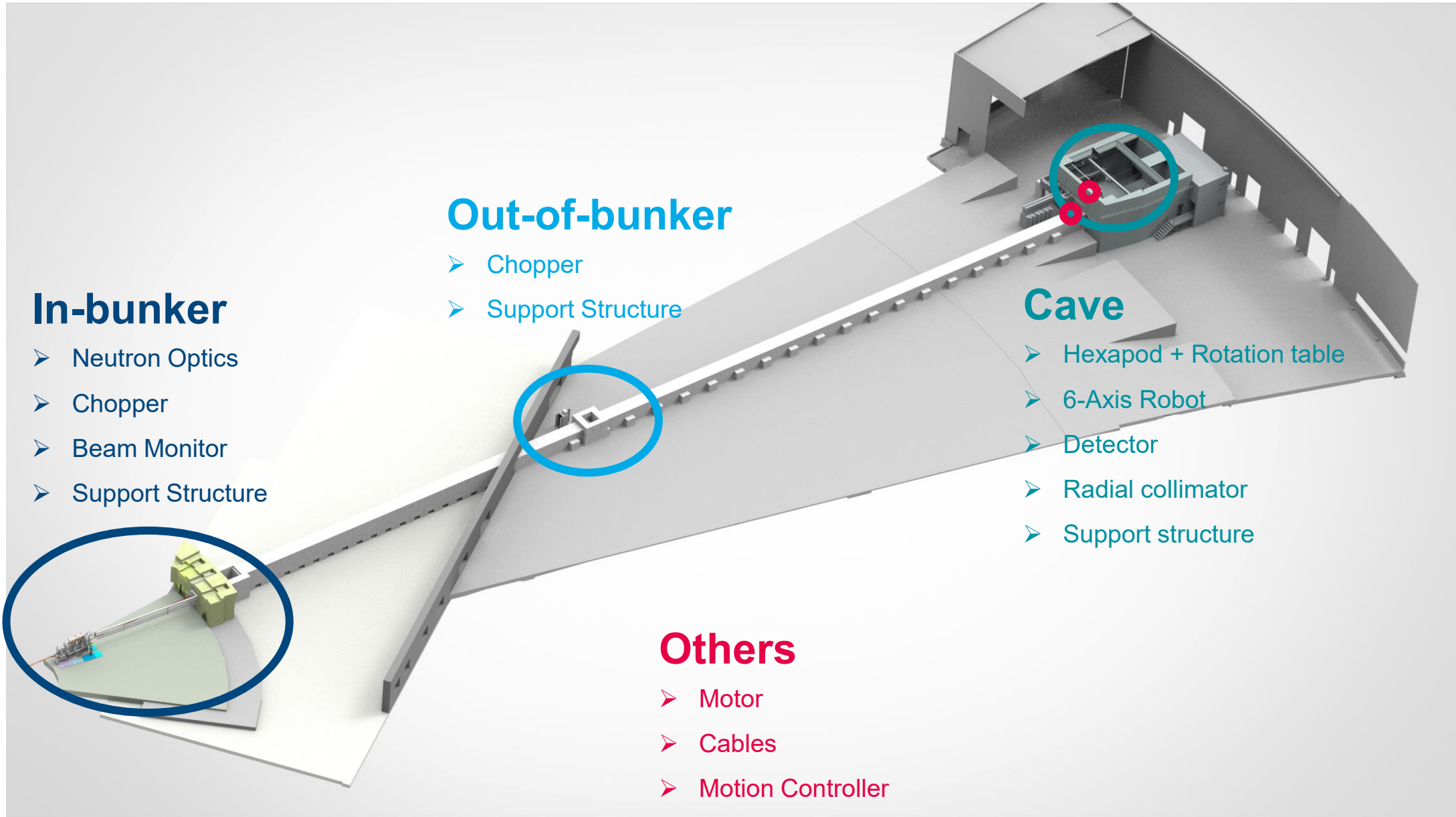

In-bunker

- Neutron Optics
- Chopper
- Beam Monitor
- Support Structure

Out-of-bunker

- Chopper
- Support Structure

Cave

- Hexapod + Rotation table
- 6-Axis Robot
- Detector
- Radial collimator
- Support structure

Others

- Motor
- Cables
- Motion Controller

Cave parts

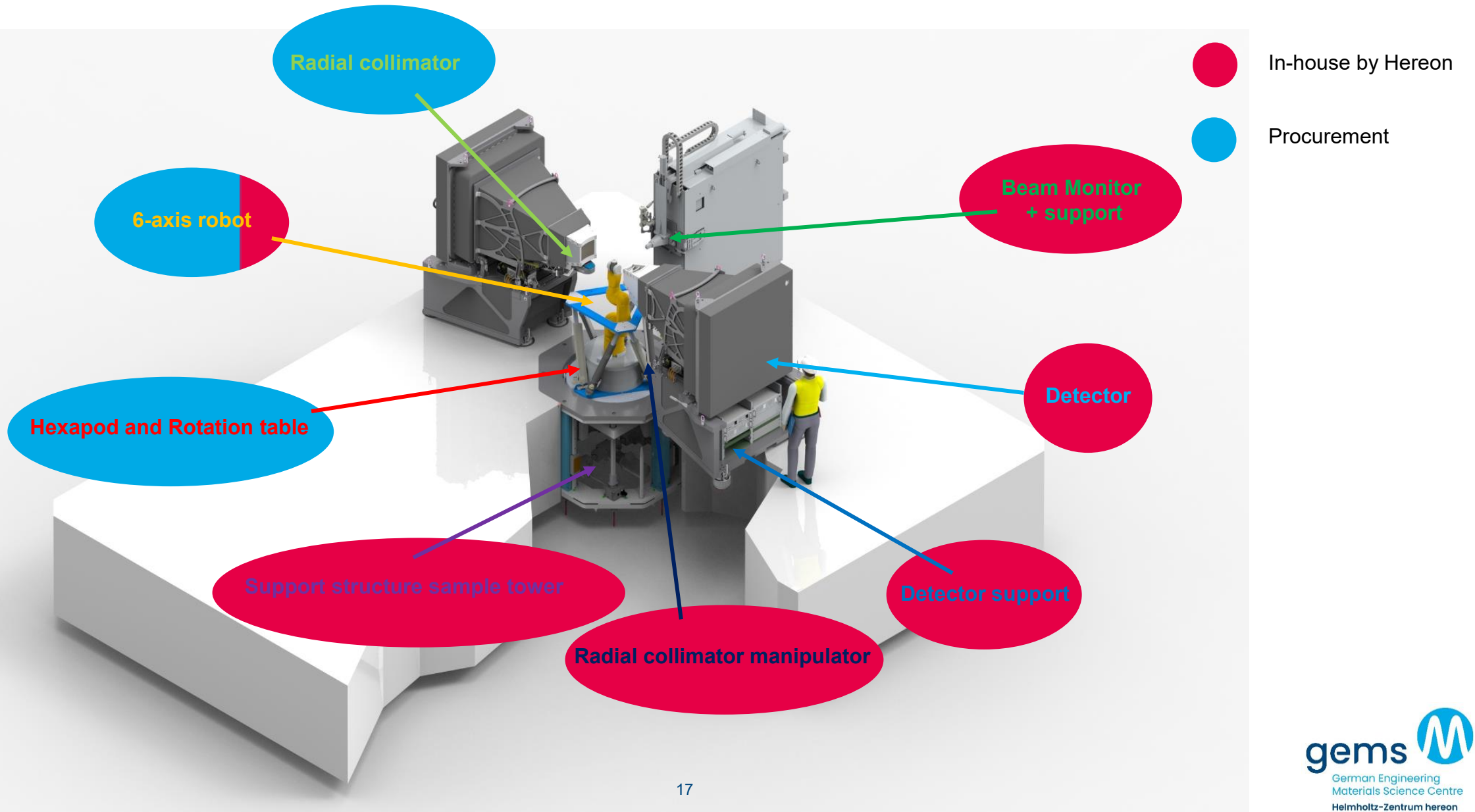

Cave parts – design and process status

Hexapod + Rotation table

✓ PDR



✓ CDR



✓ Manufacturing finished



✓ Shipment



Installation after installation of support structure

Supplier:

Symetrie

Issues/Risks:

- Control integration
- Installation after Cave fit out

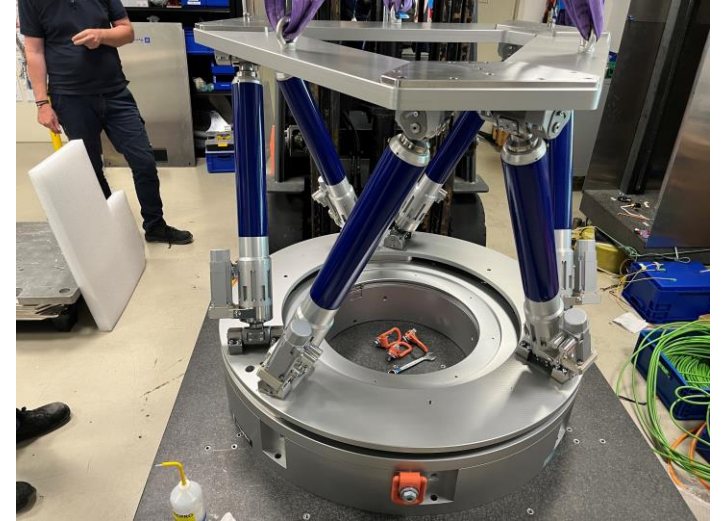

Cave parts – design and process status

6- Axis Robot

✓ CDR



✓ Manufacturing finished



Shipment tbd



Installation after installation of support structure

Supplier:

Stäubli

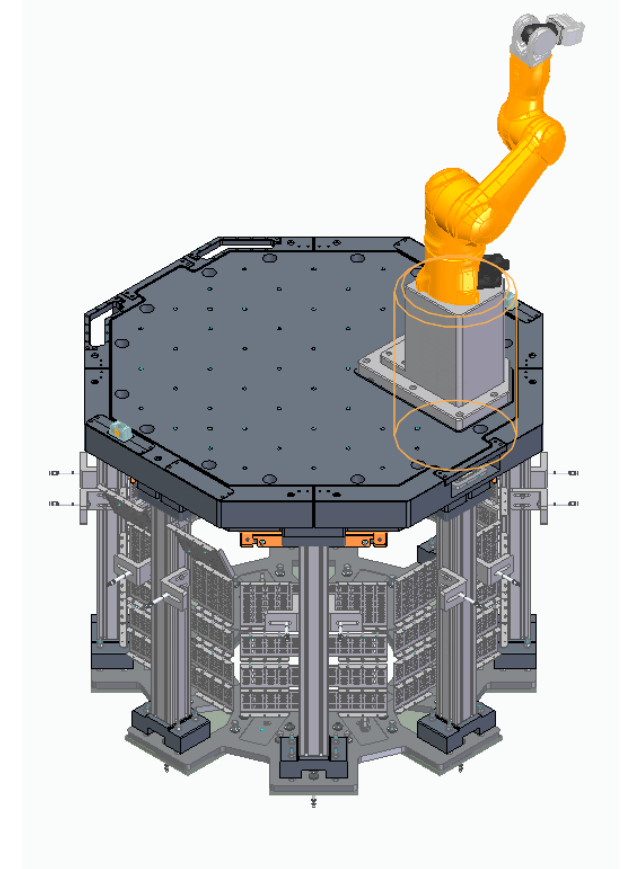

Issues/Risks:

- Control integration

Cave parts – design and process status

Support structure sample tower

✓ PDR

↓
CDR June/July 2026

↓
Manufacturing on going

↓
Shipment August 2026

↓
Installation August 2026

Supplier:

Hereon

Issues/Risks:

- none

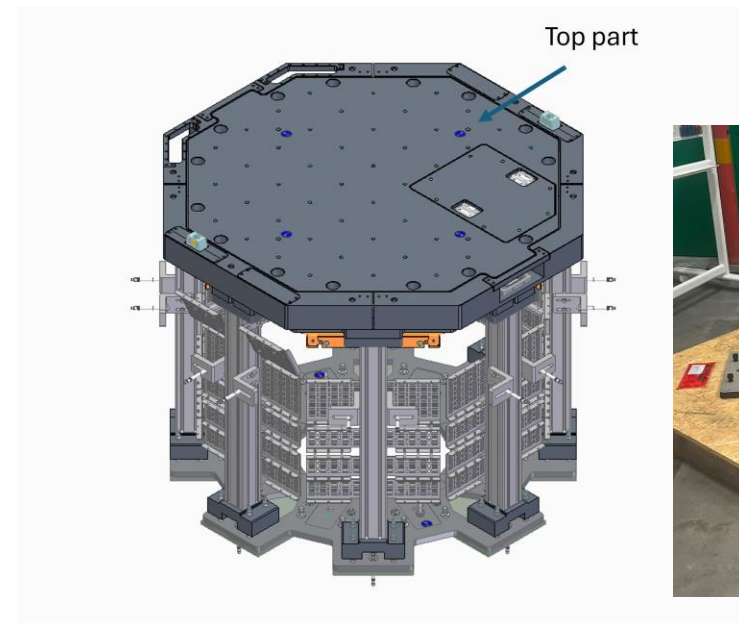
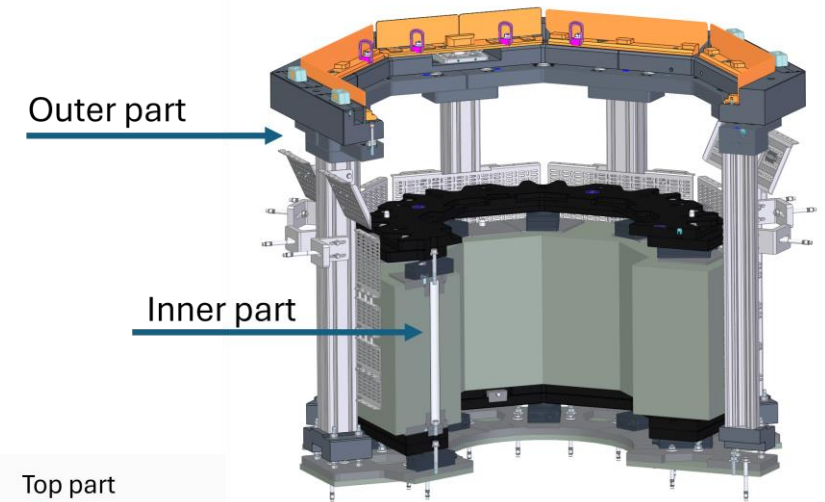

Cave parts – design and process status

Detector + read-out + Beam Monitors

✓ CDR



Manufacturing finished Qongoing



Shipment tbd



Installation tbd

Supplier:

Hereon

Issues/Risks:

- Proof at other neutron sources

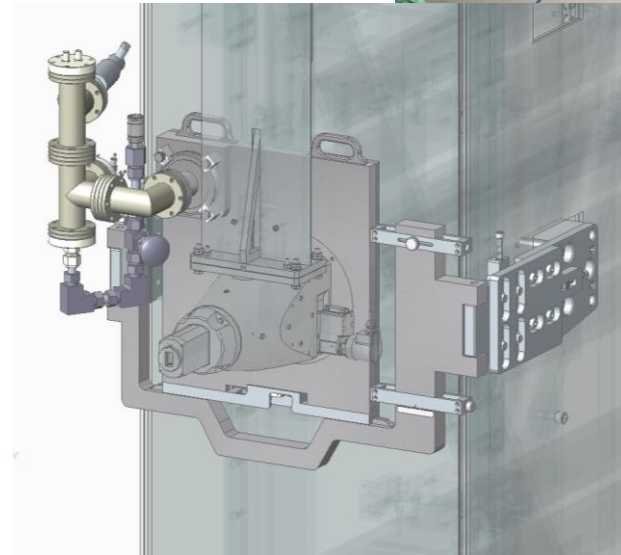
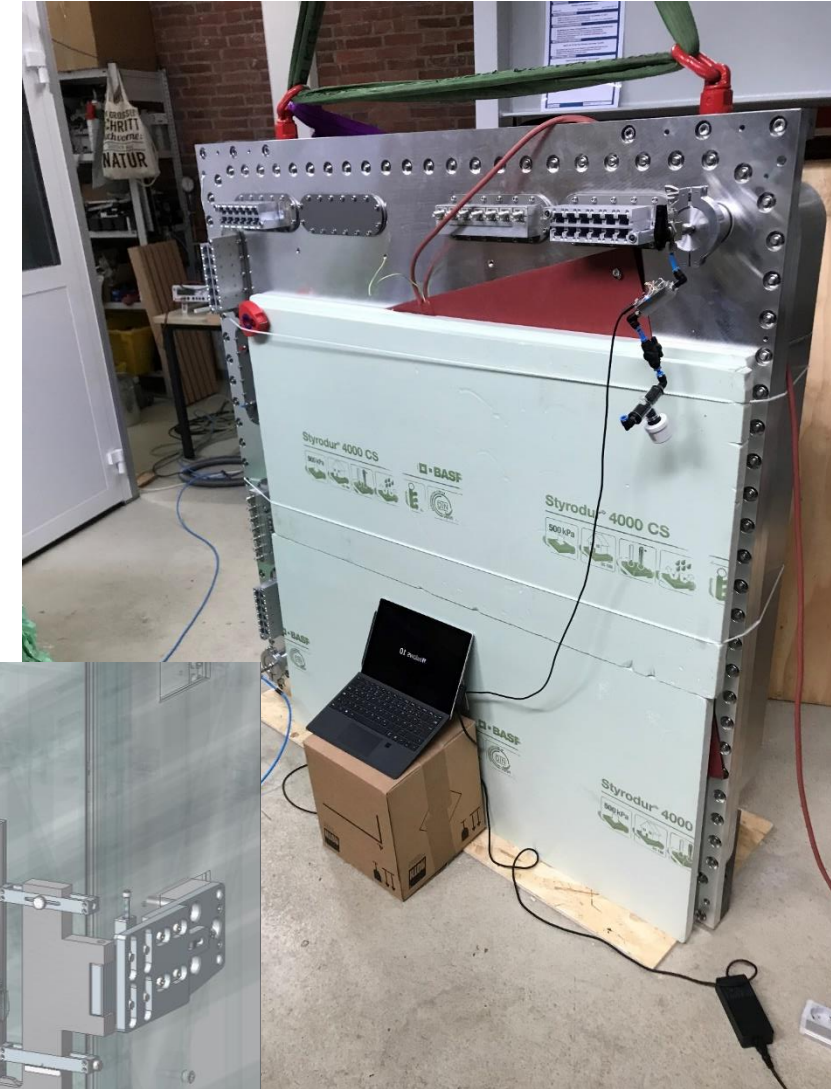

Cave parts – design and process status

Detector support

CDR Q3 2026



Manufacturing finished Q4 2026



Shipment Q4 2026



Installation Q4 2026

Supplier:

Hereon

Issues/Risks:

- Schedule

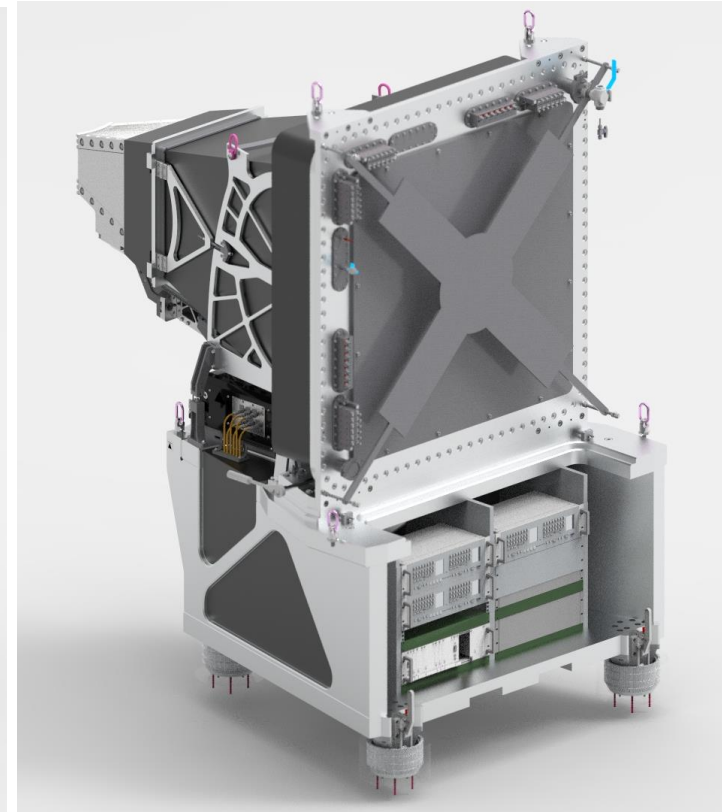
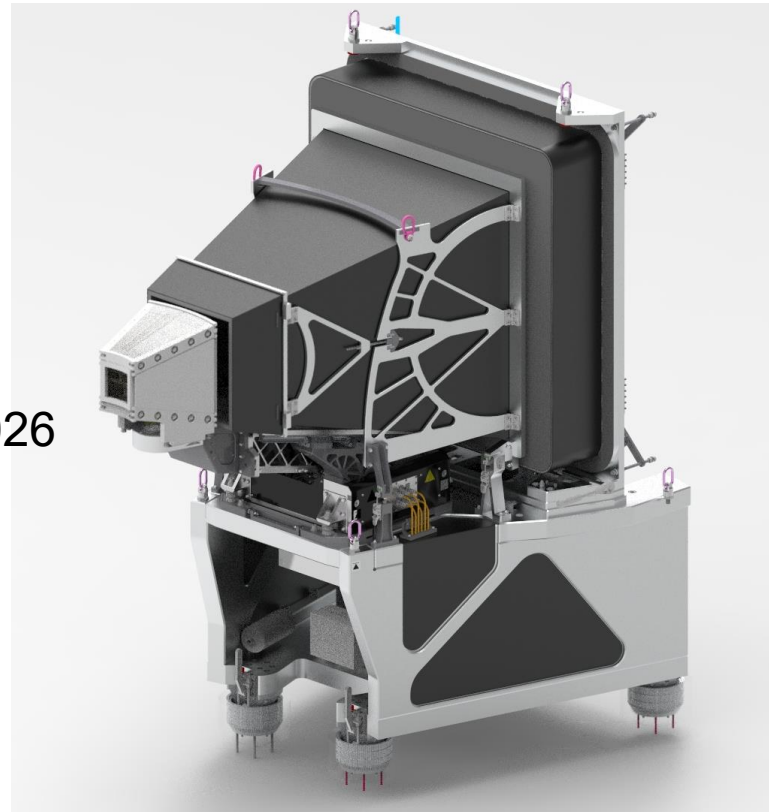

Cave parts – design and process status

Radial collimators

✓ PDR



✓ CDR



✓ Manufacturing finished



✓ Shipment



Installation after installation of detector support

Supplier:

JJ-Xray

Issues/Risks:

- Long term storage before installation

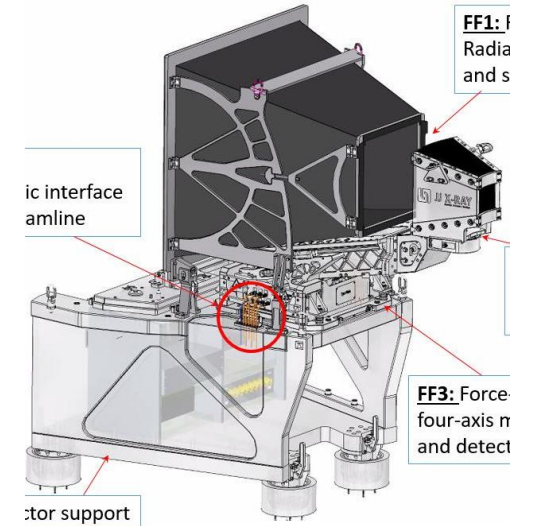

Cave parts – design and process status

Radial Collimator manipulator

✓ PDR



✓ CDR



✓ Manufacturing finished



Shipment tbd



Installation after installation of detector support

Supplier:

Hereon

Issues/Risks:

- None

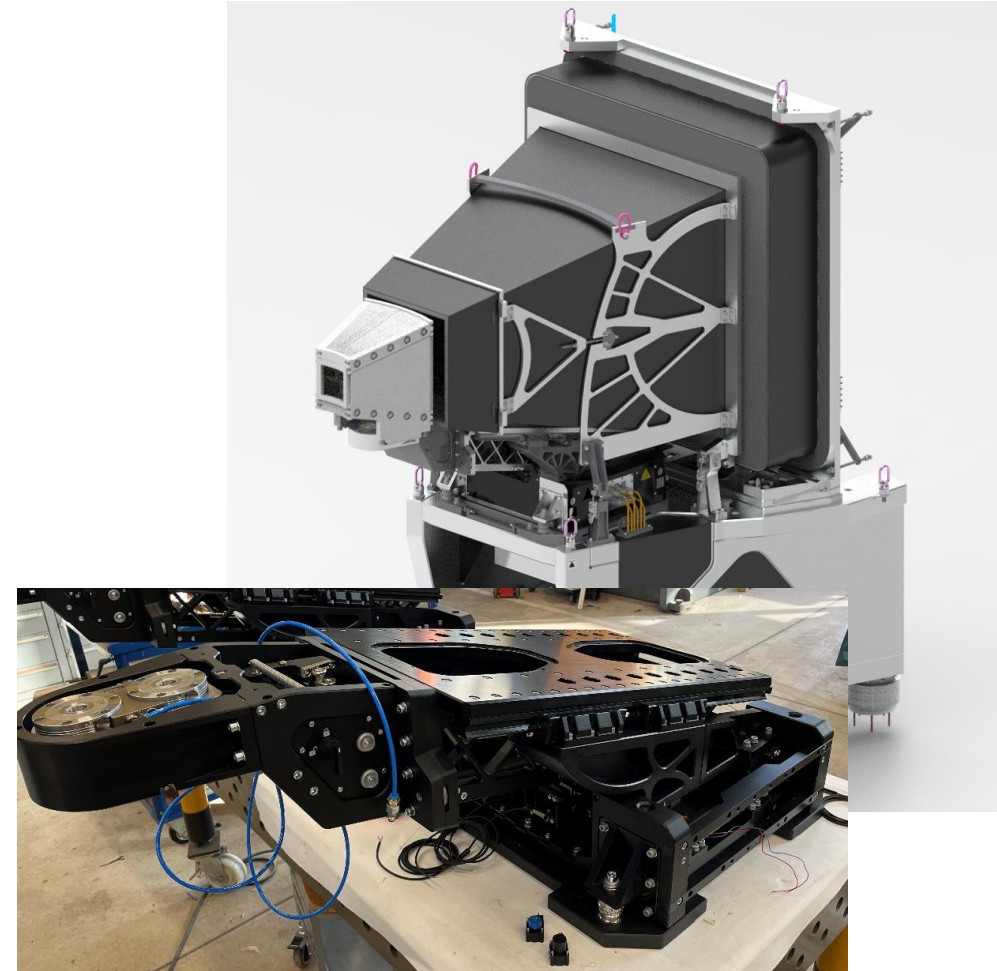

Thank You

