



# Scientific Hot Commissioning Plan

ESTIA

PRESENTED BY GRACE CAUSER

2026-06-12



Document Type Validation Plan  
 Document Number ESS-0318499  
 Date Jun 9, 2026  
 Revision 2(1/1)  
 State Draft  
 Confidentiality Level Internal  
 Page 1 (25)

VW Plan is still in Review

## ESTIA - System Verification and Validation Plan

	Name	Role/Title
<b>Owner</b>	Joshaniel Cooper	ESTIA Lead Scientist
<b>Author</b>	Felipe Lopes da Silva Grace Causer Joshaniel Cooper	ESTIA instrument operations engineer ESTIA instrument Scientist ESTIA Lead instrument Scientist
<b>Reviewer</b>	Giuseppe Aprigliano Per Roos Helen Boyer Hanna Wacklin-Knecht Torben Roland Nielsen Fredrik Bolmsten Nikolaos Tsapatsaris Vincent Hardion Thomas Gahl Francesco Piscitelli	NSS Engineering Radiation Protection Group Leader Occupational Health and Safety Group Leader Head Scientific Support Division Group Leader for Data Reduction, Analysis, and Modelling Group Leader for Scientific Information Management Systems Neutron Chopper Group Leader Experiment Control and Data Curation Group Leader Motion Control Group Leader Detector Scientist (representing Detector Group)
<b>Approver</b>	Andrew Jackson Rob Connatser	Head of Large Scale Structures Division NSS Sub-Project Leader

S Tag	Description	FAT reports	SAT reports	Integrated test reports
ESS.NSS.H01.ESTIA	ESTIA		N/A	
ESS.NSS.H01.ESTIA.A04	Support Systems	N/A	<a href="#">ESS-5702797</a>	
ESS.NSS.H01.ESTIA.A04.A01	Control Hutch	N/A	<a href="#">ESS-5244754</a>	
ESS.NSS.H01.ESTIA.A04.A03	Support infrastructure		N/A	
ESS.NSS.H01.ESTIA.A04.P01	Remote Area Surveillance		N/A	
ESS.NSS.H01.ESTIA.A04.GM01	Local Crane	<a href="#">ESS-5827044</a>	N/A	
ESS.NSS.H01.ESTIA.A04.F01	Fire Protection		N/A	
ESS.NSS.H01.ESTIA.A04.A02	Sample Preparation Facility		N/A	
ESS.NSS.H01.ESTIA.A05	Supply Systems		N/A	
ESS.NSS.H01.ESTIA.A05.W01	Electrical Power & Grounding	N/A	<a href="#">ESS-5145870</a>	
ESS.NSS.H01.ESTIA.A05.K01	Timing system		N/A	
ESS.NSS.H01.ESTIA.A05.W02	Process Utilities	N/A	<a href="#">ESS-5855523</a>	
ESS.NSS.H01.ESTIA.A05.Q01	Gas mixing system – beam monitors	N/A		
ESS.NSS.H01.ESTIA.A05.Q02	Gas mixing system – detectors	N/A		
ESS.NSS.H01.ESTIA.A01	Beam Transport and Conditioning	See sub nodes below	See sub nodes below	See sub nodes below
ESS.NSS.H01.ESTIA.A01.R01	ESTIA Chopper System	<a href="#">ESS-4977986</a>	<a href="#">ESS-5912344</a>	<a href="#">ESS-6014560</a>
		<a href="#">ESS-4046901</a>	<a href="#">ESS-5865963</a>	
		<a href="#">ESS-5010822</a>	<a href="#">ESS-5520853</a>	
ESS.NSS.H01.ESTIA.A01.R02	Beam Geometry Conditioning	N/A see below	N/A (see below)	<a href="#">ESS-6044516</a>
ESS.NSS.H01.ESTIA.A01.R02.R01	Virtual Source (VS)	<a href="#">ESS-5164456</a>	<a href="#">ESS-5402693</a>	
			<a href="#">ESS-6004915</a>	
ESS.NSS.H01.ESTIA.A01.R02.R02	Middle Focus (MF)	<a href="#">ESS-5819512</a>	<a href="#">ESS-5491461</a>	
		<a href="#">ESS-5304267</a>		
		<a href="#">ESS-5305492</a>		
		<a href="#">ESS-5305509</a>	<a href="#">ESS-6005442</a>	
<a href="#">ESS-5341933</a>				
		<a href="#">ESS-5362739</a>		

# Hot Commissioning

## Overview of Tasks



- Fulfil radiation protection requirement
- Flux and beam profiles
  - Beam Monitor*
  - Selene Guide Alignment*
  - Beam Profile & Background*
- Chopper
- Motion components
  - Sample positioning system*
  - Virtual source*
  - Divergence slit*
  - Dectector positioning*
  - Polariser and FOM*
- Flight-path calibration
- Detector calibration and angle verification
- Polarisation efficiency
- Demonstration experiments



### High Level Scientific Requirements

ESTIA Concept of Operations (ESS-0103155)

**Many steps will be repeated multiple times during beam ramp-up**

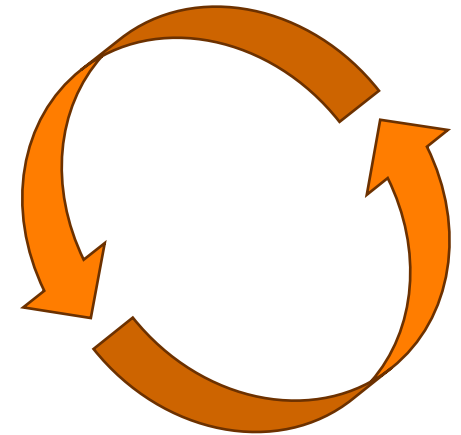

### Concept of Operations (ESS-0103155)

- $q_z$  range from  $0.005 \text{ \AA}^{-1}$  up to  $1 \text{ \AA}^{-1}$
- Measure samples between  $1 \times 1 \text{ mm}^2$  -  $10 \times 10 \text{ mm}^2$
- neutron polarization analysis with polarizations  $>95\%$
- Typical relative resolution of  $\sigma_{q_z}/q_z \leq 2.5\%$
- Controllable beam size at the sample position
- Measurement of off-specular and GI-SANS
- ...

# Fulfil radiation protection requirements

Demonstrate the performance of the shielding to the licensing authority



## 1. Instrument shutter

instrument shutter closed → check radiation levels at various locations

→ repeat checks before/after guide alignment & each time proton current is increased  
(ESS-6056497) (ESS-0432926) (ESS-6014372) (ESS-5146219)

## 2. Cave shielding

instrument shutter open → check radiation levels outside the cave (e.g., cave door and penetrations)

→ verify cave shielding according to H1/H2 scenarios (ESS-0432926)

## Checkpoint

Dose measured outside → bunker, guide shielding and cave is  $<3 \mu\text{Sv/h}$  (ESS-0239718)

→ cave roof is  $<25 \mu\text{Sv/h}$

*Key personnel: RP, PSS, ESTIA instrument team.*

*Requirements: Chopper parked open. Accelerator stable enough for the duration of each test.*

# Flux and beam profiles

## 1. Beam Monitor

### 1. Flux profiles

- Calibrated against Au-foil measurements performed at
  - middle focus
  - sample position

to determine approximate fluxes at the VS.

- Time structure and intensity of neutron pulse will be compared to simulations.

### 2. Stability

The BM count rate will be compared to the proton beam current in ~15-minute intervals

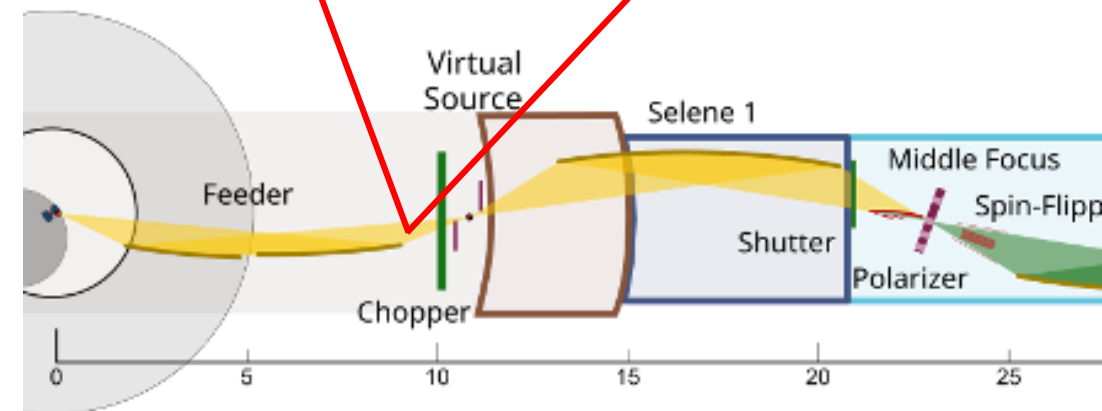
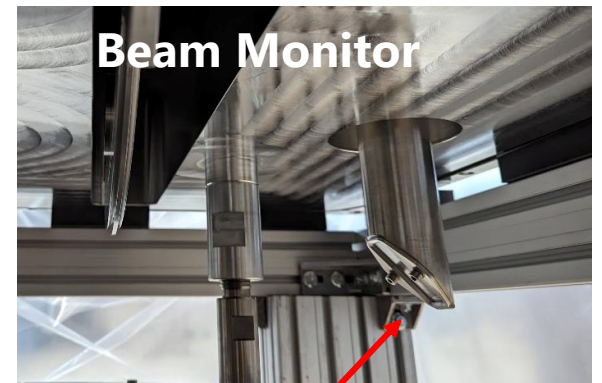

*Key personnel: ESTIA instrument team, detG, DMSC, ECDC, RP for the Au-foil measurements.  
Requirements: Data pipeline from monitors/detectors to data reduction in place. Sufficiently powerful and stable beam.*

# Flux and beam profiles

## 2. Selene Guide Alignment

### 1. SG1

Optimise alignment → small VS + MF scintillator

→ move each vertical/horizontal mirror segment to verify contribution  
(to increase flux, relaxed beam focus is used in the non-aligning direction)

### 2. SG1 Carrier

Optimise focal point → translate the entire SG1 carrier in Y/Z (engineer. coords) to move the focal point to the MF

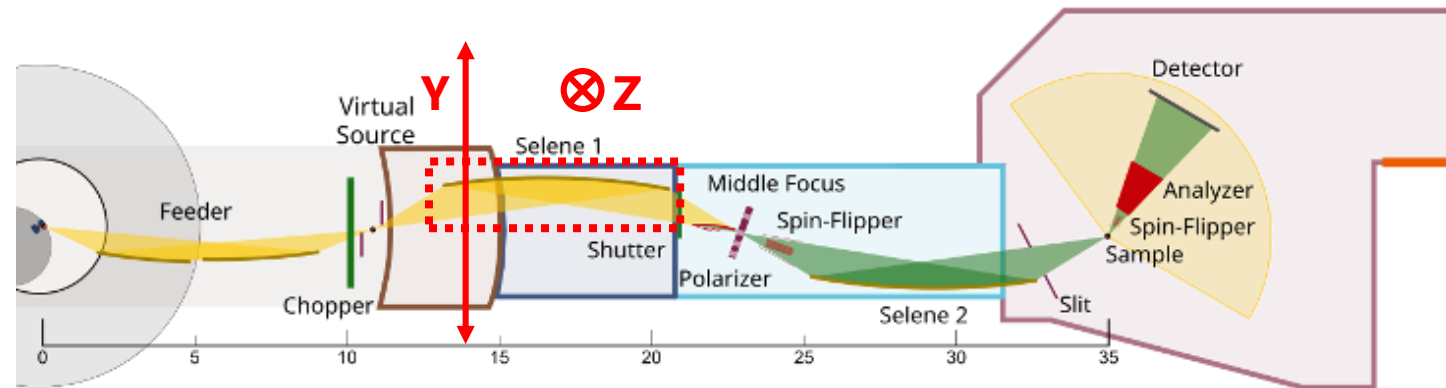

Key personnel: ESTIA instrument team, detG, DMSC, ECDC.

> 100 kW

Requirements: Data pipeline from monitors/detectors to data reduction in place. Sufficiently powerful and stable beam.

# Flux and beam profiles

## 2. Selene Guide Alignment

### 3. SG2

Optimise alignment → fully open VS + MF slit + imaging detector at sample position

→ move each vertical/horizontal mirror segment to verify contribution

→ translate the entire SG2 carrier to move the focal point to the sample position

Fine adjustment → double-gradient ML measurements (ESS-0414834)

→ analyse different detector sectors to obtain divergence-dependent beam offset profile

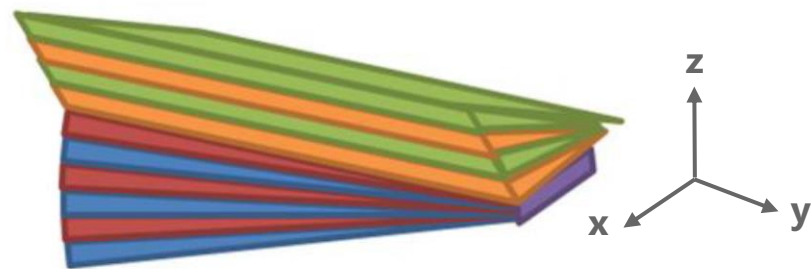

Schematic of the double gradient Ni/Ti ML

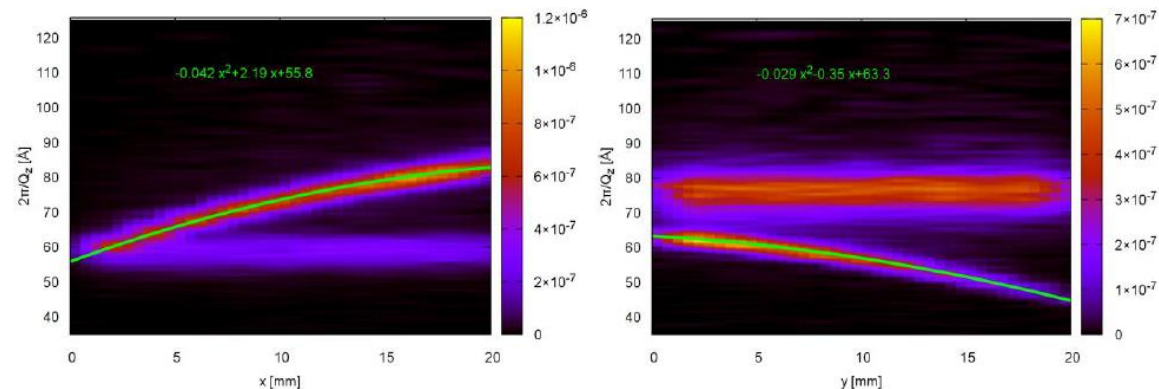

Key personnel: ESTIA instrument team, detG, DMSC, ECDC.

Requirements: Data pipeline from monitors/detectors to data reduction in place. Sufficiently powerful and stable beam.

> 100 kW

# Flux and beam profiles

## 2. Selene Guide Alignment

### 3. SG1

Fine adjustment → small VS + MF no slit

→ double-gradient ML measurements

→ analyse different detector sectors to obtain divergence-dependent beam offset profile

→ verify full divergence is transported through the guide to the detector

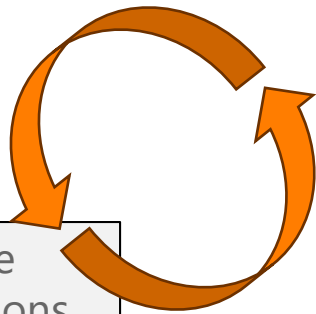

This will be a highly iterative process, involving comparisons to simulations

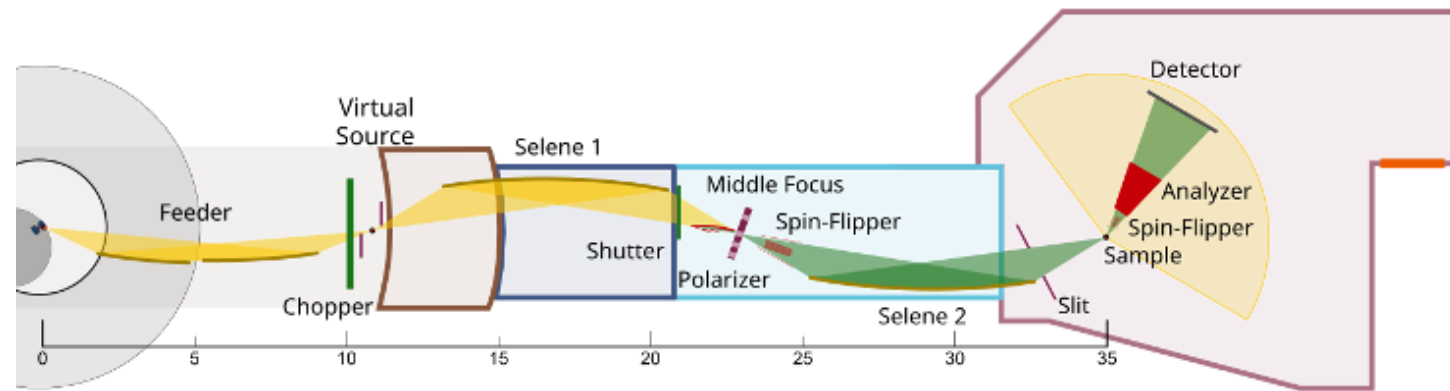

Key personnel: ESTIA instrument team, detG, DMSC, ECDC.

> 100 kW

Requirements: Data pipeline from monitors/detectors to data reduction in place. Sufficiently powerful and stable beam.

# Flux and beam profiles

## 3. Beam Profile

1. Beam profile will be imaged at the:

MF → camera & scintillator setup

Sample position → imaging camera & double-gradient ML to verify the beam shape and re-align SGs as needed.

2. Verify polarizer and FOM do not distort the beam.

3. Verify the sample slit can control the divergence without affecting the beam shape.

- Results will be compared to McStas simulations.

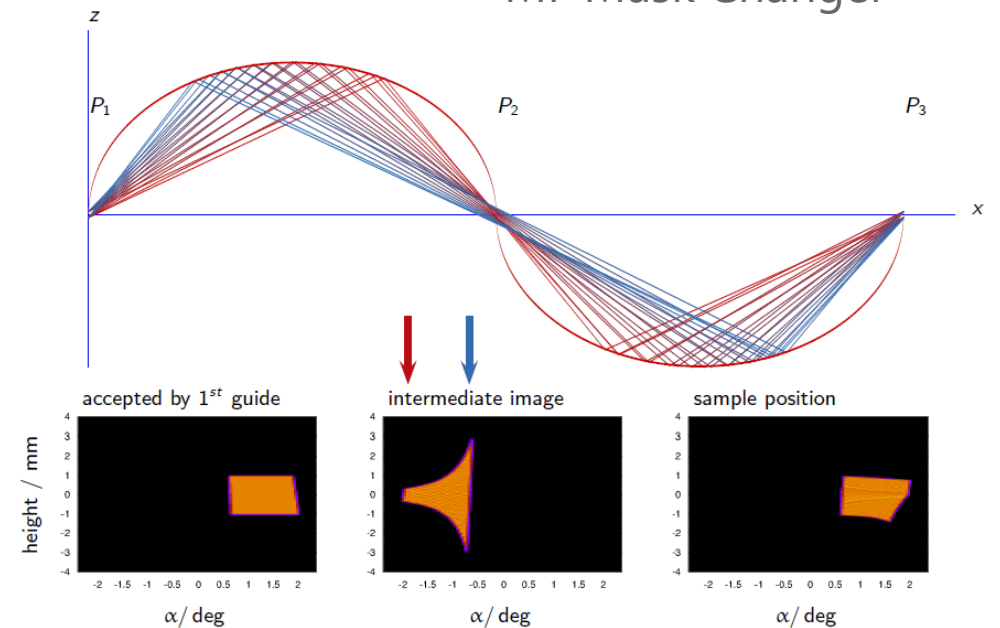
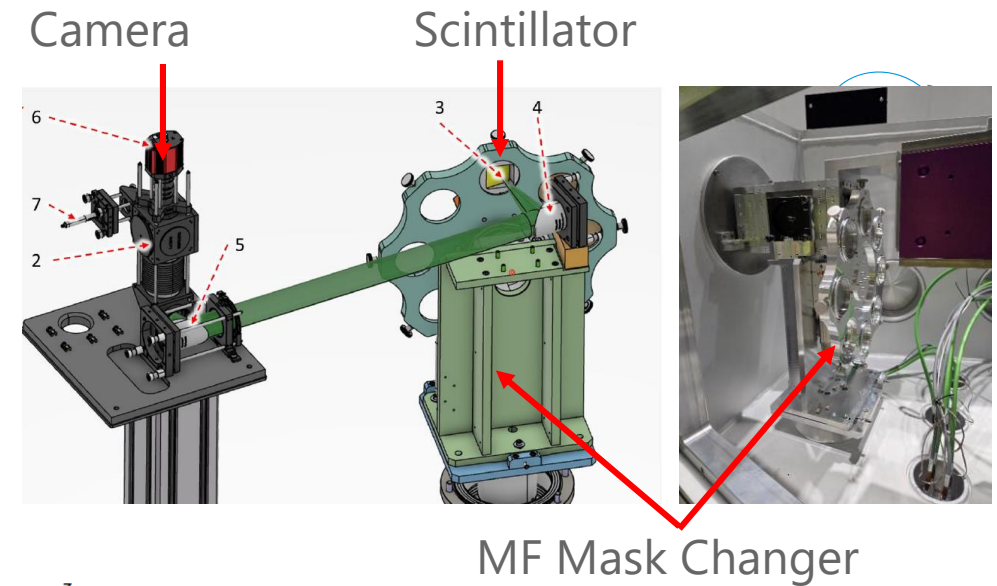

*Key personnel: ESTIA instrument team, detG, DMSC, ECDC.*

*Requirements: Data pipeline from monitors/detectors to data reduction in place. Sufficiently powerful and stable beam.*



# Flux and beam profiles

## 4. Background

Background measured on the detector in all instrument conditions

1. Beam off (instrument shutter closed)
2. Beam on + no sample
3. Beam on + sample (water)
4. Beam on + sample (cadmium)
5. Beam on + sample environments
6. Beam on + different beam sizes
7. Beam on + different detector arm positions
8. Source off
9. Source off (longer period)

Eliminate background sources using masks at the detector arm entrance and/or absorbers around sources traced back to e.g., the cave wall.

*Key personnel: ESTIA instrument team.*

*Requirements: Sufficiently powerful and stable beam.*

# Chopper

## 14 Hz bandwidth chopper

1. Confirm chopper can be parked open/closed
2. Confirm chopper speed and the neutrons on the detector have the same frequency
3. Using Si(111) reflection, measure wavelength spread of beam to verify cutoff wavelength at the low- $\lambda$  end corresponds to the minimum  $\lambda$  set by the chopper phase. Fine tune chopper phase offset.
4. Phase the chopper, such that the cutoff from the SGs is just outside the opening window of the chopper
5. Confirm the bandwidths, and the exact min/max  $\lambda$ 's for the 14, 14/2 and 14/3 operations

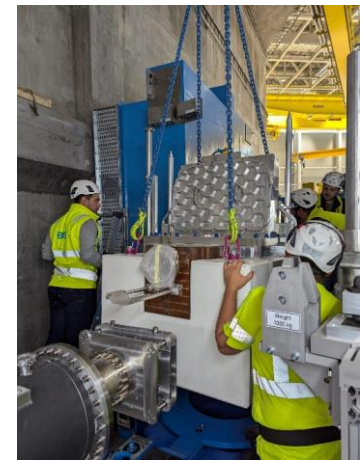
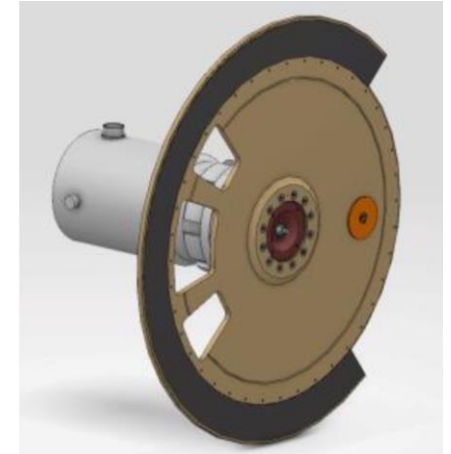
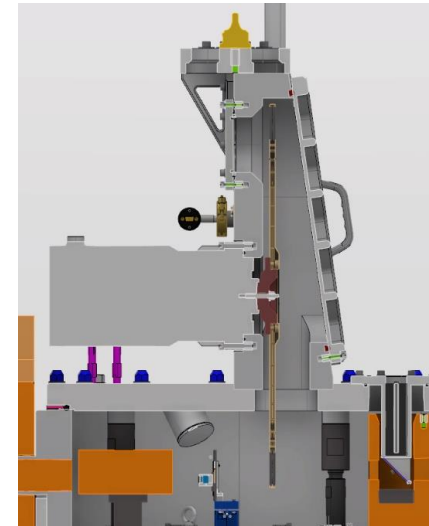

*Key personnel: ESTIA instrument team, chopper group, ECDC.  
Requirements: Sufficiently powerful and stable beam. Pulse length as by design.*

# Motion components

## 1. Sample Positioning System

Confirm:

- Neutron beam (center) passes through the sample position
- Centre of rotation of motion axes ( $R_x$ ,  $R_y$ ,  $R_z$ ) are aligned to the beam center and sample position
- Sample alignment can be done for any incident angle ( $\pm \omega$ ) with sample maintaining optimal position
- Sample remains aligned when counter rotation of the sample stage and hexapod  $R_z$  are used

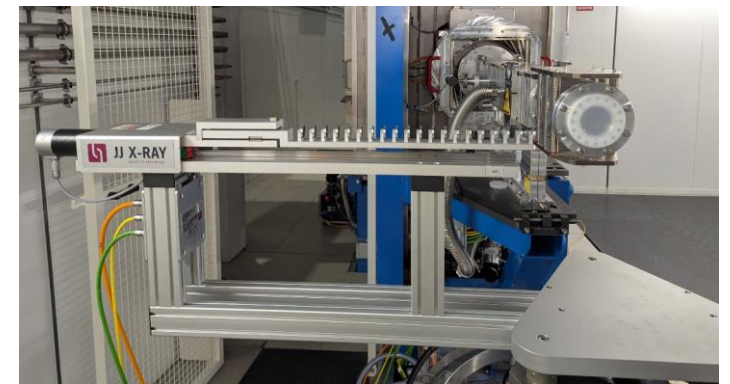
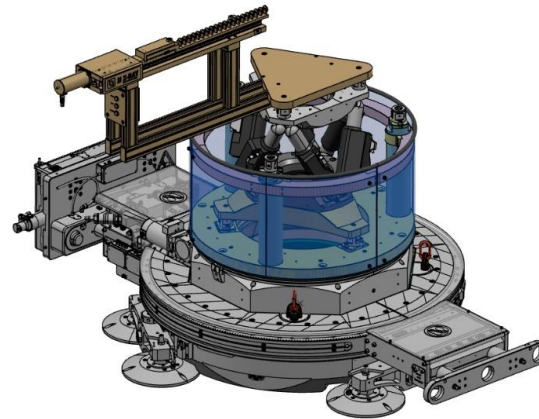
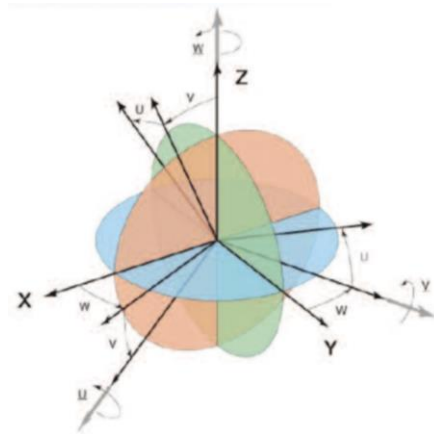

*Key personnel: ESTIA instrument team, motion control group, ECDC.  
Requirements: Standard samples for reflectometry calibration.*

# Motion components

## 2. Virtual Source

Validate:

- Zero-opening position by scanning vertical and rotation motors with the detector in the forward position (DB)
- X-position of the VS by measuring the rotation zero for different horizontal openings

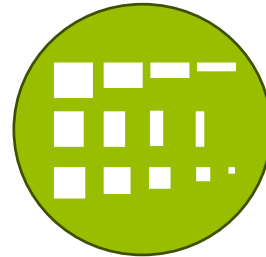

Schematic of positioning wafer

Repeatability tests of VS positioning:

- Lithographically-patterned wafer, move the VS to different sizes back/forth
- Confirm constant footprint for different  $\omega$ ; co-rotating VS + positioning wafer

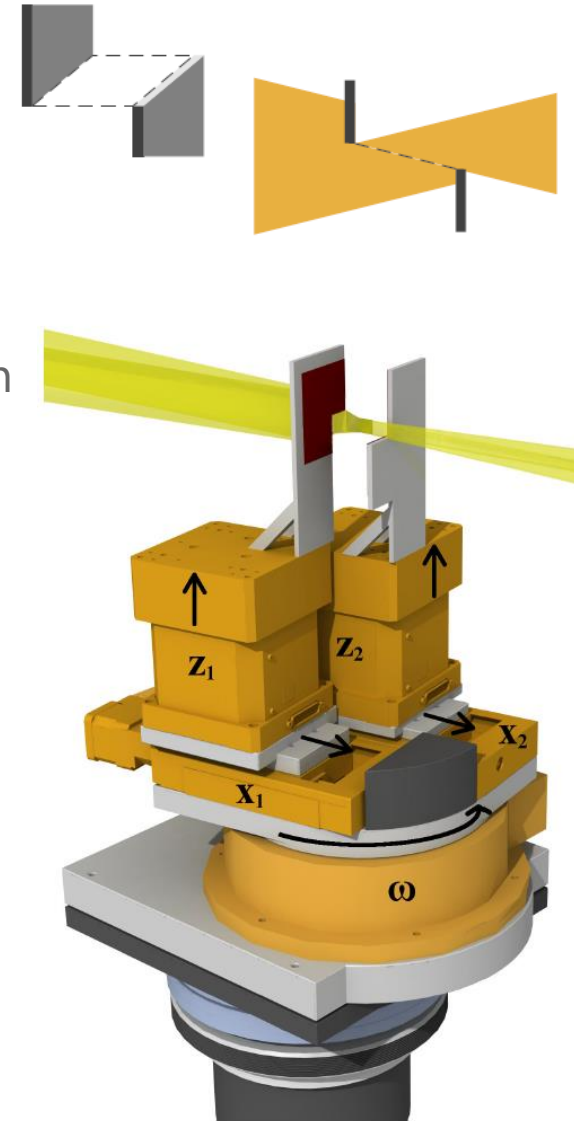

*Key personnel: ESTIA instrument team, motion control group, ECDC.  
Requirements: Standard samples for reflectometry calibration.*

# Motion components



## 3. Sample Slit

The sample slit will be validated in the same way as the VS:

- Different footprint sizes
- Different incident angles

For both collimated and divergent modes.

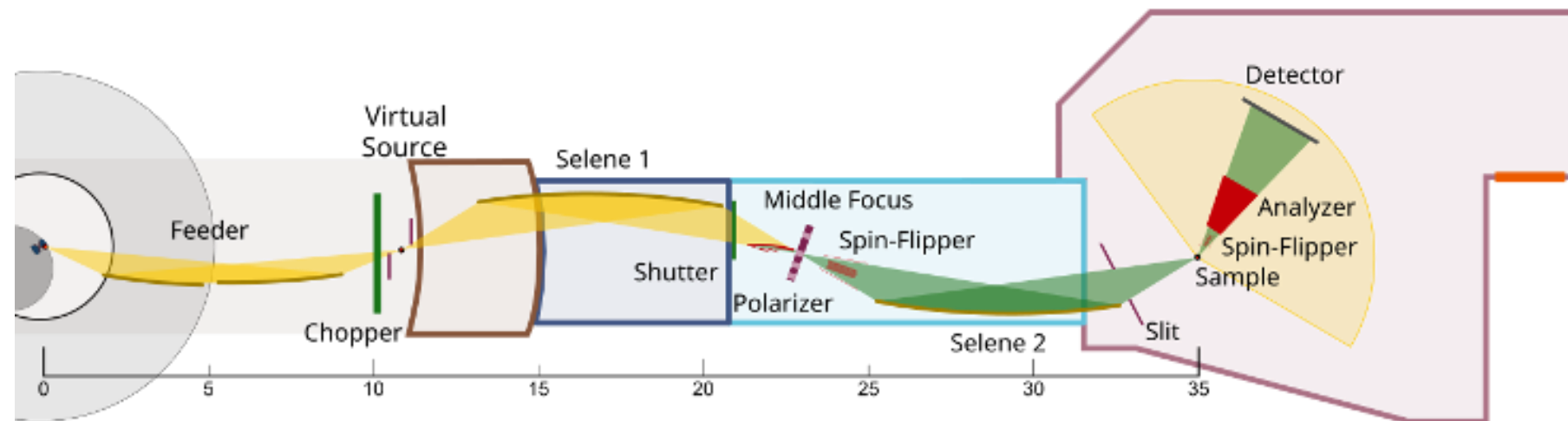

*Key personnel: ESTIA instrument team, motion control group, ECDC.  
Requirements: Standard samples for reflectometry calibration.*

# Motion components



## 4. Detector Positioning

Detector position wrt moderator → calibrated using a diffraction standard (graphite) for flight path calibration

Detector position wrt neutron beam → validated by ensuring RB remains at same detector pixel for different sample  $\omega$

Detector blade geometry → calibrated by scanning collimated beam reflection over detector (at fixed  $2\theta$ ) for different sample  $\omega$

Calib. Sample #1: Grating producing lines of constant  $Q_x$   
     $Q_x$  vs  $Q_z$  map: equally spaced vertical  $Q_x$  lines  
    Otherwise; incorrect geometry, wavelength or data reduction

Calib. Sample #2: Sample producing Bragg sheets across detector  
     $\pi$ - $\rho$  vs  $Q_z$  map: horizontal Bragg sheets  
    Otherwise; incorrect geometry

Vertical pixel positions → scan across detector using a collimated beam to verify all blades are aligned.

*Key personnel: ESTIA instrument team, motion control group, ECDC.*

*Requirements: Standard samples for specular and off-specular reflectometry calibration.*

# Motion components

## 4. Polariser and FOM

- Logarithmic spiral devices will be aligned to the beam using the  $\lambda$  cutoffs of the device
- Manufacturer measurements for comparison

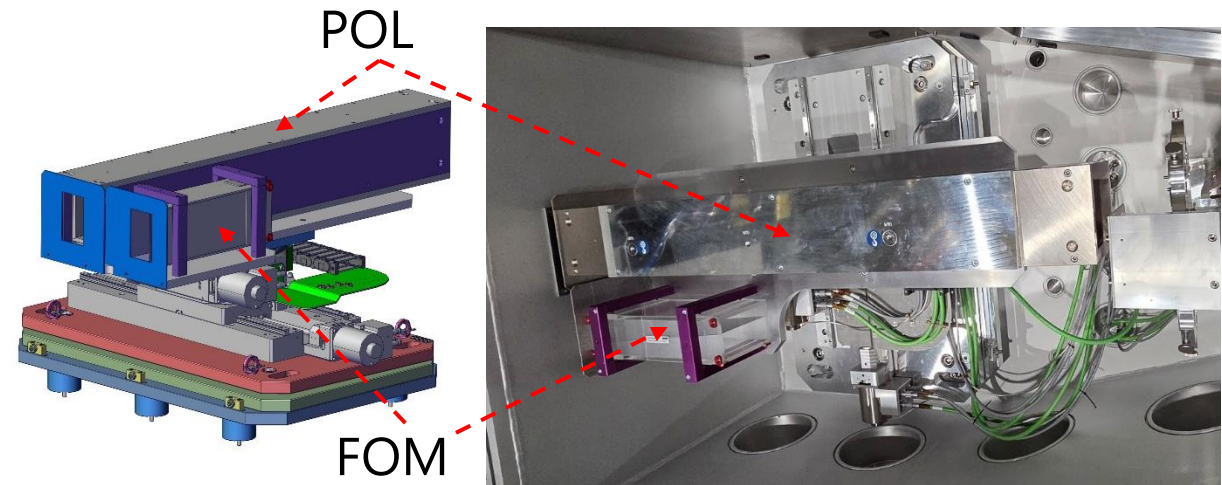

*Key personnel: ESTIA instrument team, motion control group, ECDC.  
Requirements: Standard samples for off-specular reflectometry.*

# Detector Calibration



## Multi-Blade detector

**Data Reduction:** Measurement of a collimated DB and supermirror RB will be used to verify correct treatment of data events.

**Detector Resolution and Homogeneity:** Absorbing masks will be used to determine the resolution of detector pixels. Glassy carbon will be used to determine pixel-to-pixel efficiency. Different detector angles will be measured to confirm no unexpected angle-dependent inhomogeneity.

**Detector Noise and Gamma Suppression:** Noise measured with beam on + instrument shutter closed. Measured noise compared to 'dark counts' recorded during cold commissioning. A selectivity to gamma rays will be calibrated by taking a measurement of the beam, then inserting a sample at the sample point which will absorb all the neutrons and convert them to gamma rays. A measurement will be then taken of how many gamma rays are incorrectly ascribed as neutrons.

*Key personnel: ESTIA instrument team, detG, ECDC.*

*Requirements: Data acquisition stream tested with simulated and test data. Glassy carbon.*

# Polarisation

## Transmission polarizing supermirror



### Polarising Power and Flipper Efficiency:

- A calibrated polarising SM will be measured to determine the polarising power and flipper efficiency of the beamline.
- Measurements will be taken with the saturated polarising SM and a non-depolarising SM.
- Polarisation corrections will be determined using workflows written in Scipp.
- Corrections will be applied to all future experimental data.

**Target:** >95% polarization over the wavelength and divergence range.

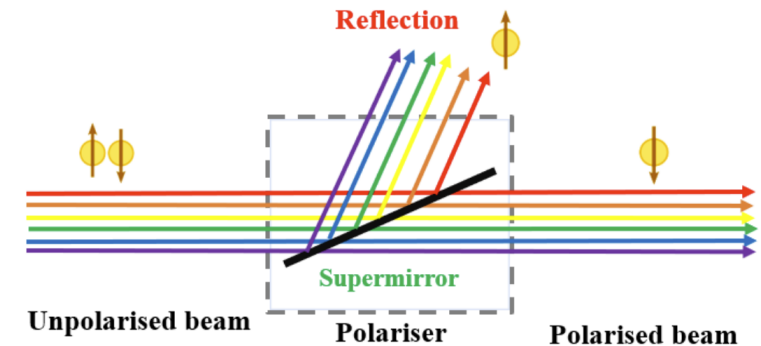

*Key personnel: ESTIA instrument team, ECDC.*

*Requirements: Data acquisition stream tested with simulated and test data. Analyser.*

# Demonstration Experiments

## Benchmarking and First Science

- Used to verify the compatibility of various SE's and the performance of the instrument compared to other state-of-the-art instruments around the world.
- Standard samples and samples from friendly users
- ESTIA Early Science Workshop was conducted December 2025. 43 participants
- Breakout Sessions:
  - Magnetism
  - Biology
  - Functional Materials

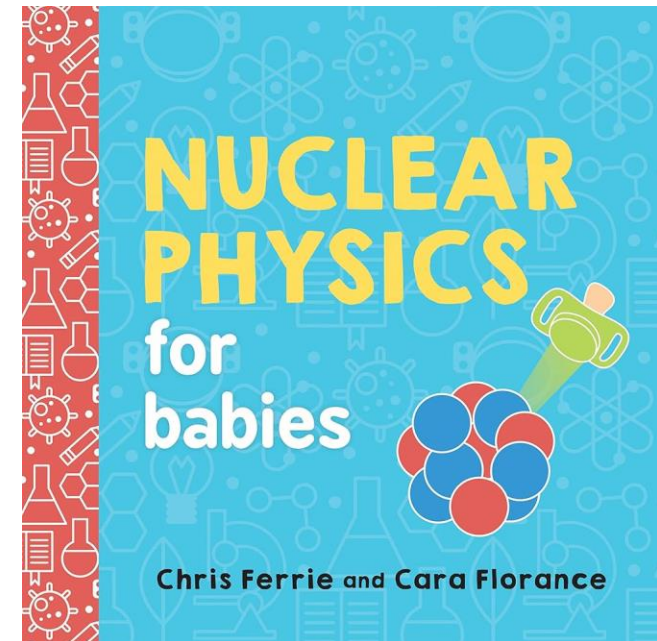

*Key personnel: ESTIA instrument team, sample environment group, ECDC*

*Requirements: Calibrated instrument, data reduction chain in place, sample, stable and intense enough neutron beam.*



# Time Planning

## Hot Commissioning

Task	Expected Duration (days)	Comments
Fulfil radiation protection requirements	5	Hold point before any further step can begin. Need to repeat if neutronic alignment and commissioning increases flux.
Check neutron beam profile	28	Requires beam power > 100kW for aligning SGs. No further tests can be done without this complete.
Chopper verification	2	Requires pulse length as by design
Check virtual source, neutron slit system and detector positioning in standard and polarised mode	30	Time requirements depend on the beam power – measurements include 1x1mm <sup>2</sup> footprints
Detector calibrations	5	
Commissioning of sample environments	60	Instrument and pool SE equipment
Demonstration experiments, interspersed with frequent standards.		Maybe with friendly users in person.
<b>TOTAL:</b>	130	This is likely optimistic, and assumes most things work first or second time.



# ESS Ramp Up Schedule

Assuming BOT January 2027

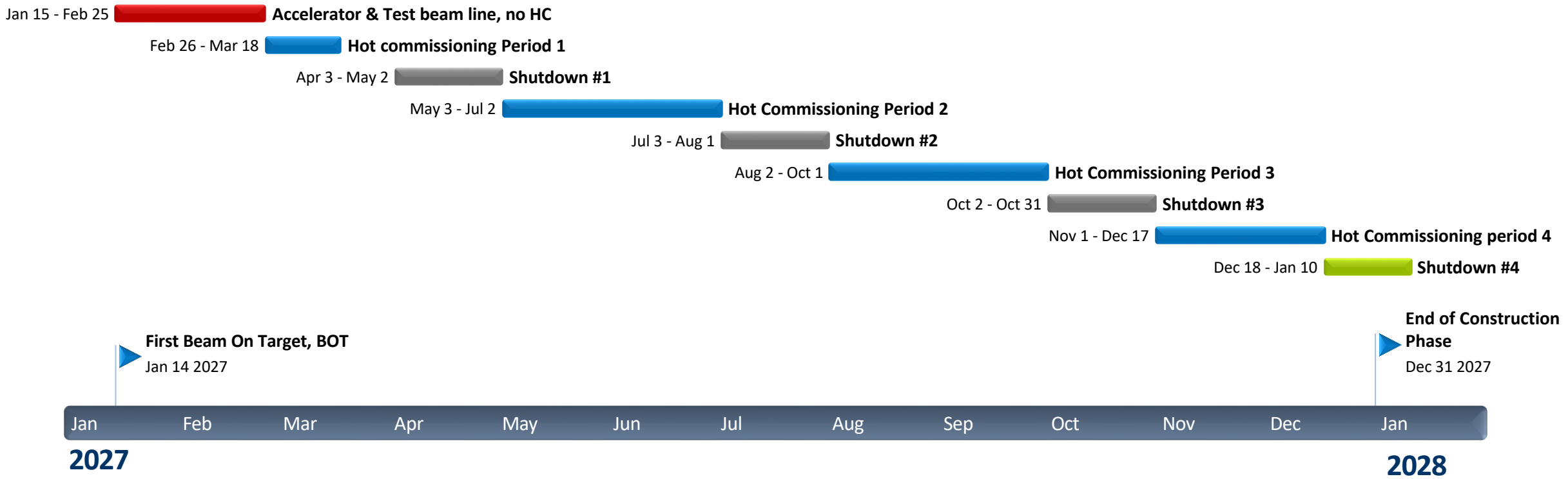



# 2027 \*Draft\*

Exact distribution of shift TBD, but planned ratio 4/3

Deliver 120 days for HC

Complete ESTIA initial HC (BM, SGs, chopper, VS etc)

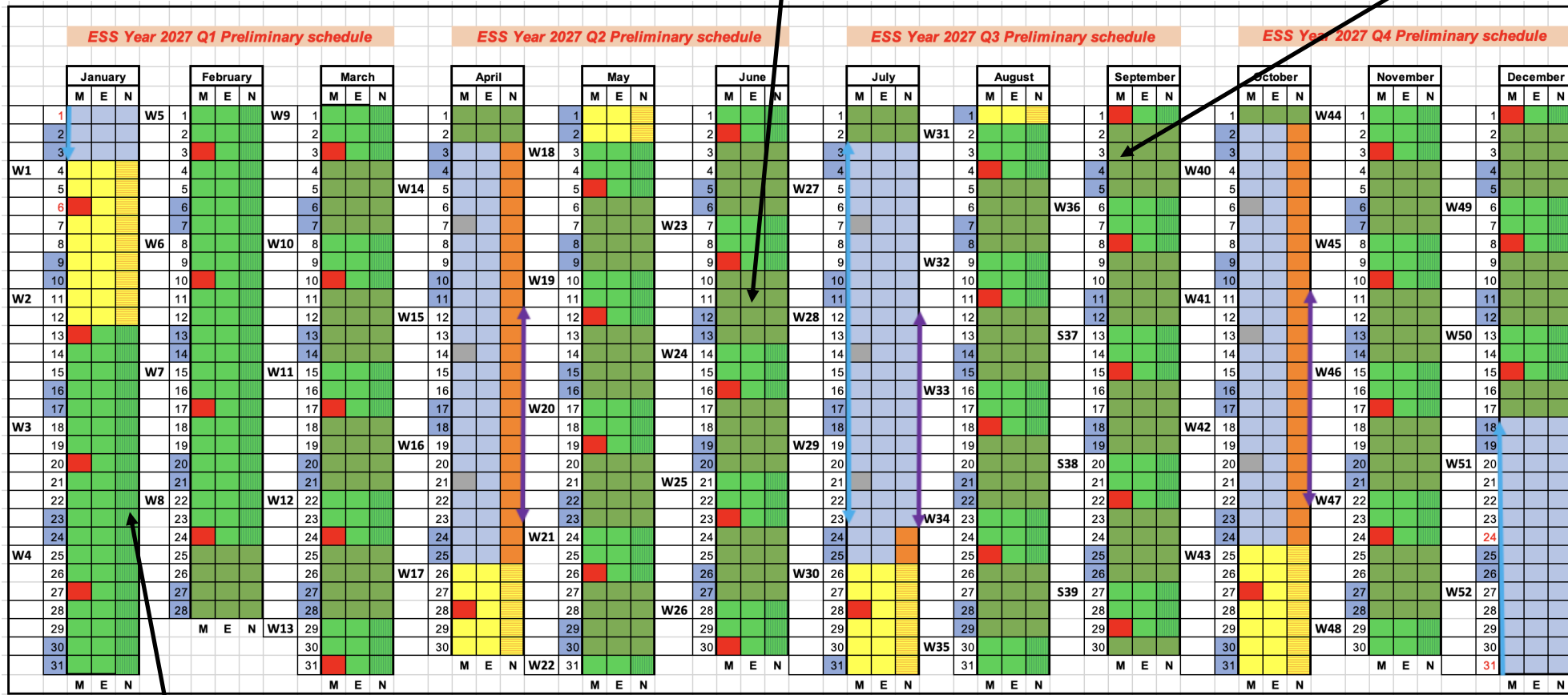

Validate BOT & Establish long pulses on target

Target 120 days for Instruments



# 2028 \*Draft\*

## Exact distribution of shift TBD, but planned ratio 4/3

Complete ESTIA final HC

Deliver 150 days for HC/users

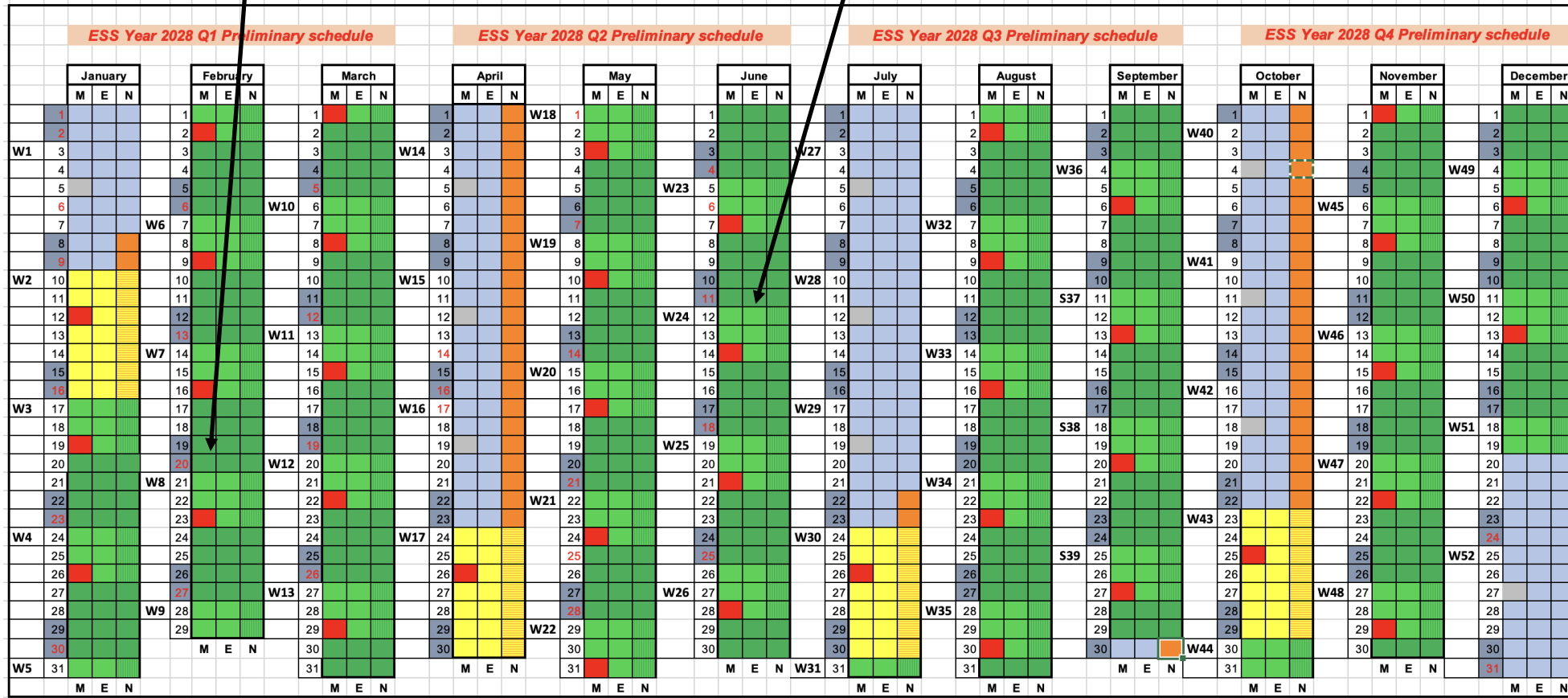

Target 150 days for Instruments

# ESS Ramp Up Schedule

Assuming BOT January 2027



**2027:** 120 days for HC

100 – 200 kW (assumption)

**2028:** 150 days for HC & users

200 kW – 500 kW (assumption)

Beam power during ramp-up is not yet defined

Nominal Beam Power	Estia Neutron Flux (n/s/cm <sup>2</sup> )
< 100 kW	1x10 <sup>4</sup> to 1x10 <sup>6</sup>
> 100 kW (570 MeV)	> 5x10 <sup>6</sup>
> 200 kW (570 MeV)	> 1x10 <sup>7</sup>
> 300 kW (570 MeV)	> 1.6x10 <sup>7</sup>
> 500 kW (800 MeV)	> 4x10 <sup>7</sup>



**EUROPEAN  
SPALLATION  
SOURCE**