

# Cryogenic Systems

## *Part 1: Catching Cold*

J. G. Weisend II

Deputy Head of Accelerator Projects

[www.europeanspallationsource.se](http://www.europeanspallationsource.se)

February 2016

# Goal

- The goal of this tutorial is to provide a background in cryogenics suitable for workers in the field of SRF and Accelerators along with pointers for further study. It will also provide an overview of the ESS Cryogenics system
  - At the end of these talks, you should understand the basics of cryogenics as it applies to accelerators and SRF systems
- The tutorial is divided into 2 logical parts: one on making things cold i.e. refrigeration systems & He II (Catching Cold) and 1 on maintaining things cold i.e. Cryostats and cryomodules (Keeping Cold) plus the ESS cryogenics system.

## Part 1: Catching Cold

- Introduction To Cryogenics
- Basic refrigeration processes
  - Isenthalpic (Joule-Thomson)
  - Isentropic expansion
- Carnot Cycle, COP and FOM
- Collins Cycle and Modern Refrigeration Plants
- He II (Superfluid Helium)
  - Definition and use in SRF systems
  - Two-Fluid Model
  - Heat Transfer
  - Fluid mechanics
  - Second Sound
  - He II Refrigeration Systems

## Part 2: Keeping Cold

- Cryostats and Cryomodules
  - Definitions
  - Materials
  - Thermal Insulation Systems
    - Conduction
    - Convection
    - Radiation
  - Cryostat Examples
- The ESS Cryogenic System

# What is Cryogenics ?

- Cryogenics is the science & engineering of phenomena that occur at temperatures below 120 K
- Cryogenic applications include:
  - Air Separation
  - MRI Systems
  - Cooling of superconducting magnets for research: HEP, Fusion, High Field Labs
  - Liquefaction of gases allows transport at high densities and low pressure: LNG, oxygen, nitrogen, argon, hydrogen, helium
  - Space Applications: LOX, LH<sub>2</sub>, sensor cooling typically below 3 K
  - Biomedical: cryosurgery, cell preservation)
  - Other physics applications: Dark matter searches, calorimeters, EXO
  - Aerospace and military – IR sensing
  - SRF Systems
- While this tutorial will only cover a few of these applications, the basic principles taught apply to all of them

# Some Examples

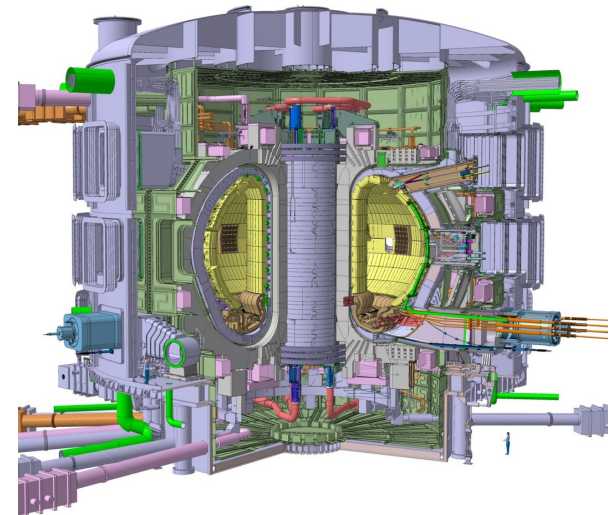
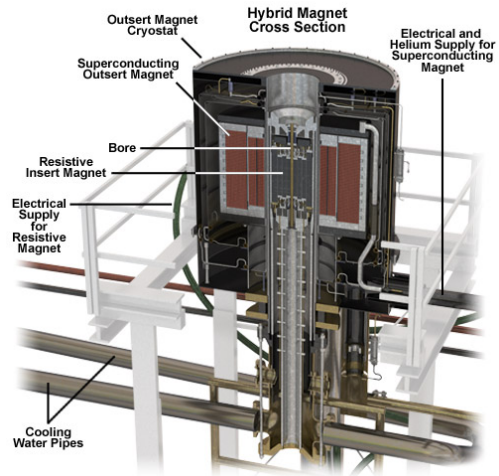

# Why Does ESS use cryogenics?

- Superconducting RF cavities ( see S. Molloy's Talk) provide the bulk of acceleration.
  - Superconductivity means better fraction of electrical power delivered to the beam – you still have to power the cryogenics system though
  - 2 K minimizes wall losses
- Supercritical hydrogen at  $\sim 17$  K provides a high density moderator that results in “Cold Neutrons”
- LHe used in sample environments or to cool s/c magnets in experiments

# Superconducting RF is Very Popular



Name	Accelerator Type	Lab	T (K)	Refrigeration Capacity	Status
CEBAF	Electron Linac	JLab	2.1	4.2 kW @ 2.1 K	Operating
12 GeV Upgrade	Electron Linac	Jlab	2.1	4.2 kW @ 2.1 K	Operating
ESS	Proton Linac	ESS	2.0	3 kW @ 2 K	Under Construction
SNS	H <sup>-</sup> Linac	ORNL	2.1	2.4 kW @ 2.1 K	Operating
E Linac	Electron Linac	TRIUMF	2.0	288 L/Hr	Operating
S-DALINAC	Electron Linac	TU Darmstadt	2.0	120 W @ 2.0 K	Operating
ERL	Electron Linac	Cornell	1.8	7.5 kW @ 1.8 K	Proposed
XFEL	Electron Linac	DESY	2.0 5-8 40-80	2.5 kW @ 2 K 4 kW @ 5-8 K 26 kW @ 40-80 K	Under construction
ATLAS	Heavy Ion Linac	ANL	4.7	1.2 kW @ 4.7	Operating
LCLS II	Accelerator	SLAC	2.1 K	4 kW @ 2 K 14 kW @ 35-55 K 1.2 kW @ 5-8 K	Design (2019) TESLA Tech
ISAC - II	Heavy Ion Linac	TRIUMF	4		Operating
FRIB	Heavy Ion Linac	MSU	2.1 4.5 33/55	3.6 kW @ 2.1 K 4.5 kW @ 4.5 K 20 kW @ 35/55 K	Under Construction



# Catching Cold

- Before we get involved in thermodynamic cycles, let's go over the basics
- There are really only a few ways in which to make a pure fluid such as helium colder
  - Cause the fluid to do work by making it expand against a piston or turbine while keeping it thermally isolated from the outside environment Isentropic Expansion
  - Transfer heat from the fluid to a colder surface
  - Cause the fluid to do “internal work” by expanding it through a valve while keeping it thermally isolated Isenthalpic Expansion
    - Joule-Thomson expansion (more later)
  - Once the fluid is a liquid, reduce the pressure above the fluid below atmospheric pressure thus reducing the saturation temperature
- All modern cryogenic plants do the first 3. Ones that provide cooling below 4.2 K also do the last item

# Generic T-S diagram Showing Isenthalps, Isobars and 2 Phase Region

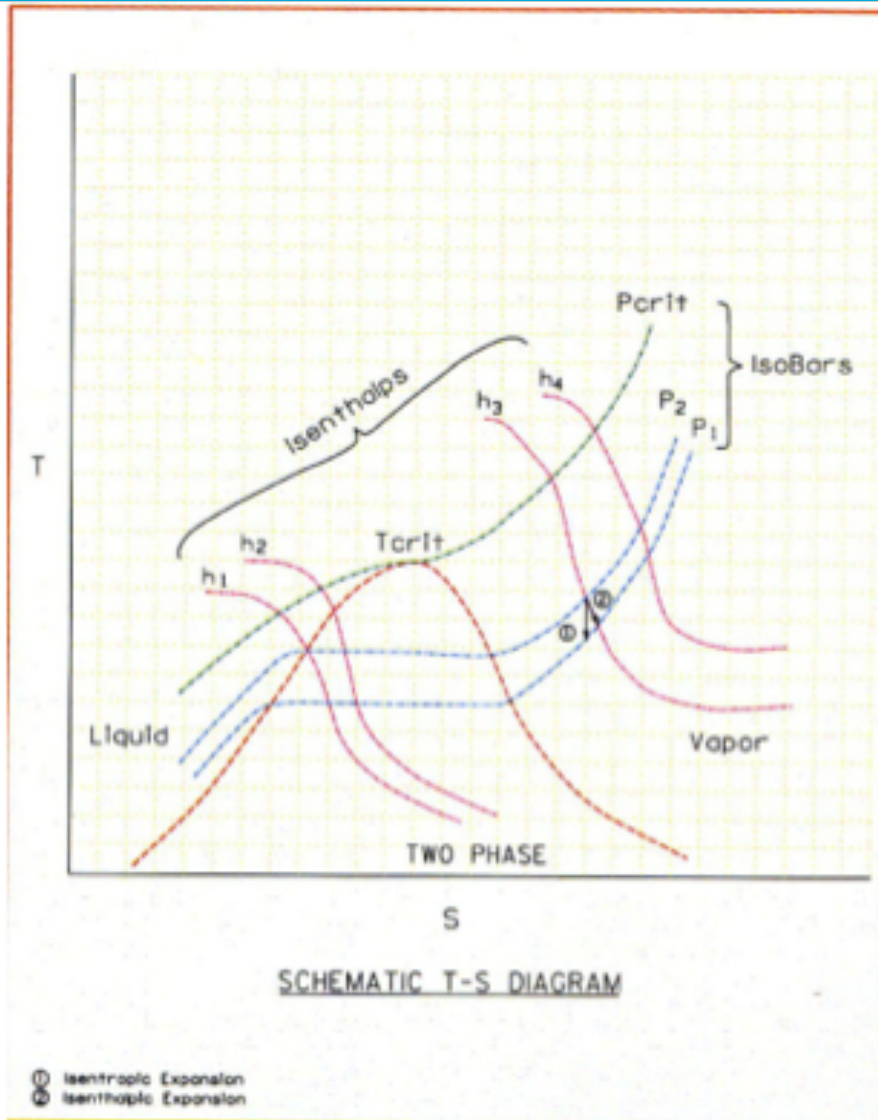

Enthalpy  
 $h = u + pv$

# Carnot Cycle

- This is an ideal cycle: all processes are reversible
  - Entropy is only changed by absorbing or removing heat at constant temperature
  - 2<sup>nd</sup> law of Thermodynamics, in a reversible process  $dQ = -TdS$
- The Carnot Consists of 4 steps
  - Compress the working fluid isothermally at  $T_H$  (1-2)
  - Expand the working fluid isentropically from  $T_H$  to  $T_C$  (2-3)
  - Absorb heat into the working fluid isothermally and reversibly at  $T_C$  (3-4)
  - Compress the working fluid isentropically from  $T_C$  to  $T_H$  (4-1)
  - Note isentropically = reversibly and adiabatically

# Carnot Cycle

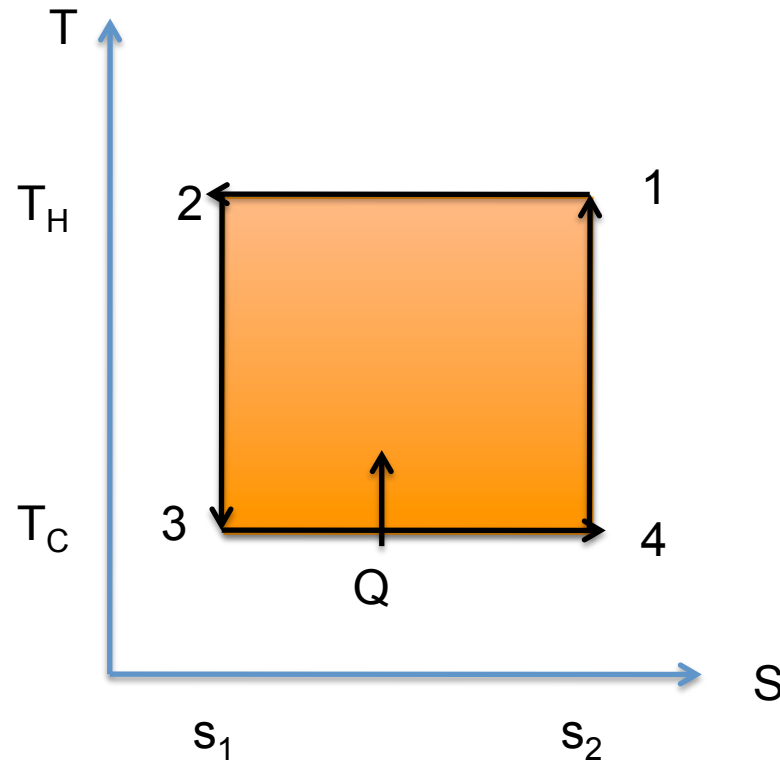

How do we describe the performance of such a cycle?

# Coefficient of Performance & the Carnot Cycle

- Coefficient of Performance: the heat absorbed from the cold sink divided by the net work required to remove this heat

$$\text{COP} = -\frac{Q_a}{W_{net}} = -\frac{\left(\frac{Q_a}{m}\right)}{\left(\frac{W_{net}}{m}\right)}$$

- Minus sign takes into account that the heat absorbed by the cycle is positive while the work done is negative
- For the ideal (and in practice unachievable) Carnot cycle it can be shown that:

$$\text{COP} = -\frac{Q_a}{W_{net}} = \frac{T_C}{T_H - T_C}$$

# Coefficient of Performance & the Carnot Cycle

- For a plant operating between room 300 K and 4.2 K, the Carnot COP is  $4.2/(300 - 4.2)$  or 0.0142
- The Carnot cycle is the ideal case. It is the best you can do without violating the laws of thermodynamics
- Note that the form of the Carnot COP shows that you have a better COP (thus a more efficient process or refrigerator) if  $T_C$  is large
  - It is always thermodynamically more efficient to intercept heat (provide cooling) at higher temperatures
  - This fact drives a lot of cryogenic design
- In practice, we generally discuss the inverse of the COP because this allows us to describe the number of watts of work required to provide 1 Watt of cooling at a given temperature. For a Carnot cycle providing cooling at 4.2 K. This is **70 W/W**
  - People will frequently and incorrectly refer to this as a COP as well

# Carnot Cycles & the Real World

- Can we build a real machine using a Carnot cycle? In a word NO
- Why?
  - Compressing a fluid isothermally is very hard to achieve, Normally the fluid is compressed and then cooled back down to 300 K
  - Expanding or compressing fluid isentropically is basically impossible
  - We can absorb heat into a boiling fluid isothermally but not with out irreversible losses

- How close can we get to Carnot? We define the Figure of Merit (FOM) as:

$$FOM = \frac{COP}{COP_{Carnot}}$$

- We also speak in terms of “percent Carnot” i.e. FOM of 0.2 is 20% Carnot

# The real world is sometimes not kind to cryogenic engineers

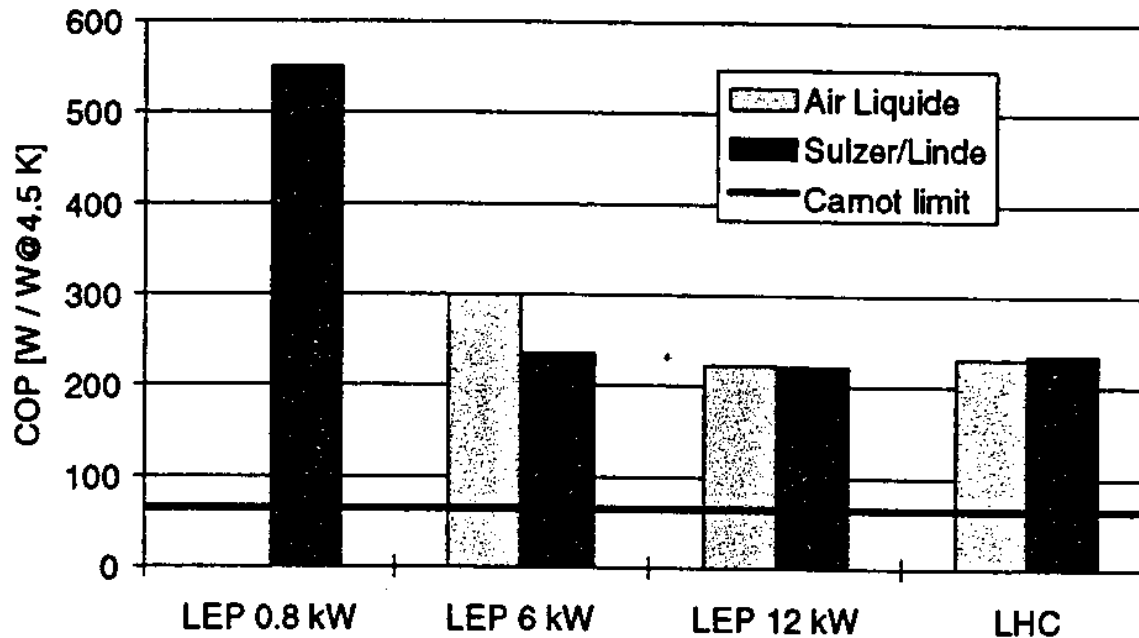

- These are state of the art helium refrigerators. Note that the best of them (for LHC) runs at about 220 W/W or a FOM of 0.318 or at 32% Carnot



# Practical Impact of Plant Performance

- How much power does it take to operate a large cryogenic refrigeration plant?
- AT ESS we expect to have a refrigeration plant capable of removing as much as 9.5 kW at 4.5 K. The FOM of the plant is expected to be 0.26

If the plant operates as expected this means we will need:

$$(66/0.26) \times 9500 = 2.4 \text{ MW of mechanical power}$$

- We are adding some additional margin to the electrical power requirements and have asked for at least 2.6 MW available for powering the compressors

# Joule-Thomson Expansion

- Isenthalpic ( $h=\text{constant}$ ) expansion
- Fluid cools as is it is expanded at constant enthalpy through a valve
- However, depending on both the fluid and the temperature, such an expansion can also cause heating.
- Define the Joule-Thomson expansion coefficient  $\mu_j \equiv \left( \frac{\partial T}{\partial P} \right)_h$
- $\mu_j$  must be positive for cooling to occur
- Cooling by JT expansion has some advantages
  - No moving parts
  - Can easily handle two-phase mixtures

# JT Inversion Curve & Maximum Inversion Temperatures

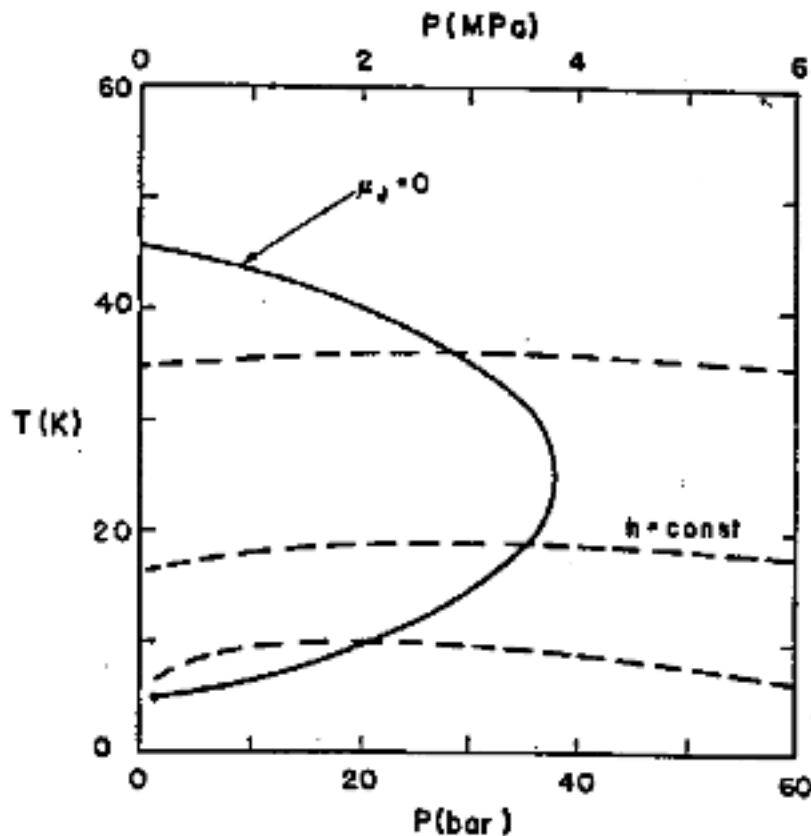

Inversion curve for Helium

Fluid	Max Inversion Temperature (K)
Nitrogen	623
Argon	723
Hydrogen	202
He	43

- Maximum inversion temperature for helium is 43 K
- Note that below  $\sim 2$  K He again warms on JT expansion
- Many fluids, such as  $N_2$  can be liquefied using JT expansion – JT cycle

- Modern large scale Helium refrigerators/liquefiers use a variation of the Claude cycle known as the Collins cycle
- The key difference between these cycles and the JT cycle is the addition of expansion engines (pistons or turbines) that the fluid does work against and thus cools
- The process through these expansion engines may be idealized as Isentropic ( $s = \text{constant}$ ) expansion
  - Cooling occurs at any temperature
  - $\Delta T$  for a given  $\Delta P$  is much larger than for isenthalpic expansion
- Claude cycle = 1 expansion engine, Collins cycle = multiple expansion engines
  - The post WW II development of the Collins liquefier revolutionized laboratory research in cryogenics

# Claude Cycle

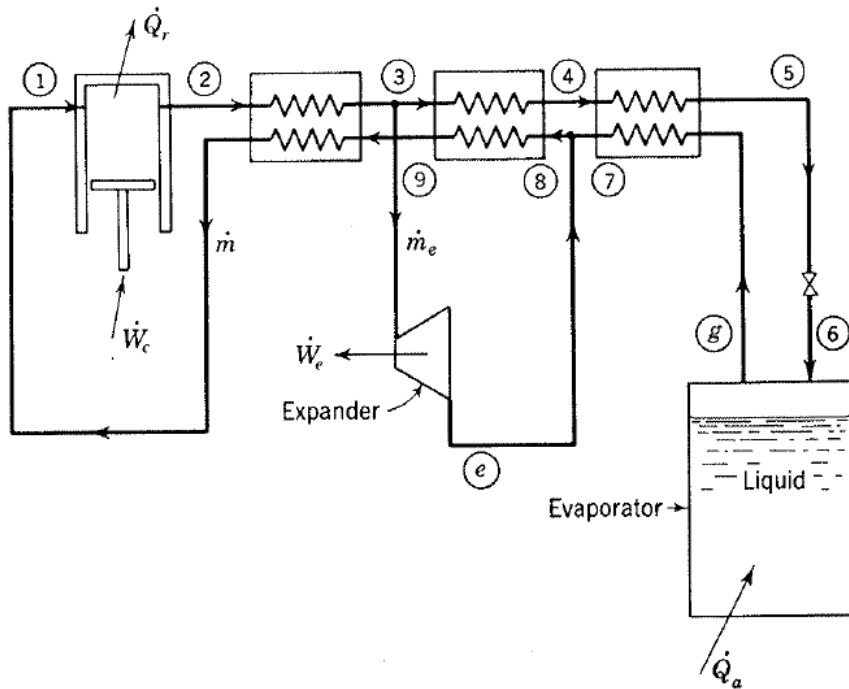

From Cryogenic Systems  
R. Barron

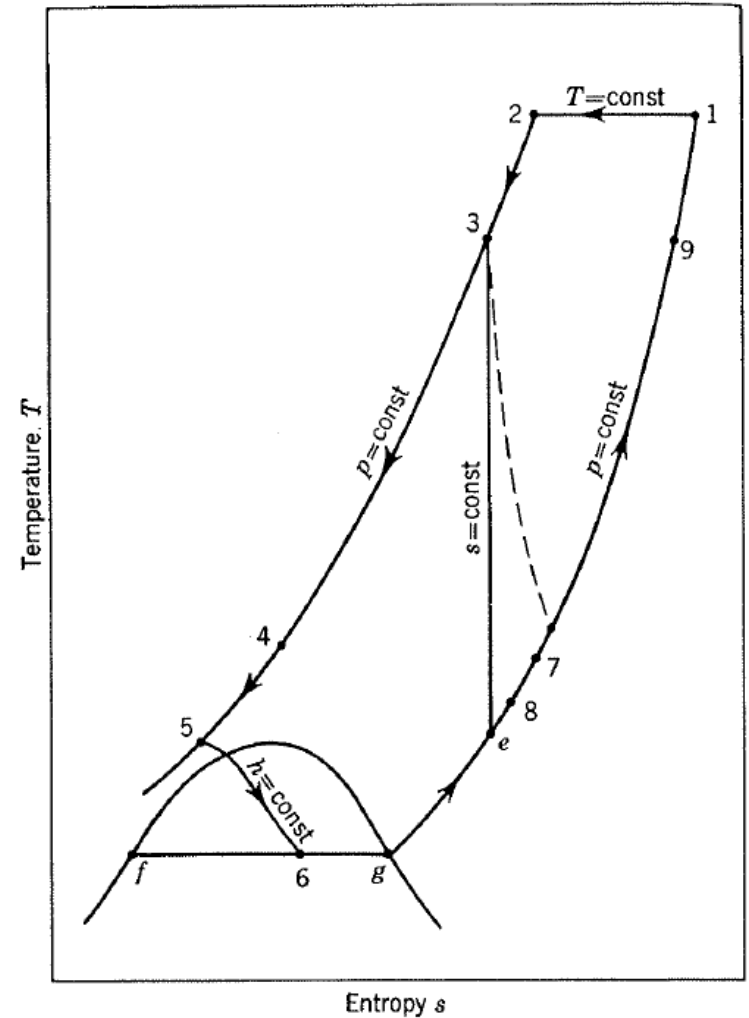

- **Cycle consists of :**
  - 1) Compression to ~ 16 Bar with cooling back to 300 K + oil removal**
  - 2) Cooling of high pressure gas with LN<sub>2</sub>**
  - 3) Isentropic expansion via 2 or more expansion engines**
  - 4) Cooling of high pressure gas by the cold returning low pressure stream**
  - 5) Isenthalpic expansion through JT valve**
  - 6) Return of gas to compressors at just above 1 Bar**

# CTI 4000 Refrigerator (early 80's vintage ~ 1.2 kW @ 4.5 K)

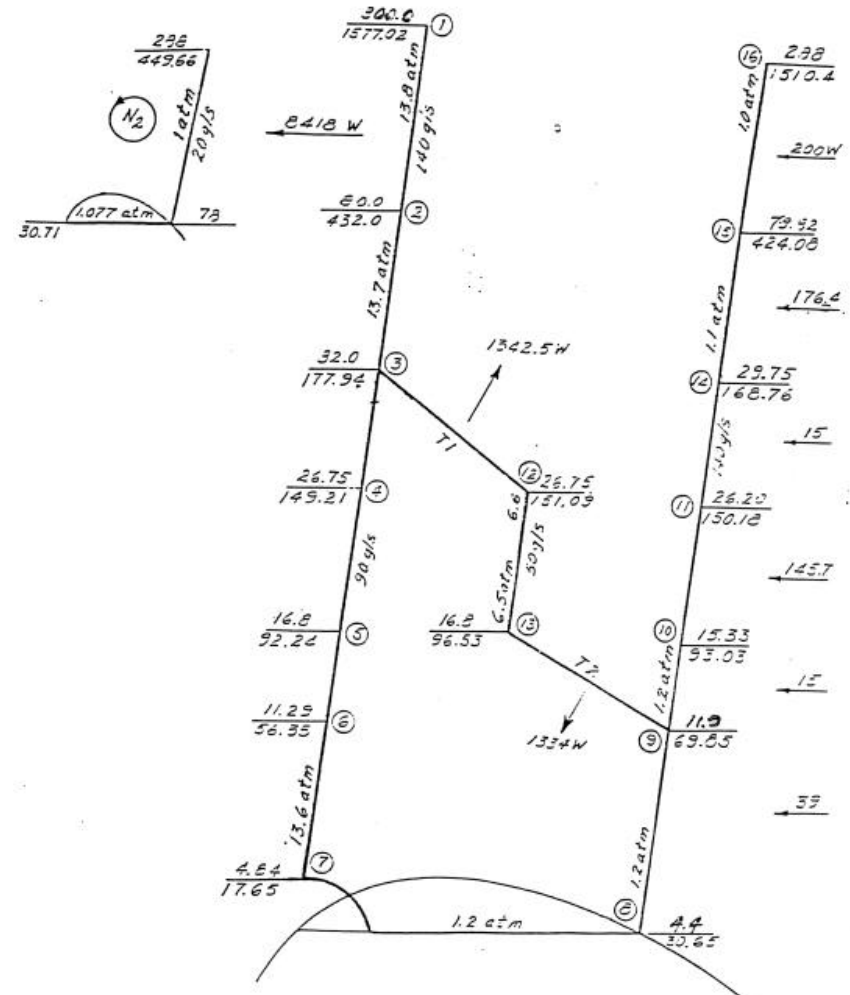
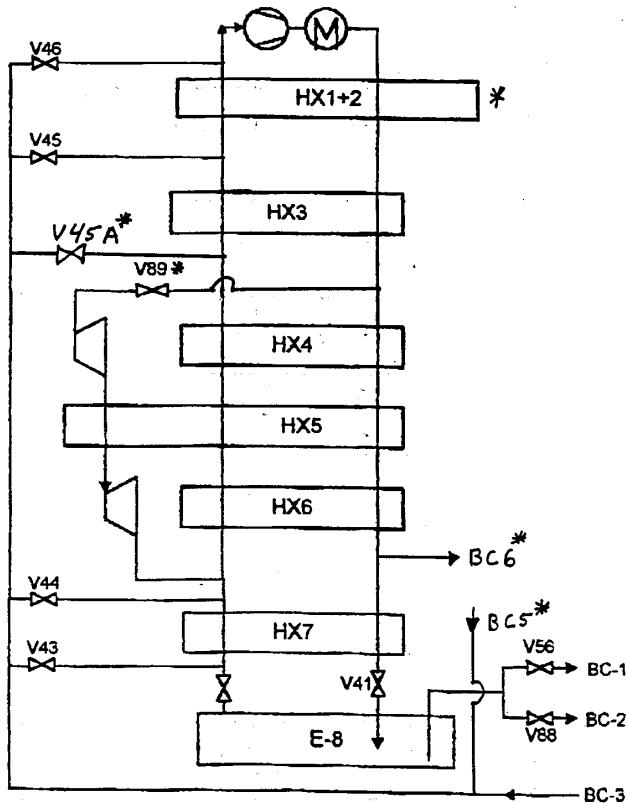

CTI 4000 Upgrade 12 / 2 / 99

\* Indicates new or changed component

# LHC 4.5 K Refrigeration Plant

18 kW @ 4.5 K – produced in ~ 2004  
1 of 8 required (4 from Linde, 4 from Air Liquide)

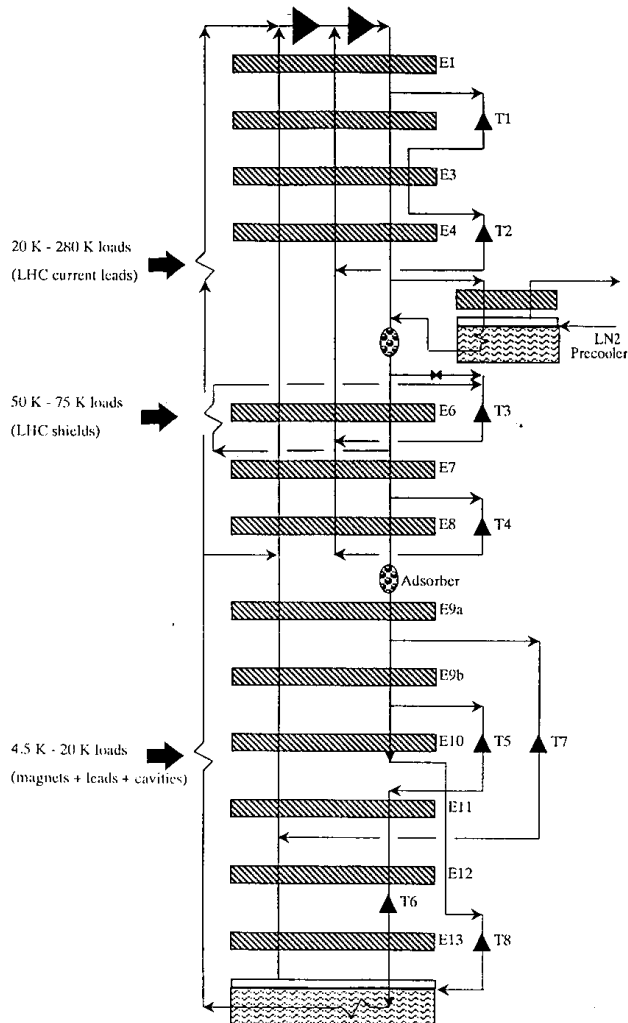

## Note:

- Large number of expansion turbines – some in series with HP stream
- Medium pressure return
- Heat loads at intermediate temperatures
- Designed to have high % Carnot (roughly 30%)



# Accelerator Cryoplant for ESS (Linde)

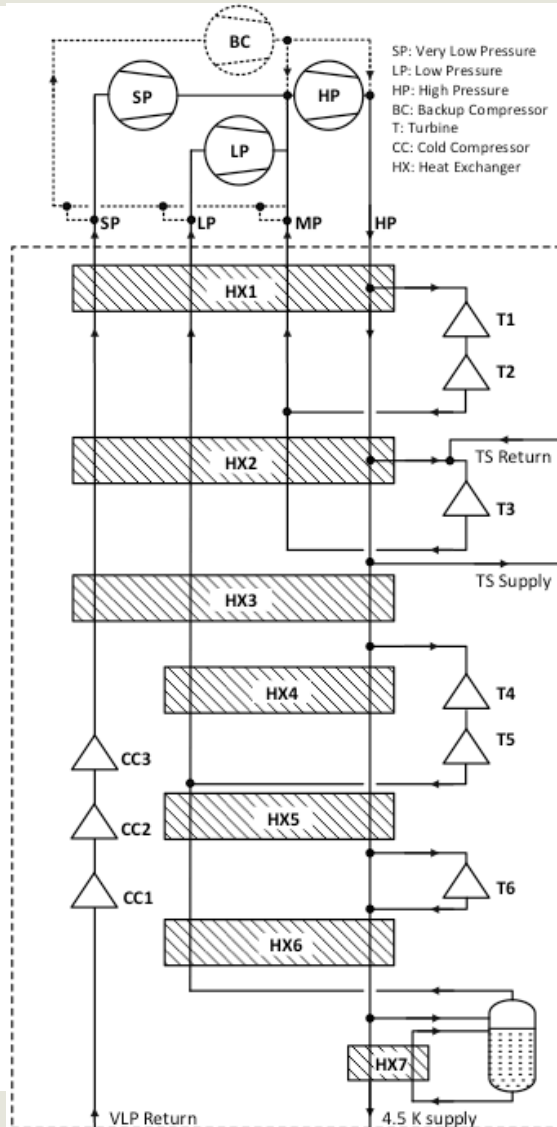

Note:

- 1) No LN<sub>2</sub> Precooling
- 2) Last stage of subatmospheric pumping is warm
- 3) Provides up to 3 kW @ 2K

# Refrigerators vs. Liquefiers

- Refrigerators are closed cycle systems
  - They provide cooling and can create liquids but all the mass flow is returned to the start of the cycle
  - Such systems are said to have “balanced flow”
- Liquefiers are open cycle systems
  - They provide a liquid which is then drawn off and used elsewhere
  - These have “unbalanced flows” the amount of mass returned to the start of the cycle is less than the amount that started by the mass that was converted to liquid.
  - In order to keep the cycle running this mass would have to be added as room temperature gas.

# Refrigerators vs. Liquefiers

- In practice, this distinction is less clear cut
  - Modern cryogenic plants can operate either as refrigerators or liquefiers and in fact, generally operate as a mixture of the two.
  - We talk about refrigeration loads & liquefaction loads
  - A key issue is at what temperature is the boil off gas from a cryogenic liquid returned to the cycle?
    - If brought back at a cryogenic temperature and used to cool incoming warmer gas then this is a refrigeration load
    - If brought back warm and not used to cool incoming warmer gas this is a liquefaction load
- The thermodynamic rules are the same for refrigerators and liquefiers

# Consider the cooling of a superconducting magnet and its current leads

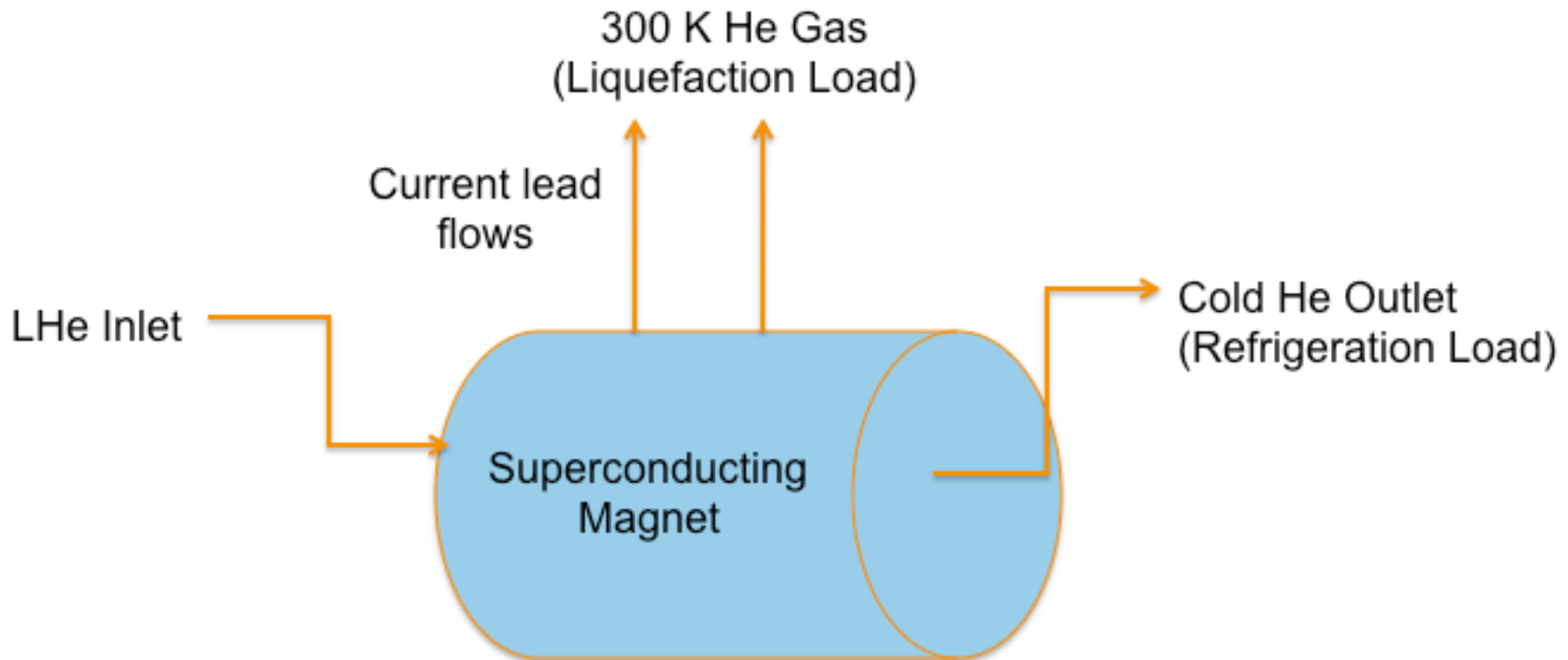

# He II (Superfluid Helium)

- 2<sup>nd</sup> liquid phase of helium (hence He II)
- Phase transition is 2<sup>nd</sup> order (no latent heat) but there is a discontinuity in the specific heat ( $\lambda$  transition)
- $T_{\lambda\max} = 2.2 \text{ K}$
- Has unique thermal and fluid properties
  - High effective thermal conductivity
  - Zero viscosity under certain conditions

# Helium Phase Diagram

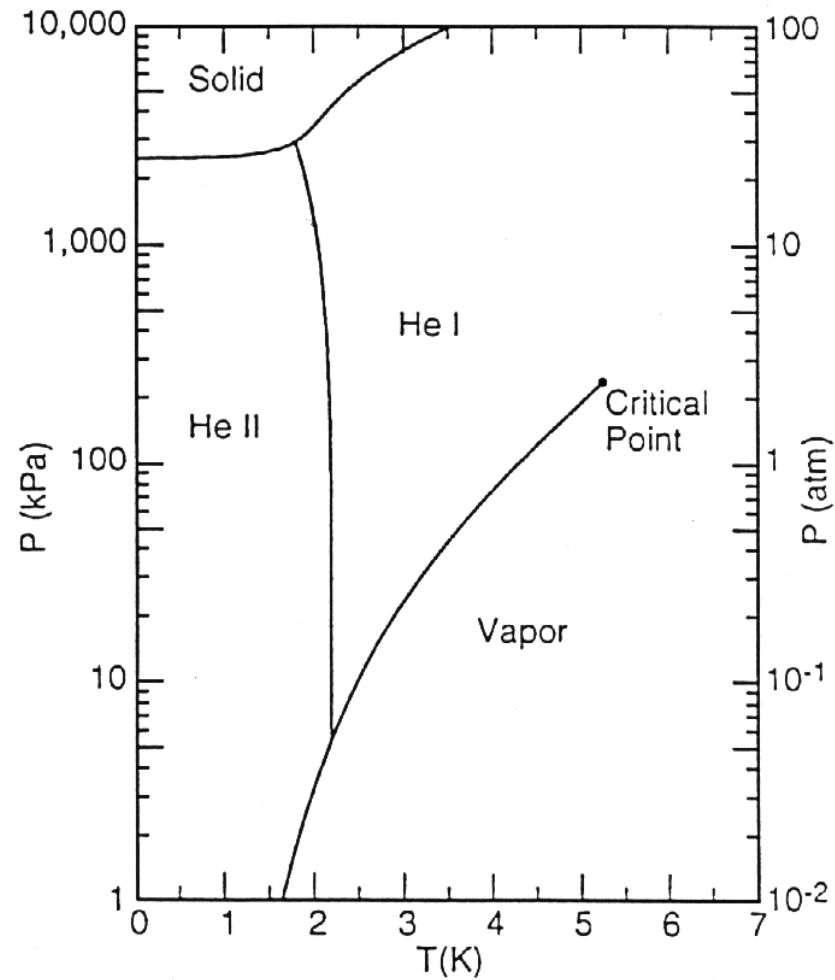

# Why Use He II in SRF Systems?

- The biggest single advantage is the lower temperature (<4.2 K)
  - Lower temperature means lower BCS losses in cavities, size of effect is RF frequency dependent
  - He II refrigeration is more costly (due to Carnot & machine inefficiencies)
  - Generally speaking, removing 1 W at 2 K is the equivalent of removing 3 W at 4.2 K
  - There is a point at which the gain from lower BCS losses is better than the additional cost of refrigeration
- An additional advantage is the very efficient heat transfer mechanism in He II
  - This results in no bulk boiling which reduces microphonics
- The majority of new SRF systems operate in the He II regime

# What is He II ?

- A “Bose – Einstein like” Condensate
  - A fraction of atoms in He II have condensed to the quantum ground state
  - He II was the first of these condensates discovered
  - The only one that has significant industrial applications
- The properties of He II can be understood via the two fluid model



# Two Fluid Model

- He II can be thought of a fluid with two interpenetrating components:
  - Normal fluid component
    - Finite viscosity
    - Finite entropy
  - Superfluid component
    - Zero viscosity
    - Zero entropy
- The interaction of these components can explain He II behavior

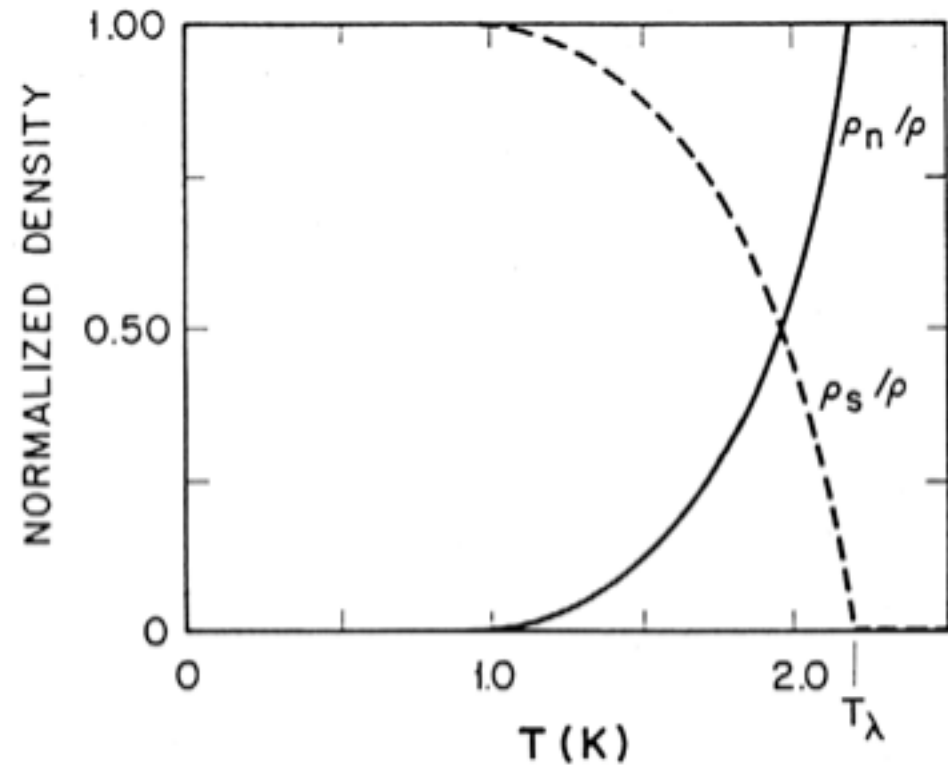

Relative Densities of Superfluid and Normal fluid components  
(From Helium Cryogenics – Van Sciver)

# Quantized Vortices

## (or does He II at 1 K rotate in a bucket)

- At 1 K He II is almost entirely the superfluid component and thus has almost 0 viscosity. This would imply that He at 1 K in a spinning bucket wouldn't rotate but it does. What's the answer?
  - The vortices are quantized:
$$C = \int V_s \cdot dl = n \frac{h}{m}$$
- Solves rotating bucket problem
  - In the body of the fluid:  $\nabla^2 V_s = 0$
  - At the wall:  $\nabla^2 V_s \neq 0$
- This has been experimentally observed
- The quantized vortices in the superfluid component are an important part of heat transfer mechanism in He II

# Direct Observation of Quantized Vortices via Electron Trapping

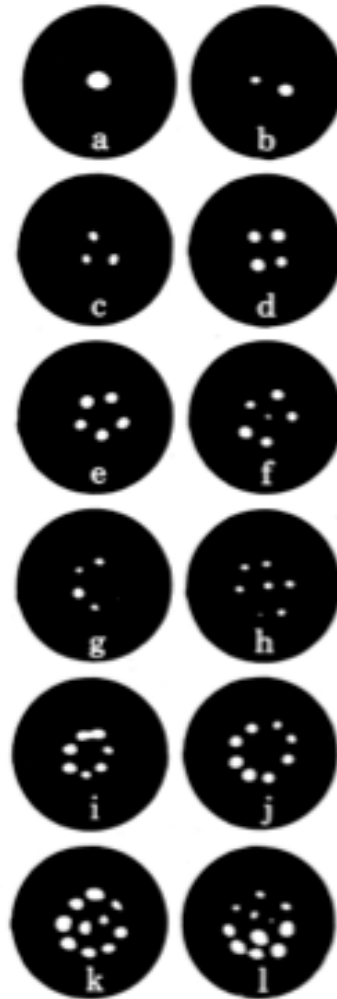
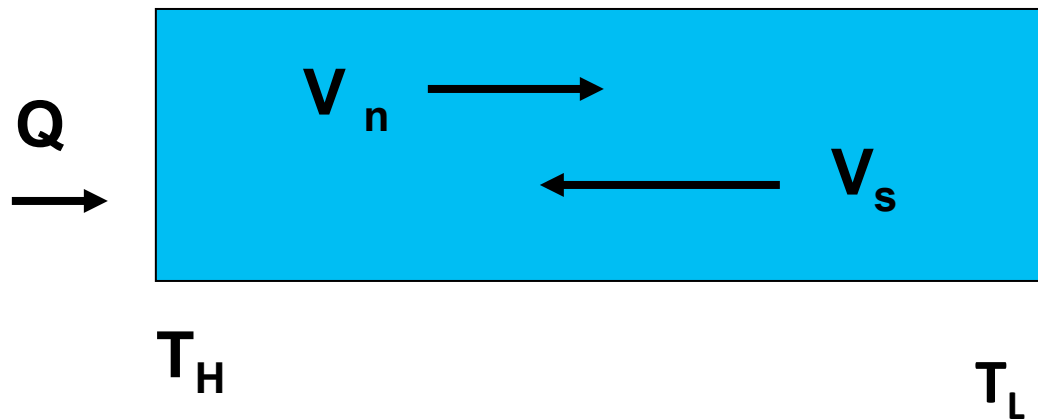

Fig. 4.26. Photographic reproduction of vortex line array in rotating HeII (from Yarnchak and Packard<sup>12</sup>): (a) through (l) indicate increasing angular frequency.

# Heat Transfer in He II

- The basic mechanism is internal convection:



- No net mass flow
- Note that this is not conduction or classical convection but an entirely different heat transfer mechanism
- This can be extremely efficient (more than 1000x better than conduction through copper)

# Heat Transfer in He II

- There are 2 heat transfer regimes:

- $V_s < V_{sc}$

$$q = \frac{(\rho s d^2) T}{\beta \eta_n} \frac{dT}{dx}$$

- $V_s > V_{sc}$

- Mutual Friction Regime (quantized vortices interact with the viscosity of the normal component)

$$q = \left[ f^{-1}(P, T) \frac{dT}{dx} \right]^{1/3}$$

- As  $V_{sc} \sim d^{-1/4}$  (cgs units) the mutual friction regime is most applicable in engineering applications of He II

# Heat Conductivity Function

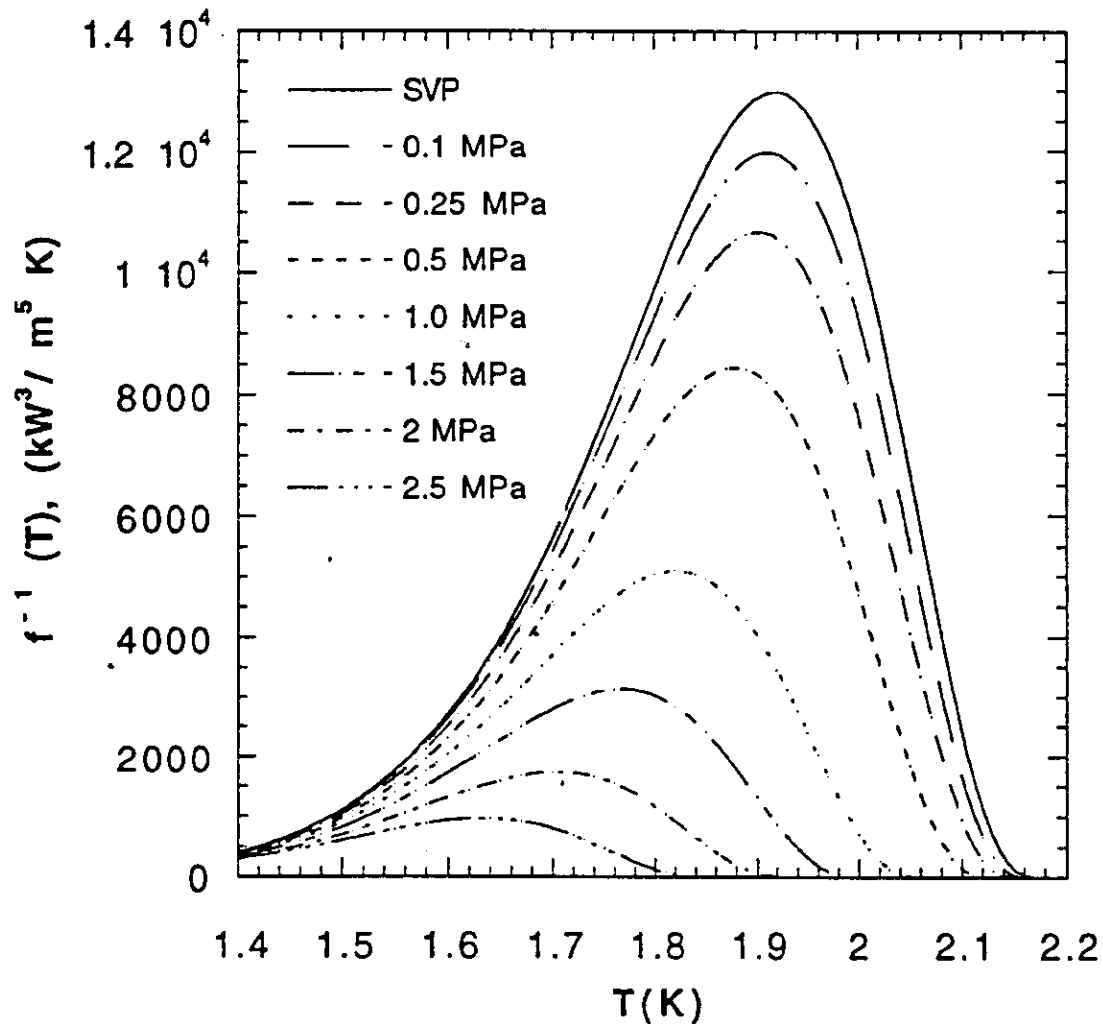

# He II Heat Transfer Limits

- In pressurized He II:  $T_h$  must be less than  $T_\lambda$
- Thus the peak heat flux  $q^*$  is:

$$q^* L^{1/3} = \left( \int_{T_b}^{T_\lambda} f^{-1}(T) dt \right)^{1/3}$$

- At 1.9 K and 1 bar :

$$q^* L^{1/3} \sim 15 \text{ kW/m}^{5/3}$$

# Peak Heat Flux ( $q^*$ ) in Pressurized He II

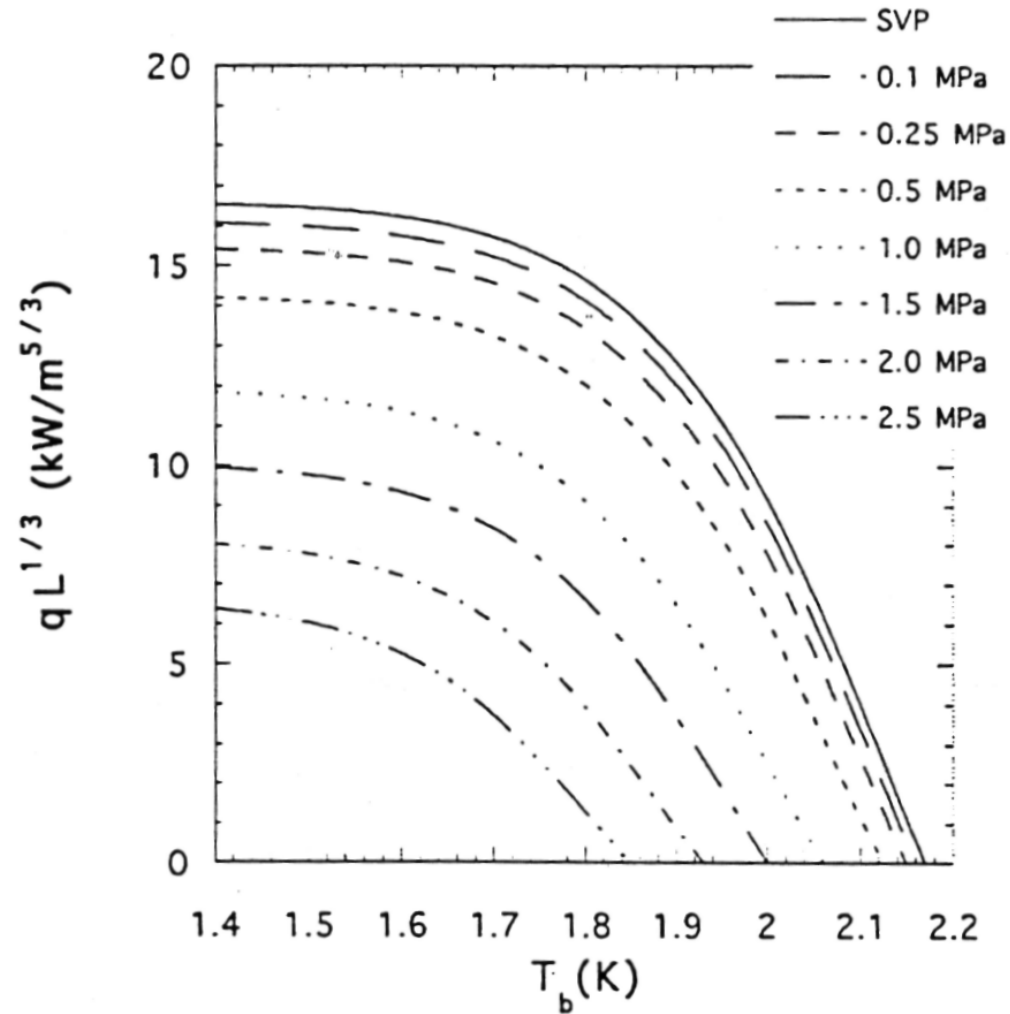



# Limits on He II Heat Transfer

- In saturated He II, the limit is given by the local saturation temperature & the degree of local subcooling
- In the ILC cavity He vessel this works out to about  $1 \text{ W/cm}^2$  or  $\sim 30 \text{ W}$  total through the connection tube
  - More heat than that would require a redesign
- Exceeding the heat transfer limits in either the saturated or pressurized case results in conversion to He I and boiling at the heated surface

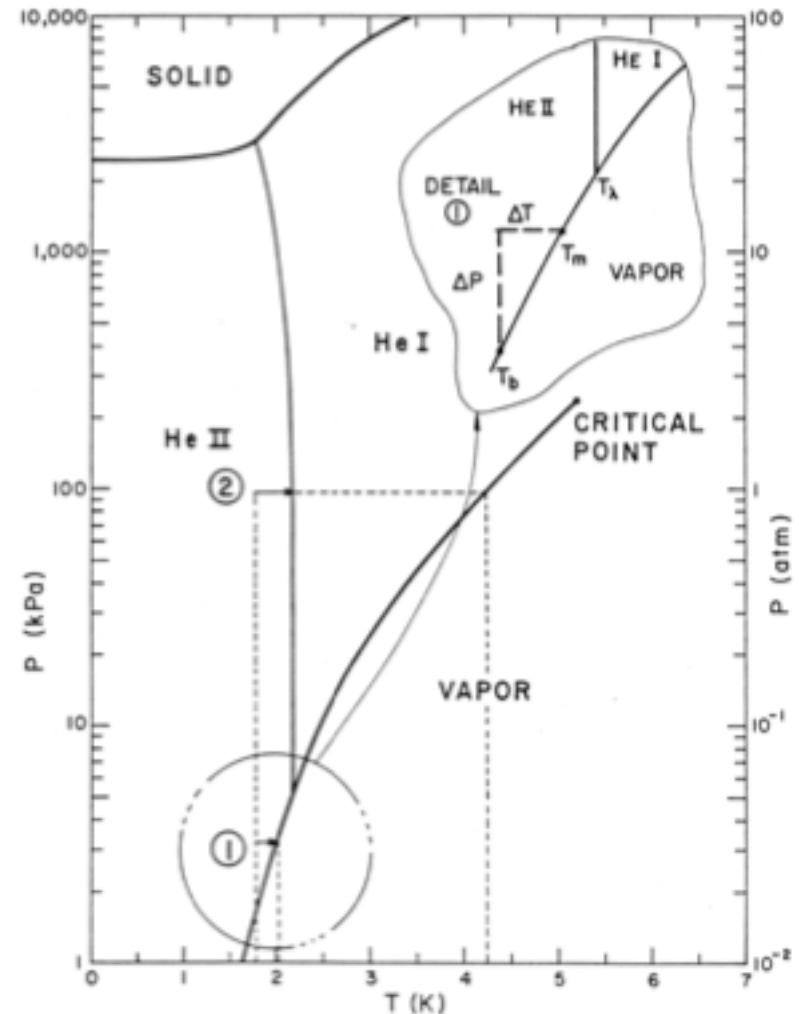

# Surface Heat Transfer

- Heat transfer from a surface into He II is completely dominated by a fundamental inefficiency in moving energy from the surface to the fluid
- This effect exists but is not important in standard convection problems
  - Normally we assume  $T_w = T_{fw}$  but this is not true in the case of He II
- This surface heat transfer effect is described by Kapitza Conductance
  - For  $q < 1 \text{ kW/m}^2$  
$$q = h_K \Delta T_S$$
  - For  $q > 1 \text{ kW/m}^2$  
$$q = a(T_s^m - T_b^m)$$
- $h_k$ ,  $a$  and  $m$  are empirical and dependent on material, temperature and surface condition

# Surface Heat Transfer

- $m \sim 3$
- Kapitza conductance is not dependent on helium flow rate

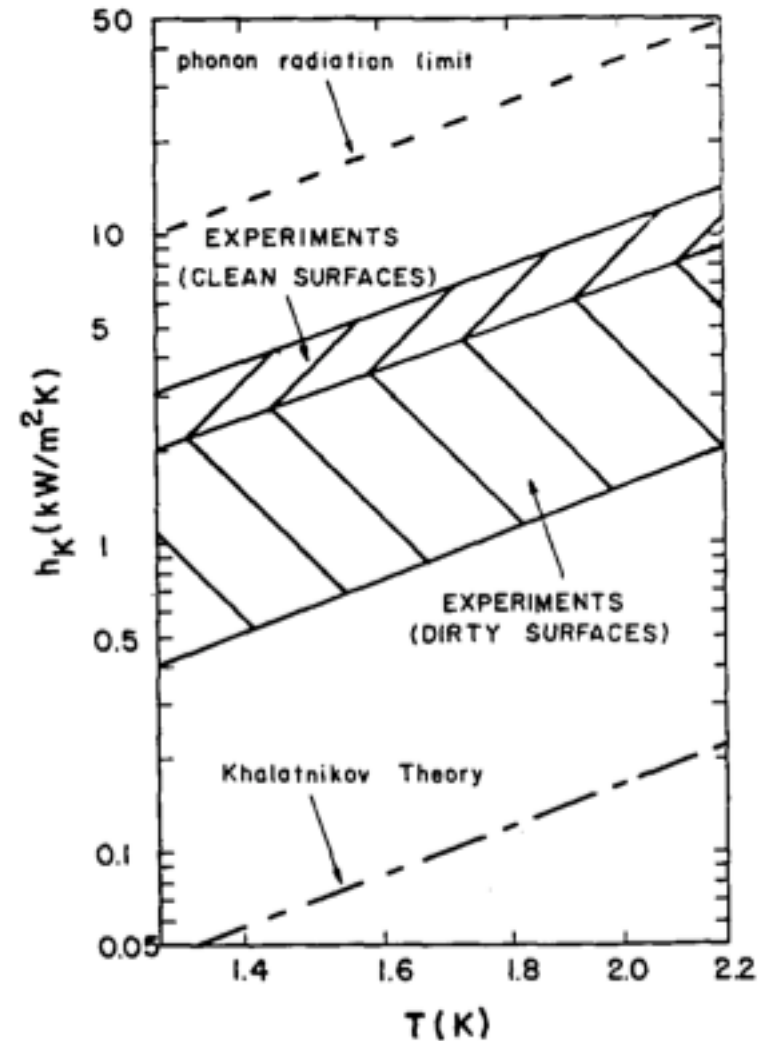

# Forced Convection and He II

If Kapitza Conductance is independent of flow rate does forced convection in He II make any sense?

Yes! Forced convection has the effect of reducing the maximum temperature in the He II and thus allowing more heat to be transferred before reaching the peak heat flux

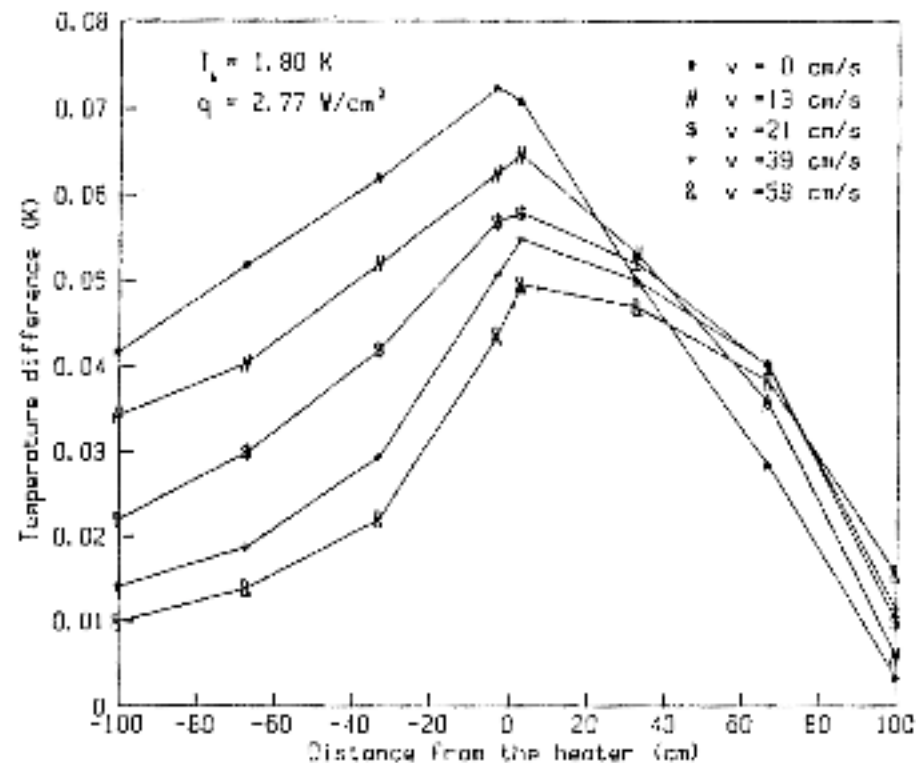

# He II Fluid Dynamics

- Despite the presence of the superfluid component, in almost all engineering applications He II behaves as a classical fluid. This includes :
  - Pump performance
    - » Except cavitation in saturated He II
  - Pressure drop in tubes, valves, bellows and fittings
  - Flow metering techniques
- This is likely a result of the quantized vortices in the superfluid component being coupled via mutual friction to the normal fluid viscosity
- However, keep in mind that the unique heat transfer properties still exist as described.

# He II Fluid Dynamics

- He II does behave differently in cases of:
  - Film flow
  - Porous plugs
  - Two – phase flow (liquid/vapor) due to the large density difference between liquid and vapor in the case of He II

# Second Sound

- The two-fluid model predicts and experiments show that temperature waves may be established in the He II due to oscillations in the local entropy. These temperature waves are known as second sound as they are analogous to density waves caused by pressure oscillations.
- Recall that the superfluid component has zero entropy

**Table 6.2** Comparison of sound propagation in He II From [Helium Cryogenics](#), S.W. Van Sciver (2013)

	First sound	Second sound
Driving force	$\delta p$	$\delta T$
Propagator	$\delta \rho$	$\delta s$
Density ( $\rho$ )	Wavelike	$\sim$ constant ( $\rho_n \mathbf{v}_n \approx -\rho_s \mathbf{v}_s$ )
Temperature ( $T$ )	$\sim$ constant ( $\mathbf{v}_s \approx \mathbf{v}_n$ )	Wavelike
Speed	$c_1 = \left(\frac{\gamma}{\rho \kappa}\right)^{1/2} \approx 240 \text{ m/s}$	$c_2 = \left(\frac{\rho_s}{\rho_n} \frac{T s^2}{C_v}\right)^{1/2} \approx 20 \text{ m/s}$
Relationship	$\nabla^2 p = \frac{\partial^2 \rho}{\partial t^2}$	$\nabla^2 T = \frac{\rho_n}{s^2 \rho_s} \frac{\partial^2 s}{\partial t^2}$

# Second Sound

- Second sound can be detected via
  - thermometry (either time or flight or resonance techniques)
  - Oscillating Superleak Transducers
- Second sound is attenuated by mutual friction and has been used extensively quantum turbulence
- More recently second sound has been used to locate quenches in SRF cavities

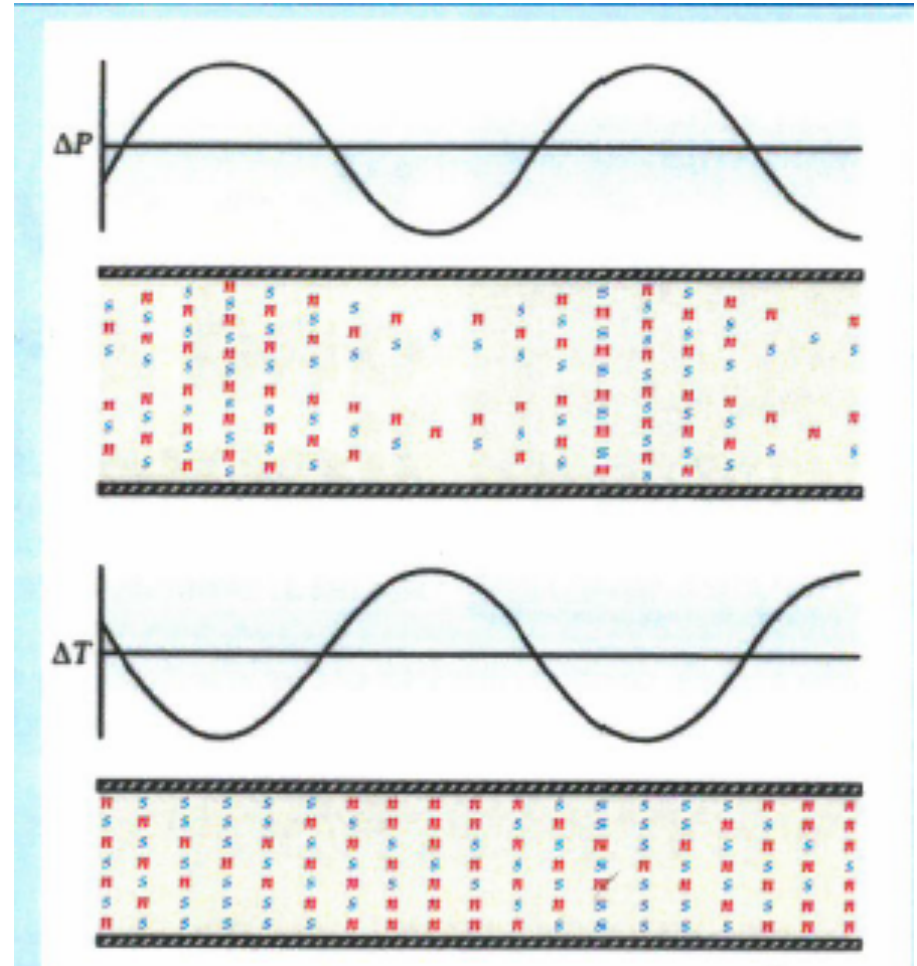



# Typical He II Refrigeration System

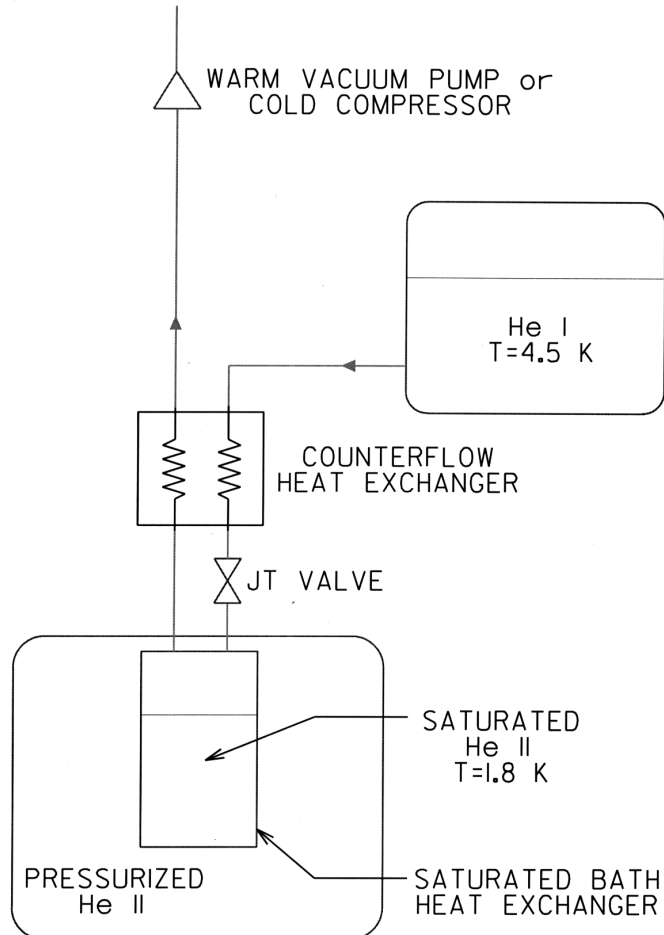

*He II (Superfluid Helium) S. W. Van Sciver, in Handbook of Cryogenic Engineering,*

There 2 approaches to providing He II To SRF systems:

- 1) Create the He II for a given string of components and distribute it (LHC, XFEL, CEBAF)
  - Less expensive, fewer warm/cold transitions
- 2) Create the He II at each cryomodule (12 GeV, SNS, ESS, FRIB)
  - Less Heat load to 2 K
  - Better flexibility

# He II Summary

- He II is a unique fluid that displays quantum behavior on a macroscopic scale
- He II has significant applications in large scale cryogenics for scientific research
- Despite its unique properties, the use of He II in industrial scale engineering applications is well understood and significant experience exists: Tore Supra, LHC, Jlab, NASA