

ICS Handbook

Henrik Carling

www.europeanspallationsource.se

2017 March 2016

What is ICS about?

- The ESS facility is a large and complex machine with very, very much equipment that needs to work in synchronization - and with well-known configurations
- For this purpose almost all equipment at the ESS facility is connected to the **Integrated Control System**
- The control system is the "central nervous system of ESS"
- Examples:
 - Voltage supplies for magnets
 - Vacuum systems
 - Cryogenic equipment
 - RF equipment
 - Air conditioning in the tunnel
- An estimated **1.5 million** control points will be needed

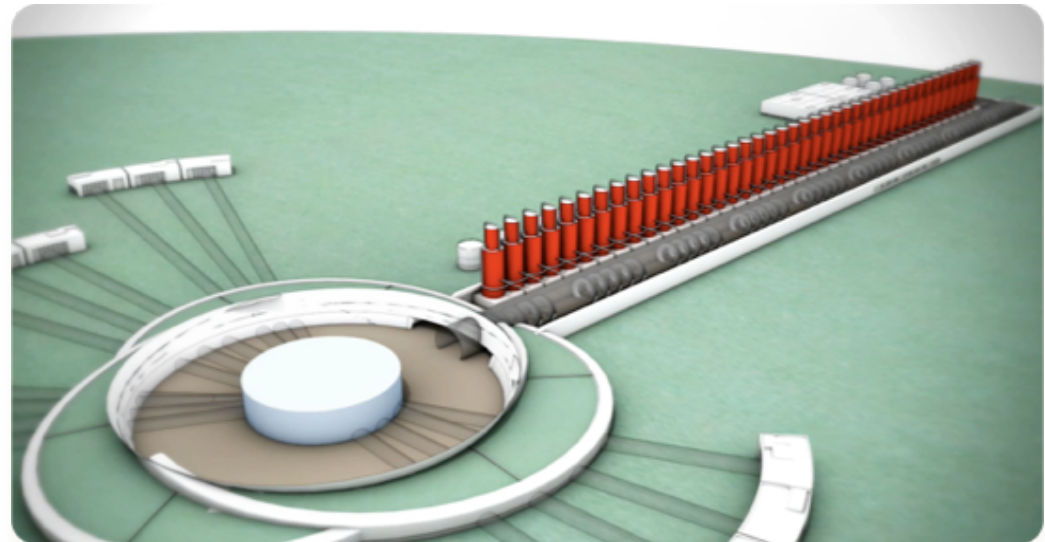

ICS Work breakdown structure

- Work package 01 Management and administration
- Work package 02 Software Applications
- Work package 03 Software core
- Work package 04 Hardware core
- Work package 05 Machine protection system
- Work package 06 Equipment
- Work package 07 Control system infrastructure
- Work package 08 Physics
- Work package 09 Personnel safety system
- Work package 10 Integration - Accelerator
- Work package 11 Integration - Target
- Work package 12 Integration - Instruments
- Work package 13 Integration - Conventional facilities
- Work package 14 Test Stands
- Work package 20 Installation



Software

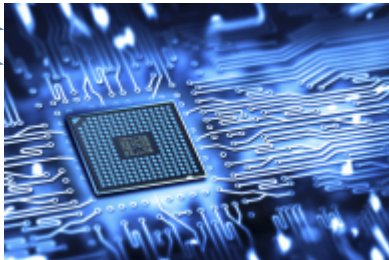

Electronics



Infrastructure



Safety & protection

ESS ERIC

BOARD OF DIRECTORS
DIRECTOR GENERAL



EUROPEAN
SPALLATION
SOURCE

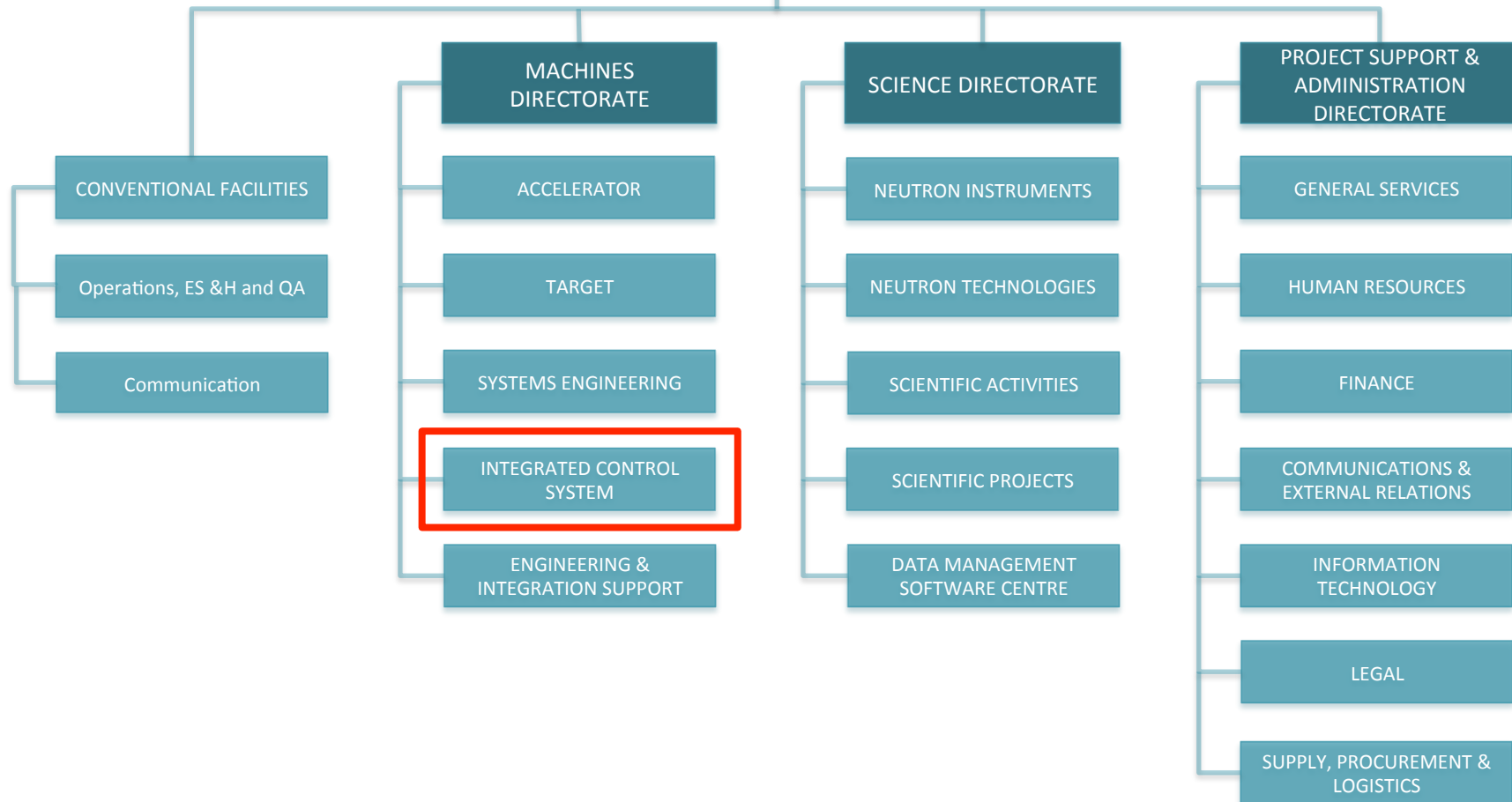

The ICS Handbook is

- A guide for ICS developers and users
- Contains technical standards and process descriptions
- Is not a monolithic “Bible” but refers to other documents for details
- Shall be relatively stable
 - Thus details are kept separate
- Aims to be complete
 - Contains pointers to all ICS services, policies and processes
- Is “Work In Progress”
 - Not yet in CHESS, but should be there soon

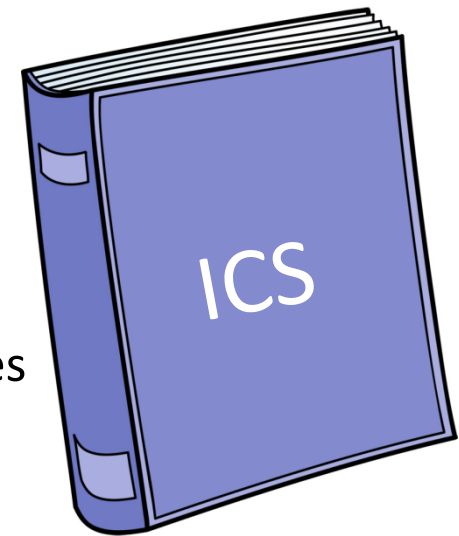

Contents #1

TABLE OF CONTENT	PAGE
1. INTRODUCTION.....	5
1.1. Purpose.....	5
1.2. Scope.....	5
1.3. Definitions.....	5
1.4. Related Documents.....	5
2. ICS DIVISION MISSION STATEMENT.....	6
2.1. Scope.....	6
2.2. Responsibilities.....	7
2.3. Documentation structure and references.....	7
➔ 3. SYSTEM DESIGN PHILOSOPHY.....	7
3.1. Introduction.....	7
3.2. Operation of the ESS Facility.....	7
3.3. System mandatory functional requirements.....	7
4. SYSTEM SPECIFICATIONS.....	8
4.1. Introduction.....	8
➔ 4.2. System Architecture.....	8
4.2.1. Connections between systems.....	9
4.2.2. EPICS.....	9
4.2.3. Timing Distribution.....	11
➔ 4.3. Naming Convention.....	11
4.3.1. Scope of the Naming Convention.....	11
➔ 4.4. System Software Standards and Specifications.....	12
4.4.1. Computing Infrastructure.....	12
4.4.2. Development Environment.....	13
4.4.3. EPICS development.....	14
4.4.4. Configuration Management.....	15
4.4.5. EPICS Services.....	16
4.4.6. User Interface tools (Control System Studio).....	16
➔ 4.5. System Hardware Standards and Specifications.....	16

- Overview of central requirements
- System architecture description
- Naming convention
- Software standards
- Computing infrastructure
- User Interface tools

Contents #2

4.5.1. MicroTCA.....	16
4.5.2. EtherCAT	17
4.5.3. PLCs.....	17
4.5.4. Other hardware and fieldbuses	17
4.6. Global Timing System Specification.....	17
4.7. ICS Network and Server Infrastructure specifications	17
➔ 5. INTERFACE SPECIFICATIONS.....	18
5.1. Introduction.....	18
➔ 5.2. Functional Interfaces.....	18
➔ 5.3. Physical Interfaces	18
5.3.1. Connecting I/O signals to ICS equipment.....	18
5.3.2. Standards for analogue signals	19
5.3.3. Standards for digital I/O	19
5.3.4. I/O through fieldbuses.....	19
5.3.5. Timing trigger standards.....	20
5.3.6. Beam interlock system I/O.....	20
5.4. Division of responsibilities related to interfaces	20
➔ 6. MACHINE PROTECTION SPECIFICATION	21
6.1. Introduction.....	21
6.2. Architecture.....	21
6.3. Naming Conventions.....	21
6.4. Software Specifications	21
6.5. Hardware Specifications.....	21
➔ 7. PERSONNEL SAFETY SPECIFICATION.....	21
7.1. Personnel Safety Architecture	21
7.2. Personnel Safety Software Specifications.....	21
7.3. Personnel Safety Hardware Specification.....	21
7.4. Personnel Safety lifecycle, and quality requirements.....	21
7.5. Standards and Guidelines.....	21
8. SYSTEM LIFE CYCLE	21
8.1. Introduction.....	21

- Hardware standards
- Timing system description
- System interfaces
 - Functional
 - Hardware
- Machine protection standards
 - Architecture
 - Interfaces
- Personnel Safety System
 - Architecture, SW, HW

Contents example 1

4.2.1. Connections between systems

In the control system, there are a number of networks or similar systems that connect system components together. **All** ICS systems that use EPICS are connected to the Ethernet network. **Most** systems receive timing signals from the central timing system and are thus connected to the Timing Distribution Network. **Many** systems, mostly in the accelerator, are connected to the beam interlock system.

Connections from the controllers to the physical I/O are can be directly from the (EPICS) I/O Controller (IOC) via either I/O cards (as in MTCA.4 AMCs) or via a fieldbus (e.g., EtherCAT, Serial RS-232 port or regular Ethernet). In many cases, I/O is connected to a PLC using the PLC vendor's modules and the PLC and EPICS IOC communicate via a dedicated Ethernet link.

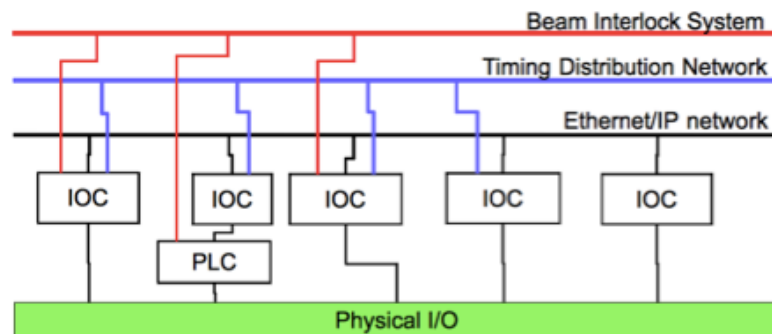

Figure 1 Connections between I/O Controllers

4.2.2. EPICS

All components in the control system that serve or access EPICS channels shall be connected to the network and use the pvAccess protocol to communicate. This setup is schematically shown in Figure 2. Please note that this picture is accelerator-centric. It does not describe all services and components that ICS will support but provides just a schematic overview of the architecture.

General overview(s) of the system architecture

- How are systems interconnected
- Different networks: timing, Ethernet, beam interlock (MPS)

Rules concerning use of EPICS

- What should be available in EPICS
- How do the systems communicate

Contents: example 2

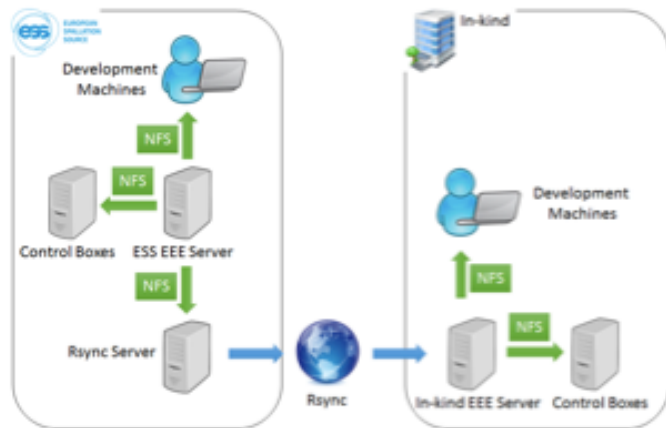

Figure 4.4.3. Schematic view of the development system and workflow.

4.4.3. EPICS development

At ESS, EPICS base, EPICS modules and parts of IOC **startup** are managed with a custom framework called the ESS EPICS Environment (EEE) [wiki at <https://ess-ics.atlassian.net/wiki/display/HAR/EPICS+Environment+Overview>]. The central functions of EEE are the following:

- Building and installing EPICS modules for multiple EPICS versions, architectures and operating systems.
- Managing all installed versions of EPICS and EPICS modules within a single environment.
- Choosing the versions of EPICS base and EPICS modules to build other modules against.
- Choosing the versions of EPICS base and EPICS modules that a particular IOC uses as part of IOC configuration.
- Resolving dependencies between EPICS modules at build time and IOC **startup** time.

The EEE framework has been designed to minimize the overhead of managing the above and provide a fast development cycle. EEE consists of the following components:

- EPICS development workflow
 - How to develop controls based on EPICS
 - Workflow and tools
 - System configuration
 - Development at ESS Lund and at in-kind collaborators
 - Delivery/integration to ESS
 - Code repositories, quality control, etc.

Status



- Preliminary document exists
 - Not yet ready for distribution
- A lot of “mapped content” exists already
 - Needs to be organized
 - Moved from Confluence to CHES, when appropriate
- Work will be distributed in ICS
 - To fill in the details
 - To review and approve contents
- Shall be **complete** in (roughly) 6 months from now
 - All essential items captured