

0. Abstract

We explore the impact of the moderator view of the vertical support structures in the plane of the neutron beams in the outer reflector. Typical and "worst-case" instruments are studied.

We find that the thin steel plate above the target wheel may serve a useful shielding function and we therefore do not recommend removing it.

By using the beam requirements of FREIA and BEER, we explore the maximum needed horizontal view of the moderator which in turn drives the allowable dimensions of the vertical support structures within the outer reflector. We find that the wedge-shaped structures do not interfere with the needed moderator view, but can even be slightly extended in the West and South sectors, though the thin blades stabilising the steel plate above the target wheel may need to be shortened. We propose that the beam requirements of BEER should be used to determine the maximum allowable dimensions of the support structures in question. The choice of their actual dimensions needs to be informed by a consideration of their shielding properties.

1. Introduction

The first neutron optical component of the instruments is the view of the moderators seen from the neutron beam port entrance windows at 2 m from the Target Centre Line (TCL). This view is defined by the dimensions of the moderators themselves, as well as the openings in the Moderator-Reflector (MR) plug (the inner reflector) and in the outer reflector which takes up the volume between the MR plug and the 2 m position.

The current report takes as its starting point the horizontal view permitted by the outer reflector. In particular, it relates to a series of vertical support structures shown in red in Fig. 1.

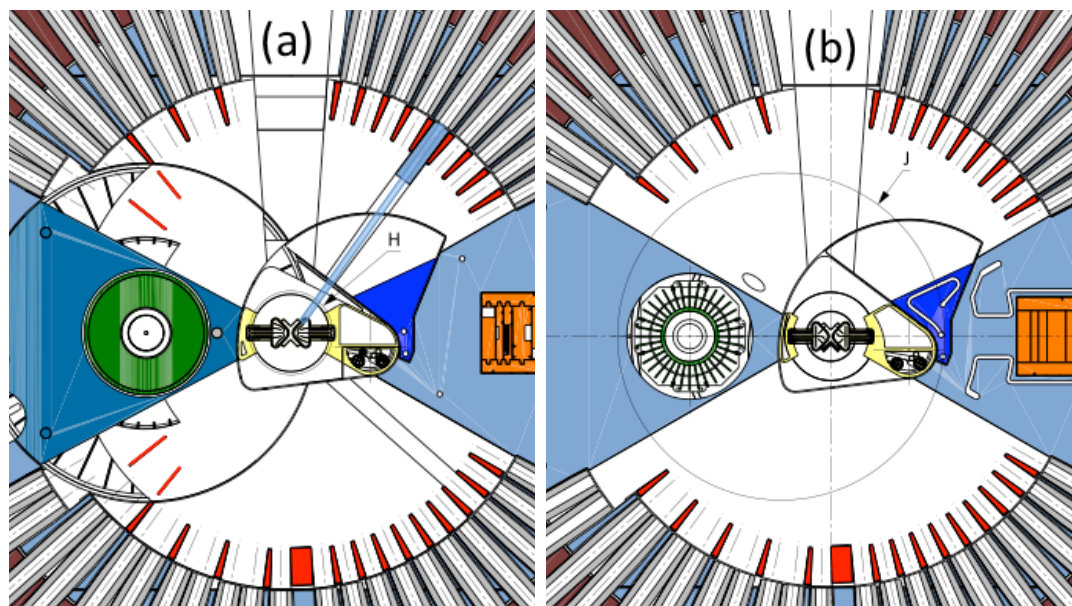

Fig. 1 horizontal sections through the centre of (a) the top moderator and (b) the bottom moderator. The vertical support structures are shown in red.

The structures shown in red serve a structural purpose: the wedge-shaped structures are required to support the weight of the upper half of the outer reflector. The four thin blades above the target wheel serve to maintain the shape of a steel plate mounted directly above the target wheel under the strain caused by thermal gradients. In addition to their structural purposes, these structures also improve the shielding of fast neutrons from the region of the neutron production volume in the target wheel; the wedge-shaped structures by attenuating the fast neutrons entering the beamports, the thin blades above the target by allowing the installation of the steel plate above the target which also serves as a shielding element.

2. Usefulness of the steel plate above the target wheel

The steel plate above the target wheel is shown in Fig. 2 below.

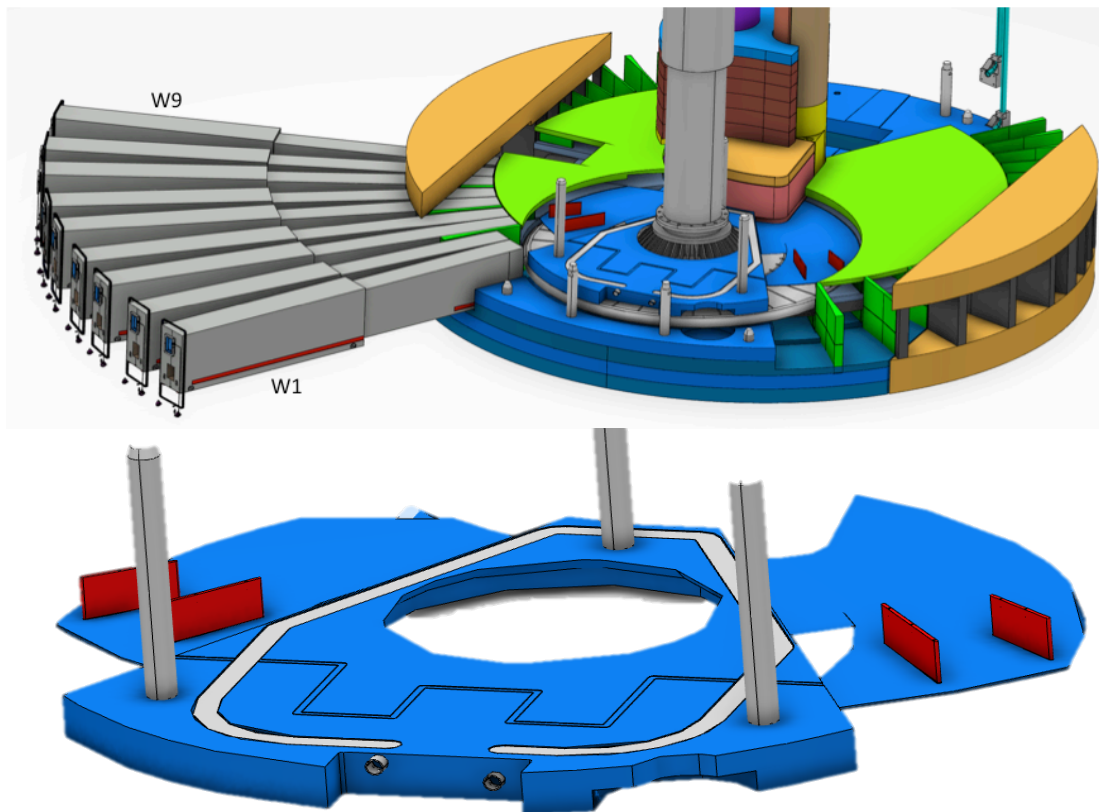

Fig. 2 Partially exploded view around the target wheel (shown in grey), showing the steel plate above the target wheel (in blue). The thin support structures visible in Fig. 1(a) are shown here in red.

The question was raised of whether this steel plate above the target wheel serves a useful purpose as a shielding element. Fig. 3 below shows a series of vertical cuts, going approximately from the TCL through the centre of the beamport insert for beamports W1, W3, W5, W7 and W9.

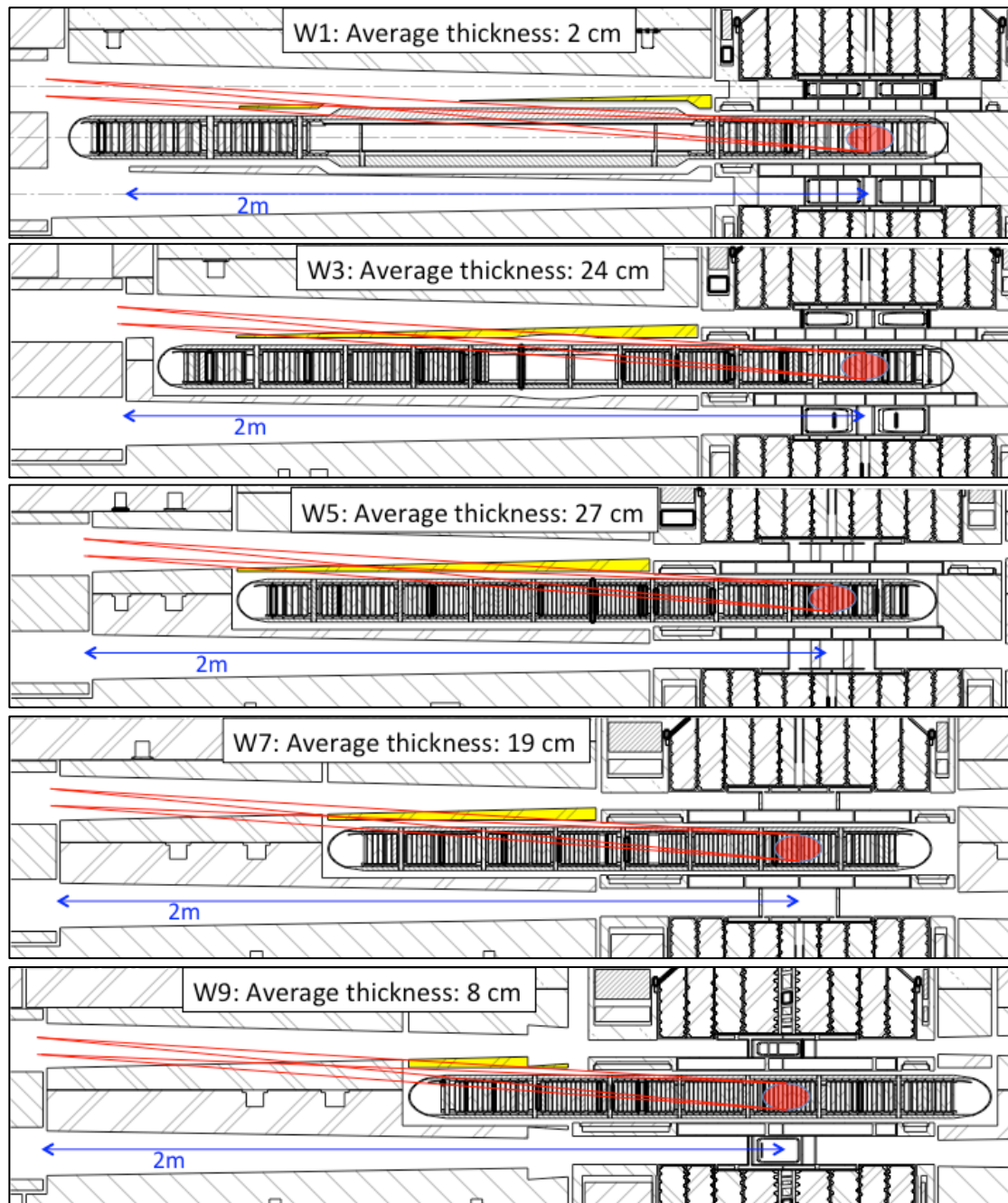

Fig. 3 vertical cuts through the W1, W3, W5, W7, W9 beam axes, with the steel plate above the target wheel of Fig. 2 highlighted in yellow. For each beamport, the neutron production volume in the target is shown as a red ellipse with red lines showing the extrema of the neutron trajectories between the neutron production volume and a typical guide entrance of about 5 cm in height. The average thickness through the steel plate is calculated as the average of the four trajectory lengths shown through the yellow volume.

For each of the beamports shown, an estimate has been made of the average thickness of material traversed through the steel plate in question between the neutron-production volume of the target wheel and the guide entrance, as shown in Fig. 3. It varies between 2 cm for W1 up to 27 cm at W5. This is to be compared with the 90% attenuation length (or "1/10 length") for steel which is of the order of 10-50 cm for fast neutrons in the MeV to GeV range [1]. We conclude that the steel

plate in question may serve a useful shielding purpose, as its thickness along the trajectories of the fast neutrons is comparable to the thickness needed to attenuate their intensity by a factor of 10. However, fast neutrons following the trajectories shown in Fig. 3 do not have a direct line-of-sight through the hole in the beamport insert. They contribute to the background outside the monolith by scattering, absorption and creation of secondary particles. Quantifying the effect of the steel plate in question therefore needs expertise in shielding which falls outside the scope of this report.

3. Geometry of support structures in the outer reflector

We will now estimate how wide the wedge-shaped structures in Fig. 1 can be made without interfering with the horizontal view of the moderators from the beamport entrance. The boundary conditions for this study are the widths of the viewed moderator surfaces and the guide widths at the entrance of the beamport insert at 2 m from the TCL. The viewed moderator surfaces are illustrated in Fig. 4 below.

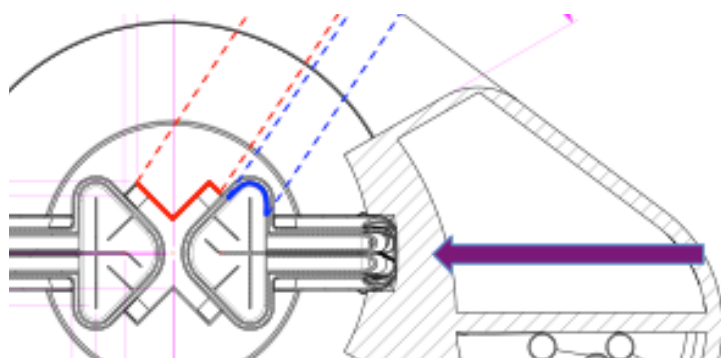

Fig. 4 Width of the viewed surfaces of the thermal (red) and cold (blue) moderators, illustrated for one of the beamports in the North sector. The direction of the proton beam is shown as the purple arrow.

The guide width at the entrance of the beamport is different for every instrument. A study of how some of the instrument guides can be accommodated within the current design for the beamport insert is given in [2]. This study examined LOKI, FREIA and SKADI, which at the time were considered to be the most demanding in terms of guide width inside the beamport insert, due to their strong horizontal curvature. A minimum offset of 40 mm between the outside surface of the beamport insert and the inside surface of the neutron guide was used as a boundary condition and was found to allow good performance of these three instruments. This has resulted in a guideline being issued that all instruments should constrain their guide to lying within an envelope of 90 mm width at the beamport entrance, centred on the beamport axis.

Since then, however, the change of moderator geometry (from pancake to butterfly) and the definition of the beamport axis focal points [3] has meant that all instruments will need to have their guide tilted or shifted (or both) with respect to their beamport axis. This will affect the width reserved for the guides within the beamport insert and means that the conclusions of ref. [2] need to be revisited.

A compilation of the currently expected guide geometries for the instruments has been made as part of the effort to define a new baseline for the instrument layout

[4]. A survey was made of this compilation and it was found that there are two types of instrument which place the most difficult requirements on the envelope needed for the guide at the beamport insert entrance: (a) cold instruments with a strong horizontal curvature and (b) bispectral instruments employing a reflecting bispectral switch. By "difficult" in this context, we mean that the one or both of the sides of the guide window is far from the beamport axis.

3.1 Cold Instruments

The cold instrument with the strongest horizontal curvature and largest guide width at the moment is FREIA. Its guide is 50 mm wide and curves horizontally with a radius of curvature of 56 m [5]. Fig. 5 shows two possible implementations of the FREIA guide. They correspond to angles of 0.8° (top) and 1.8° (bottom) between the beamport axis and the direction of the guide entrance, chosen to illustrate the range of possible implementations. In order to study the worst-case scenario, it has been placed at the 90° (beamport S11) position where the projected distance between the focal point of the beamport axis and the centre of the cold moderator is maximum.

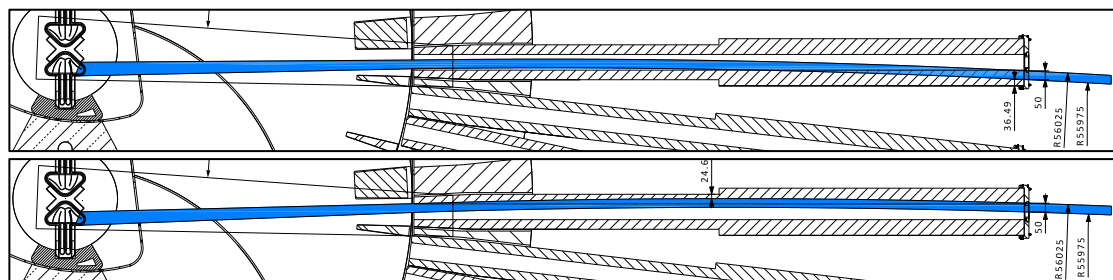

Fig. 5 Range of implementations of the FREIA guide on beamport S11. Top frame: guide entrance at 0.8° to the beamport axis. Bottom frame: guide entrance at 1.8° to the beamport axis.

It is seen in Fig. 5 that in neither of the two cases will the view of the cold moderator on FREIA be obstructed by the wedge-shaped structures. We therefore conclude that they do not cause a problem for the strongly-curved cold instruments.

3.2 Bispectral Instruments

There are currently 5 planned bispectral instruments: BEER, ODIN, T-REX, MAGIC and DREAM. Taking into account that the beamport allocations are not yet fixed and that we need to allow for future additional bispectral instruments, we consider that a beam extraction solution should be envisaged which allows both for future flexibility and the mechanical stability of the monolith.

The common feature of all the beamports is that their central axis points at the junction between the thermal moderator and the cold wing. We therefore define a transversal direction x shown in Fig. 6(a) which is positive on the side of the thermal moderator and negative on the cold side. For simplicity, the moderators are assumed to be wide compared to the wide allowed by the beamport insert.

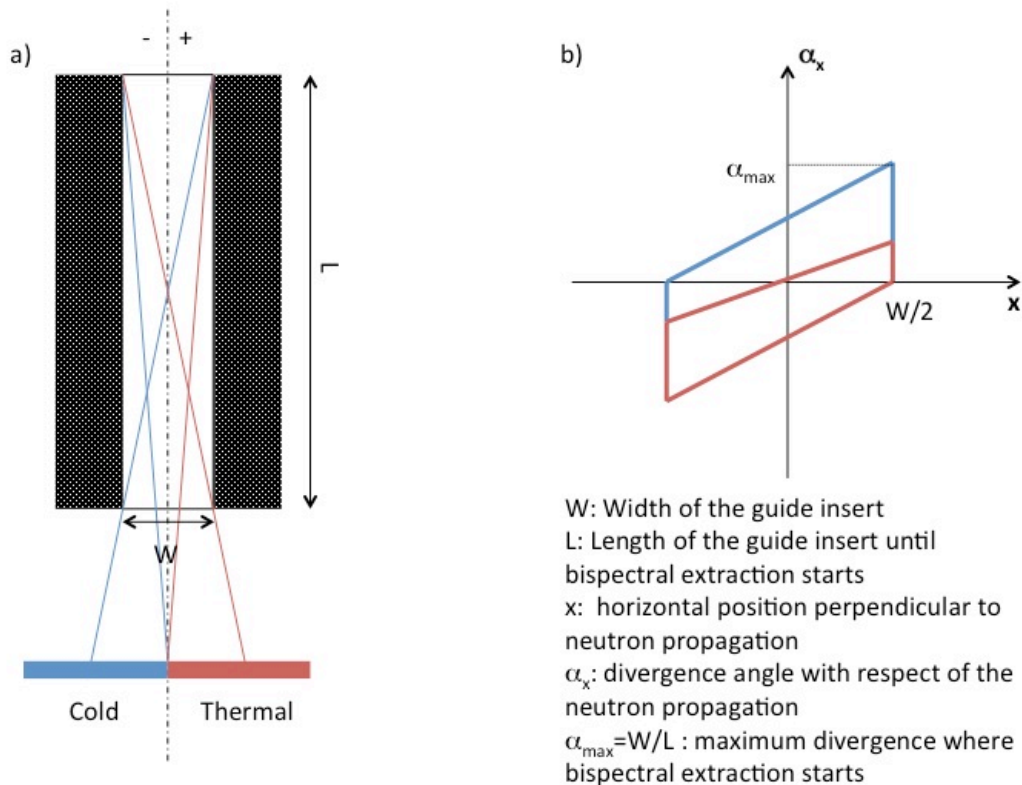

Fig. 6: a) Simplified sketch of a beamport with all the parameters. b) Phase space of the neutron beam at the bispectral extraction position.

Figure 6 a) shows a simplified sketch of a beamport which has a width W and the length of the beamport until the bispectral extraction system is L . In fig. 6 b) we show the phase space of the neutron beam before entering the bispectral extraction distinguishing the volume coming from the cold side and from the thermal side of the moderator.

For bispectral extraction, the beam has to be centred on the thermal moderator, and in this case this would be obtained if we take the left side of the phase space volume, i.e., the half of the beamport that is on the side of the thermal moderator.

Once the general rule has been derived, it can be compared with the designs proposed in the aforementioned instruments, which are sketched in Fig. 7. All the instruments are seen to have a bispectral extraction system of around 5 cm in width, pointing at the thermal moderator.

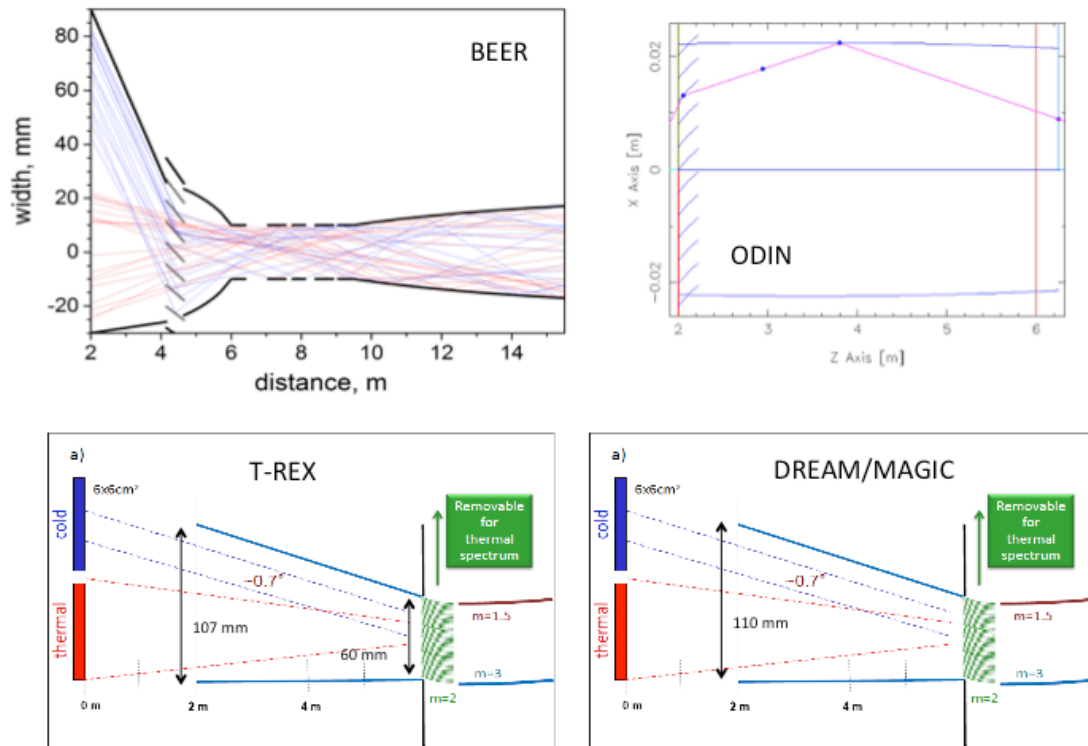

Fig. 7 Sketches of the bispectral beam extraction geometries for BEER, ODIN, T-REX, MAGIC and DREAM.

Of the five bispectral instruments, the most demanding is BEER with a guide entrance width of 120 mm at 2 m. We therefore decided to use this as a "worst-case" example. The maximum required view of the moderator for a bispectral instrument is sketched in Fig. 8 below.

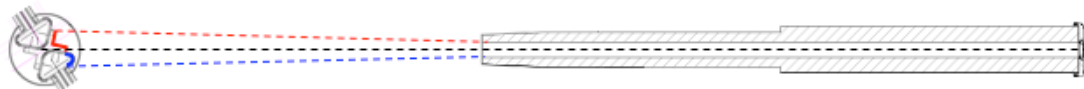

Fig. 8 Illustration of the required view of the moderator for a bispectral instrument. The dashed black line is the beamport axis, pointing to the junction between the cold and thermal sources. At the entrance of the beamport insert, the red and blue dashed lines indicate the width of the guide (which is not necessarily centred on the beamport axis). The red and blue dashed lines originate from the edges of the thermal source and cold sources, respectively, indicating the region which needs to be kept free of obstruction in order to allow an unimpeded view of the moderator.

The area delineated by the red and blue dashed lines in Fig. 8 allows a view of the full width of the thermal and cold sources seen from the full width of the guide entrance at the 2 m position. Fig. 8 shows this area in blue, calculated for the BEER guide requirements and reproduced on all beamports.

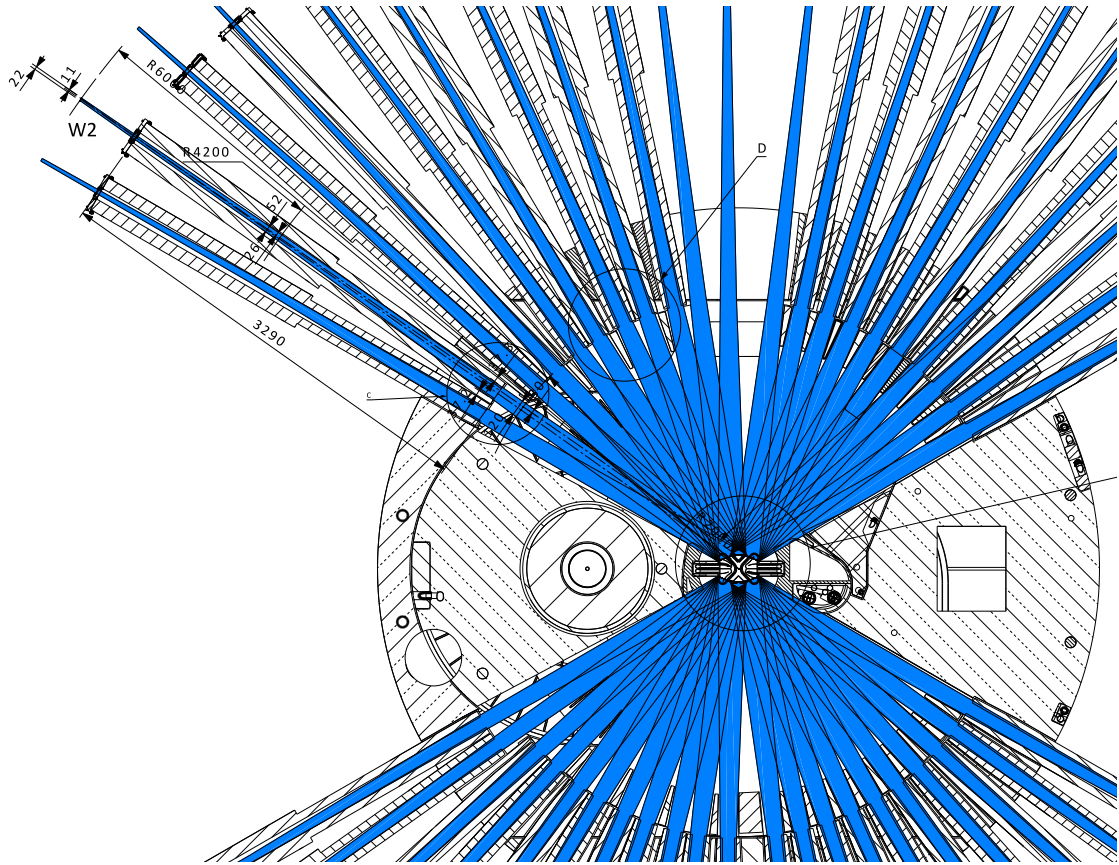

Fig. 9 Space reserved for the moderator view needed for BEER on all beamports.

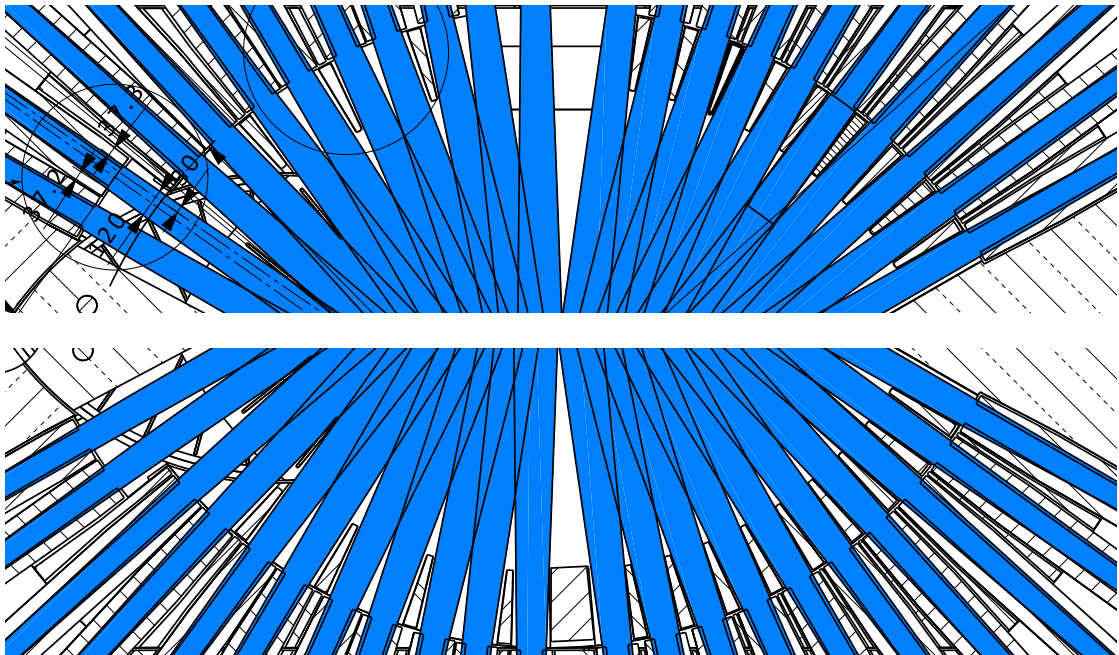

Fig. 10 Close-up of the wedges from Fig. 9.

As can be seen in Figs. 9 and 10, none of the wedge-shaped structures interfere with the view of the moderators. In the North and East sectors, they would start to block the view if they were made any wider. In the West and South sectors, they could be increased slightly in width without interference. In all cases, they could be slightly extended along the beam direction, particularly in the West and South sectors.

The thin plates which serve to stabilise the plate shown in Fig. 2 appear to cause a small amount of obstruction and should be shortened slightly.

How much of a shielding function is performed by the support structures shown in red in Fig. 1 has not been properly addressed here. That question needs to be studied by the competent shielding experts. We propose that the method used here of employing BEER as worst-case scenario is used to determine the maximum allowable dimensions of these structures. The choice of their actual dimensions needs to be informed by a consideration of their shielding properties.

References

- 1 Stuart Ansell, private communication, 18/12/2015
- 2 Beam Insert Horizontal Feasibility, P.M. Bentley, 27/10/2014
- 3 ESS-34251 and ESS-32315.3
- 4 Benjamin Davidge, private communication, 12/11/2015
- 5 FREIA proposal