NBGI Port Integration Design

	Name	Role/Title
Owner	Jarich Koning	Remote Handling expert
Reviewer	Cock Heemskerk	
Approver	Rikard Linander	

TABLE OF CONTENT	PAGE
1. INTRODUCTION.....	6
1.1. Considerations	6
2. DESIGN.....	8
2.1. Bridge beam guide assembly	8
2.2. Light Shutter - GBS	10
2.3. Shutter actuator.....	11
2.4. Neutron beam vacuum windows	12
2.5. Double sealing flange	13
2.6. Compression spider.....	14
2.7. Helium leak testing.....	15
2.7.1. Permanently integrated option.....	15
2.7.2. Remotely operated tooling providing helium.....	15
2.8. Vessel-side features of the NBseal	16
2.9. Extra shielding.....	18
2.10. Bunker roof shielding support pillars.....	19
2.11. RH compatible bolts	19
2.12. Horizontal cask approach.....	20
2.13. Remaining issues.....	22
3. VERTICAL HANDLING APPROACH.....	23
3.1. Introduction.....	23
3.2. Configurations.....	24
3.3. Use cases and resulting configurations.....	25
3.3.1. Upper-channel instrument.....	26
3.3.2. Lower-channel instrument.....	26
3.3.3. Mid-position, larger cross-section channel	26
3.3.4. Bi-channel instrument.....	26
3.4. Rigid chain actuator.....	27
3.5. Further motion concept.....	29

3.6. Block locking system..... 30
 3.7. BBG engaging system 31
 4. HANDLING SEQUENCES 33
 4.1. Preparation..... 34
 4.2. Installation of the NBS 35
 4.3. Installation of the GBS 36
 4.4. Removing shutters 37
 4.5. Removing the flange assembly..... 41
 4.5.1. Bolting carriage 42
 4.5.2. Flange assembly handling carriage..... 44
 4.5.3. Sealing surface polishing and inspection carriage 47
 4.5.4. Helium leak testing carriage..... 48
 5. GLOSSARY 48
 6. REFERENCES..... 48
 DOCUMENT REVISION HISTORY 49

LIST OF TABLES

No table of figures entries found.

LIST OF FIGURES

Figure 1 Overview of the bunker area with one port filled. Bunker beamlines not included. 6
 Figure 3 Four states of the NBGI port (left to right): With guides (operational), with shutter closed (normal non-operational), seal flange exposed (for seal flange and/or insert exchange), with seal flanges removed (only insert with windows). 8
 Figure 2 Cross sectional overview. Actuator down in basement. Monolith on right..... 8
 Figure 4 Bridge Beam Guide assy in operational position (light-green) on insert (gray) housed in cradle (translucent-light-brown) 9
 Figure 5 Shutter with steel (light-blue) and tungsten (blue) volumes 10
 Figure 6 Example of rigid-chain actuator, with four-level storage cassette 11

Figure 7 BBG (light green) in cradle (brown) on insert (light brown) with vacuum window (green) visible.....	12
Figure 8 Kinematic mount arranged around vacuum window.....	12
Figure 9 Double sealing flange cross-section.	13
Figure 10 Cooling connection lines (highlighted blue) integrated in the spider. He leak testing line (top, right) highlighted, too.	14
Figure 11 Left: cross-section showing flanged connector and distribution to the outer seal ambient side. Right: planar cross-section showing helium feed for leak detection from outer to inner flange (line should have more flexibility in the future).	15
Figure 12 Left: updated seal assembly with an extra helium feed connector on the top-right. Right: Top bit of the vessel docking surface shown, with RH inserts (orange) and their locking pins visible.	16
Figure 13 Cross-section of the large helium feed compliant stub. The oversized holes and the RH bolts with aligning nose, will combine to self-align the vessel side flange to wherever the flange on the spider might be.	17
Figure 14 Version of the assembly with orange, permanent, shielding between and above ports. There is a 390mmx494mm wide handling area at all ports. The bit above the ports extends out of the R6000mm.....	18
Figure 15 The orange shielding (translucent here) can house shutter(s); the shielding is 'wrapped around' the bunker roof support beams (green-blue). Shutter(s) can be stored in the floor as well.	18
Figure 16 RH compatible bolt. The hole in the purple flange is threaded, thus making the bolt captive. This style is used at the inner seal flange.....	19
Figure 17 Another style of captivity using a snap-on ring, used in the outer sealing flange. This allows bolts to have more radial clearance	20
Figure 18 Example positioning of actuators in the basement. Radial in the East and South sectors – which is incompatible with casks – tangential and at various angles in the Nort and West sectors. Not all actuator locations can be occupied by an actuator at the same time.....	27
Figure 19 Nort and West sectors in basement services by two actuators (position tangent to circle) on circular rails.....	28
Figure 20 Rigid chain actuator with sketched storage in R5275 to R5500 area. The storage is to be extended vertically as much as necessary.....	29
Figure 22 Horizontal cross-section (about target level) showing engaging of the block locking system. Top-left: locked situation (green block), top-right: rod with extension is inserted and rotated till it meets the block, lower-left: rod is further rotated to disengage the block; lower-right: the rod	

Document Type Report
Document Number ESS-0044607
Date Apr 29, 2016
Revision 3
State Released
Confidentiality Level Internal

is further rotated and removed. Optionally it can make a full circle to double-check the disengagement. 31

Figure 23 Horizontal cross-section (top pictures), upper moderator level, showing engaging the BBG by stamp linkage. Left: disengaged. Right: engaged. Notice the subtle, 5mm forward motion of the BBG. The lower pictures are a cross-section through the linkage (green)..... 32

1. INTRODUCTION

The scope of this document concerns the area just outside the monolith proper, from target point measuring R5.5m to R6m area at target level, including the vacuum-to-ambient-air transition and handling interfaces. This area, the 'port', serves the neutron beams, safety, handling functions and is tightly packed. The intended audience is monolith, vacuum and bunker engineers, including possible users of beamlines.

The beamlines can see the area as a 'bridge' from the monolith into the bunker.

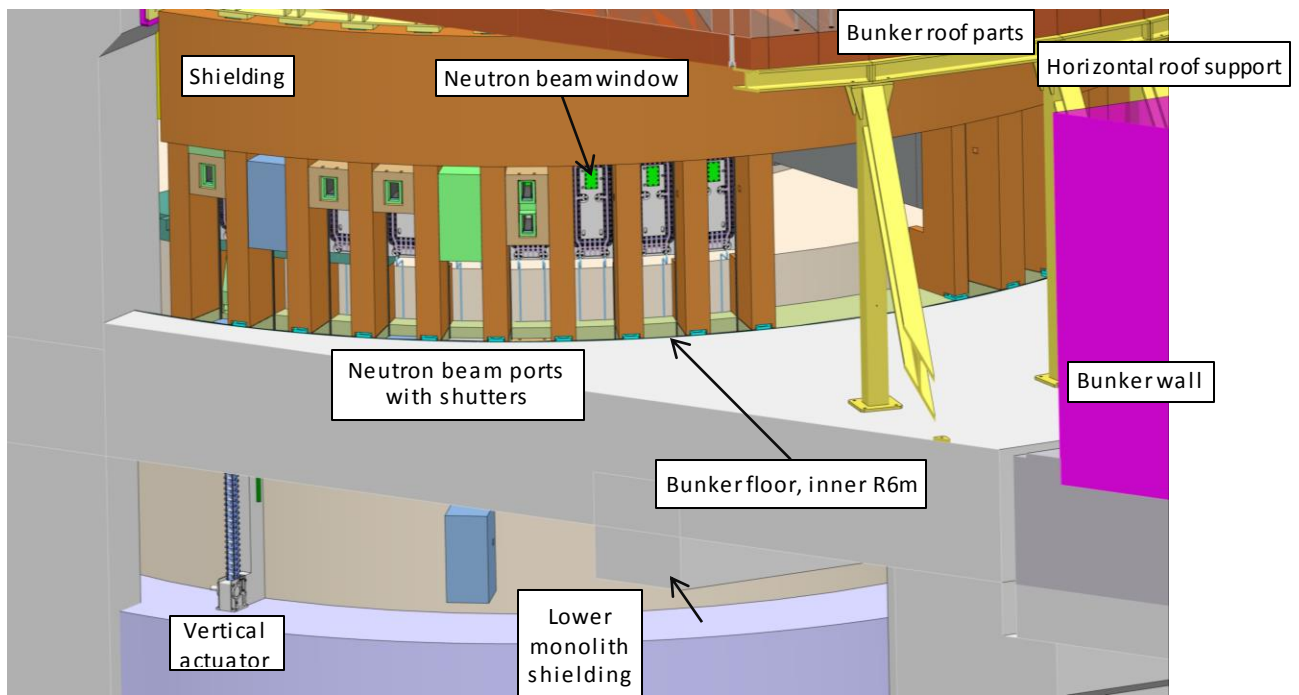

Figure 1 Overview of the bunker area with one port filled. Bunker beamlines not included.

1.1. Considerations

- Limited sideways space
- Support of bunker roof
- Keep material activated during operation low.
 - Exact activations levels unknown, try to implement as much options as possible
- Create low-radiation conditions during shutdown
 - Remove the bridge guide part
- Block straight target view during shutdown by a shutter
 - Without using >R6m area as beamlines should be able to remain.
- Shutter and possibly the bridge beam guides shall be removable to the lower basement.
- Accurately position bridge beam guide(s) to insert, <0.1mm
- Support insert push-in force of about 40kN total

Document Type	Report
Document Number	ESS-0044607
Date	Apr 29, 2016
Revision	3
State	Released
Confidentiality Level	Internal

- Avoid or confine oil, fats and carbon
- Prevent cross-contamination
 - Dust, carbohydrates from ambient air in to vacuum vessel
 - Radioactive contamination from vessel to bunker
- Support cask-based handling of vacuum flange possibly including window
- Support NBEX tool docking
- Integrate high-vacuum to ambient transition boundary
- Fail-safe environment
 - Keep actuators and electronics out of the area wherever possible
 - Anything which can break shall be replaceable (RH or hands-on) or the subject should be salvageable (RH or hands-on)

2. DESIGN

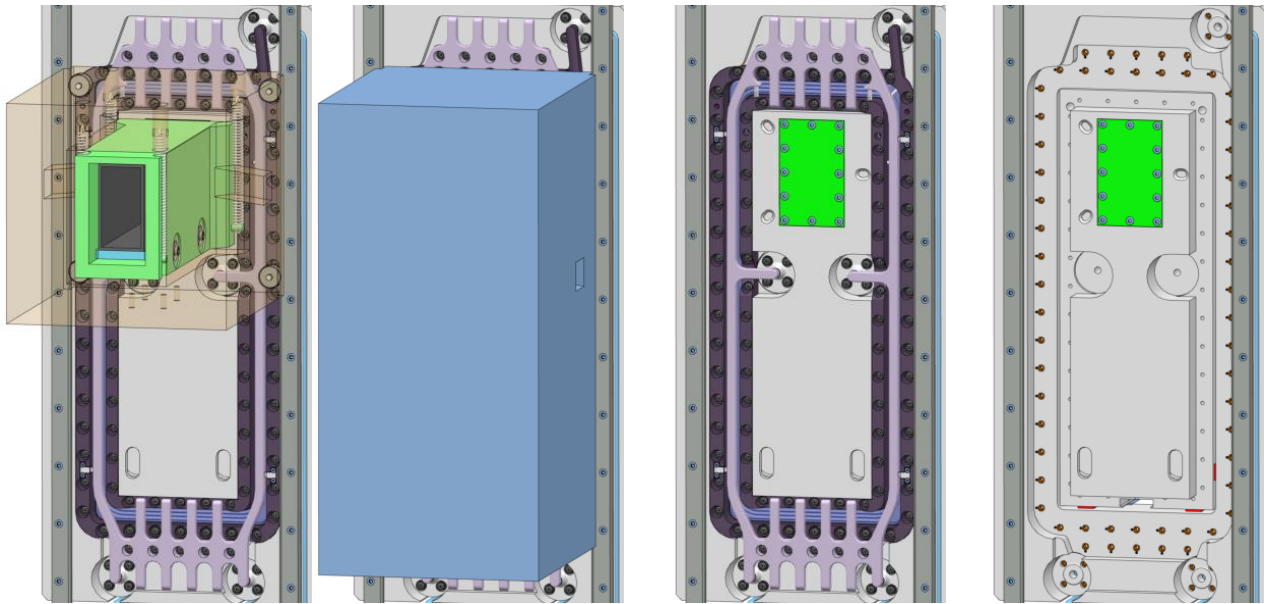

Figure 3 Four states of the NBGI port (left to right): With guides (operational), with shutter closed (normal non-operational), seal flange exposed (for seal flange and/or insert exchange), with seal flanges removed (only insert with windows).

Figure 3 presents four states of the port design close up. Figure 2 gives a vertical cross-section overview of the whole system. The permanent features of the flange are completely flush with the port block flange.

2.1. Bridge beam guide assembly

The beam guide mirrors normally require a mirror-to-mirror accuracy of $<50\mu\text{m}$. Therefore the BBG assembly has been conceptualized, separating the heavy gamma shutter body with no specific accuracy requirement, from this assembly with highly accurate mounting requirement. Care has been taken to design an example interface, as for each port this assembly will look different. The example design integrates a clean 6DoF kinematic mount with three-spheres-in-three-V-grooves, and providing the possibility to design a stiff structure towards the mirror mounts, with ample space to integrate mirror alignment aids. As a concept, a very short stroke differential screw is integrated on the two beamlines.

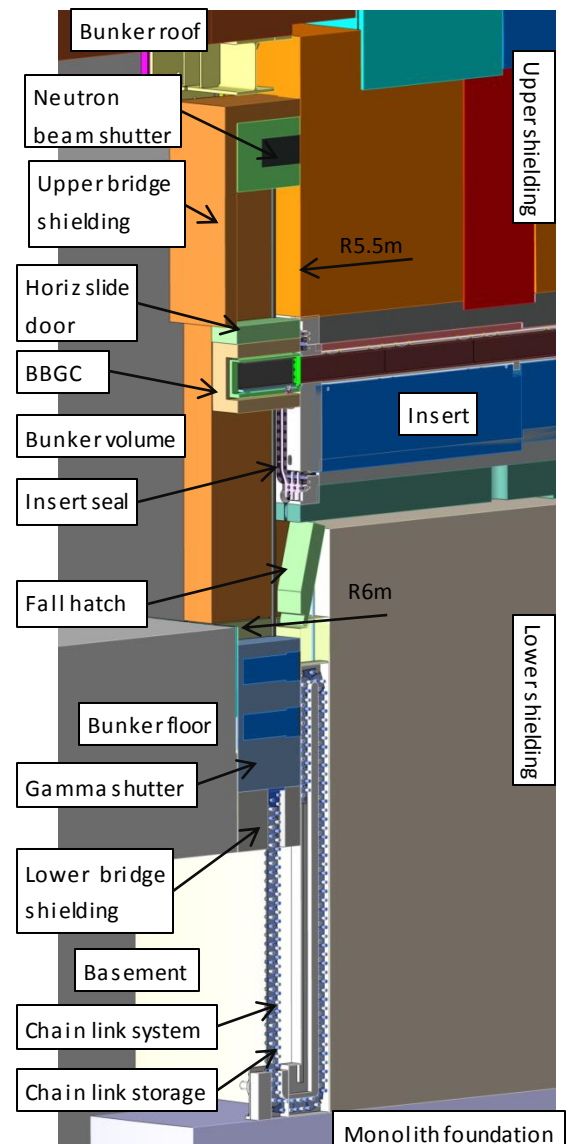

Figure 2 Cross sectional overview. Actuator down in basement. Monolith on right.

The kinematic mount is based on three spheres in three V-grooves (3 times two DoFs). This allows positioning the thermal centre line at the intersection point of the V-grooves. The mount is engaged by a 50deg force actuated by a mechanical linkage. This allows positioning the actuator in the basement, away from radiation and thereby avoiding difficult rescue scenarios.

The cradle has springs integrated compensating gravity

The temporary removal of the bridge beam guide assembly starts by disengaging the force linkage, then actuating the vertical chain-link actuator to move the shutter up or down. Depending on the configuration of blocks on the rails, the vertical actuator can then move one of the shutters.

Replacing the BBG for a new one is possible; if the shutter is brought fully down into the basement, it can be removed in a cask. The shutter(s) and/or floor blocks travelling on the rails can be removed in the same manner. If the activation is low (as with a separate gamma shutter should be possible), the block can even be removed from the lower end of the rails without a cask. This is illustrated in the handling sequences in Chapter 4.

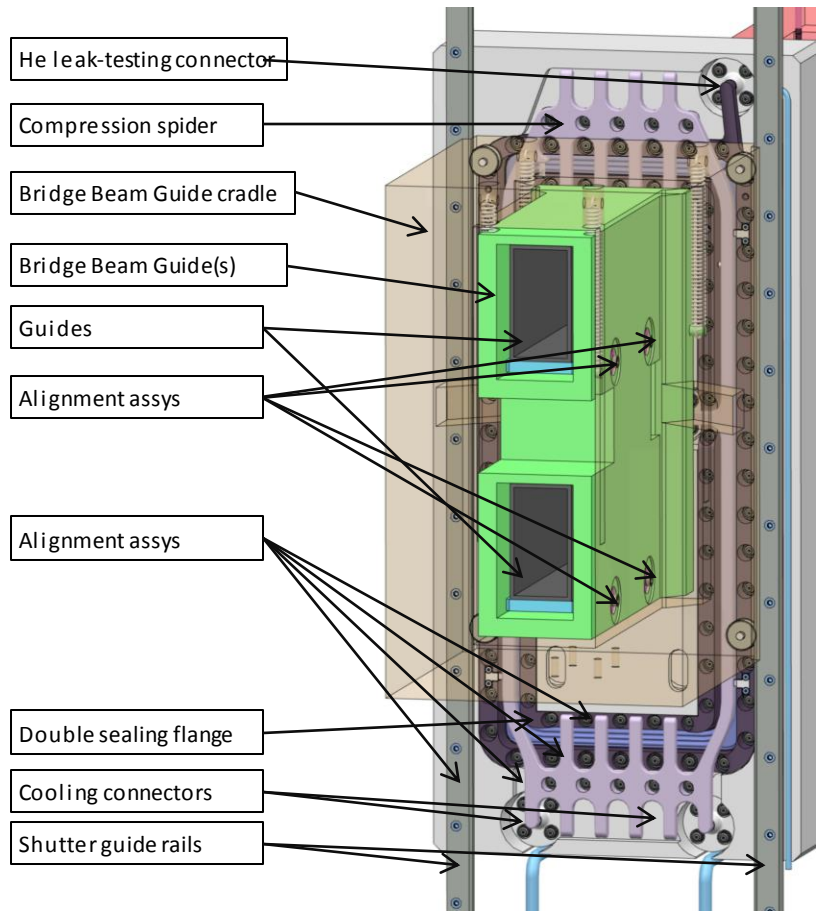

Figure 4 Bridge Beam Guide assy in operational position (light-green) on insert (gray) housed in cradle (translucent-light-brown)

2.2. Light Shutter - GBS

The (Gamma Beam) shutter (GBS) is to provide gamma shielding during shutdown; the straight beamline volumes are to be shielded by a tungsten block, and stainless steel is required around it to catch most of the scattered gammas. The block is some 60mm larger at all sides than the slit around the NBPI, to shield off gamma radiation coming from the core monolith. The volume of this block means for most beam ports the mass of the shutter will be around 1500kg. Tungsten activates under neutron radiation and stays hot for a long time; therefore the shutter shall be removed from the open bunker during operation. In the design concept the shutter can

- 1) Move upwards to a shielded area
- 2) Sink into the floor, where a (concrete) shielding bridge blocks provide a matched form for the shutter.

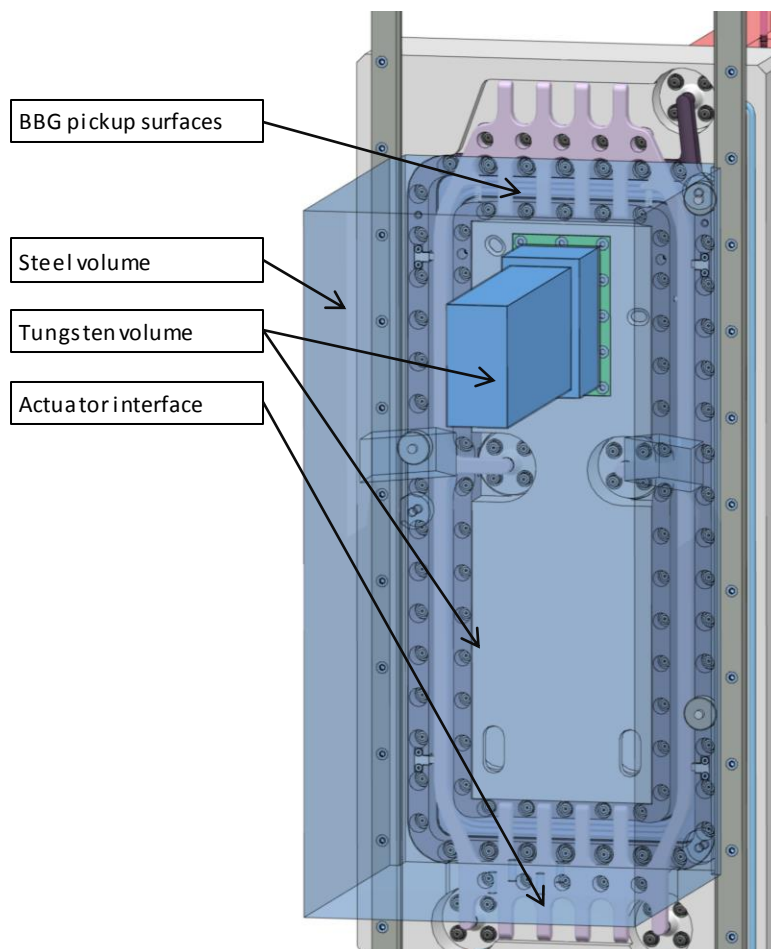

Figure 5 Shutter with steel (light-blue) and tungsten (blue) volumes

If necessary the shutter could be allowed to sink fully down into the basement, but most likely the bridge volume of the bunker floor will then have to be backfilled with a dumb concrete block. Guiding of the vertical shutter motion is performed by two rails mounted left and right; the shutter has wheels integrated. The clearance of the shutter versus the vessel is 1mm. The 'overlap' of the shutter with respect to the slits along the insert is about 60mm at all sides.

2.3. Shutter actuator

The previous shutter actuation system was a chain on a vertical support beam with locking features for the different stages of the motion, and a locking motor engaging the shutter on a semi-kinematic mount. The chain system and support beam used a lot of space which were not available for shielding nor for integrating a good vacuum flange. The current design focuses on minimizing the volumetric footprint of the actuation system in the port area. While a screw-spindle, or an hydraulic cylinder seem obvious motion concepts here, the stroke of some 2m is actually too long to store a single-stage cylinder into the basement. A telescopic cylinder would still be possible, but if it would ever fail in extended condition, it would not be retrievable from the basement.

Remaining options, disregarding options where the actuator sits on the moved item, are a scissor-style lift, or a rigid-chain (push-chain) system (see concept in Figure 2 and section 3.2). The latter is compact in horizontal footprint at the payload end, and integrates very well in the given space. Furthermore the force and length requirements match with the range of the most prominent commercial supplier (Serapid, Figure 6, more information in 3.4).

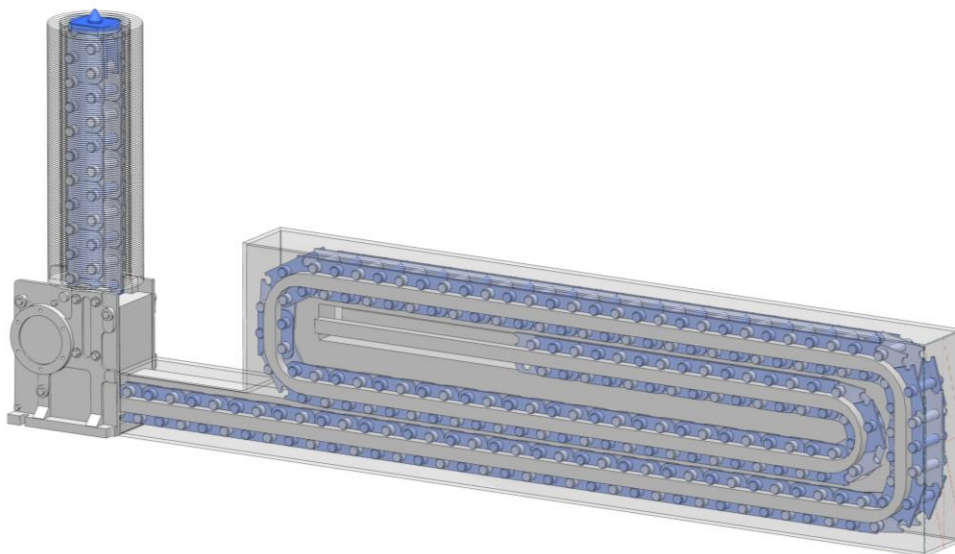

Figure 6 Example of rigid-chain actuator, with four-level storage cassette

The chain will need lubrication. If confinement of lubrication is necessary this can be realised by applying a gaiter (extendible, bellows-like plastic bags sealed to the end-effector), as in Figure 6. However, this comes at the cost of a larger cross-section of the actuator, meaning that it does not make sense to move it through a small hole in the fill blocks anymore. That means, whenever it actuates things on target level, first it has to remove the floor filler block(s), or if a gamma beam shutter is stored in the floor space, it can be moved upwards directly. The GBS then engages to the next block (BBGH probably) and can leave that in the high end of the rails.

2.4. Neutron beam vacuum windows

Even though these windows are in scope for the insert design, their positioning and mounting directly influences the port design. An example beamline location is integrated (Figure 7). The kinematic mount is arranged directly around the vacuum window.

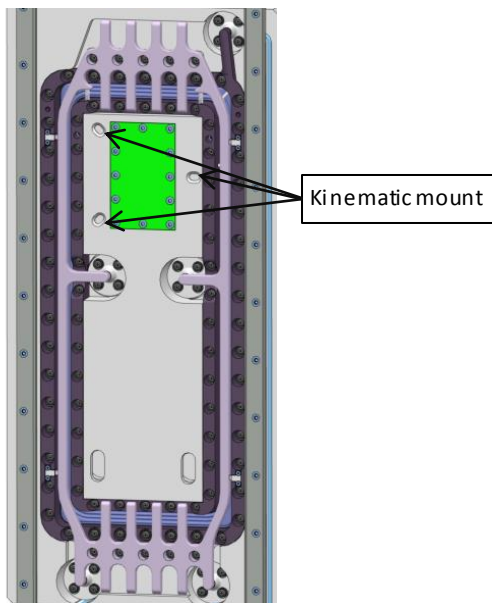

Figure 8 Kinematic mount arranged around vacuum window

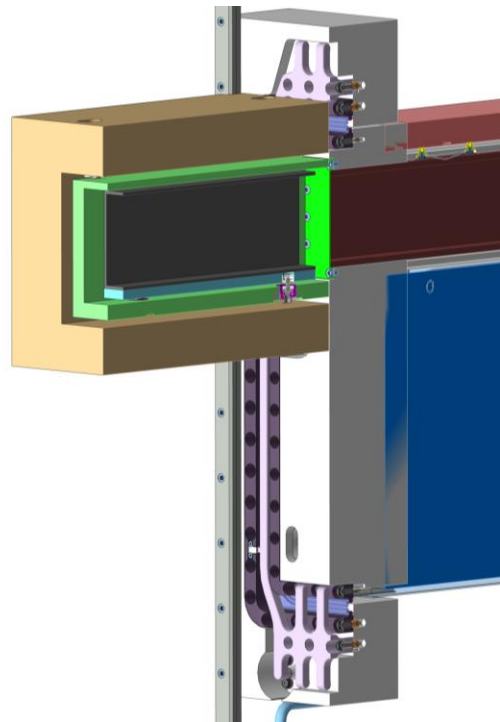

Figure 7 BFG (light green) in cradle (brown) on insert (light brown) with vacuum window (green) visible

2.5. Double sealing flange

This double flange has a flexible bellows between it. The bellows are lip-welded to both flanges. The flanges are minimally 20 mm thick, and at least every 50 mm an M8 bolt is integrated to provide enough pressure on the deformable wire-seal of $\varnothing 2.5$ mm. The bolts are of an RH compatible design (refer to section 2.11). The bellow integrated should support about 2bar max pressure difference, and an axial motion of about 2 mm. This value corresponds with the maximum temperature difference over the full length of the insert.

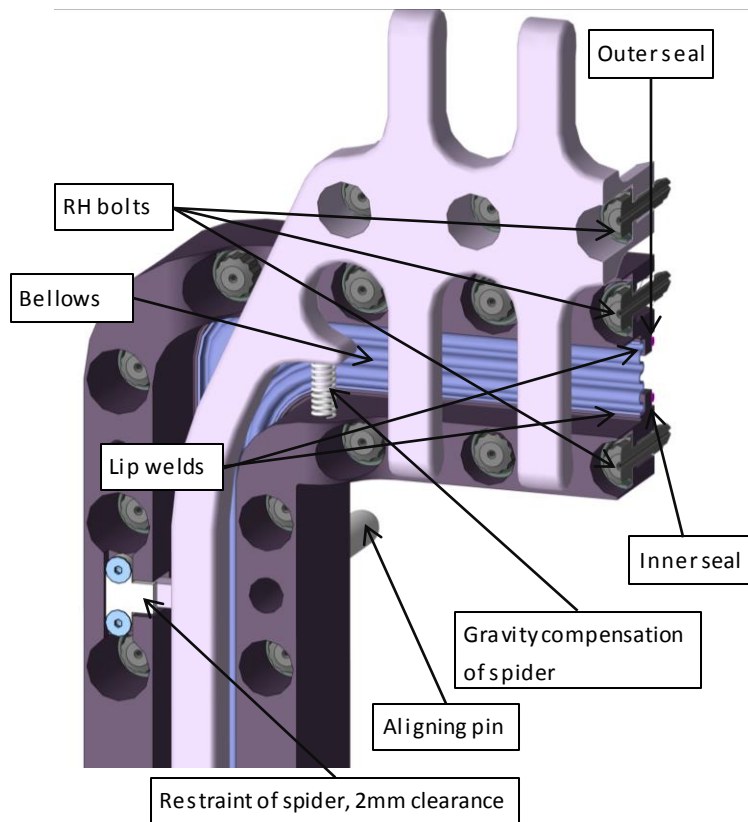

Figure 9 Double sealing flange cross-section.

Seal leak rates on vacuum vessel level need to be calculated, accorded with the vacuum group. Physical seal retainment onto the flanges needs to be designed, bellows need to be calculated. Finally the overall design and handling concept need to be hardware-mock upped as there are many subtle features influencing a robust result.

2.6. Compression spider

The sealing flange assembly integrates a sub-assembly (Compression spider in Figure 4) which fulfils two primary functions: pushing the insert forward so that the insert is properly constrained and through force-constraining it will accurately position against dedicated interfaces. Secondly the spider integrates two cooling connection lines, which are the feed-in and feed-out of the insert.

The spider is contained within the sealing flange assembly by four small studs. These offer ± 2 mm play in all directions, allowing the spider to align itself differently as compared to the sealing flanges. The XY (sidewards/upwards) alignment of the spider will be mainly driven by the cooling line connectors. Between the connectors the line shall exhibit perhaps a bit more compliance than currently integrated. Forward the constraint in mounted position will be against the vessel interface with 2 rows of 5 M8 RH-compatible bolts. The full torqueing of these bolts will elastically deform the spider fingers that contact with the inner sealing flange for approximately 2 mm, which will yield in total about 40 kN forward force.

The flanged connector mounted on the end of the cooling feeds (Figure 10) are a standard DN10 PN6 type 11b weld-on flange according to EN 1092-1:2007. Some adaptations are required:

- The flange on the removable part of the line shall contain the seal so that it is replaced if the assembly is replaced.
- RH compatible bolts M8 shall be used (normally M10 in this flange) to be common with the other bolts. The RH bolts shall therefore have a higher strength spec to compensate
- The containing of the RH bolts requires changes to the flange at the spider side, as well
- On the vessel side the female thread shall be in the connector flange. With the line compliance, the vessel-side flange can always properly engage to the spider-side flange. This also allows the spider to align to the insert-flanges.

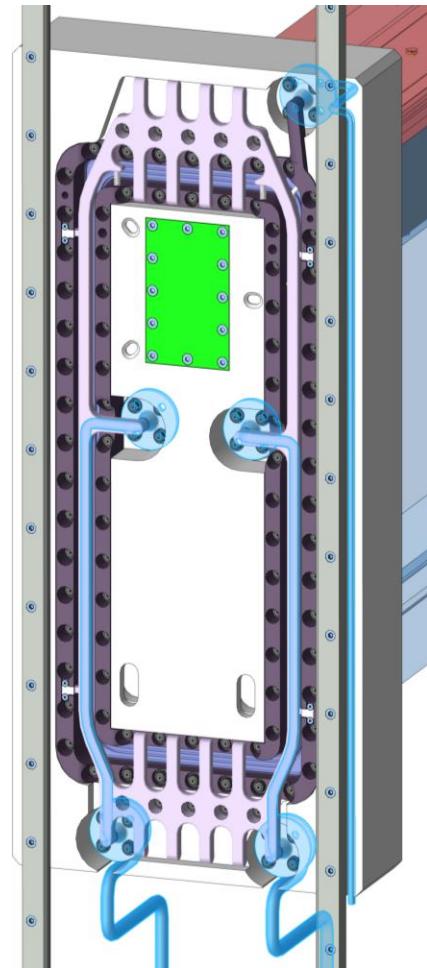

Figure 10 Cooling connection lines (highlighted blue) integrated in the spider. He leak testing line (top, right) highlighted, too.

2.7. Helium leak testing

The sealing assembly must be leak tested after mounting. The leak-tightness of the lip seal welds can be tested earlier, in the factory. The in-situ leak test cannot be hands-on, as the area is radiating. Two conceptual solutions are available to enable leak testing; one with a permanently integrated helium line, and distribution to the double-sealing flange.

The other option is to clear the area to enable remotely operated tooling to approach the flange to connect a helium line.

2.7.1. Permanently integrated option

Therefore, it is integrated in the seal flange and tubing towards the port. For this, a conventional flanged connector is integrated in the top-right corner of the outermost flange (Figure 11, right). As with the cooling line flanges, the flange connects to the vessel flange hosted on a line, which has a $\pm 2\text{mm}$ flexibility designed into it, see Figure 12.

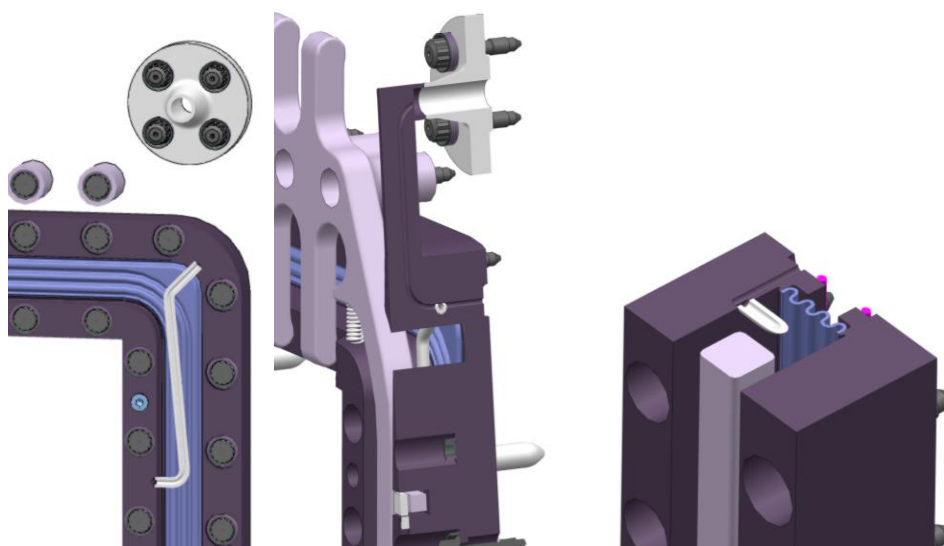

Figure 11 Left: cross-section showing flanged connector and distribution to the outer seal ambient side. Right: planar cross-section showing helium feed for leak detection from outer to inner flange (line should have more flexibility in the future).

The line can be supplied with helium, and the internal channels make sure the outer and inner seals can thus be flushed with helium on the ambient side. From within the vacuum vessel it is then easy to determine any ingress of helium indicating a leak.

2.7.2. Remotely operated tooling providing helium

After moving shutter(s) up to the cul-the-sac, or moving them down and getting them off of the vertical handling rails (by cask and/or cart), a carriage can be installed on the vertical rail which can travel upwards and engage helium to the flange, either by a temporary line, or by a small cylinder. This procedure has a little overhead when (re)installing a seal compared to the permanent option, but the handling overhead

(clearing and storing the other shutters) is much larger when using this method to check leak-tightness of one seal.

The cart could look much like the polishing robot cart, described in 4.5.3.

2.8. Vessel-side features of the NBseal

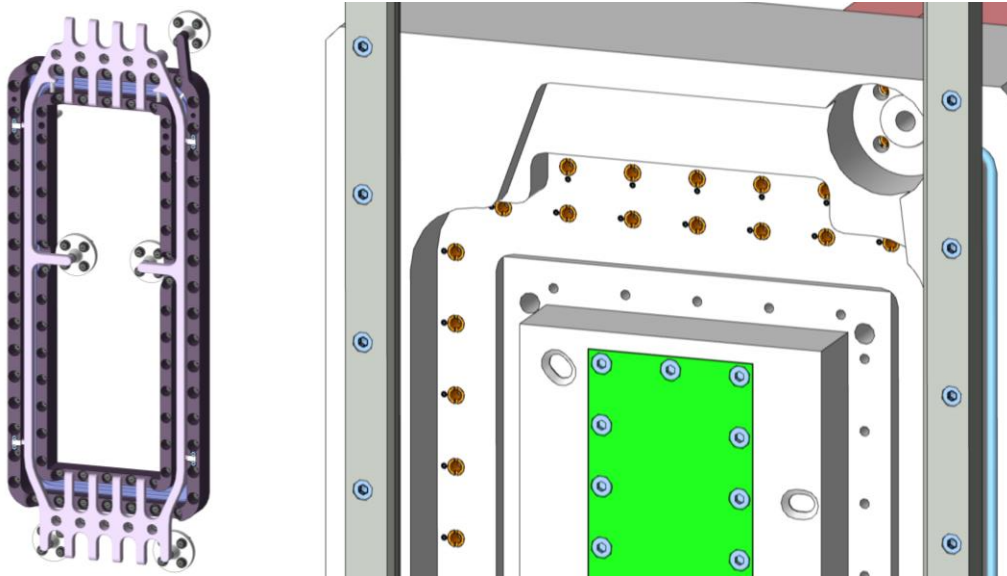

Figure 12 Left: updated seal assembly with an extra helium feed connector on the top-right. Right: Top bit of the vessel docking surface shown, with RH inserts (orange) and their locking pins visible.

As the vessel surface has to be re-used under remote handling conditions, it is mandatory to use RH inserts to be able to refurbish threaded holes. These are present in Figure 12, and complemented by a locking spring pin to keep them in place. Dedicated procedures exist to be able to replace them remotely.

Document Type	Report
Document Number	ESS-0044607
Date	Apr 29, 2016
Revision	3
State	Released
Confidentiality Level	Internal

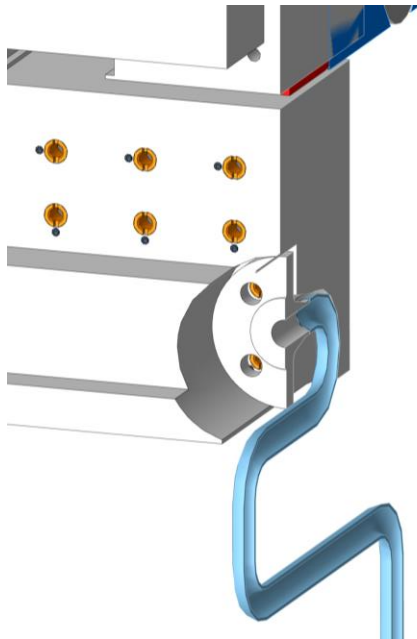

Figure 13 Cross-section of the large helium feed compliant stub. The oversized holes and the RH bolts with aligning nose, will combine to self-align the vessel side flange to wherever the flange on the spider might be.

The Helium feeds to the insert are fed through the compression spider. As the inserts position versus the vessel cannot be driven by this back interface, but rather is through its heavy-duty kinematic mount, the features crossing from vessel over to the insert require to show compliance to a $\pm 2\text{mm}$ position offset. As the compression spider lacks room to integrate this, the studs on the vessel side are mounted on a compliant stud assy (Figure 13), which is specifically designed to be stiff in insertion direction (axial) but flexible sideways.

A smaller version of this compliant stud is integrated on the top-right for the helium feed for leak detection.

The insert port flange plate is now 150mm thick, and has to be welded rigidly and vacuum compatible to the port block. The base plates of the monolith have excerpt allowing for the port flange plates. The back of the plate is closed (except of course for the NBGI port itself). The cooling lines and helium line run to the basement, the exact routing is to be defined by fluids group. The sealing surface on the plate shall be refurbishable by remote tooling.

2.9. Extra shielding



Figure 14 Version of the assembly with orange, permanent, shielding between and above ports. There is a 390mmx494mm wide handling area at all ports. The bit above the ports extends out of the R6000mm

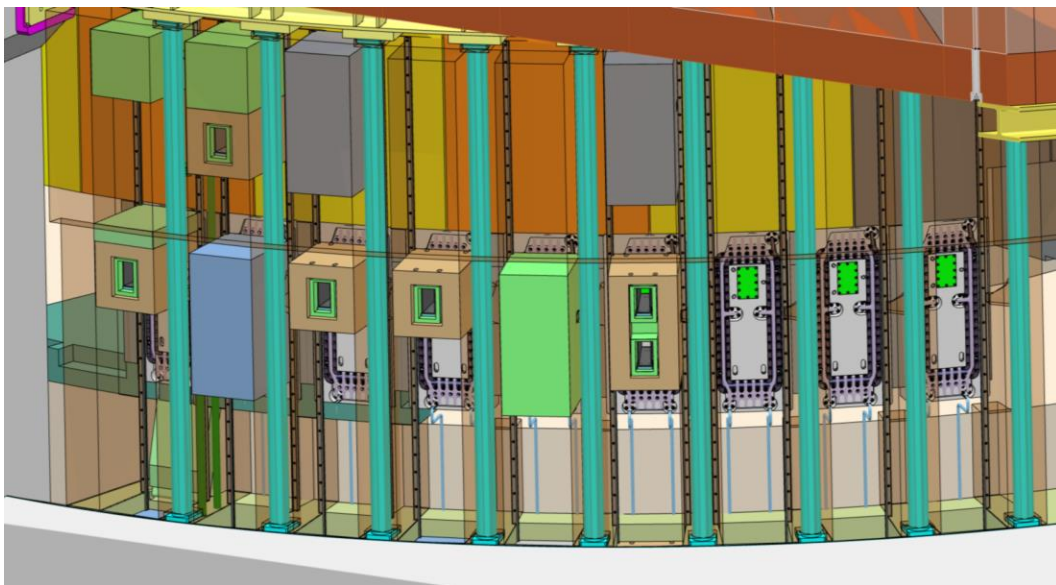

Figure 15 The orange shielding (translucent here) can house shutter(s); the shielding is 'wrapped around' the bunker roof support beams (green-blue). Shutter(s) can be stored in the floor as well.

The area to the top and bottom are shielded as much as possible. The block on the top is con-form to the given shutter form, which depends in turn on the beamline configuration.

To the left and right of the beam ports, shielding is conceptualised as in Figure 14, Figure 15. The shutters are able to freely move up and down between the shielding in the 390mm wide corridor. The geometrical form of these is of course dependent on the beamline design as well. Their function is to help shielding neutron beam-originating

scattering neutron and secondary radiation to other beamlines, and more generally decrease the overall shutdown radiation level in the bunker. Their effectiveness however depends on their own contribution to gamma background radiation during shutdown.

The shielding is to be integrated with the NBEX tool docking and cask docking for seal flange assembly exchange (if this is to be done horizontally), for every port.

2.10. Bunker roof shielding support pillars

These beams had an H-formed cross-section in the previous design iteration. The bunker roof was updated and the loads on the beams considered for buckling of these beams, with the goal of reducing the cross-section as much as possible, to allow more space for other functions. The buckling length has been decreased by moving the lower support upwards. The current cross-section (**Error! Reference source not found.**) with outer 115 mm and $t = 22.5$ mm has a large factor against the buckling load for the worst-case beam-constraint model. If the bunker roof mass would increase more, the cross-section area can simply be increased through increasing the thickness, while it will still be safe for buckling.

The positioning of these support beams has to be altered from a nominal 6° stepping around the target point, to a regular stepping on the R6m circumference, taking into account the four focal points and the offset which they cause at R6m. This is necessary to provide as much space as possible for cask docking. Two steps between pillars between the south and the east block are irregular compared to the rest, as the pattern there changes from the south-focal point alignment to the east focal-point alignment.

Issues to solve are dealing with the required clearance of between building and monolith due to building tolerances and earthquakes.

2.11. RH compatible bolts

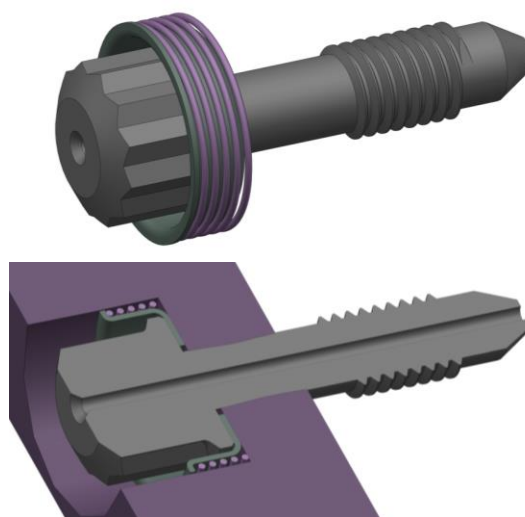
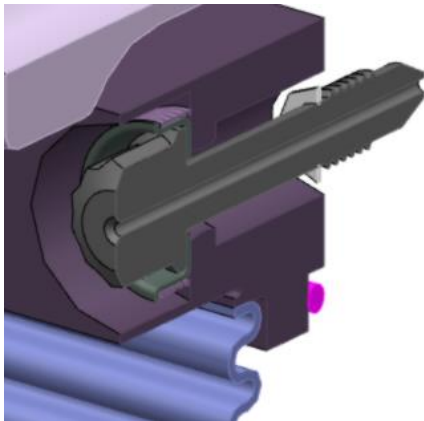

Figure 16 RH compatible bolt. The hole in the purple flange is threaded, thus making the bolt captive. This style is used at the inner seal flange

These bolts, used in the double sealing flange and the compression spider assembly, have to be operated by remote tools. For RH compatibility, they feature a pop-up spring so disengagement of bolts is clearly observable through a camera system or other sensors. The bolts are captive in a replaceable manner; at assembly they are inserted through a threaded hole in their housing. Furthermore the heads are double-hexagon style allowing for better yet compact torque tool engagement. The thread is feathered at the start and end. This gives a deterministic, almost Boolean, feedback on engaging the thread in its counterpart; when off, the bolt will stop when its feathered bit meets the counter-thread (assuming also to be feathered). Testing the bolt for thread engagement by pulling gives two possible results only: either engaged or not. One final point is a small hole through the centre; this is to guide drilling out of the bolt if necessary. The hole can double as a vent-hole when used in blind holes in vacuum, as well.

2.12. Horizontal cask approach



To be able to de-install the NBseal and reinstall a new one, the beamline part close to the port shall be cleared and the NBseal cask entered. The design presented here is conceptual, up to the point where a support frame is not modelled yet, purely to show what functionality is necessary to replace the current NBseal concept. The procedure is worked out in the table below. Be aware that the pictures were made in a less-developed context, some items are distinctly different or even deleted.

Figure 17 Another style of captivity using a snap-on ring, used in the outer sealing flange. This allows bolts to have more radial clearance

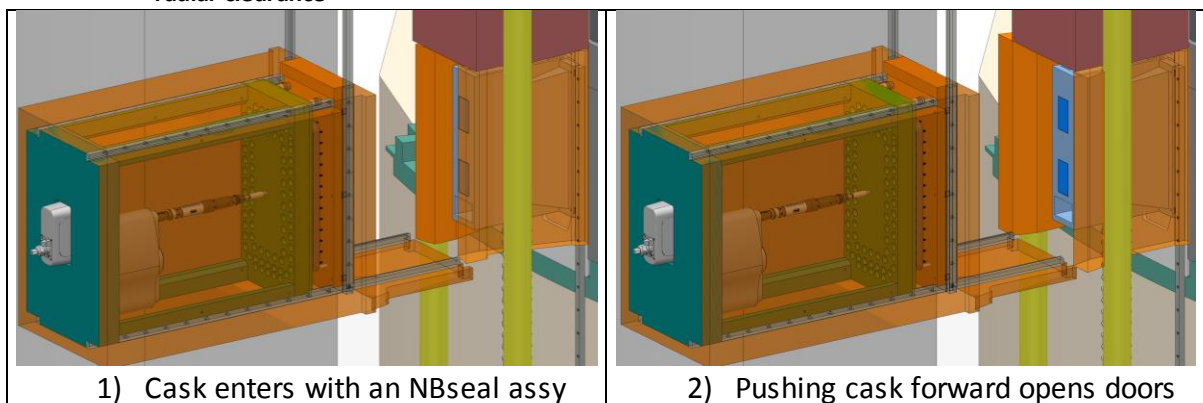

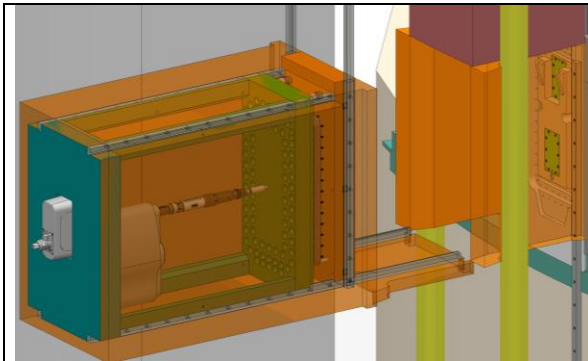

3) Move shutter down

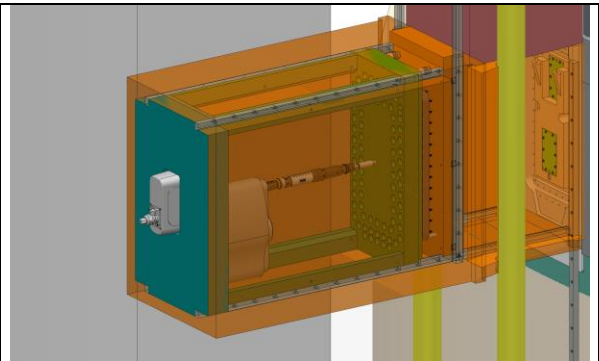

4) Move cask forward to dock

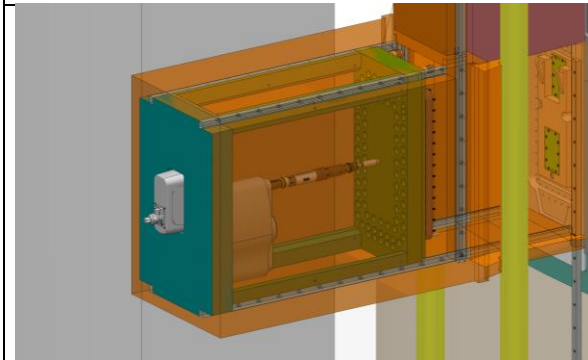

5) Open cask vertical door

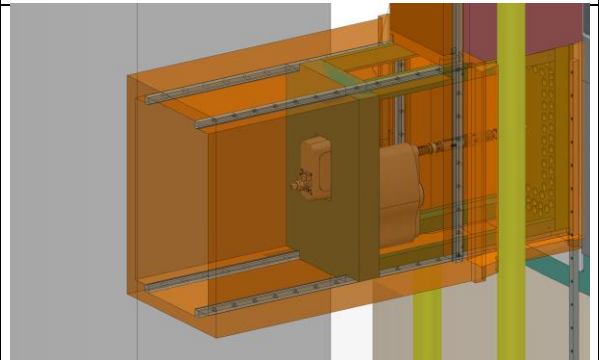

6) Drive carriage forward

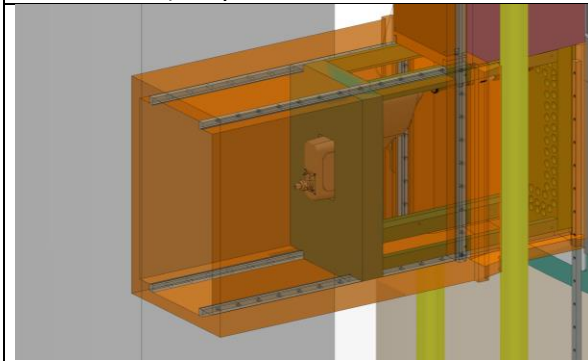

7) Fasten inner seal

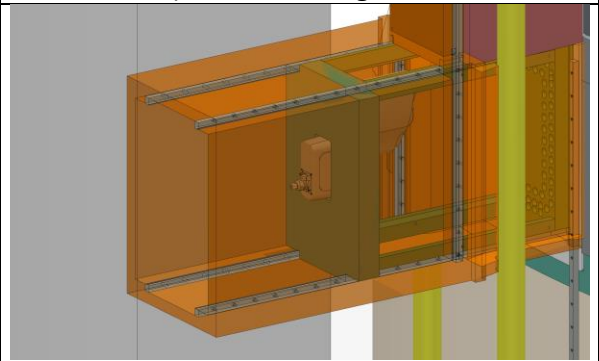

8) Fasten the compression spider

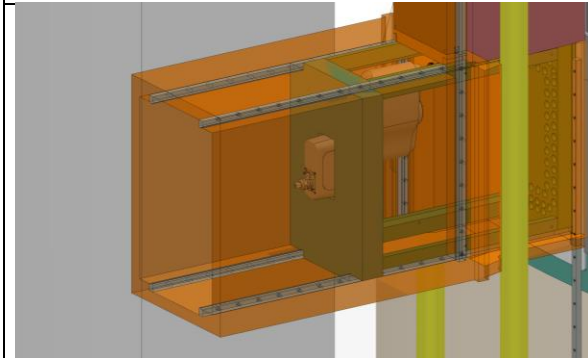

9) Fasten the outer seal

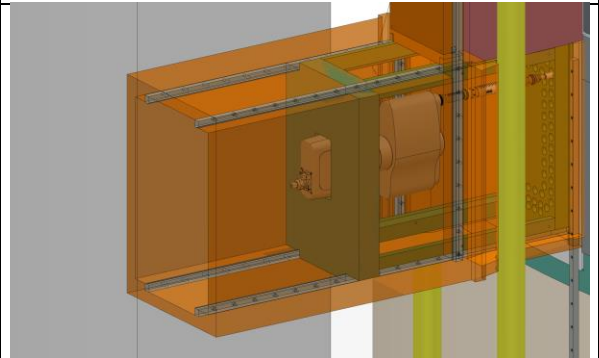

10) Unfasten two bolts to release NBSeal

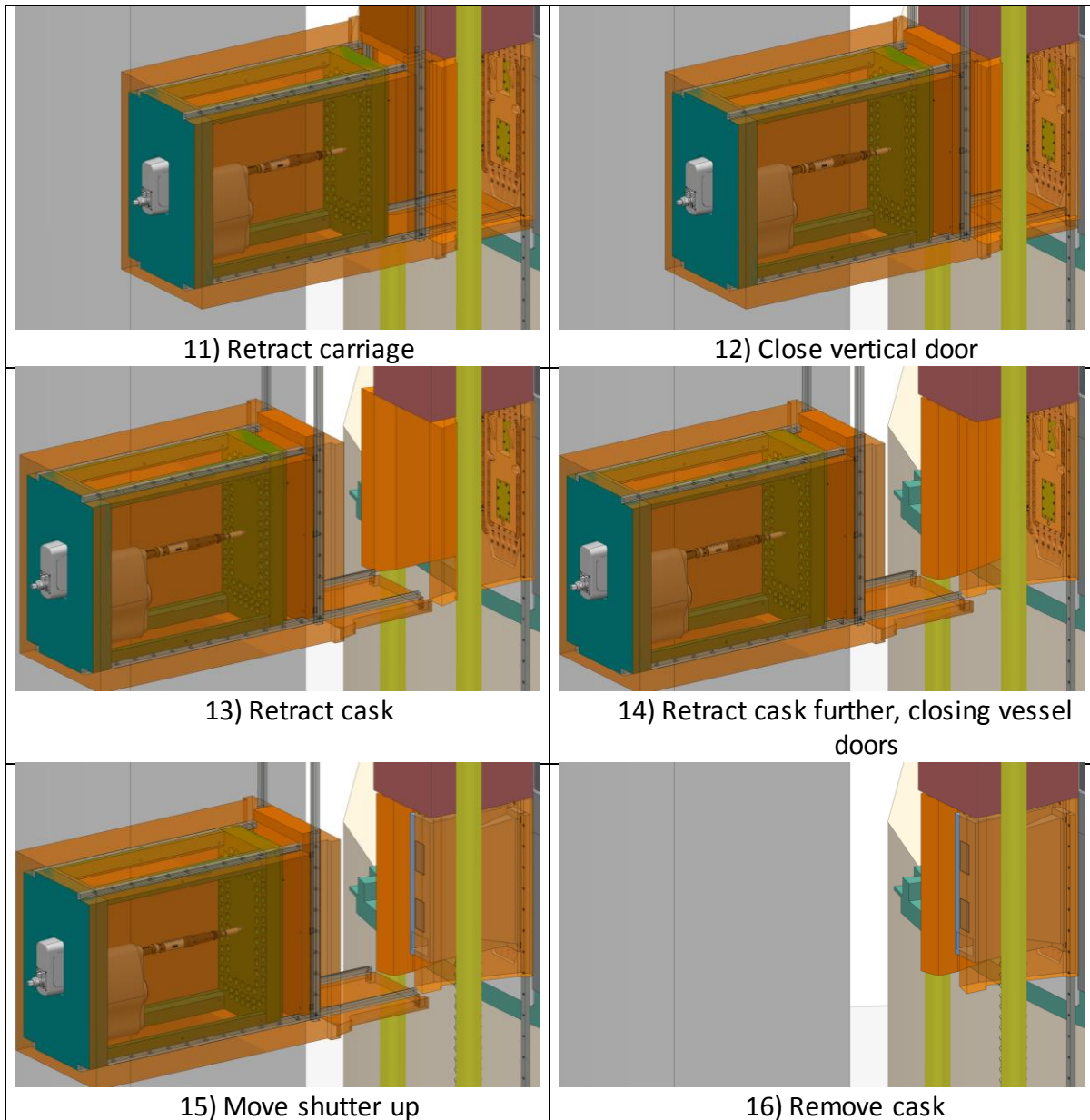

2.13. Remaining issues

- The spider is to be evaluated for stiffness and stress, including fatigue cycling over lifetime.
- The worst-case thermal states of the insert versus vessel shall be overlaid and the spider shall be adapted to the results.
- Bridge shielding shall be detailed depending on radiation situation.
- Bellows in NB seal shall be analysed, fatigue-cycled
- NB-seal, spider, insert and port block flange shall be HW mock-upped

Document Type	Report
Document Number	ESS-0044607
Date	Apr 29, 2016
Revision	3
State	Released
Confidentiality Level	Internal

3. VERTICAL HANDLING APPROACH

3.1. Introduction

This handling approach considers that all handling in the R5.5 to R6m area is to be performed from the basement, except for the NBGI itself. The seal should be replaceable from down under as well. Furthermore, as much shielding as possible shall be added. A rigid chain-actuator shall be used to actuate vertical motion.

The Bridge Beam Guide section shall not be a separate module, but rather be integrated in a cradle, which serves to shield the environment against the radiating BBG section, and as coarse alignment for the BBG. The BBG is supposed to float in the cradle, and align itself to the kinematic mount for it on the back of the insert. The nature of motion and compactness of features require that the kinematic concept be changed so the mating (and holding force) is generated externally from the cradle and gravity cannot be used as previously.

Finally, it has been defined that also a shutter shall be used to block neutron radiation during operation into the instrument line. This creates a host of items that have to move up and down on the common track, with distinctly different requirements. The moving items:

01. BBG: Bridge Beam Guide. Light structure, requires kinematic mount, radiating. Sits in a cradle structure, the:
02. BBGH: Bridge Beam Guide Housing. Heavy structure, mildly radiating. No special mount other than fail-safe. Personnel approachable, hopefully.
03. NBS: Neutron Beam Shutter: Heavy structure, no special mount, radiates heavily. Assumed that a fully enclosed cask/envelope of some 10cm thick material is necessary to allow personnel access near to it.
04. GBS: Gamma Beam shutter (what is commonly called a 'Light Shutter' in spallation): Heavy structure, no special mount, no radiation
05. NBseal: light complicated structure, radiating medium. Needs cask with bolrunner-robotic system for (dis)mounting.
06. Fall hatch: a hatch which opens by rotating upwards towards the monolith foundation. It can serve to protect the GBS from neutron irradiation.
07. Floor Filler block; heavy block, no special mount, no radiation. Used to fill the target level floor

The permanent items:

- FB: Floor block; Heavy structure. Is a target-level floor extension up to the monolith foundation
- PSS: Permanent Side Shield: structure to the left/right of the port, shielding port versus port as much as possible. Thinner at the 5.3deg offsets.
- OS: Overhead shield block; can be customized to contain the NBS during shutdown. If no NBS is used, can contain the GBS. In both cases it is best to try to

Document Type	Report
Document Number	ESS-0044607
Date	Apr 29, 2016
Revision	3
State	Released
Confidentiality Level	Internal

make this a closed-off volume: in the former case to shield the bunker from NBS radiation, in the latter case to protect the GBS against activation during operation. I am suggesting to have a remotely operated locking mechanism (from down below) and a horizontal shielded sliding door.

The usage scenarios:

- BBGH: operational mounted. When beamline is closed, could be moved up into the dead end, or down into the floor, or removed completely
- NBS: to close a beamline during operation this is mounted. When it is not performing its function, move it as BBGH: could be moved up, down or removed completely. Possibly make the overhead block a store for it. Some beamlines will not need/want this, then the handling is simpler as first proposed
- GBS: for a closed beamline during shutdown this is mounted. If it is not performing its function, it should be removed from target level completely if possible. It is probably acceptable though, to only move it into the floor or upwards.

3.2. Configurations

The configuration of bridge beam guide, shutters, sizing and internal layout of these can be tailored per port. The configuration in Figure 2 is only an example. For a two-beamline port the shutter blocks will be larger as pictured. Taking into account the restrained space above the port, this will allow only one shutter or BBG to be moved upwards. So either during ESS operation this action can be used for neutron-beam-blocking, or it can be used for gamma-beam-blocking during shutdown.

However, most ports will have only one beamline. This allows several extra options for shutters; one big shutter containing both a neutron blocking level, and a gamma blocking level. Furthermore, the BBGH can be a combination of a channel, and a gamma blocking level, whilst the neutron blocking shutter is a separate, half-height shutter. Depending on whether the beamline exits through the lower or through the upper portion of the NBGI flange, options exist to swap around these functions.

The optimal configuration of these might be different for each beamline. Important issues in choosing the configuration are:

- Any NBS will be heavily activated and therefore needs shielded storage during shutdown. Temporary removal of the NBS in a cask is a possibility
- A gamma beam shutter will normally contain tungsten, which activates heavily under neutron irradiation. Therefore, combining these two functions in one component is not preferred.
- Any BBG will activate a bit, it is questionable whether the BBG would have to be removed during maintenance to allow human access. Choppers and further beam guides would activate as well, posing the same problem.

Document Type	Report
Document Number	ESS-0044607
Date	Apr 29, 2016
Revision	3
State	Released
Confidentiality Level	Internal

Further considerations

- Making BBGH larger than strictly necessary improves neutron shielding for neutron channelling along the NBGI – following this through, means a single-channel BBGH might be > full-height of an insert.
- The gamma shielding function is improved when covering the insert-port block slit as well, meaning the GBS is optimal when as large as possible.
- To a certain extent this is true for the NBS as well, but the ‘big win’ of an NBS is directly at the beam-line. Furthermore, if systems would want an NBS, it should be used a fraction of the operational time, so having it full-height is less important then.
- The full height-items eat up a lot of storage space, disallowing storage of both the BBGH and NBS to the top
- Larger shielding items will produce more radioactive waste
- Radiation-free storage of the GBS will inhibit the GBS from becoming activated, reducing radioactive waste.
- The storage to the top (1328 mm above a docked item, of which 100mm is allotted to shielding, an additional 100mm can be allotted to an horizontal sliding hatch) can contain:
 - o two single-channel height items (382mm each), optionally with an horizontal sliding hatch
 - o one full-height item (807mm), optionally with an horizontal sliding hatch
 - o one full-height item with one single-channel height item but not an horizontal sliding hatch – or the full-height items’ height decreases thus shield function, too.
- The storage ‘in’ the bunker floor is 1250mm. The usage here is more flexible as it is not a cul-de-sac, rather anything which would not fit could be taken away in the basement at the cost of logistic overhead, which gets larger if a cask needs to be employed.

Target system states which are common to all instruments (not all have be relevant for a beamline):

- 1) Operation – NB channel open – BBGH mounted
- 2) Operation – NB channel closed by NBS
- 3) Shutdown – NB channel open – BBGH not mounted
- 4) Shutdown – NB channel closed by GBS
- 5) Shutdown – NBGI removed, port open
- 6) Shutdown – NBGI removed, port closed by GBS or other block

Open-channel configurations other than operational should be avoided.

3.3. Use cases and resulting configurations

Options from the previous sections are evaluated producing realistic configurations

Document Type	Report
Document Number	ESS-0044607
Date	Apr 29, 2016
Revision	3
State	Released
Confidentiality Level	Internal

3.3.1. Upper-channel instrument

1. If NBS is wished, put single-channel-height NBS at highest location then BBGH, then single or double-channel-height GBS. To reach state 4) the BBGH can be pushed upwards with the GBS. For state 6), the GBS can be used if it is made large enough. Otherwise for NBGI replacement, all three items would have to be removed downwards, then off the rails, and a floor block or alike must be pushed upwards to block the port
2. Alternatively the NBS can be full-height, but either the horizontal sliding hatch is then not an option, or the BBGH must be brought down and removed prior to bringing the GBS reaching state 4).
3. If no NBS is wished, the GBS can be full-height with its parking location at the highest location. Then the GBS might be usable for state 6) as well – possibly improving the performance in that state by enlarging it a bit.
4. Without NBS, the BBGH can be the topmost in the line as well, with GBS stored in floor. The BBGH is then parked upwards when transiting to state 4)
5. For systems without BBGH (currently ESTIA), only a GBS is required which can be parked upwards. If an NBS is required, the situation is similar to option 1.

Concluding, option 1 – using a full-height GBS which doubles as port-blocker in state 6), seems most efficient. During state 2), the BBGH would then sit directly below the NBS, or on the floor of the bunker. The BBGH and NBS could be integrated into one block, if the gamma load of the partially-exposed NBS during state 1) in the bunker is not a problem. This might be suboptimal from waste perspective, but the impact is small.

3.3.2. Lower-channel instrument

The difference with upper-channel is that the cul-the-sac portion of the rails is some 280mm longer (depending on the exact design, of course). This has no specific benefits. Integrating the BBGH and NBS would expose the bunker fully to NBS gammas during state 1).

3.3.3. Mid-position, larger cross-section channel

E.g. ESTIA looks like it will have a somewhat larger beam in the midst of the NBGI flange – the NBS+GBS will be a bit higher. The upper-channel situation (section 3.3.1, excl. subsituation 2) applies probably.

3.3.4. Bi-channel instrument

The only bi-channel instrument known at this point is Heimdall. For bi-channel it is not feasible to have NBS+GBS on top of the BBGH.

1. If an NBS is required, it has to be in the top position to render it usable during operation. Achieving state 4) would then require removing the BBGH into the basement and taken away, before the GBS can be put on the rails to move upwards and block an open channel. The BBGH will need a cask, so quite some logistic overhead.

Document Type	Report
Document Number	ESS-0044607
Date	Apr 29, 2016
Revision	3
State	Released
Confidentiality Level	Internal

- Without NBS, the GBS is housed in the top position. BBGH can be moved down in the floor during state 4). The floor thickness is not optimal during operation, as there is a large void where the BBGH would be stored during shutdown, or an extra floor block should be added.

Concluding, for a bi-channel instrument, not having an NBS is advantageous.

3.4. Rigid chain actuator

Rigid chain type actuators (Figure 6, refer also to section 2.3) provide a compact way and are compatible with the expected motion lengths and payloads. The chain can bend only one way, tempting to store the cassette of the actuator in monolith radial direction. However, as the lower concrete shield cylinder steps back a bit from target level (which is R5500mm) to R5275 directly below the port blocks, this provides a nice area suited to store two full lengths of chain actuators as sketched in Figure 20. Space is tight, though, and the storage of the chain protrudes in the floor filler volume, decreasing shielding capacity there.

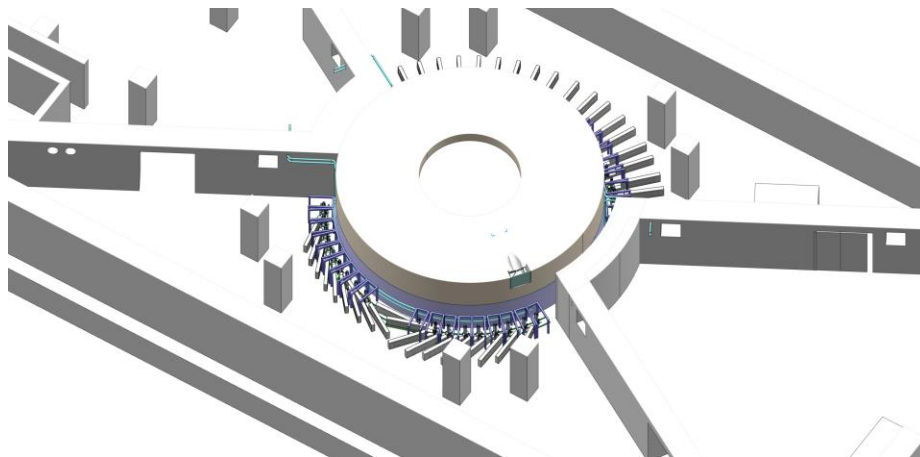

Figure 18 Example positioning of actuators in the basement. Radial in the East and South sectors – which is incompatible with casks – tangential and at various angles in the North and West sectors. Not all actuator locations can be occupied by an actuator at the same time.

Alternatively, the actuator can be oriented between radial and tangential, depending on the configuration in the basement, see Figure 18 for examples.

Document Type	Report
Document Number	ESS-0044607
Date	Apr 29, 2016
Revision	3
State	Released
Confidentiality Level	Internal

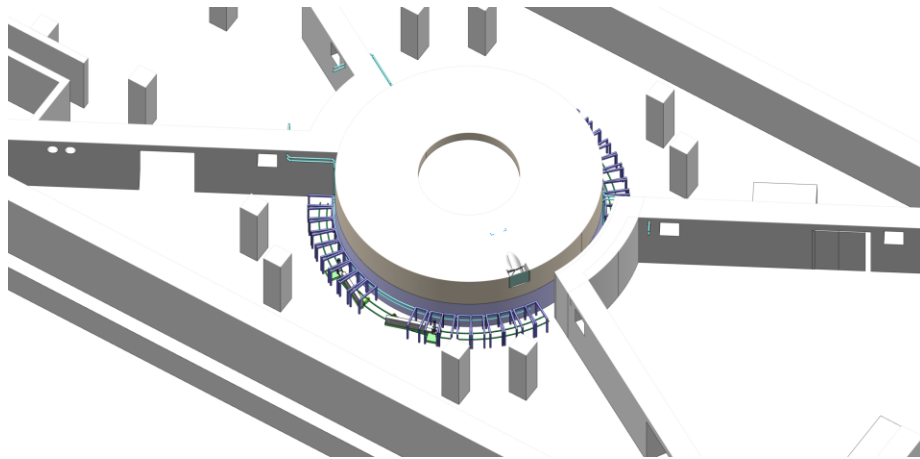

Figure 19 Nort and West sectors in basement services by two actuators (position tangent to circle) on circular rails

Both options allow having only a few actuators servicing all ports at one side of the proton beam, when these are mounted on a rail circularly following the monolith base (Figure 19). For the systems having an NBS (thus using it during operation), it is advised to have actuators permanently at the relevant locations, as using the rail system would incur having human supervision, which is not possible during beam operation.

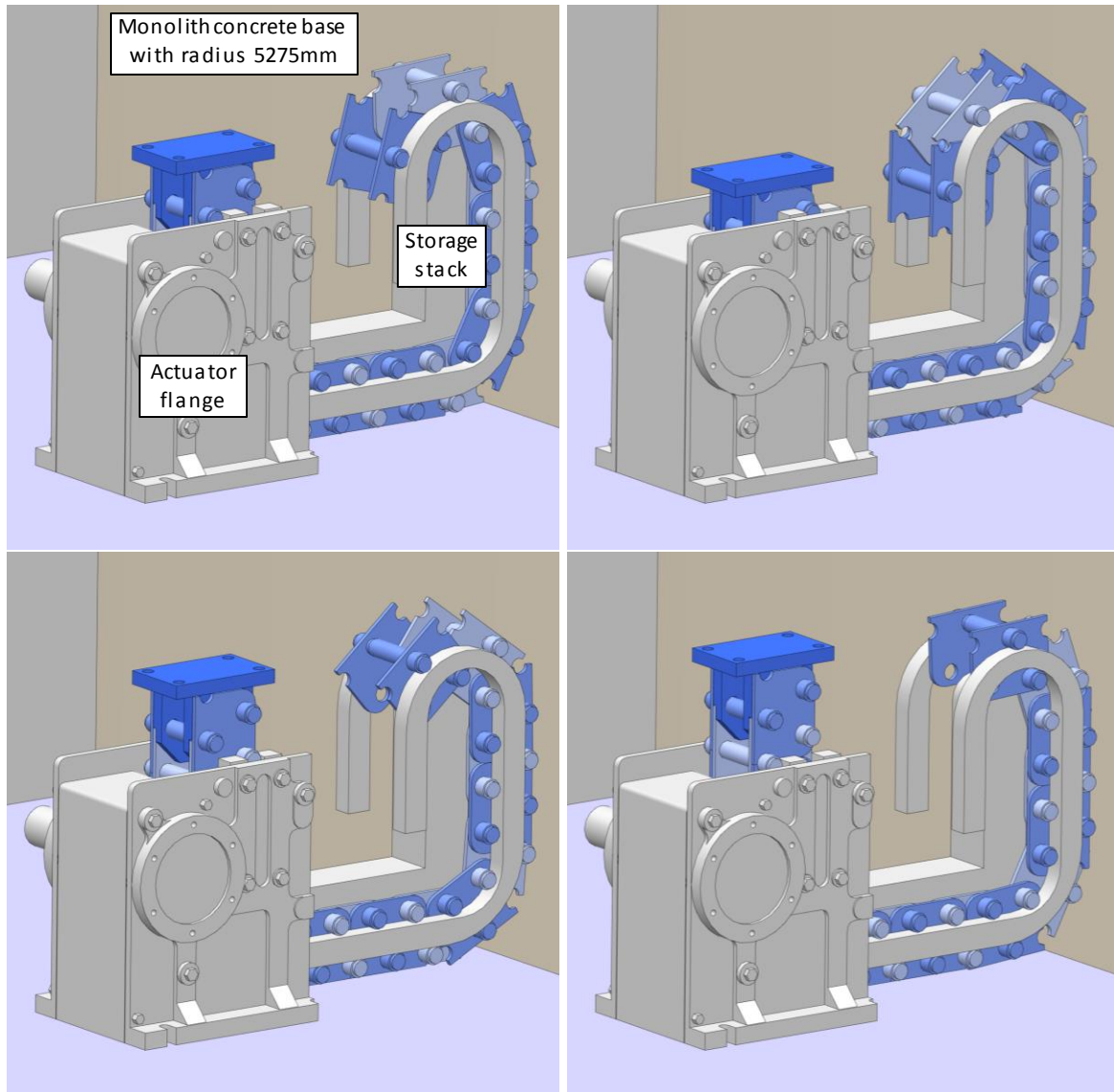

Figure 20 Rigid chain actuator with sketched storage in R5275 to R5500 area. The storage is to be extended vertically as much as necessary.

3.5. Further motion concept

Using the rigid chain as actuator to move the ‘train’ of components up and down the guide rails, the blocks need also a few distinct locations where they can be locked, to ease the handling of the rest of the train and locate the blocks.

1. Within the overhead filler block a locking feature, controllable from basement level, shall be added
2. On target and storage levels, a locking feature to block the BBGH or other component, is added and presented in 3.6
3. On target level, a special feature shall be added that is able to push the BBG forward in the BBGH, until it meets the kinematic mount on the insert. This

Document Type	Report
Document Number	ESS-0044607
Date	Apr 29, 2016
Revision	3
State	Released
Confidentiality Level	Internal

system is presented in section 3.7. An example kinematic mount is presented in section 2.1.

4. Within the target level floor, the floor filler block should be lockable.
5. The overhead sliding hatch allows closing the shielding of the overhead storage volume completely. The hatch shall be closed to allow NBEX tool to dock. It is not expected to interfere with other operations though
6. The fall hatch is a useful addition to shield the GBS from radiation during operation and to shield operations in the basement from gamma radiation. It folds away in the recessed monolith base.

The (mechanical) linkage system of these features shall run through the features at the side, e.g. the side shield block, the sides of the floor block etc. In this way the actuators can be down in the basement and the rest of the system can be passive (i.e., not have actuators/electronics in radiated areas).

3.6. Block locking system

This system is housed either on the left or the right side of the port, as most convenient. For the 5.3deg separated ports, however, it is housed in the side to the 6.7deg separated port.

It consists of a locking block, currently at four discrete levels around target level, and 4 additional at the storage space above [1]. In the target level floor, this system is not needed as blocks can rest on the floor filler block, which is to have its own locking system.

Furthermore, an engaging rod can be vertically inserted to the desired locking level, and then rotated left or right to lock or unlock, see Figure 21. There is no visual feedback, so there has to be monitoring of the rod insertion length, and the rotation angles used, to derive whether a contact felt is the intended result or not. The locking block will be friction-locked by the dead weight of the shutter block resting on it, so in that case rotation is impossible. Leaving the engaging rod in place during operation, and locking the rod from the basement, can result in a positive lock on the locking block, as to prevent accidental locking block motion during seismic events.

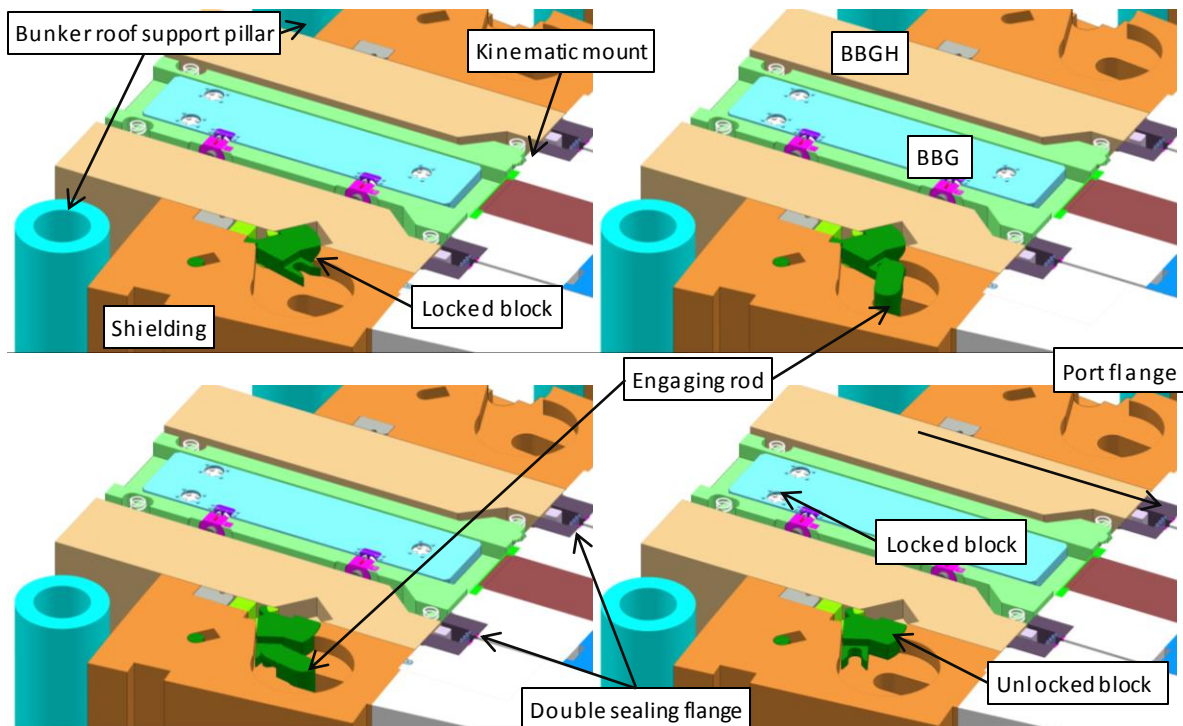

Figure 21 Horizontal cross-section (about target level) showing engaging of the block locking system. Top-left: locked situation (green block), top-right: rod with extension is inserted and rotated till it meets the block, lower-left: rod is further rotated to disengage the block; lower-right: the rod is further rotated and removed. Optionally it can make a full circle to double-check the disengagement.

3.7. BBG engaging system

The BBGH is cradling the BBG, expected to carry neutron guide mirrors. This item needs to be positioned highly accurate to the NBPI, using a (small) kinematic mount. The BBG should then be pushed forward to engage its mount. There should be a moderate pushing force on the mount during operation; in the example design 200N is enough. This is accomplished by a linkage providing three vertical positions where it can deliver this force. The BBGH can pick either position, and should take care the linkage can move the other two stamps, but not touch it there.

The linkage is, as the shutter block locking linkage, housed either on the right or the left of the port, depending on the port configuration, and normally on the same side as the locking linkage.

From the basement the actuation rod can be pushed upward to disengage, and letting it go/slightly pulling it downward, will ensure by dead weight and (to be implemented) bearings that it engages the BBG.

Engaging the guide section of the BBG works through moving a rod downwards, see Figure 22.

Document Type	Report
Document Number	ESS-0044607
Date	Apr 29, 2016
Revision	3
State	Released
Confidentiality Level	Internal

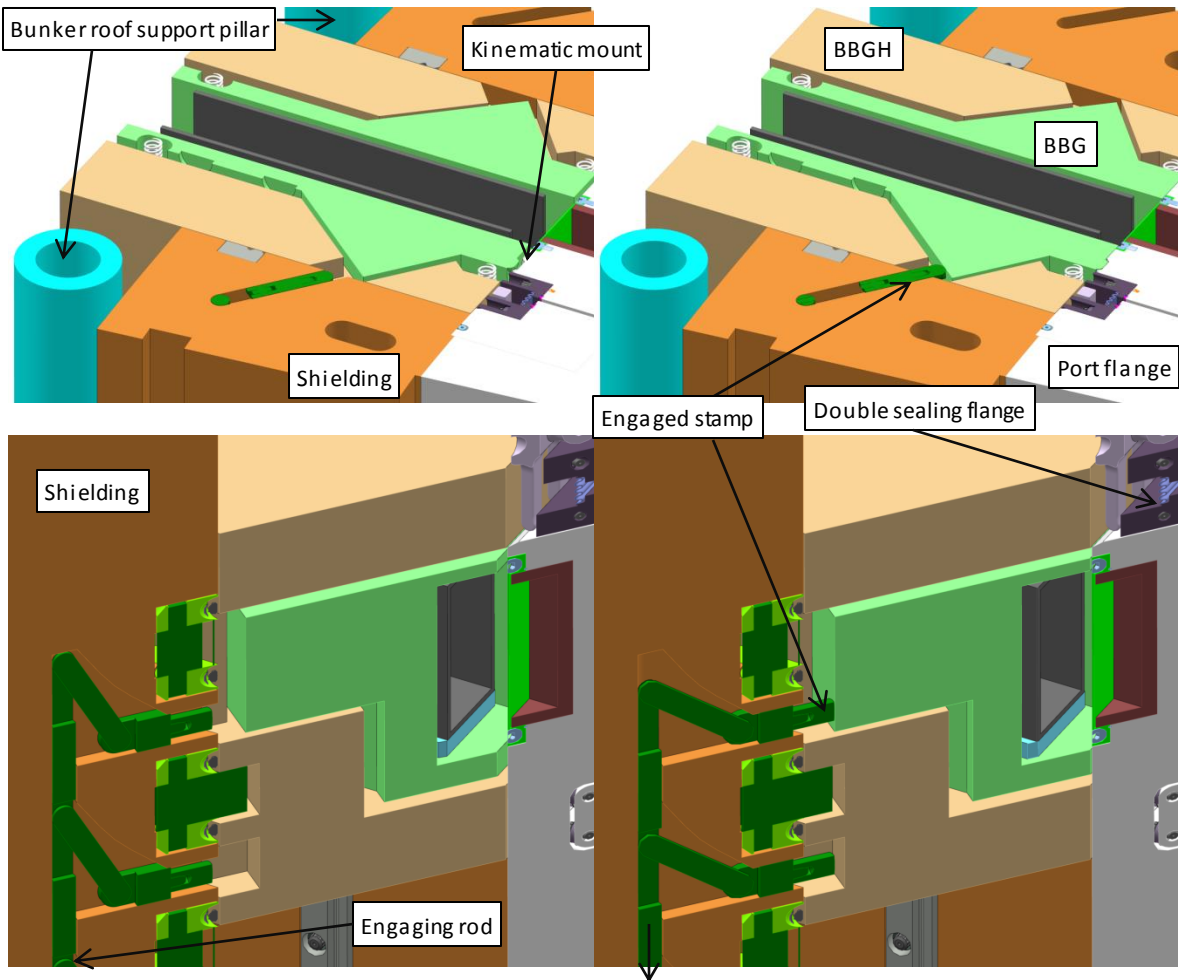
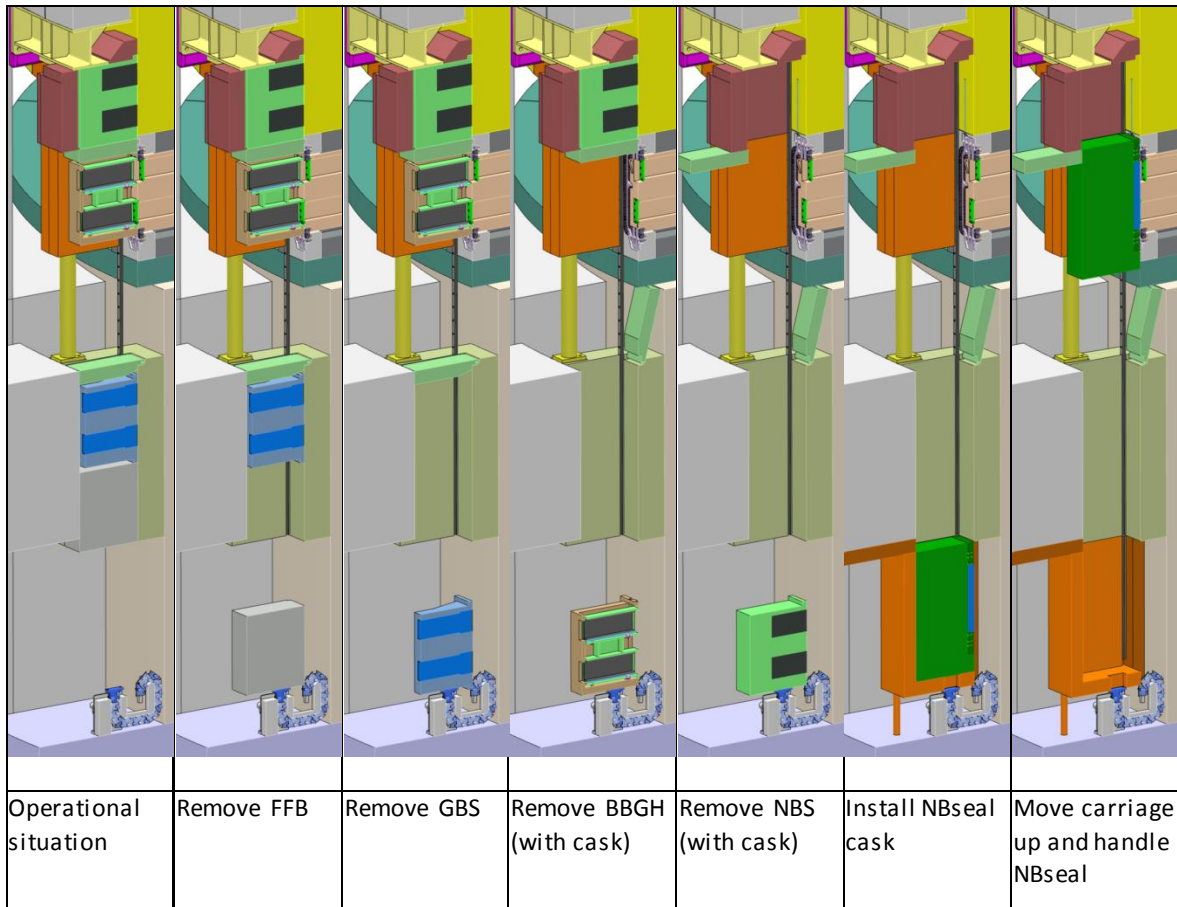

Figure 22 Horizontal cross-section (top pictures), upper moderator level, showing engaging the BBG by stamp linkage. Left: disengaged. Right: engaged. Notice the subtle, 5mm forward motion of the BBG. The lower pictures are a cross-section through the linkage (green)



4. HANDLING SEQUENCES

These are to be captured in PDF/TDFs as per the ESS maintenance framework [2]. Where it reads (un)locking, refer to 3.6 for the common principle. Where (dis)engaging is quoted, refer to section 3.7.

The sequence of figures below illustrates how an operational situation is converted to an NBseal handling situation, for case 1 as described in 3.3.1. After preparations presented in 4.1, installing the NBS in the beamline is shown in 4.2. For the procedure at start of ESS shutdown for this port, first preparations in 4.1 have to be performed, then the steps presented in 4.3 have to be taken, ending in an installed GBS. Thirdly, removing GBS, BBGH and NBS is presented in 4.4. Finally, the NBseal removal and sealing surface refurbishment is pictured in 4.5.

4.1. Preparation

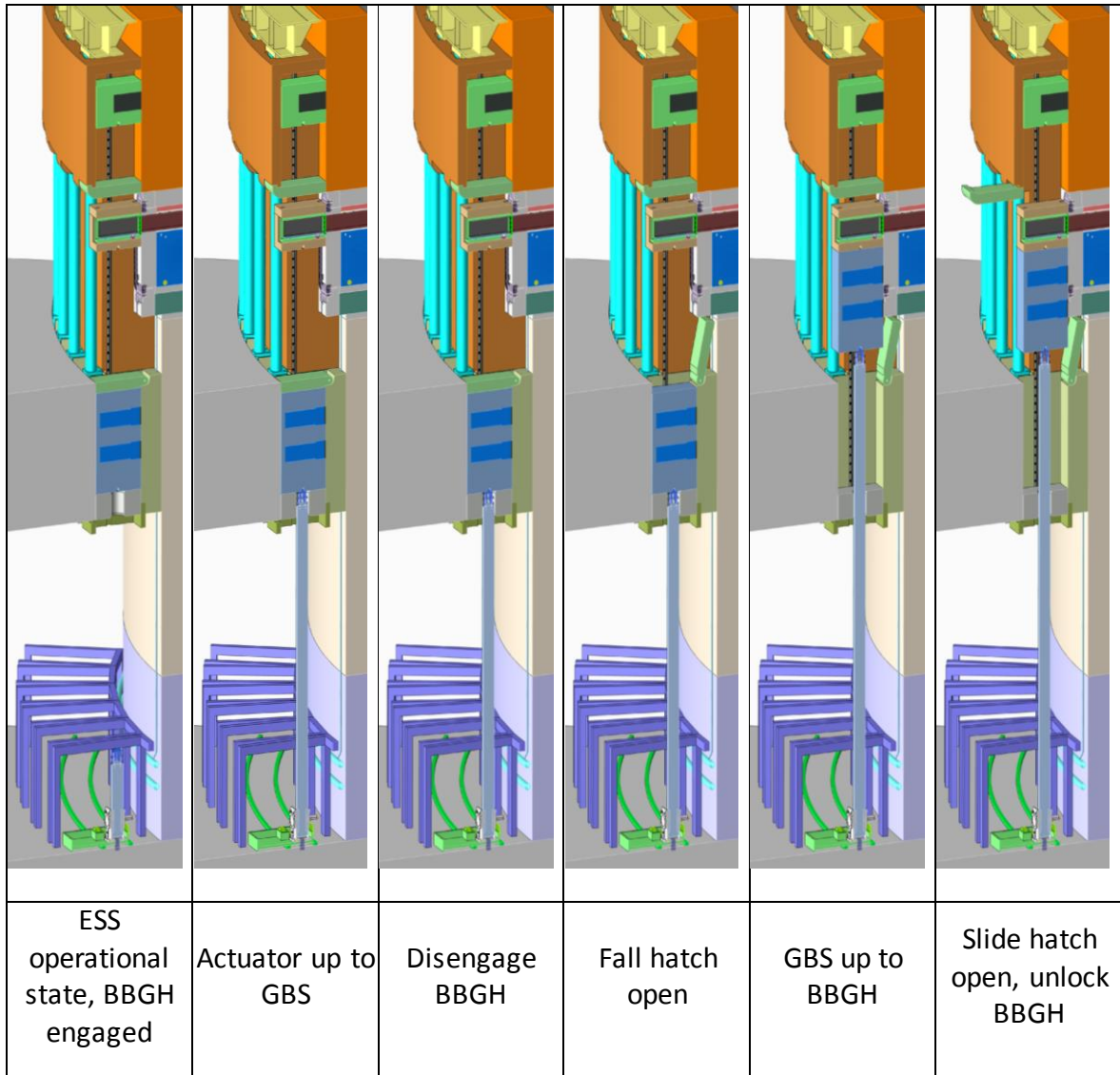

From this point onward, either the NBS can be installed or the GBS can be installed.

4.2. Installation of the NBS

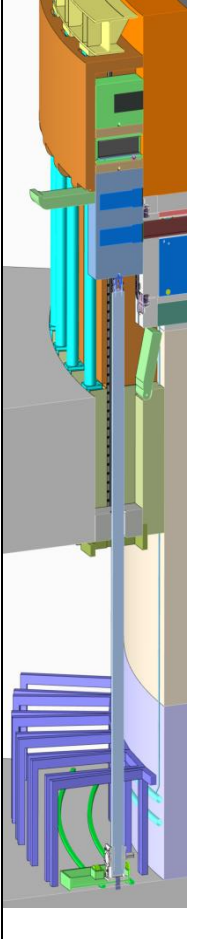
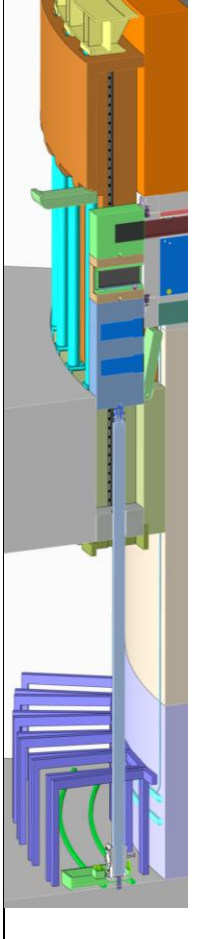
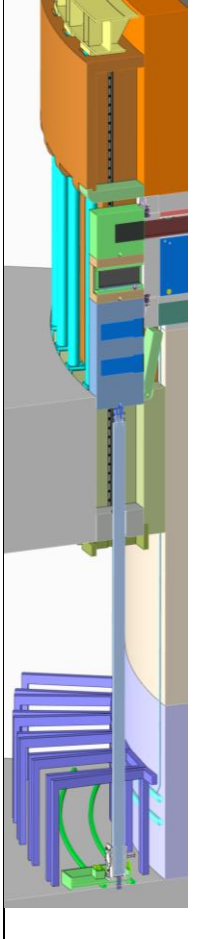
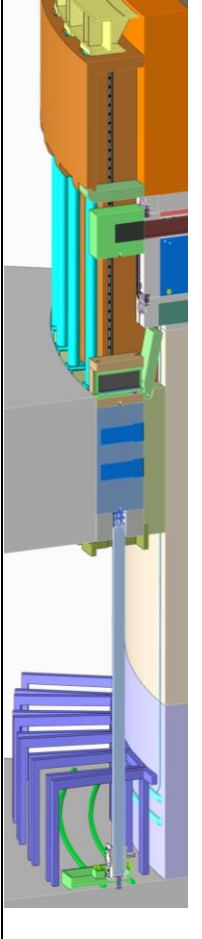
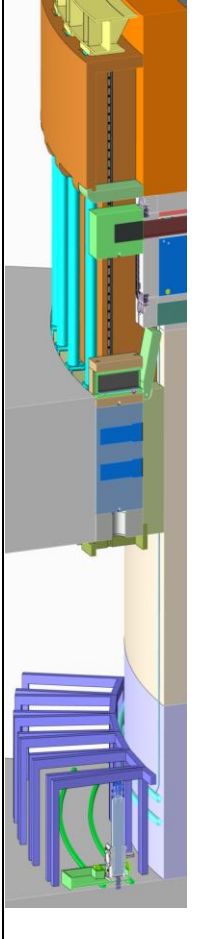
				
<p>GBS+BBGH move upward to pick up NBS. Unlock NBS.</p>	<p>Move train down to NBS operational position</p>	<p>Close slide hatch Lock NBS</p>	<p>Move actuator down, setting GBS+BBGH on floor filler block</p>	<p>Move actuator down. NBS installed</p>

4.3. Installation of the GBS

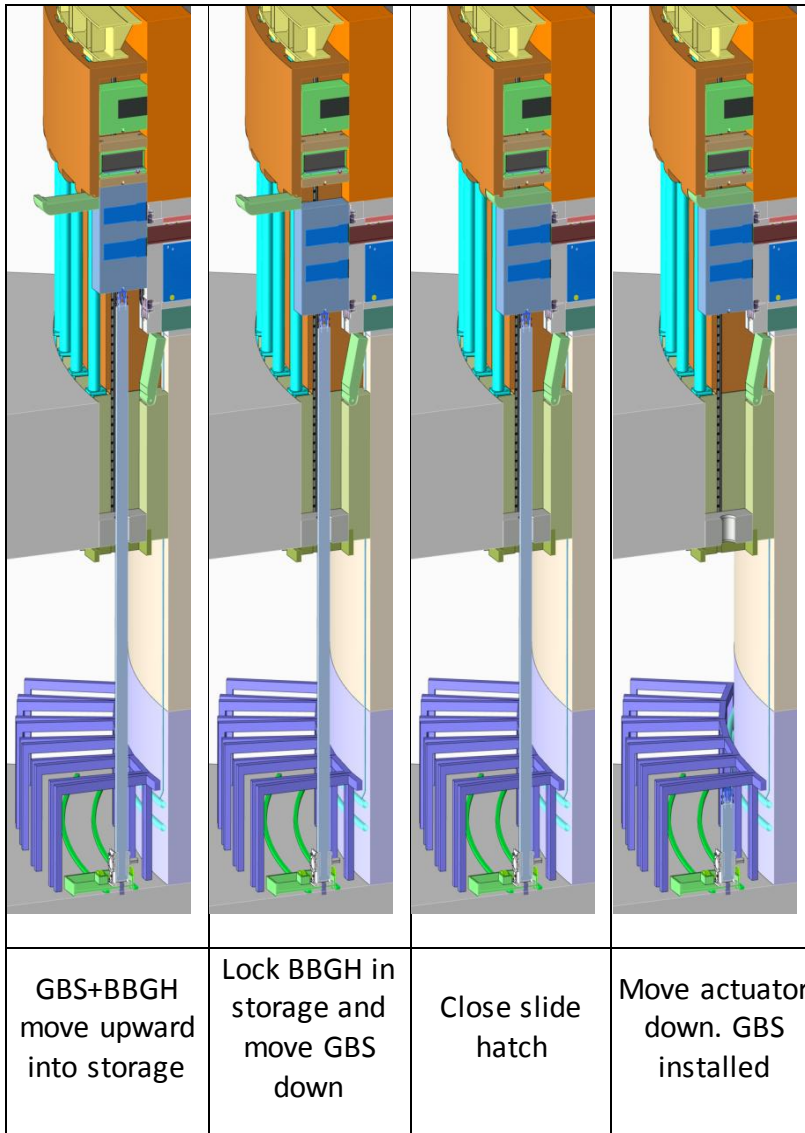

Possibly at the final step the fall hatch can be lowered to diminish background radiation into the basement. One can choose to leave the actuator up, if it is not needed elsewhere.

4.4. Removing shutters

<p>Install shield cart, helper carriage and support platforms. Disengage BBGH.</p>	<p>Reach with helper carriage to pick up floor filler block with GBS</p>	<p>Move down onto the support platforms</p>	<p>Move backwards onto the cart platform</p>

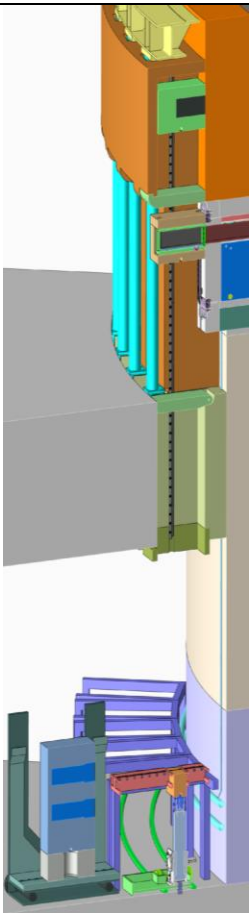
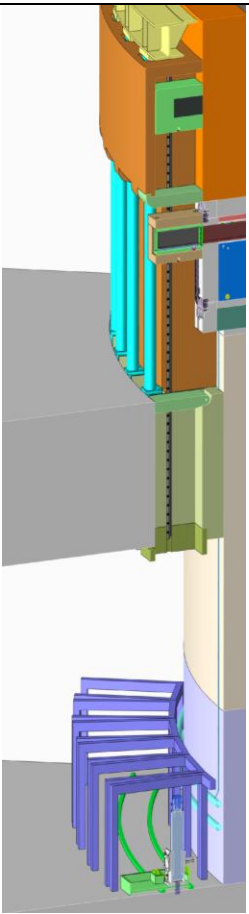
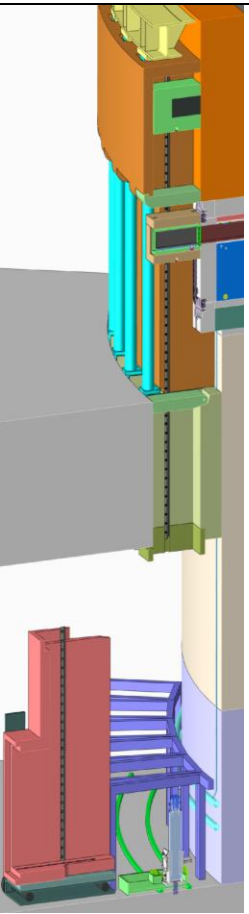
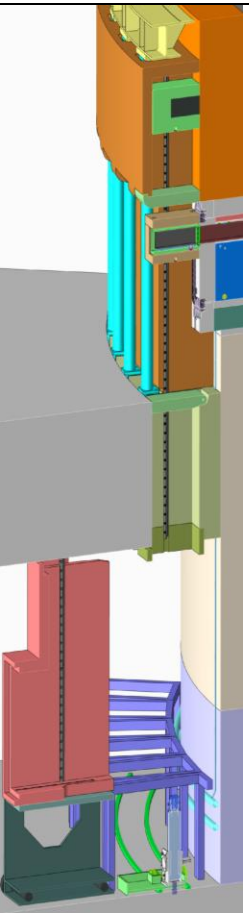
			
<p>Move cart platform down</p>	<p>Remove cart and support platforms</p>	<p>Bring cart with lower shielding</p>	<p>Up the lower shielding</p>

<p>Forward the lower shielding, dock and lock it into place</p>	<p>Remove cart</p>	<p>Dock the Shutter handling cask (empty), open door.</p>	<p>Open fall hatch and reach with actuator to BBGH</p>

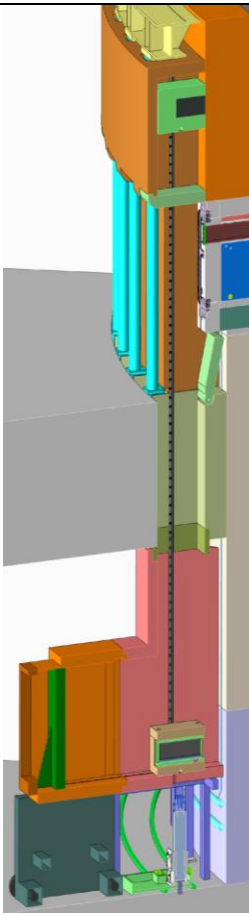
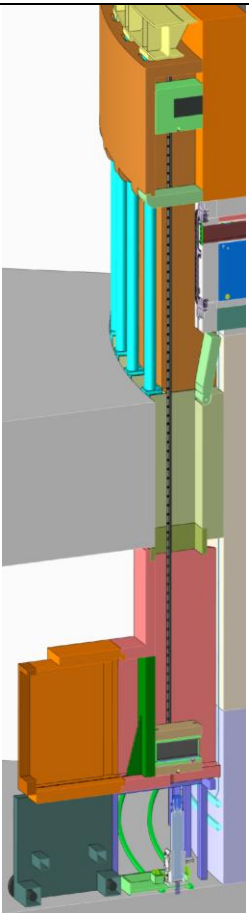
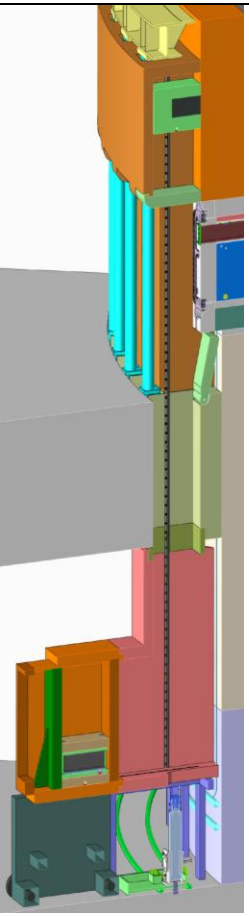
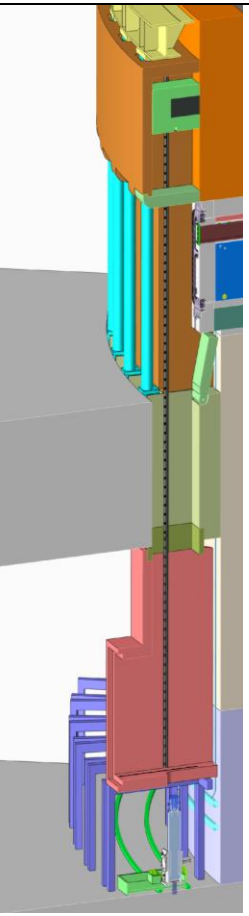
			
<p>Unlock the BBGH, then lower the BBGH onto the lower shielding platform</p>	<p>Bring cask carriage forward and lock onto the BBGH (interface TBD)</p>	<p>Bring BBGH backward and close the cask door</p>	<p>Bring Cask with BBGH to Active cells or storage if it is to be re-used.</p>

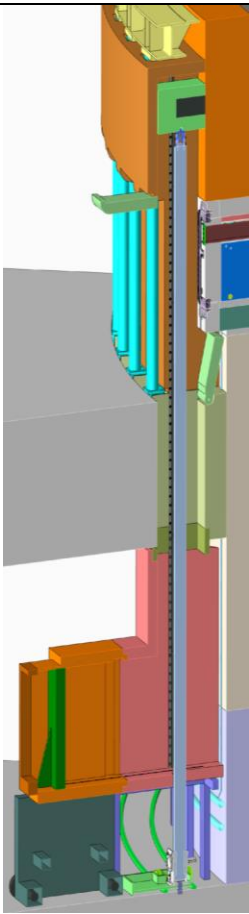
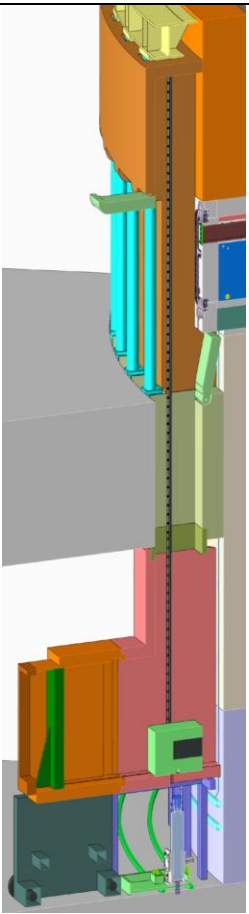
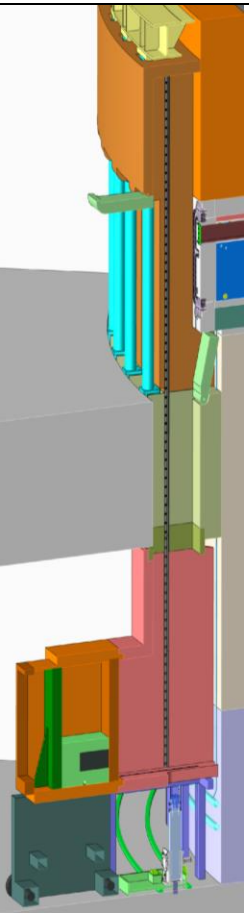
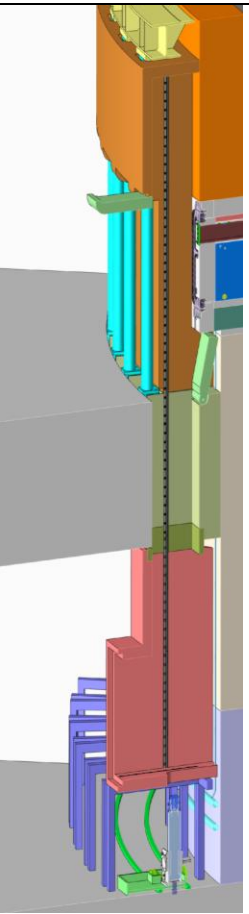
			
<p>Dock the cask, open door, open slide hatch, reach with actuator to NBS</p>	<p>Unlock NBS, bring it down</p>	<p>Bring NBS into cask and close door</p>	<p>Bring NBS to Active cells for disposal, or to storage if it is to be re-used. End situation.</p>

The slide hatch might be closed if needed.

4.5. Removing the flange assembly

Refurbishment of the sealing surfaces on the port block flanges, and on the insert side, would use the same route but with multiple dedicated carriages: one to unbolt all-but-two bolts, one to pick up the flange assembly and unbolt the final two bolts, and one to refurbish the sealing surface on the port flange and/or at the NBPI flange.

4.5.1. Bolting carriage

<p>Bring the shielding cart with the bolting carriage and dock</p>	<p>Lift the carriage</p>	<p>Bring it forward</p>	<p>Using the actuator mount it before the port and unbolt all but two bolts</p>

Bringing the carriage down works in the same manner.

Below the bolting carriage design is presented in more detail

Document Type Report
 Document Number ESS-0044607
 Date Apr 29, 2016
 Revision 3
 State Released
 Confidentiality Level Internal

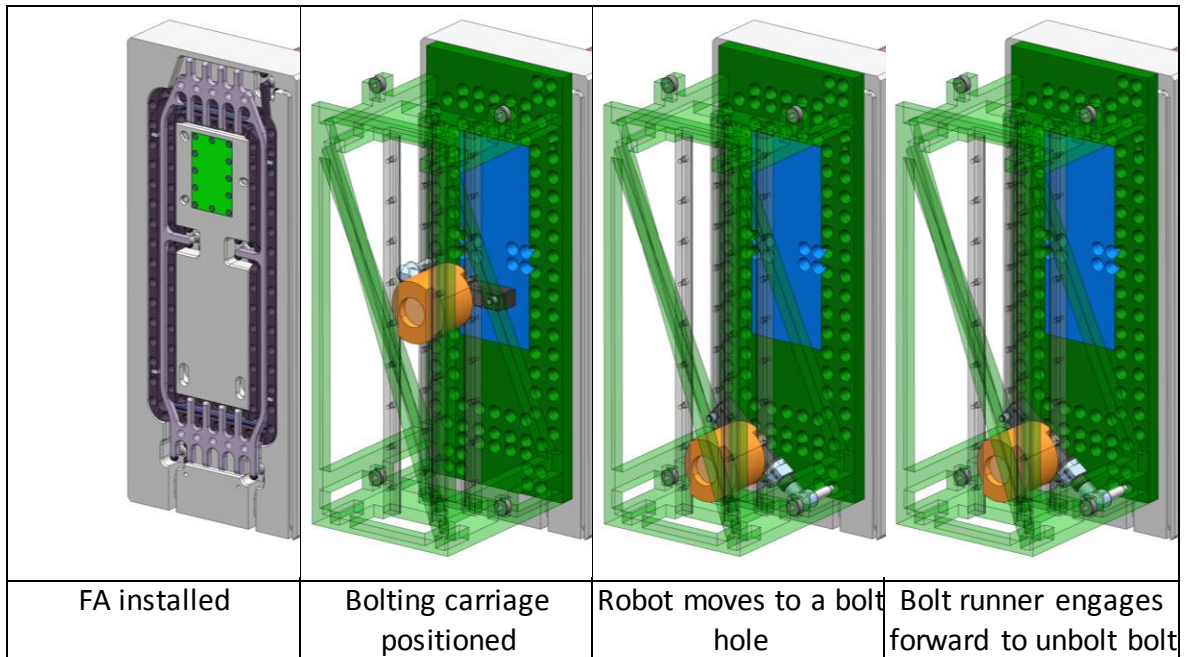

4.5.2. Flange assembly handling carriage

The FA is radiating therefore it shall be moved into a cask.

<p>Bring the shutter handling cask with the FA handling carriage contained in it and dock</p>	<p>Open cask door and move it forward, release the cask carriage grapple onto the vertical carriage</p>	<p>Move the carriage upward in front of the port</p>	<p>Actuate the cylinders on the carriage to dock with the FA, engage the two locking bolts</p>

<p>Unbolt the two remaining flange bolts and retract the cylinders taking the FA with it</p>	<p>Move it down and grapple the carriage by the cask carriage</p>	<p>Move it into the cask and close the door</p>	<p>Bring the used FA to the Active cells.</p>

Below the handling carriage design is presented in more detail

Document Type Report
 Document Number ESS-0044607
 Date Apr 29, 2016
 Revision 3
 State Released
 Confidentiality Level Internal

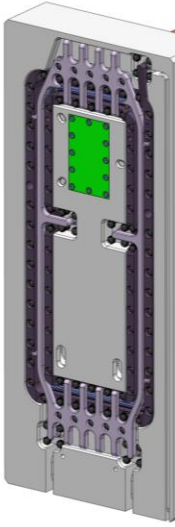
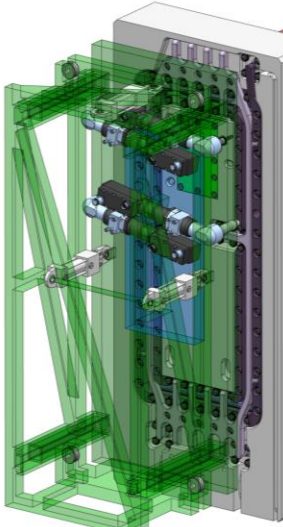
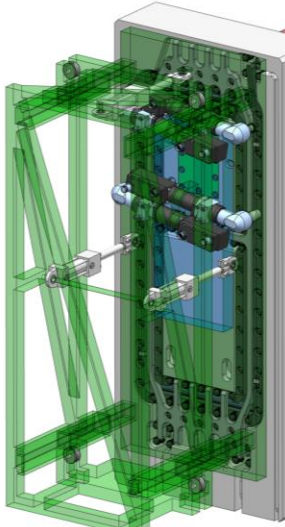
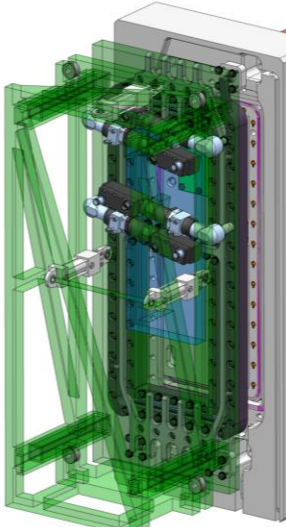
			
<p>All bolt but two unbolted.</p>	<p>Bolting carriage positioned</p>	<p>Cylinders move forward, engage and last two bolts unbolted</p>	<p>Cylinders move backward to retract FA from vessel.</p>

4.5.3. Sealing surface polishing and inspection carriage

<p>Bring the shielding cart with the bolting carriage and dock</p>	<p>Lift the carriage. Bring it forward</p>	<p>Using the actuator mount it before the port</p>	<p>Engage the polishing and/or inspection action</p>

See below for more detail on the polishing carriage design.

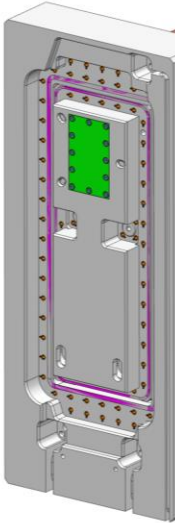
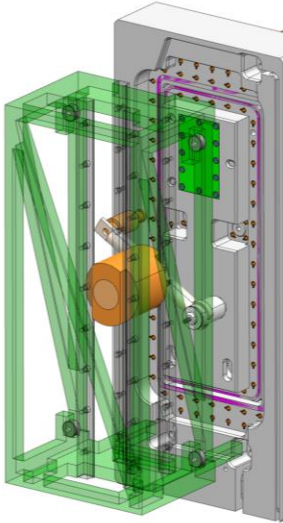
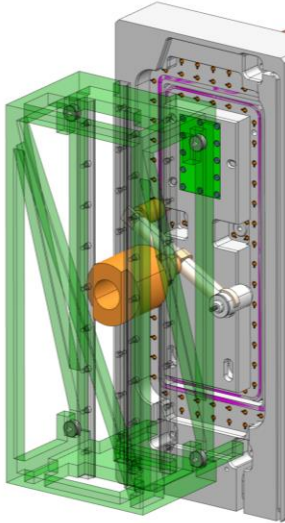
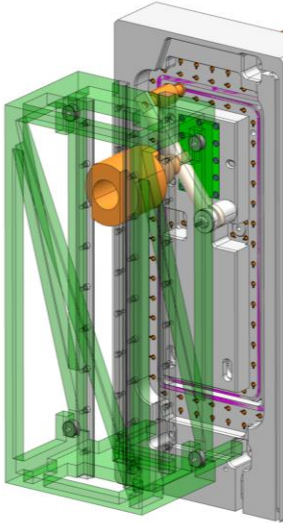
			
<p>Cleared flange, the pink rings are the sealing surfaces</p>	<p>Position polishing/inspection carriage</p>	<p>Forward robot to engage polisher</p>	<p>Robot follows sealing surface curve to refurbish it</p>

4.5.4. Helium leak testing carriage

For helium leak testing, a dedicated carriage can be brought up in the same manner. Its design is TBD.

5. GLOSSARY

Term	Definition
<<Sample term>>	<<Sample explanation >>

6. REFERENCES

- [1] ESS Drawing (ESS-0054148) Basement Handling
- [2] ESS Document (ESS-0051143) Maintenance Framework

Document Type Report
Document Number ESS-0044607
Date Apr 29, 2016
Revision 3
State Released
Confidentiality Level Internal

DOCUMENT REVISION HISTORY

Revision	Reason for and description of change	Author	Date
1	First issue	<<Name>>	<<YYYY- MM-DD>>

<<Keep only full number revisions when approving document>>
