

Beam Conditions during the Beam Commissioning

**R. Miyamoto
ESS AD/BPODG/BPS**

**3rd ESS Beam Diagnostics Forum
April 26-27th, 2017**

Outline and disclaimers

- Beam commissioning overview
- Beam conditions during beam commissioning
 - The conditions of the beam are a bit more complex than the standard beam modes. I try to provide some examples while going through the beam commissioning steps.
 - The presented examples are not meant to be comprehensive but rather to stimulate the discussion.
 - The working range of the devices have been already specified through the requirement table so I don't repeat the numbers here. I rather make a qualitative discussion and try to explain the physics of the situation.
- Conclusions

Beam Commissioning Overview

Timeline of beam commissioning (and selected ESS-wide milestones)

2018-02-05 ~ 2018-03-11	Beam commissioning up to LEBT
2018-09-17 ~ 2018-10-14	Beam commissioning up to MEBT
2019-01-28 ~ 2019-03-03	Beam commissioning up to DTL4
2019-06-10 ~ 2019-06-23	Beam commissioning up to tuning dump (570 MeV)
2020-04-xx	Target ready (no beam yet??)
2021-03-xx	First neutron instrument ready (first beam to target??)
2023-08-xx	User program starts
2025-xx-xx	5 MW beam power??

- **Rescheduling based on realistic delivery dates is ongoing.**
- Ion source and LEBT will be commissioned in Italy by the in-kind partner so what we do is re-commissioning.
- Linac Group is responsible for the source and the transition of the responsibility occurs during the LEBT beam commissioning.
- The beam power will be limited to 12 kW until the target is ready.

Normal conducting linac commissioning

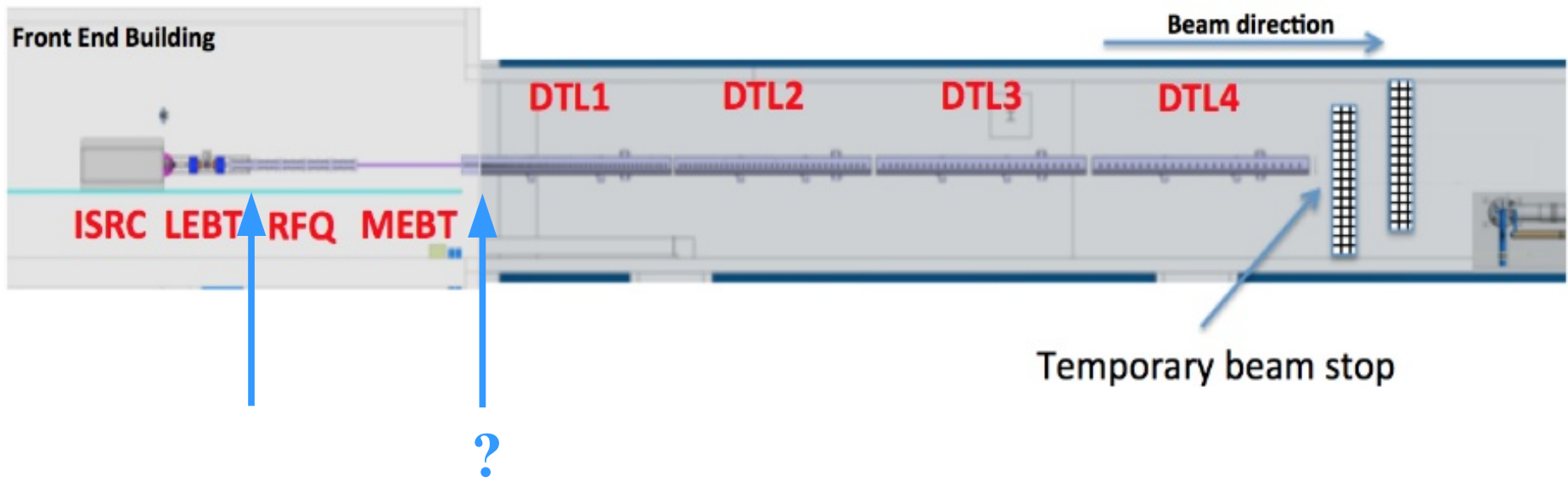

- Beam commissioning of the normal conducting linac is done in parallel to installations of the rest of the linac components.
- A temporary beam stop is used at each step.
- Beam parameters will be limited during these periods to limit the radiation dose.

Temporary and permanent beam stops

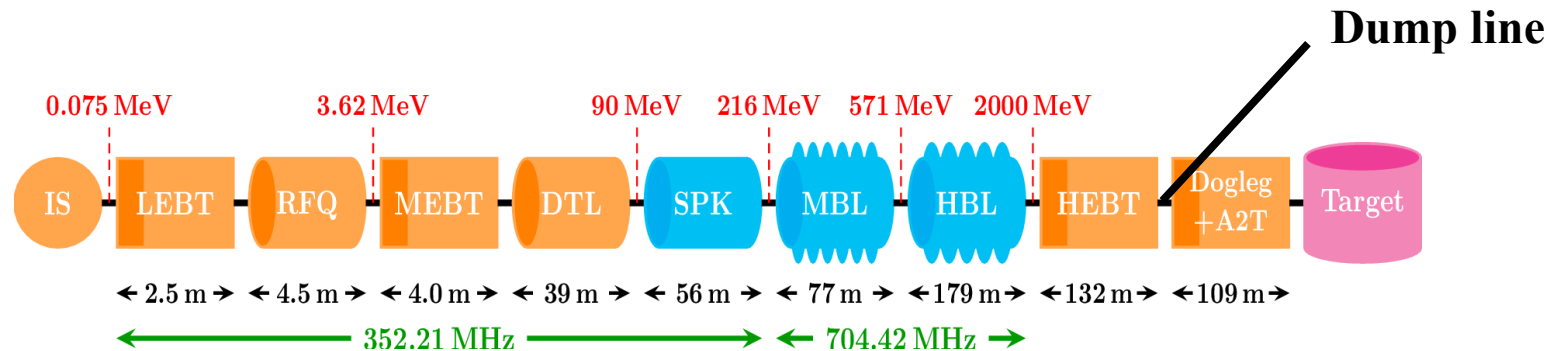

Location	Mode	Limits
LEBT (exit)	Temporary	1 Hz
LEBT (between the solenoids)	Permanent	N/A
MEBT (before the final quadruplet)	Permanent	(5 us, 14 Hz), (50 us, 1 Hz)
DTL (tank 2 exit)	Permanent	(5 us, 14 Hz), (50 us, 1 Hz)
DTL (tank 4 exit)	Permanent	(5 us, 14 Hz), (50 us, 1 Hz)
Spokes (doublet #1)	Permanent	(5 us, 14 Hz), (50 us, 1 Hz)
Medium- β (doublet #6)	Permanent	(5 us, 14 Hz), (50 us, 1 Hz)
Dump line	Permanent	(5 us, 14 Hz), (50 us, 1 Hz), 12 kW*
Target	Permanent	N/A

Beam modes

Section/type	Current [mA]	Pulse length [us]	Rep rate [Hz]	Main usages
IS, LEBT	6 - 90.0	≤ 6000	≤ 1	
RFQ, MEBT	6 - 62.5	≤ 50	≤ 1	
DTL1-4	6 - 62.5	≤ 50	$\leq 1?$	
Probe	6	≤ 5	≤ 1	- Initial check - Beam threading
Fast tuning	6 - 62.5	≤ 5	≤ 14	- RF setting
Slow tuning	6 - 62.5	≤ 50	≤ 1	- Invasive measurement - LLRF setting
Long pulse verification	6 - 62.5	≤ 2860	$\leq 1/30$	- Beam loss check - Lorentz detuning check

NCL commissioning

Standard

Beam Commissioning Steps

LEBT diagnostics layout

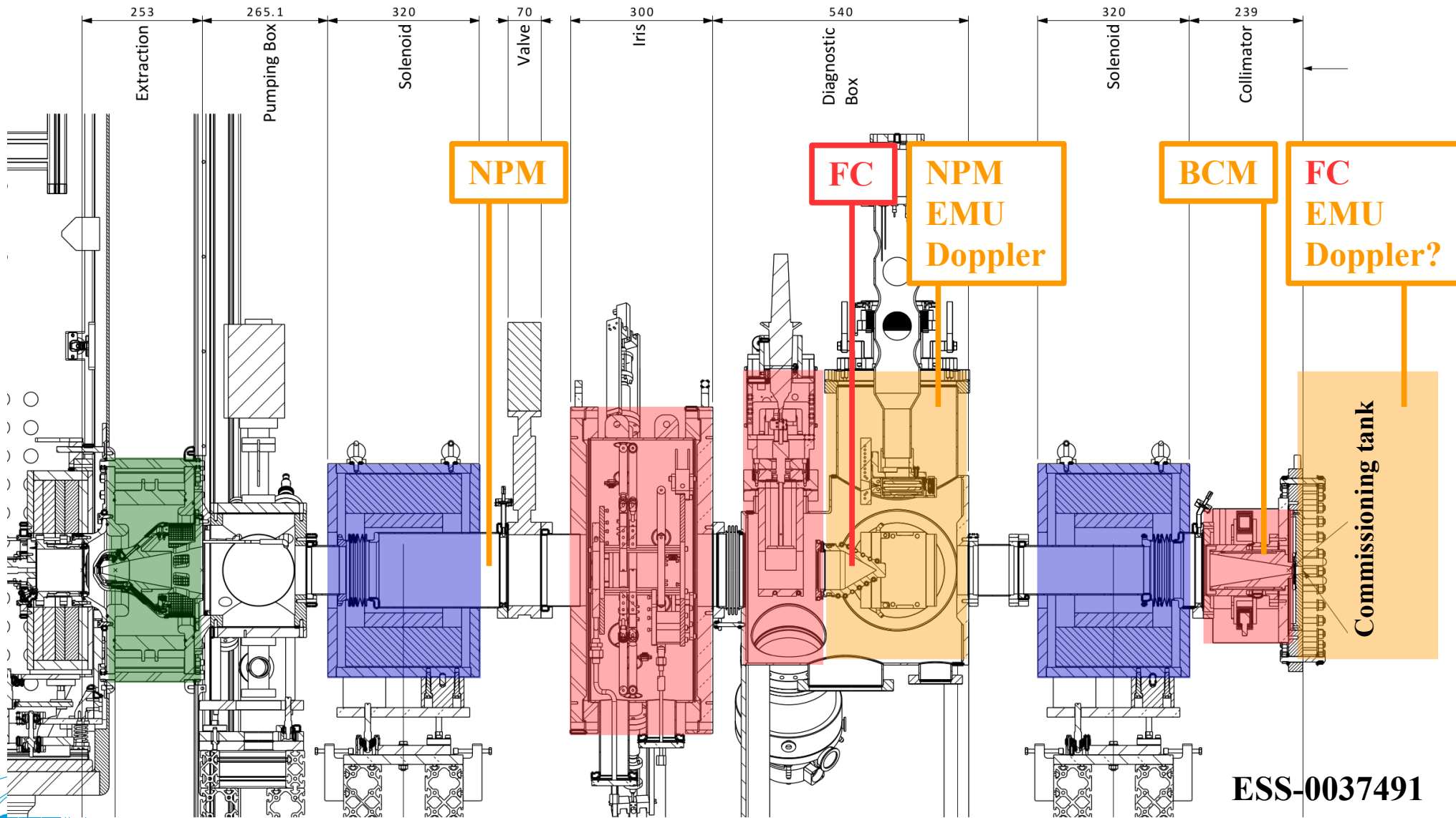

ESS-0037491

Time structure evolution

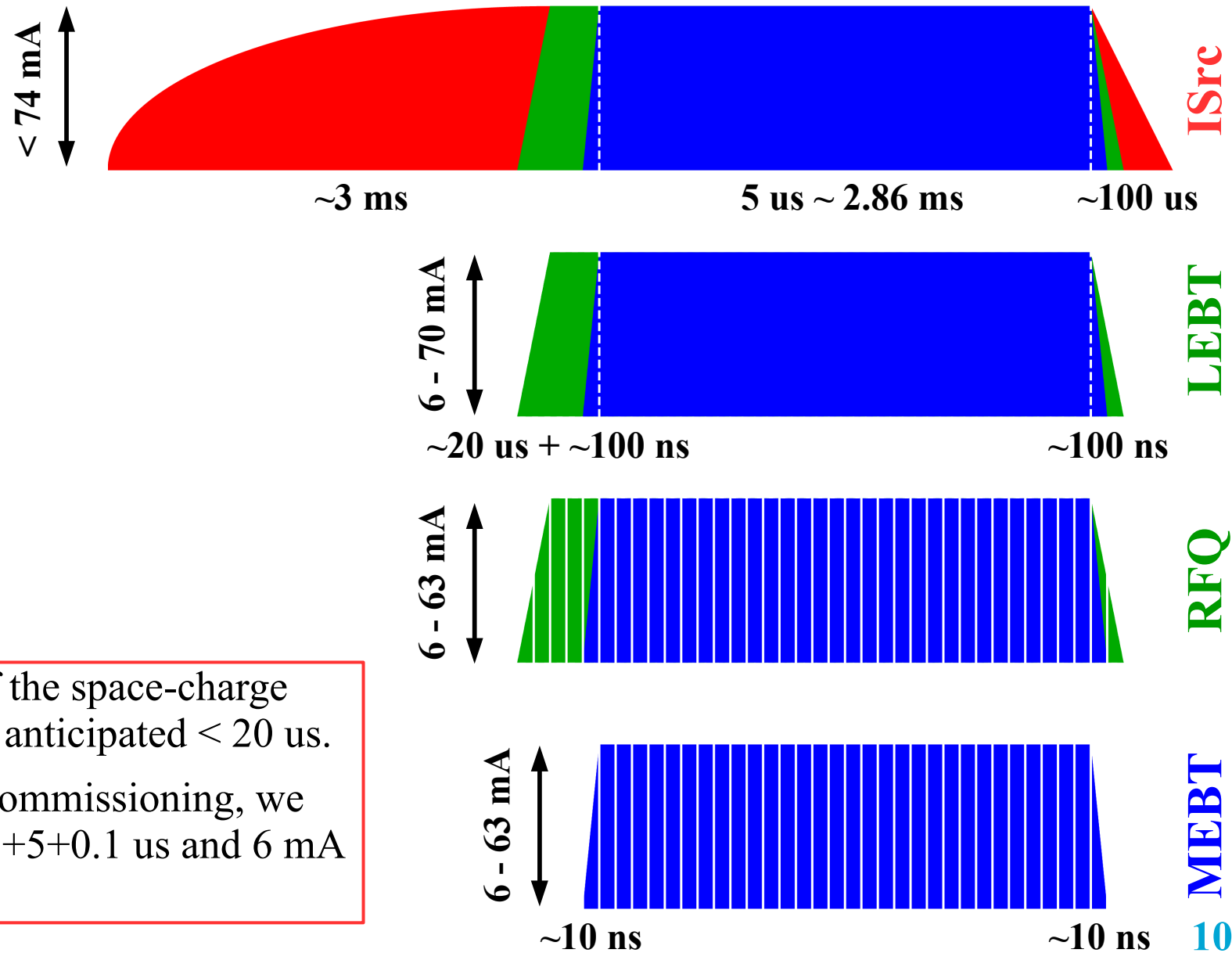

- Build up time of the space-charge compensation is anticipated $< 20 \text{ us}$.
- For the MEBT commissioning, we may also use $0.1+5+0.1 \text{ us}$ and 6 mA out of LEBT.

Pulse stability

Courtesy of B. Cheymol

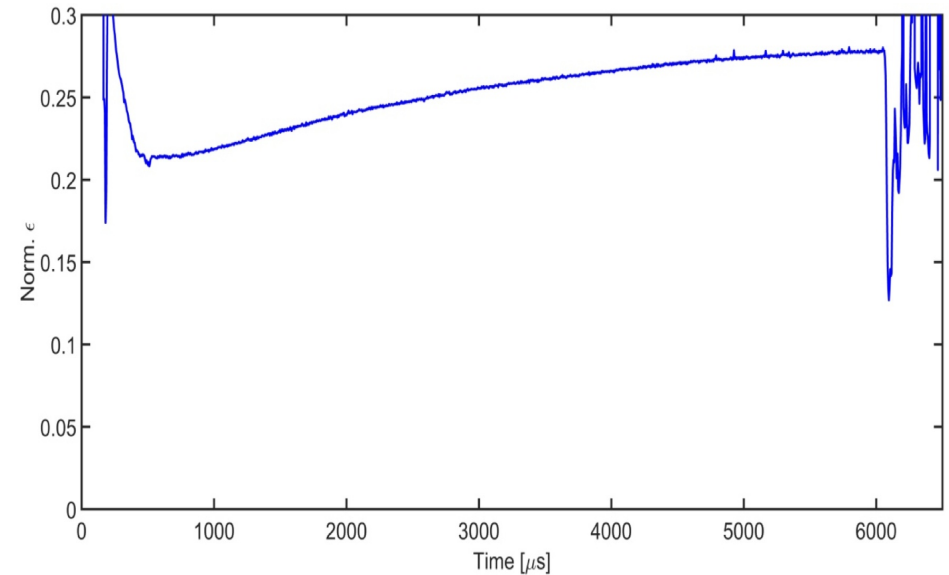
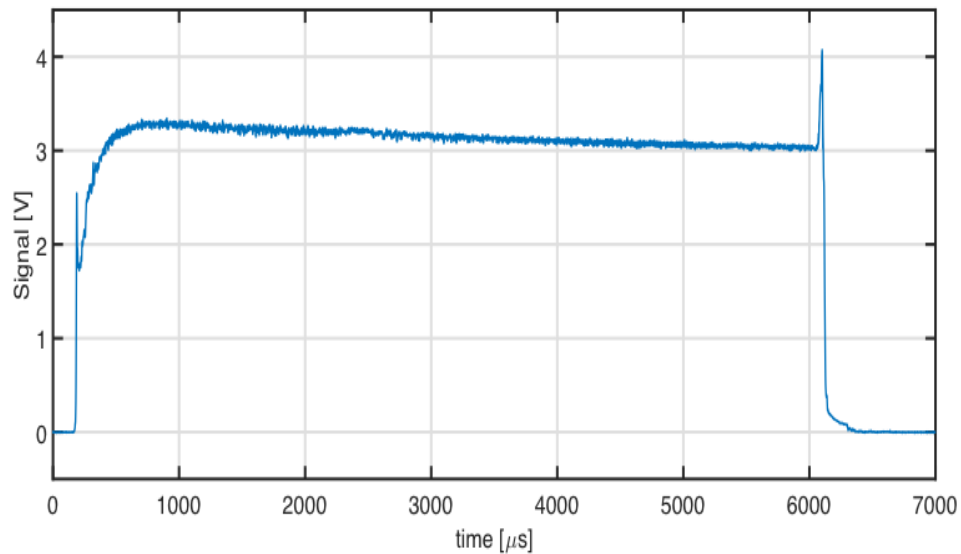

- **Preliminary** measurements of the current and emittance evolution within the pulse.
- Similar measurements are useful throughout the linac.

Space charge compensation

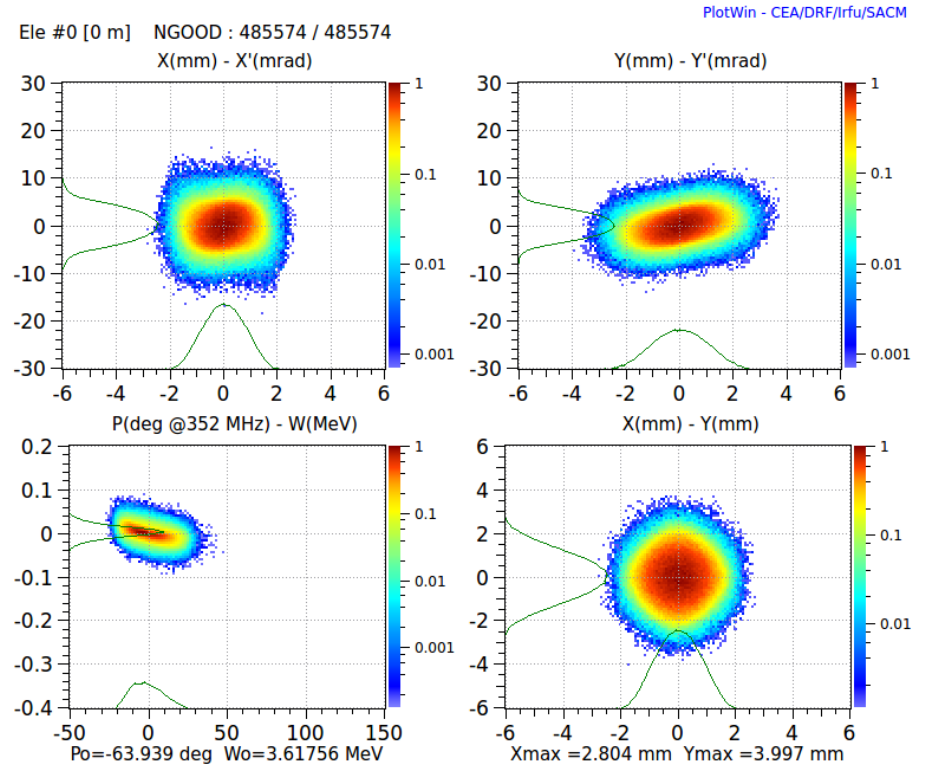
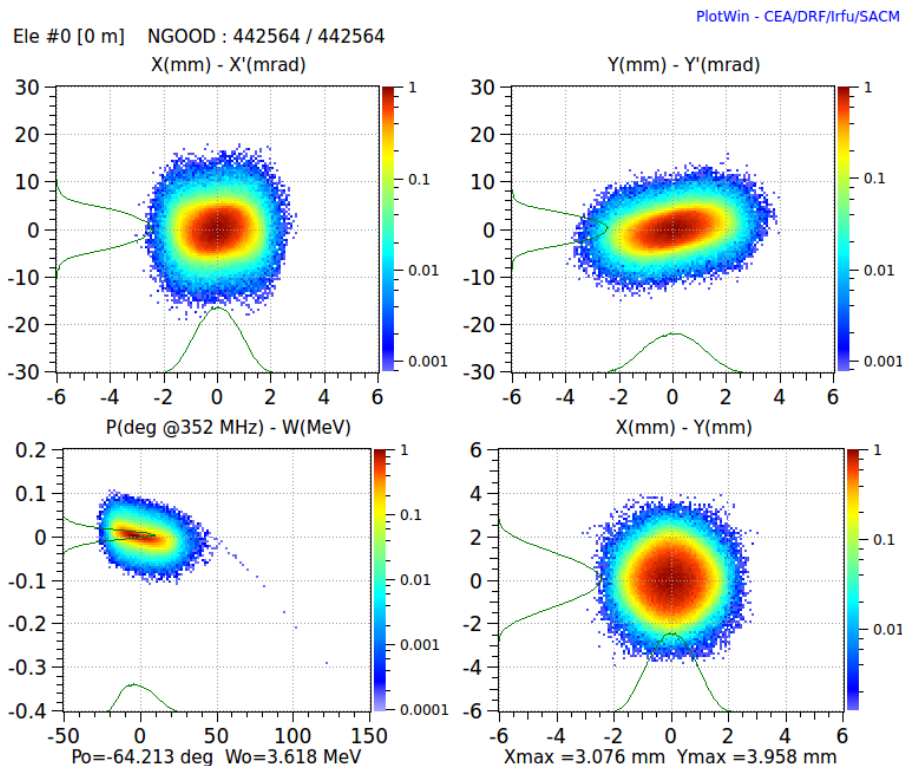

- RFQ output with 90% vs 95% (nominal) compensation levels.
- When the level is lowered to 90%,
 - transmission at the RFQ exit lower by $\sim 9\%$.
 - emittances at the RFQ exit larger by $\sim 4\%$ for x and y and $\sim 8\%$ for z .
 - 0.01 - 0.1 W level losses within DTL with no error.

MEBT layout

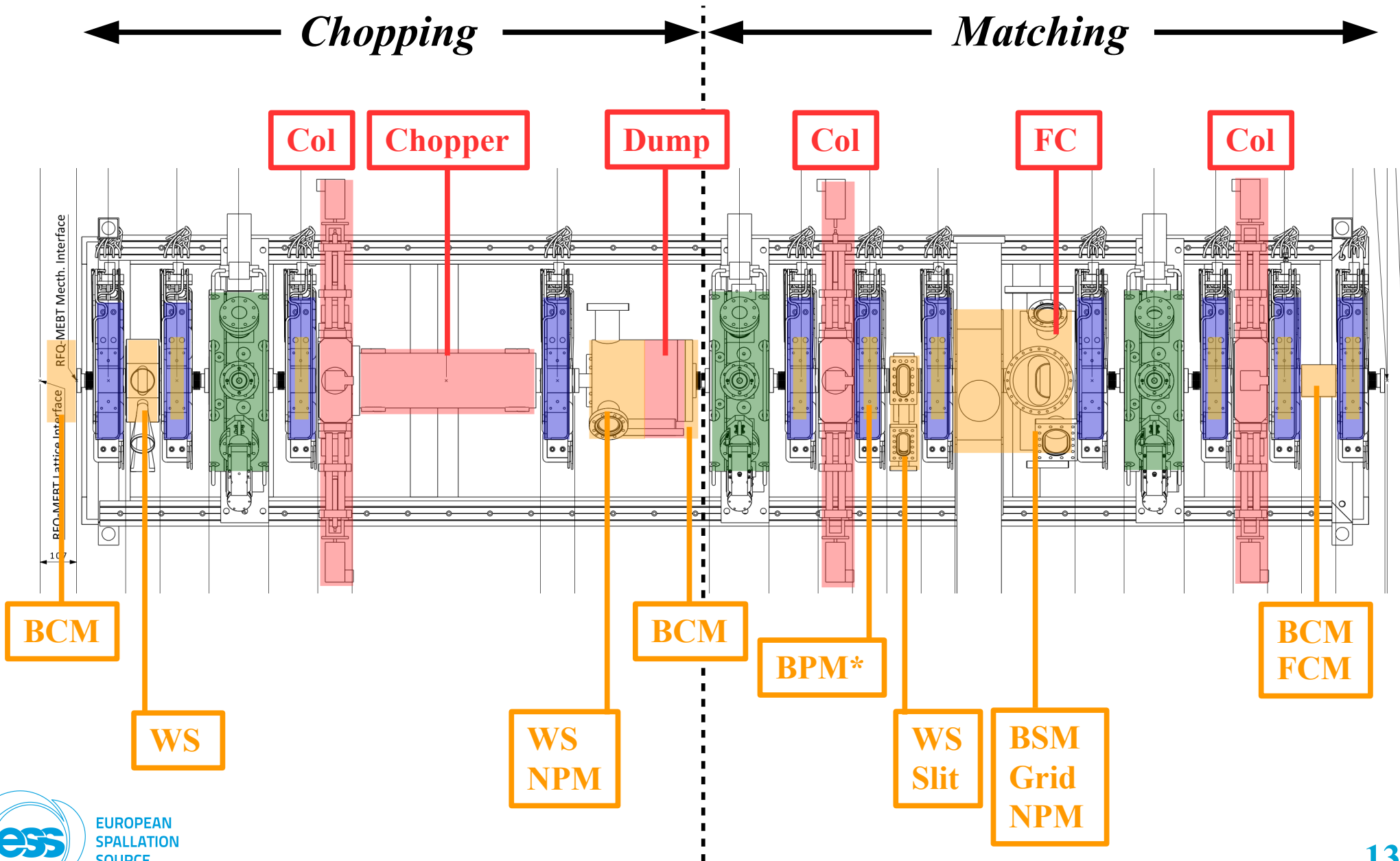

RFQ+MEBT tuning

Knob	Beam parameter	Diagnostics
RFQ power	Energy Transmission	BPM BCM
Steerers	Trajectory	BPM
Buncher 1 phase	Energy*	BSM
Buncher 1 amp	Bunch length	BPM
Buncher 2-3 phase	Energy*	BSM
Buncher 2-3 amp	Twiss (z)	BPM
Quad 1-4	Beam size (x,y) in <i>chopping</i>	WS (EMU)
Quad 5-11	Twiss (x,y) Beam size (x,y) in <i>matching</i>	EMU (WS) WS (EMU)
Chopper	Pulse edge	BPM*, FCM
Collimator	Halo (x,y) Pulse edge	Built-in sensor (WS, EMU) BPM*, FCM

RFQ distribution

Ele #0 [0 m] NGOOD : 985398 / 985398
X(mm) - X'(mrad)

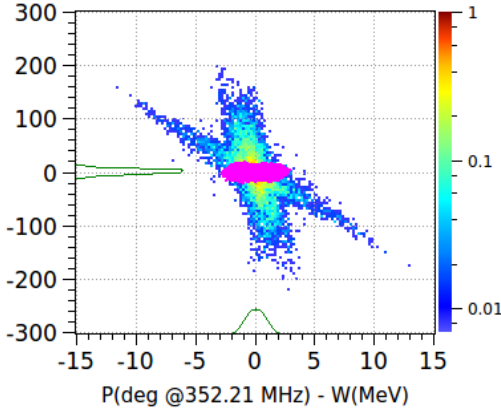

Y(mm) - Y'(mrad)

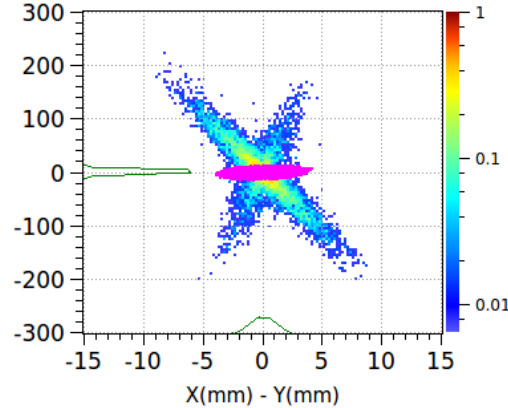

P(deg @352.21 MHz) - W(MeV)

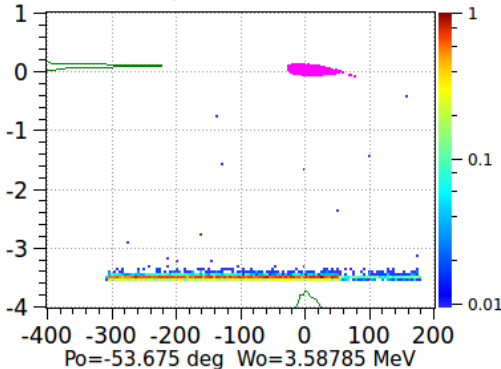

X(mm) - Y(mm)

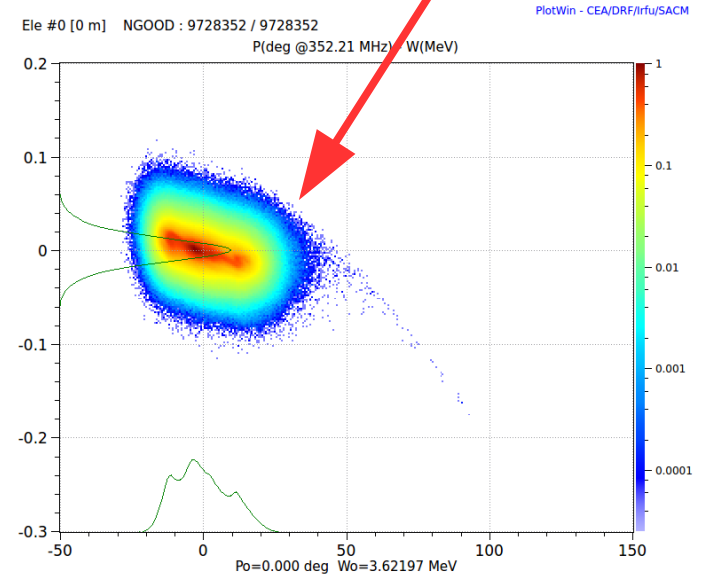
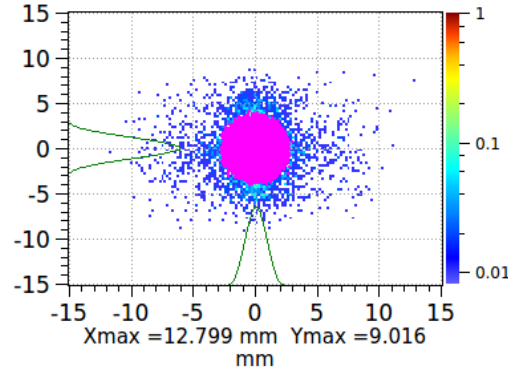

- RFQ output includes uncaptured particles.
- The longitudinal distribution includes “tail”. (Could be the continuum down to the source energy.)
 - Particles in the tail are lost within the normal conducting part.
 - The most dangerous part is the “base” of the tail, which is the major source of the loss in the error study in combination with the frequency jump.

Beam loading

- The RFQ is the first cavity among many in our linac and from here we have the bunched beam and beam loading effect.
- The time scale of the beam loading and LLRF compensation (feed-forward and feedback) is the order of 1-10 μs (throughout the ESS linac). This is one of the reason for the 50 μs of the slow tuning mode.
- We are expecting that the diagnostics devices allow us to sample within the 50 μs pulse. This is especially for the BLMs since the beam physics is almost “passive” on this.

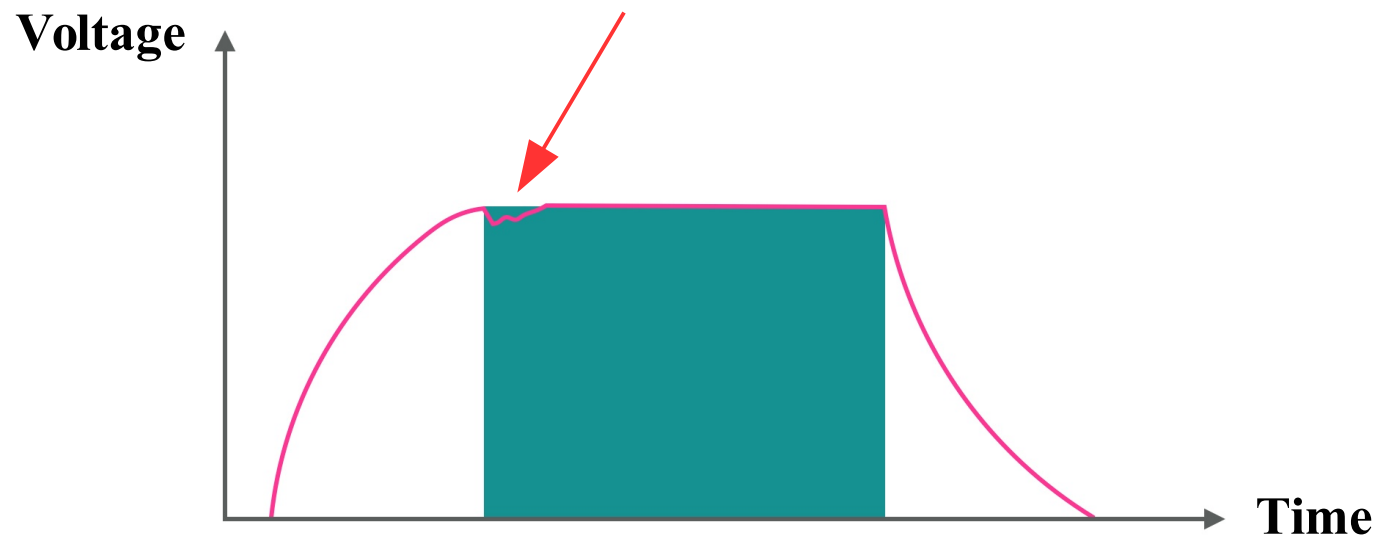

Fast BCM for the chopper efficiency measurement

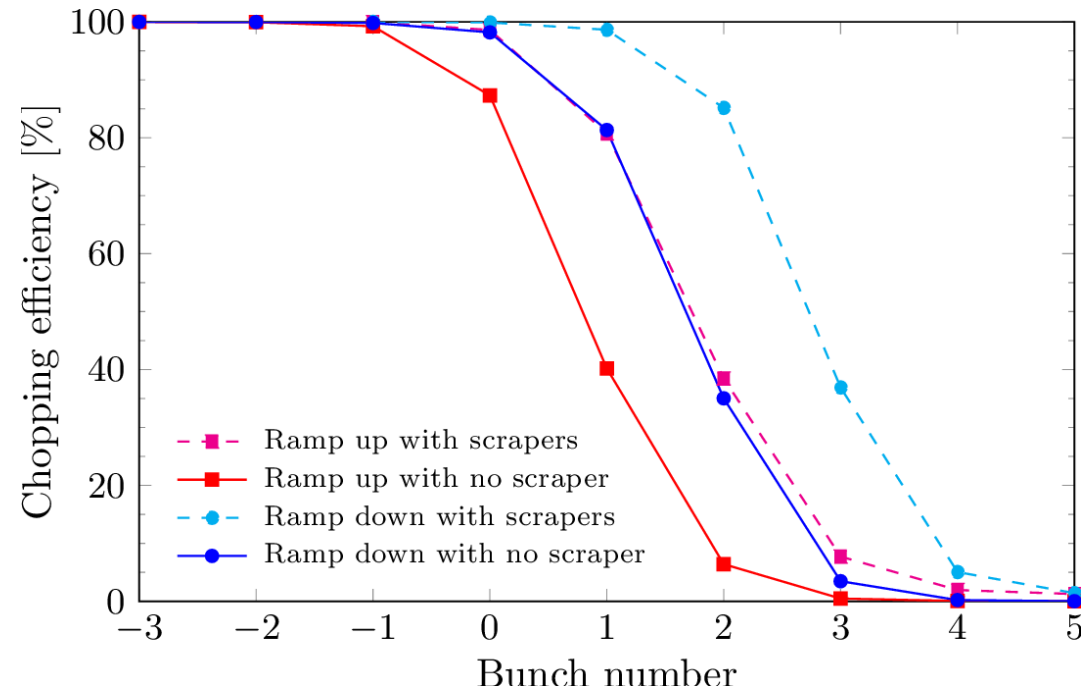
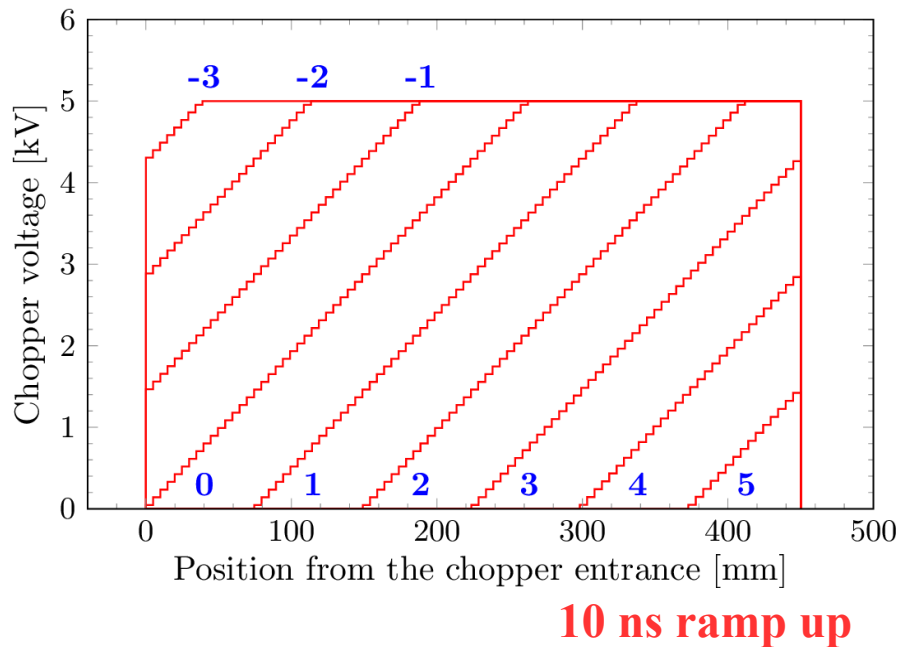

- MEBT houses two fast beam current monitors to check the pulse edges after the fast chopping.
- After the fast chopper, no more change in the time structure of the beam.

DTL layout and tuning

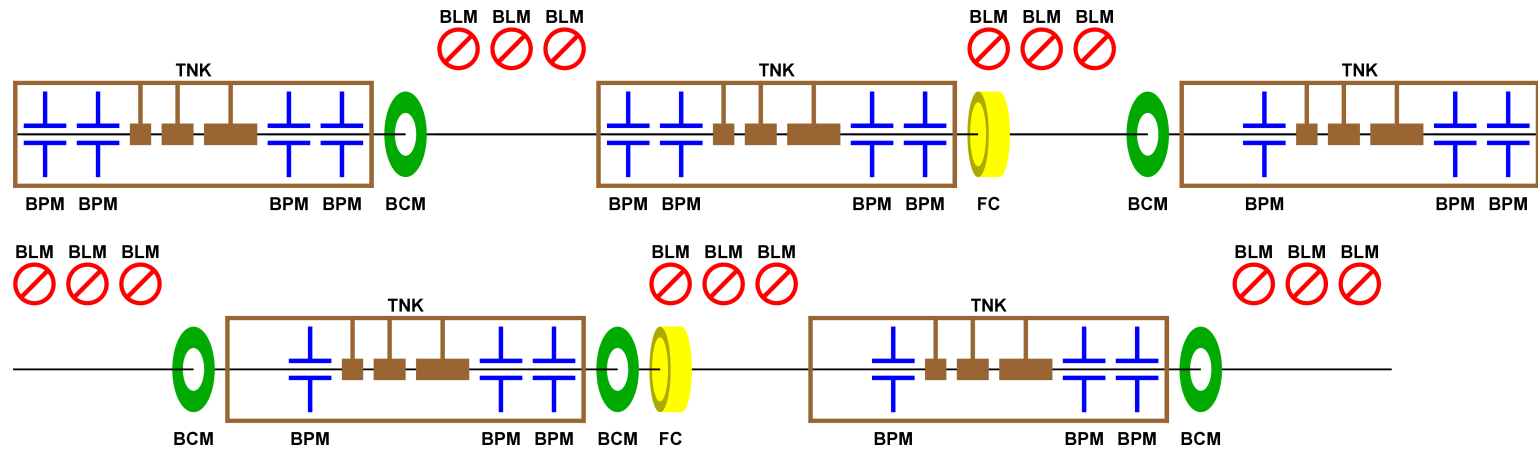

The actual number of BPMs in each tank is 6, 3, 2, 2, 2.

Knob	Beam parameter	Diagnostics
Steerers	Trajectory	BPM
Tank 1 phase	Energy Transmission	BPM BCT
Tank 1 amp	Energy	BPM
Tank 2-5 phase, amp	Energy	BPM

DTL

- RF phase scan with the probe beam dominates the time of the DTL commissioning. The full current beam is used only for the LLRF setting and checking of the transmission and loss.
- Phase scan
 - If DTL#1 doesn't have the correct phase and amplitude, the beam is completely lost within DTL#1.
 - Once the RF of the DTL#1 is properly set, the beam reaches to the end of DTL, even if one of the tanks has completely wrong phase. This is due to the nature of the strong transverse focusing of the DTL lattice. Because of this, transverse beam sizes do not change between the low and full currents or for the intermediate energies. (The debunching effect, to be checked.)

Spoke section layout and tuning

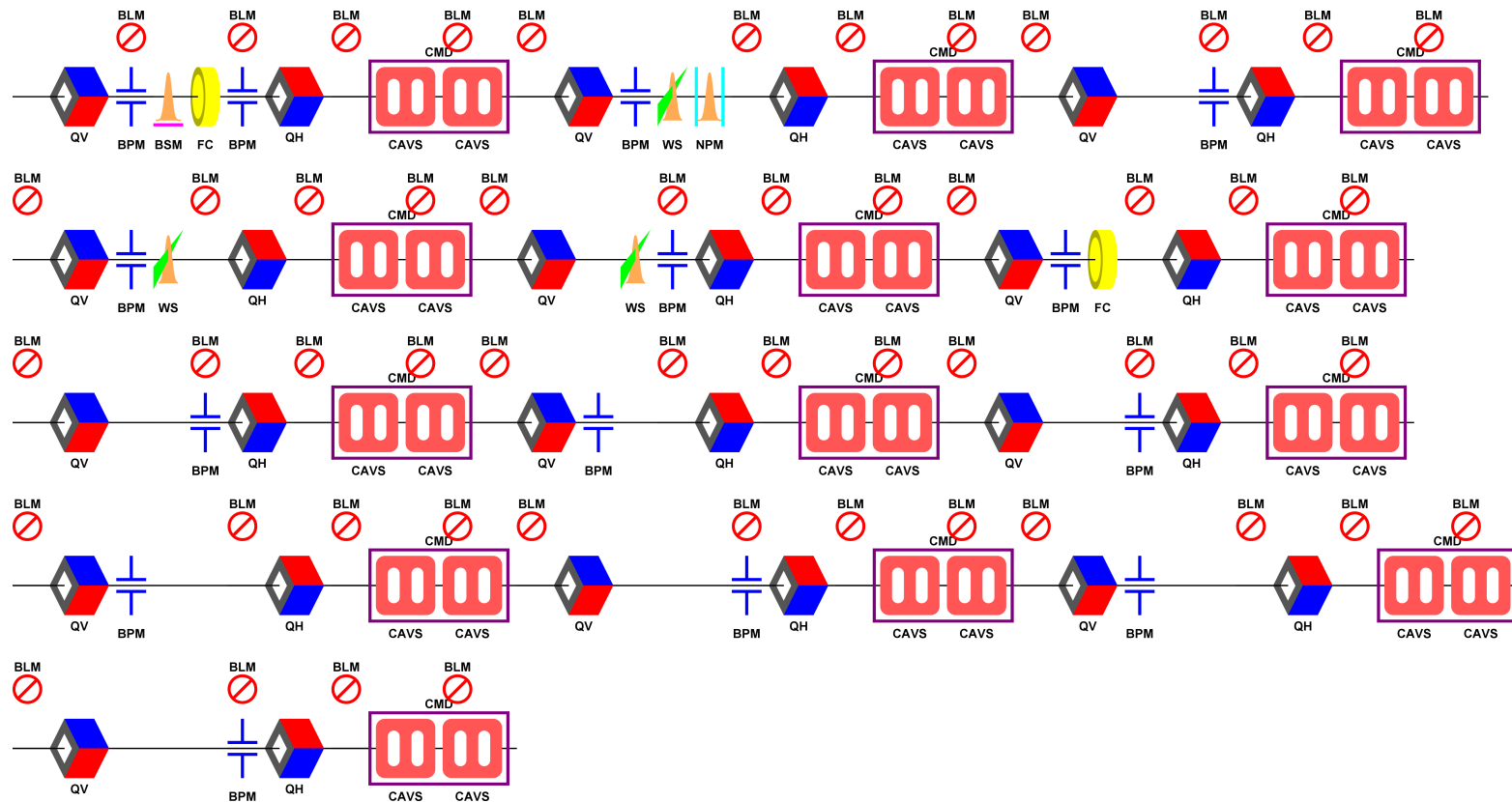

- Major part of the tuning of the spoke section is the phase scans for 26 cavities.
- 1 BPM per period. The location alternates near Qh and Qv. (The same in the rest of the linac, except in A2T.)
- Matching at the interfaces.
 - 3 WSs and 1 BSM in the initial part allow the transverse and longitudinal matching.
 - To DTL: the design uses 4 cavities and 4 quads.
 - To Medium- β : the design uses 2 cavities and 2 quads.

Medium- β linac layout and tuning

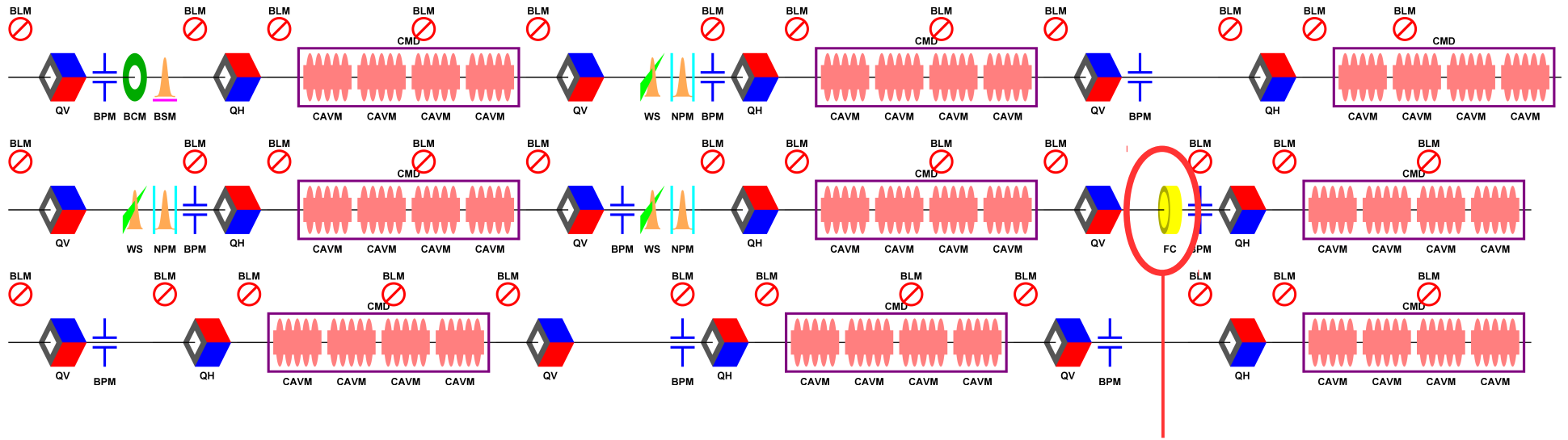

Only the beam beyond this point is sent to the tuning dump

- Major part of the tuning of the medium- β is the phase scans for 36 cavities.
- Matching at the interfaces.
 - Due to the frequency jump, the spoke and medium- β interface is one of the most vulnerable points in the linac.
 - 3 WSs and 1 BSM in the initial part allow the transverse and longitudinal matching.
 - To spoke: the design uses 8 cavities and 2 quads.
 - To high- β : the design uses 4 cavities and 2 quads.

High- β linac layout and tuning

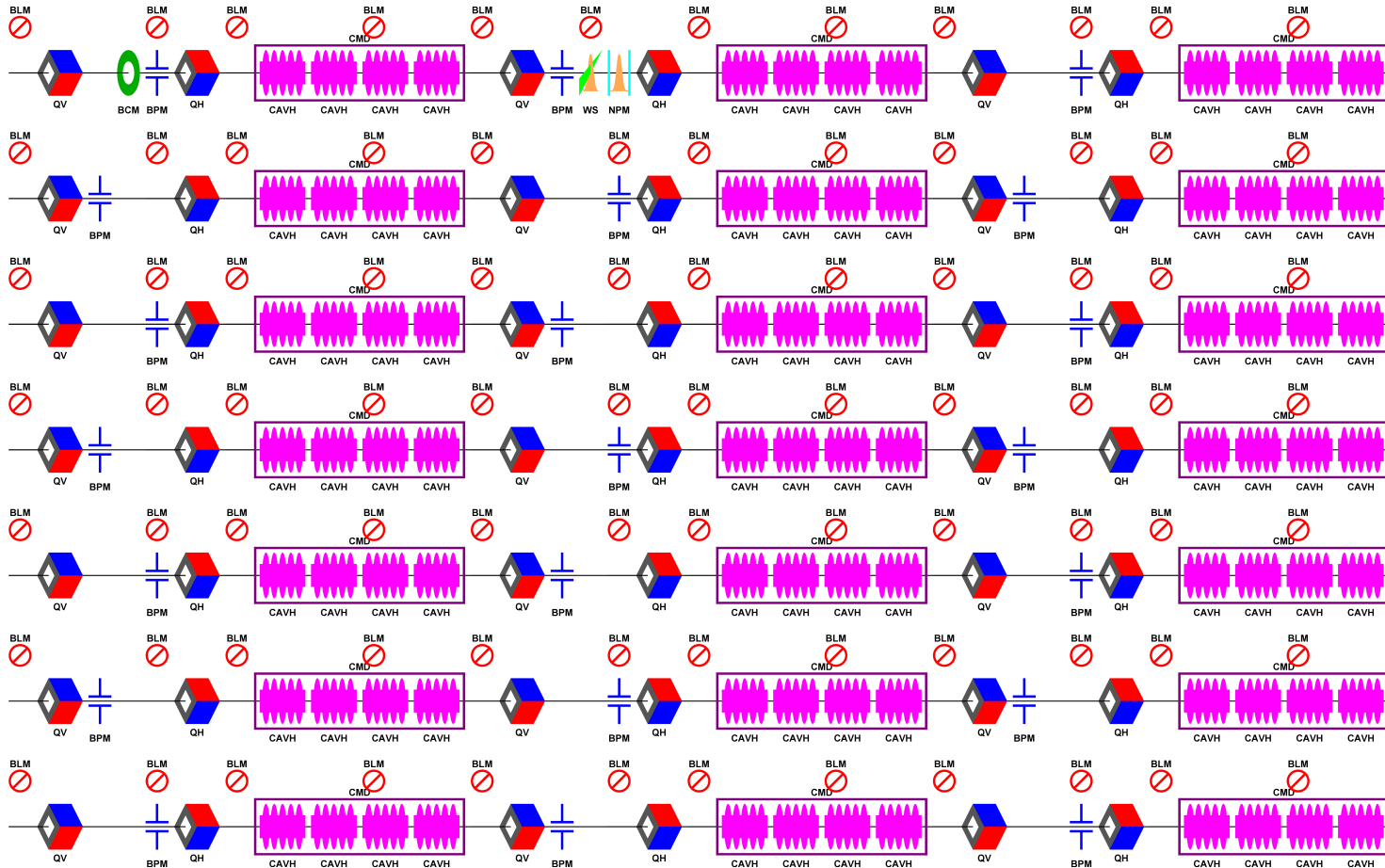

- Major part of the tuning of the medium- β is the phase scans for 36 cavities.
- Matching at the interfaces.
 - Because of no change in lattice periodicity, there is only 1 WS as a placeholder.
 - To medium- β : the design uses 4 cavities and 2 quads.

HEBT and dogleg layout and tuning

HEBT

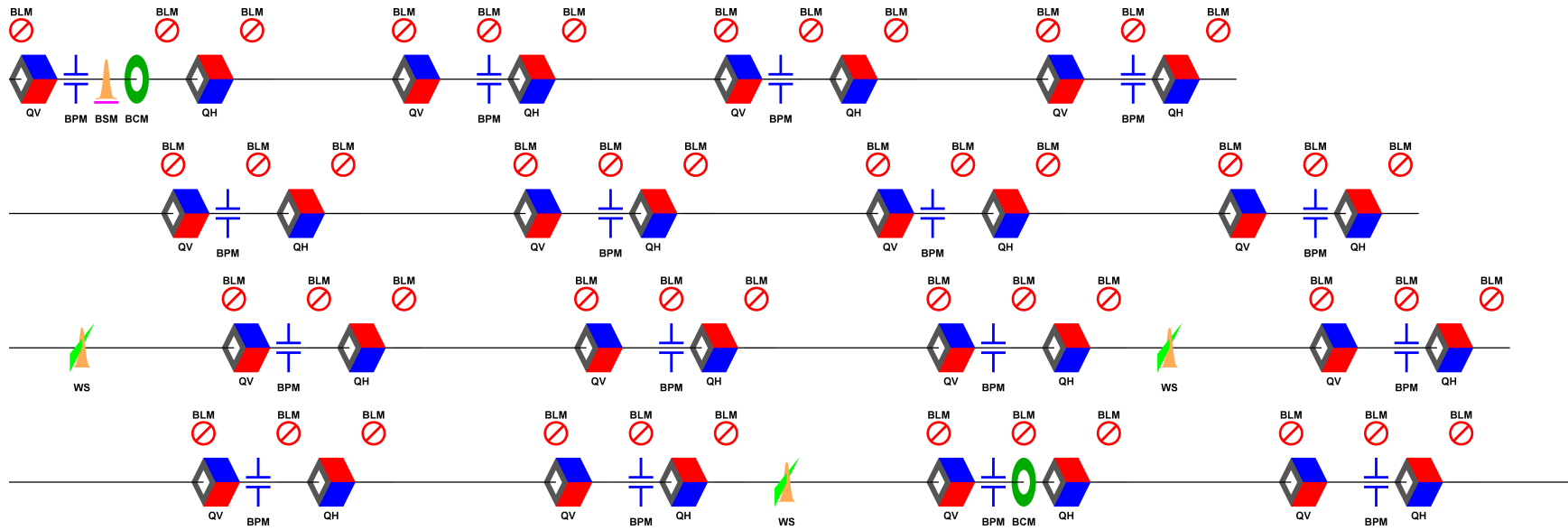

Dogleg

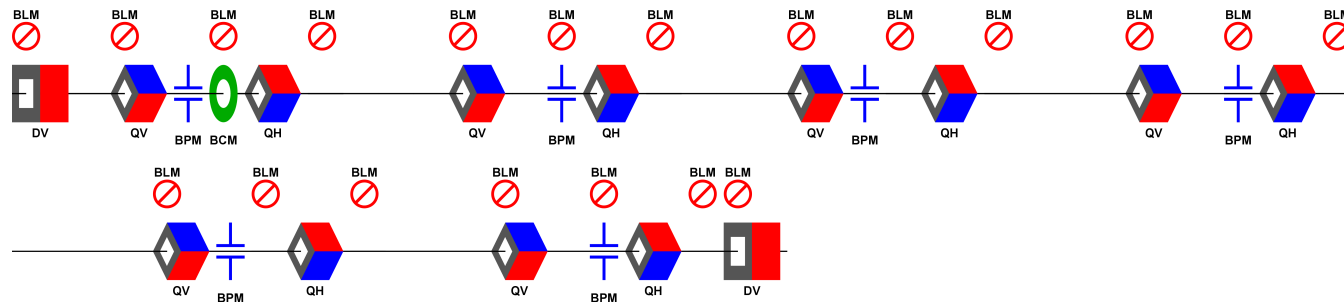

- Matching at the interfaces.
 - 3 WSs in the later part of the HEBT allows the emittance measurement and matching.
 - To high- β : the design uses 8 quads.
- Dispersion is measured with BPMs in A2T.

Debunching and mismatch during the phase scan

- During the process of the RF setting with the phase scan, the beam is debunched. This is most significant in the SC linac. A rough beam steering must be still performed with the debunched beam.
- The beam is also mismatched during this process. If the mismatch is too large, the beam could be lost. On the other hand, we don't want to prepare infinite number of lattices.
- The beam size on the tuning dump varies depending on the condition. The acceptable range is to be determined.

Debunching of 6 mA and 216 MeV beam

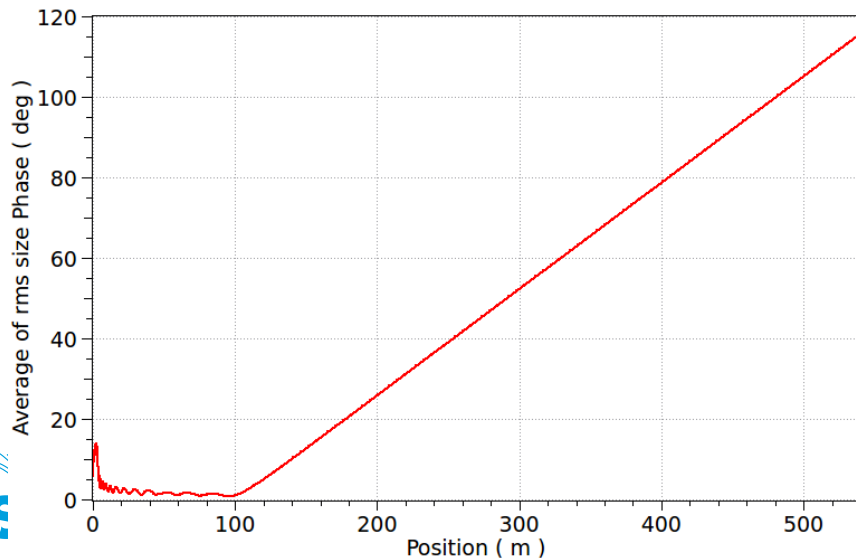

6 mA and 216 MeV beam in the nominal lattice

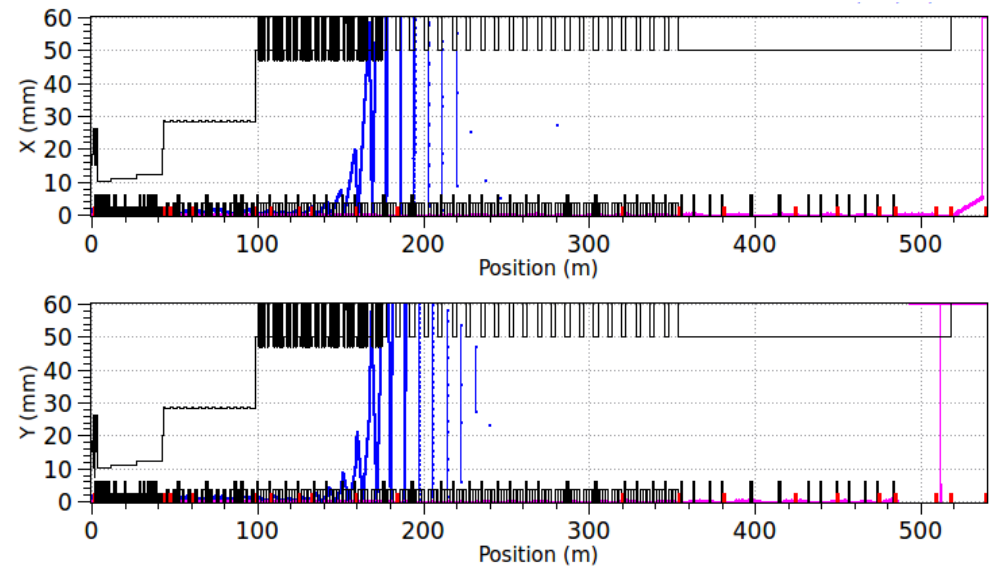

A2T tuning

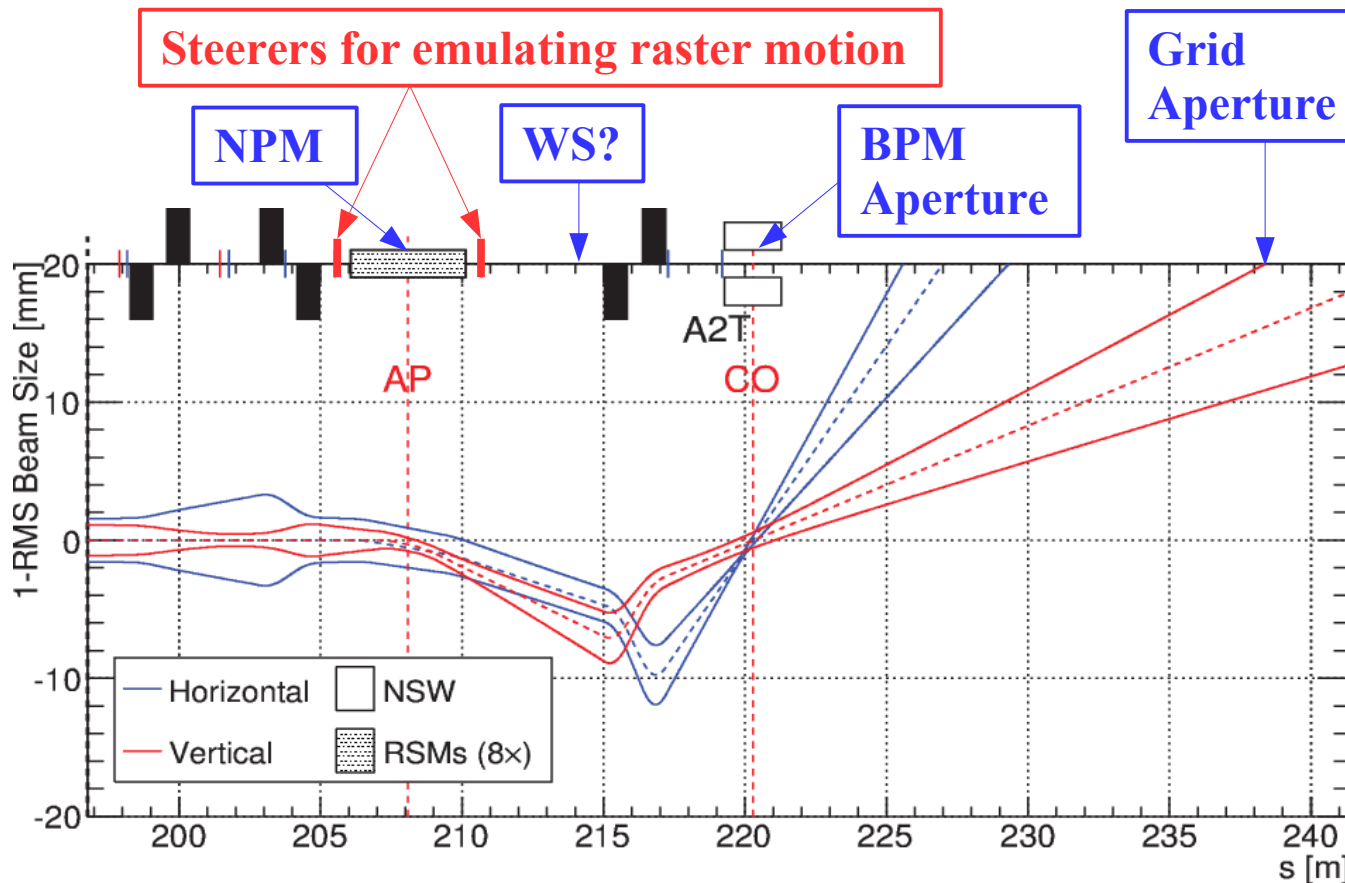

- **Before sending the beam to A2T, the beam should be well-behaving.**
- Devices after the raster system see the real and simulated raster motions.
- The test of the real raster system is first tried with the low current and shorter pulse.

Knob	Beam parameter	Diagnostics
Steerers	Trajectory	BPM, image, grid
Quad 5-6	AP to CO phase advance	BPM at CO (w/ raster steerers)
Quad 1-4	Beam sizes on the target Beam sizes (waists?) in NSW	Image, grid (NPM, WS?) NPM, WS? (image, grid)
Raster	Footprint on the target	Image, grid (w/ raster steerers)

Power ramp-up and Lorentz detuning

- The Lorentz detuning effect does not decay like the beam loading and change throughout the pulse.
- Many neutron instruments of ESS require the full 2.86 ms pulse and so the compensation of this effect is crucial for the ESS operation.
- The pulse length ramp-up is done by sending the beam to the tuning dump while doing the monitoring with the non-invasive devices. Thus, the non-invasive devices are required to be able to sample within a pulse.
- If the effect is large and compensation isn't good enough, we may need to do the “sampling” of the 50 us mini-pulse over the 2.86 ms. The diagnostics should be able to work in this way too.



Conclusions

Conclusions

- Overview of the present beam commissioning plan was provided.
 - Beam commissioning will start early next year from the re-commissioning of the ion source and LEBT.
 - In mid-2019, we will be ready to send the 570 MeV low power (<12 kW) beam to the tuning dump.
 - The power ramp-up will be performed after the target becomes ready in 2020. This makes the current focus on the basic tunings such as the RF phase and amplitude.
- Beam conditions beyond the standard beam modes, encountered during the beam commissioning, were discussed.

Backup slides

ISrc+LEBT tuning

Courtesy of Ø. Midttun

Knob	Beam parameter	Diagnostics
Microwave, B field, Gas	Current Proton fraction	(HV, FC, BCM) Doppler
HV	Energy	HV power supply (Doppler)
Microwave	Pulse length	HV, FC
Chopper	Pulse length	BCM
Steerers	Trajectory Transmission (RFQ)	NPM, EMU BCM (MEBT)
Solenoids	Twiss (x,y) Transmission (RFQ)	EMU BCM (MEBT)
Iris	Current	FC, BCM
Gas	Emittance, Twiss (x,y) Transmission (RFQ)	EMU, NPM BCM (MEBT)

- Tuning of the LEBT is mostly scanning a knob and checking the corresponding diagnostics device.
- We need applications for 1D and 2D scans.

A2T layout

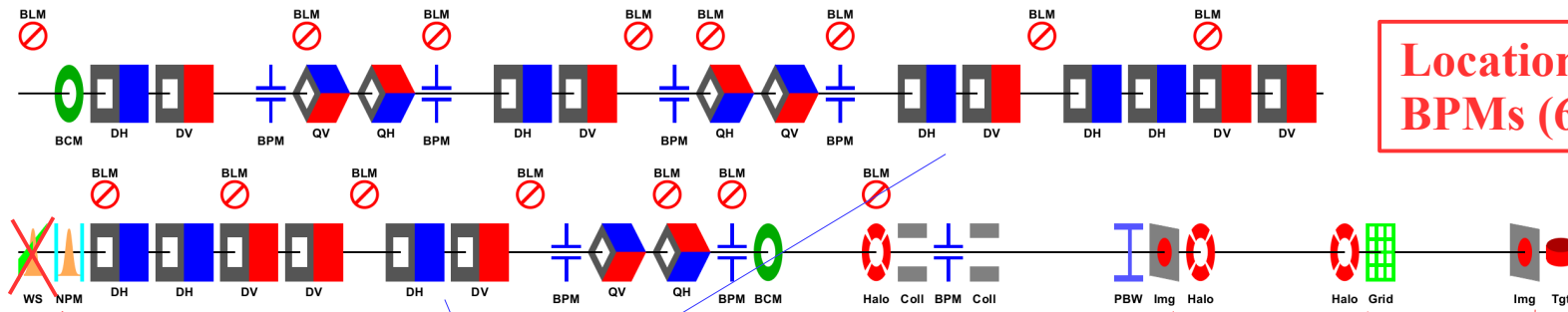

Locations of steerers (4) and BPMs (6) being updated

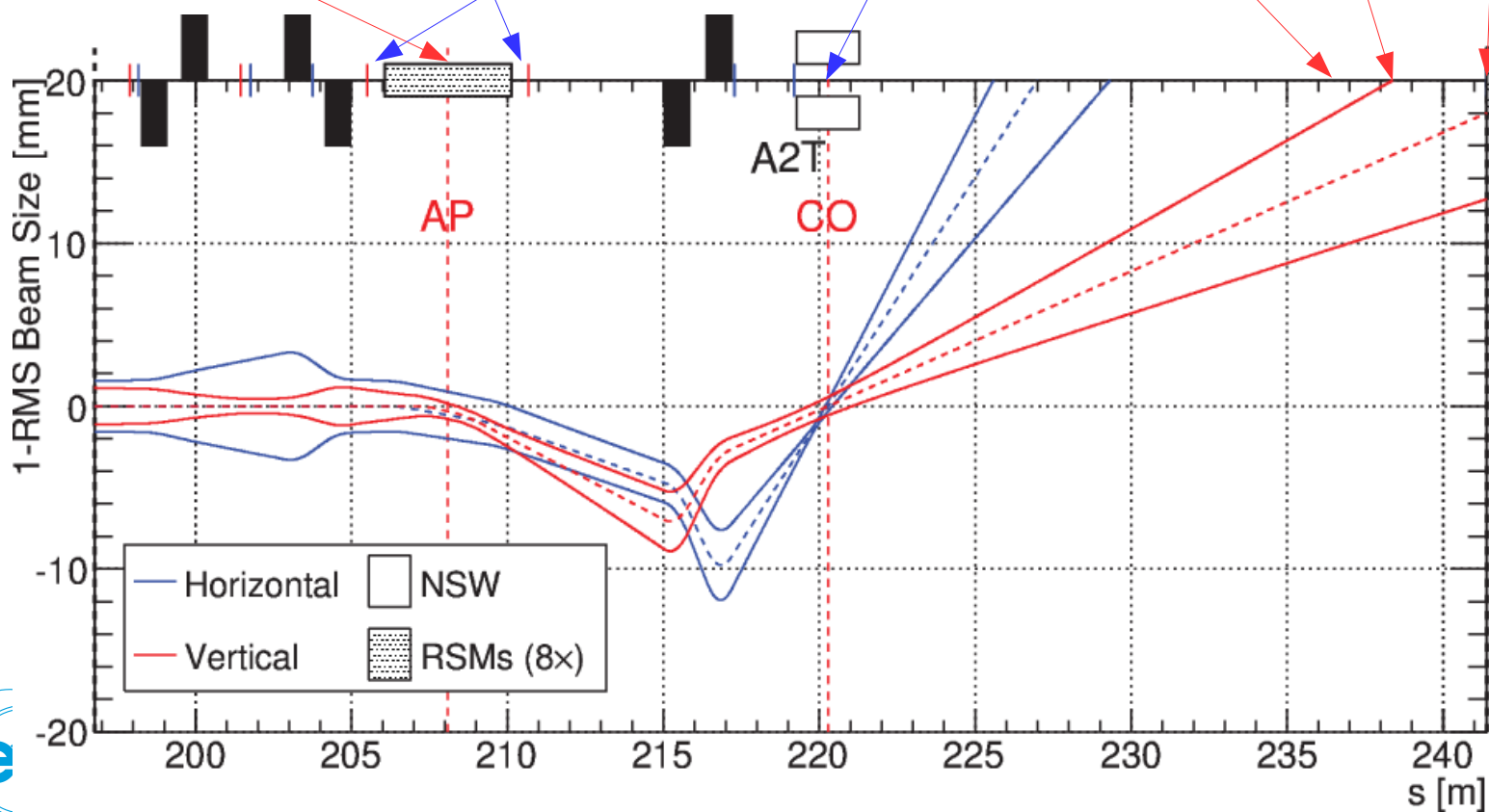

Courtesy of H. Thomsen