

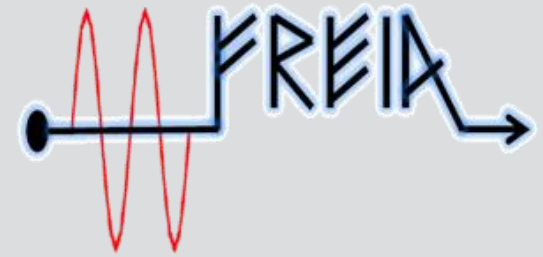

UPPSALA
UNIVERSITET



RF tests of ROMEIA and its coupler in HNOSS

Han Li

On behalf of FREIA team

FREIA Laboratory, Uppsala University

9th of Jun. 2017

Han Li, 9th Jun. 2017

➤ FREIA has developed the prototype spoke RF source and validated the prototype spoke cavity and, will validate spoke cryomodule, prototype high-beta elliptical cavity with nominal RF power.

1) Validation of high power RF amplifier (HPA)

2) Validation of dressed spoke cavity

3) Validation of cavity package

- ✓ Prototype cavity package (in test cryostat)
- ✓ Requires the availability of one high power RF amplifier tested during phase 1

4) validation of elliptical cavity package

5) Validation of spoke prototype cryomodule

6) validation of prototype modulator and klystron

7) Acceptance testing of series spoke cryomodules

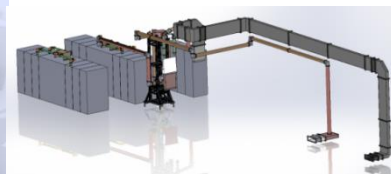
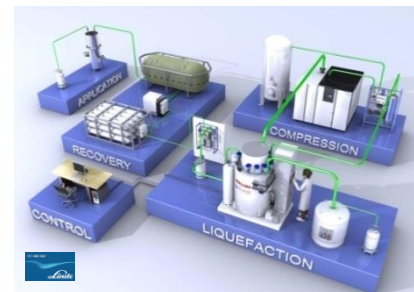
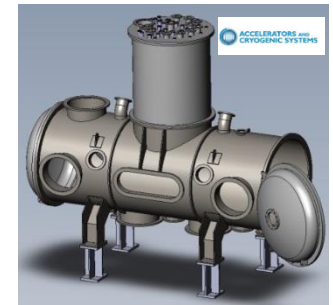
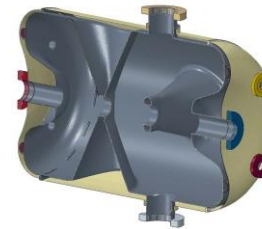
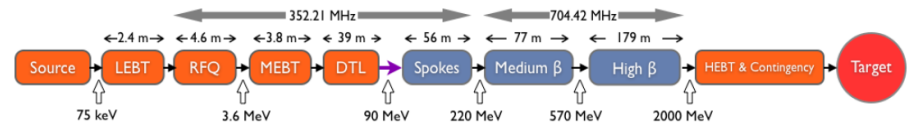

➤ Test of cavity package.

➤ This test has the following goals:

- ✓ verify cooling procedures,
- ✓ verify power coupler conditioning procedure, coupler ability and performance,
- ✓ verify cavity intrinsic ability, accelerating performance, mechanical behaviour,
- ✓ verify LLRF ability and performance,
- ✓ verify the high power RF amplifier ability and performance in combination with the cavity and LLRF,
- ✓ verify cold tuning system (CTS) ability and performance,
- ✓ achieve nominal RF pulse.

➤ Typical measurements:

- ✓ RF behaviour during cool down,
- ✓ Coupler conditioning and cavity package conditioning,
- ✓ Achieve nominal gradient and nominal Q_0 ,
- ✓ Cryogenic heat loads,
- ✓ Loaded Q-factor, eigen and external Q, $Q_0 = f(E)$ curve,
- ✓ Dynamic Lorentz detuning and mechanical modes,
- ✓ Field emission onset and multipacting barriers,
- ✓ Sensitivity to helium pressure fluctuations,
- ✓ Tuning sensitivity.

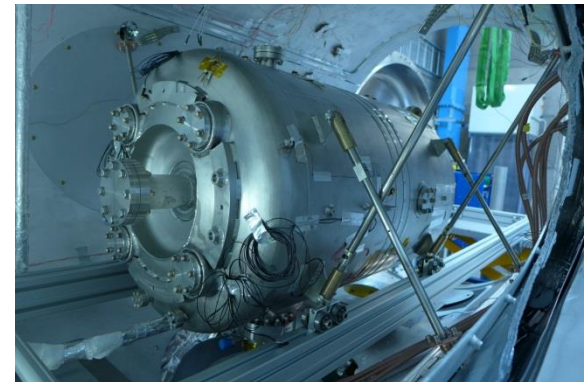

The Self-excited Loop Test Stand (I)



- FREIA developed a test stand based on SEL for superconducting cavities under a pulse mode test at high power level.
- Help with the determination of cavity performance without tuner feedback system.

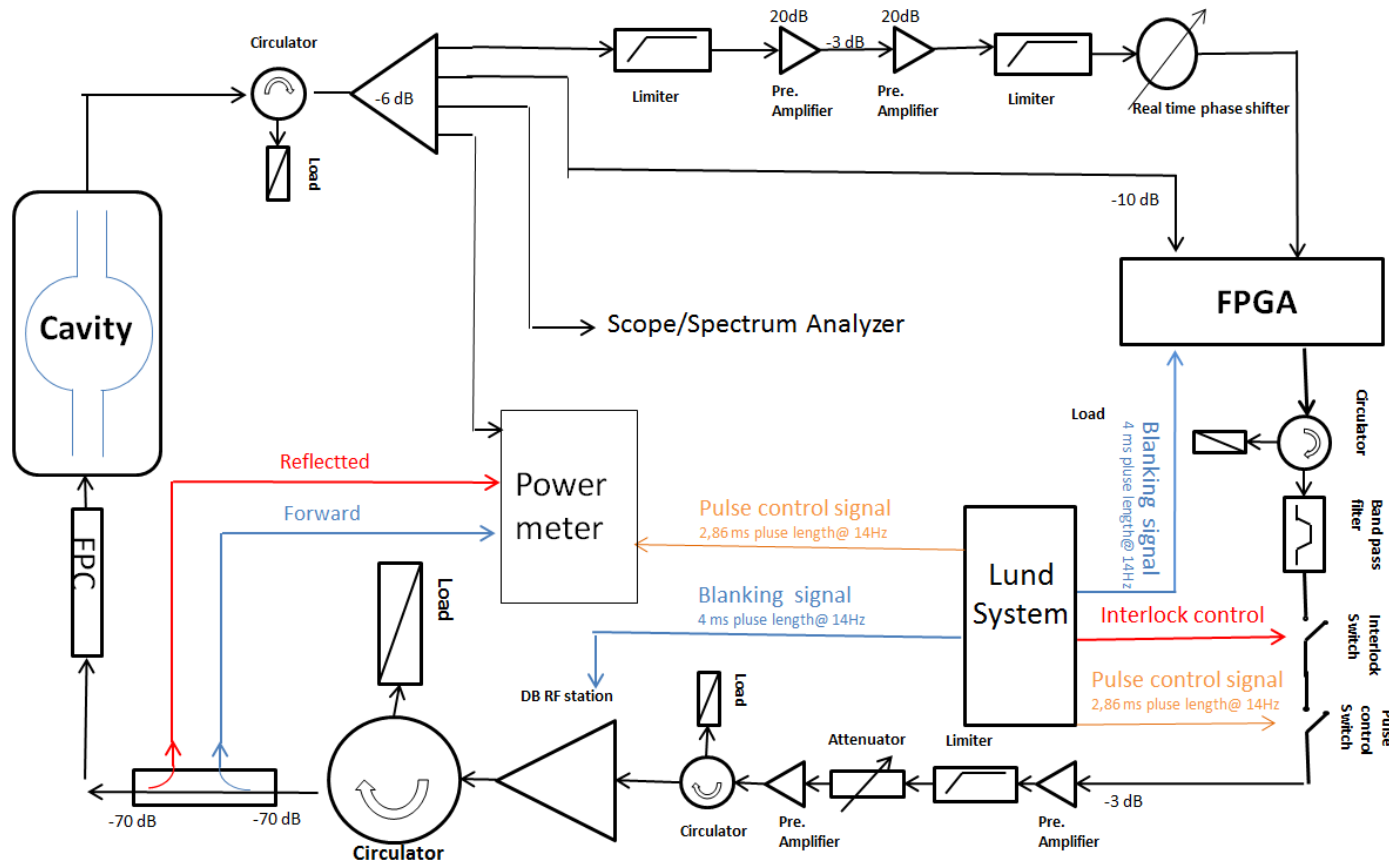

The Self-excited Loop Test Stand (II)



- Combination with a DB RF station which can output up to 400 kW peak power.
- Developed digital phase shifter and gain-controller.
- Introduce interlock system for safety consideration.
- Introduce RF switch in order to manage a pulse operation mode.
- Developed SEL control and data acquisition system in LabView.



RF station



FPGA

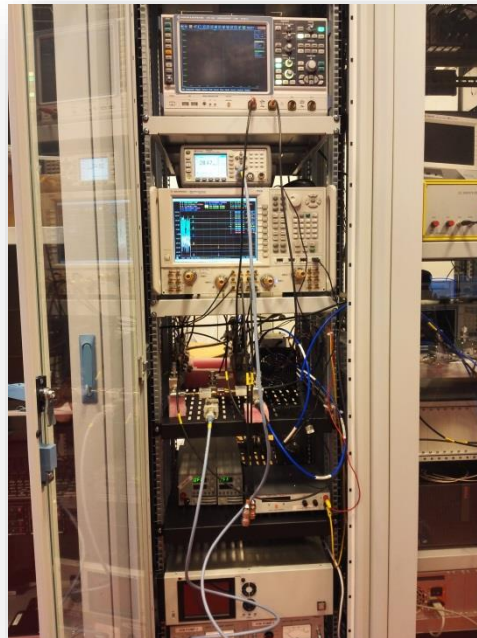

SEL loop installed into a cabinet



Interlock and RF switch

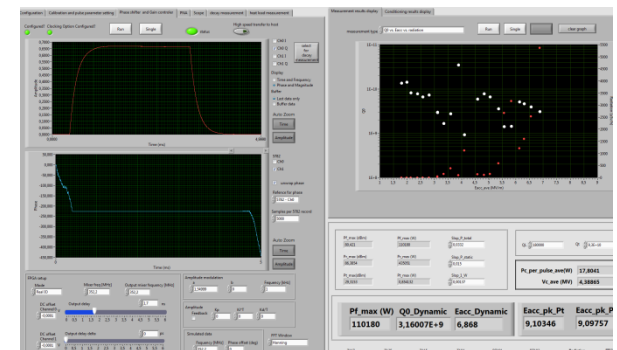

FREIA Labview SEL control system



- The warm and first cold RF processing was done using IPN Orsay's system,
- Followed by the new FREIA conditioning system to verify its performance,
- All processes used a traditional signal generator driven loop,
- The warm RF processing procedure took about 40 hours, while the cold processing took roughly 10 hours,
- During warm conditioning, lots of outgassing occurred through the forward power region of 40-50 kW at short pulses,
- 120 kW forward power was reached with 2.86 ms pulse duration at 14 Hz.

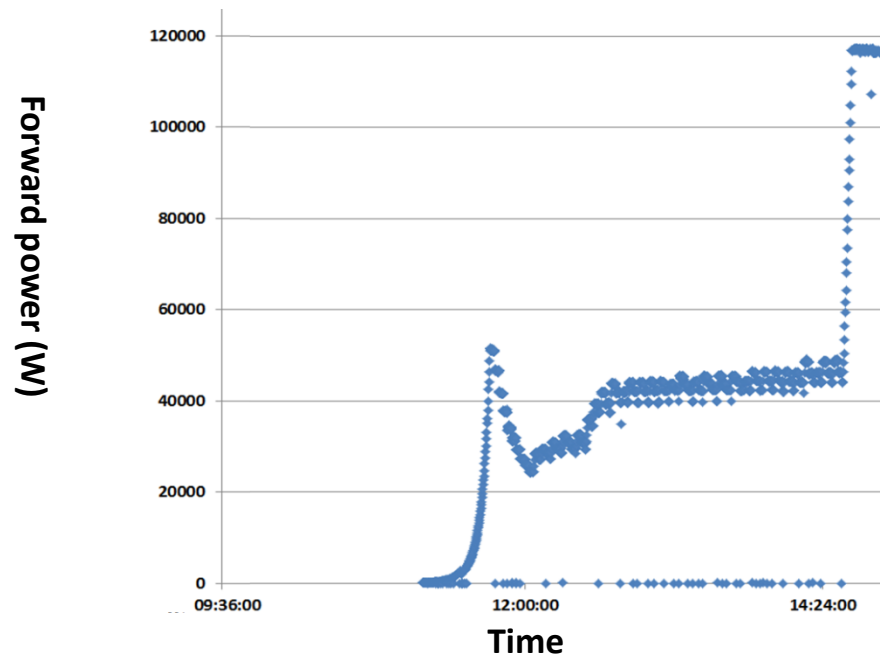

One phase example of FPC warm conditioning

Coupler conditioning (II)



- An automatic conditioning system, which consists of an acquisition system, a control system based on LabView software and feedback was developed at FREIA.
- Key parameters are primarily set.
- The main devices for the RF conditioning process are:
 - ✓ Signal Generator
 - ✓ Power Meter
 - ✓ Vacuum Gauge Controller (VGC)
 - ✓ Cold Cathode Gauges (CCG)
 - ✓ Arc Detector
 - ✓ Electron Detector
 - ✓ Fast RF Interlock Switch
 - ✓ Vacuum Pumping Cart

Parameter	value
Loop control time (s)	1
Pulse repeat rate (Hz)	14
Vacuum upper limit (mbar)	1e-6
Vacuum lower limit (mbar)	5e-7
Initial pulse length (μs)	20
pulse length step	20 μs, 50 μs, 100μs, 200 μs, 500 μs, 1 ms, 1.5 ms, 2 ms, 2.5 ms, 2.86 ms

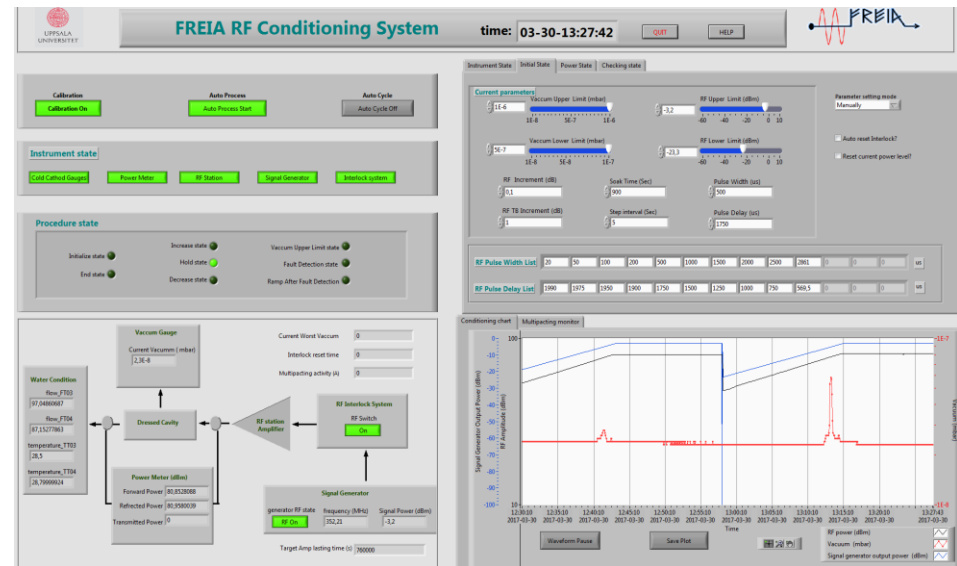
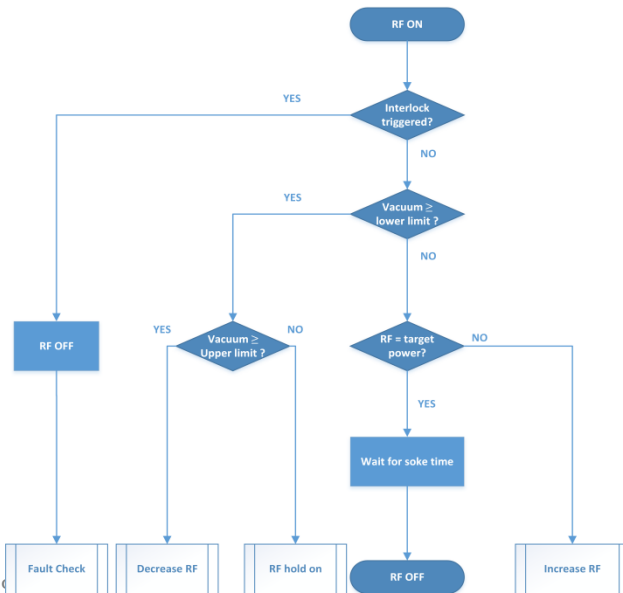

Cool down



- The cavity package in HNOSS cooled down from 205 K to 4 K within 30 minutes,
- From 4K to 2K it took an extra 20 minutes,
- Cavity frequency was checking during cooldown.

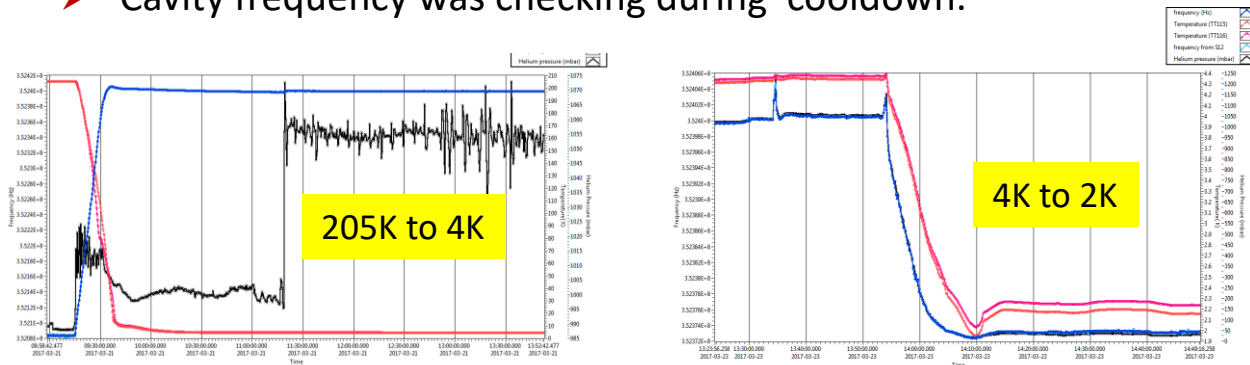

Temp.	Resonance frequency
300 K	351.8939 ± 0.0001 MHz
4 K	352.4004 ± 0.0001 MHz
2 K	352.3725 ± 0.0001 MHz

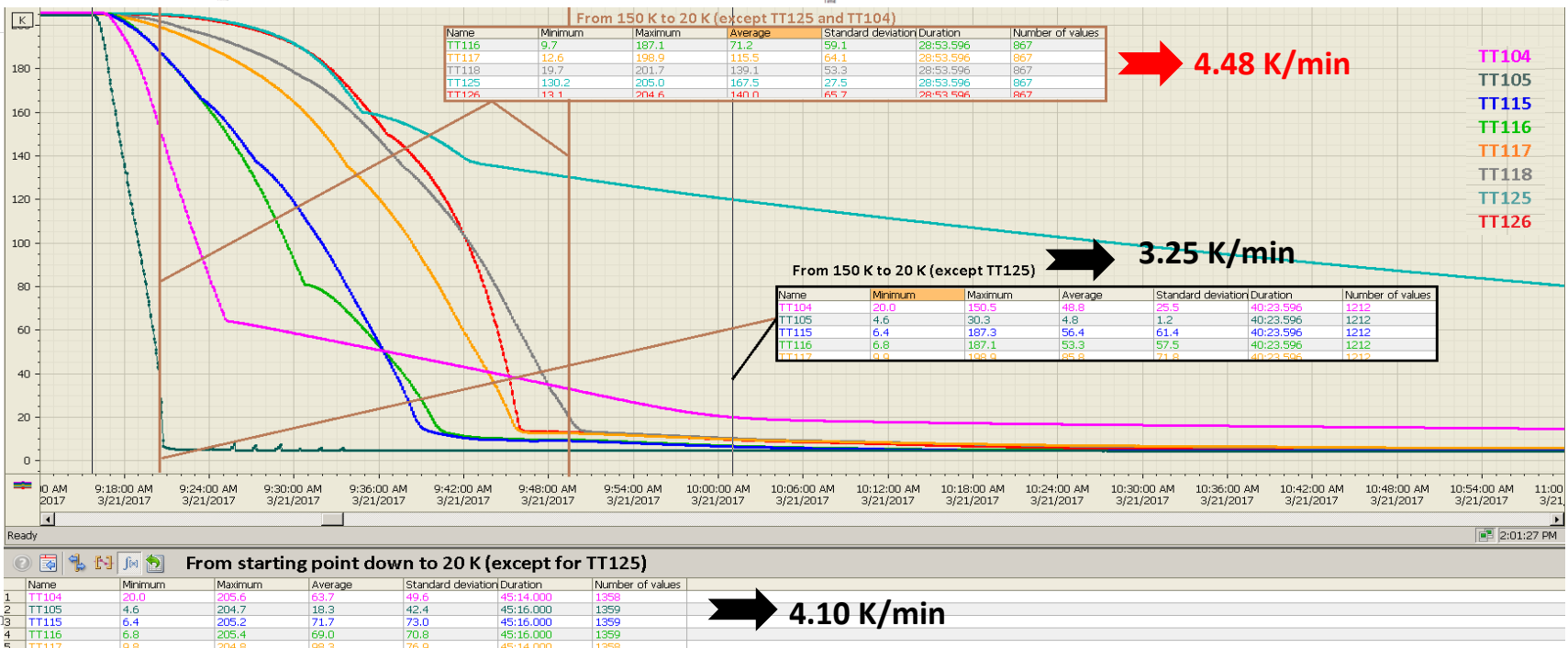

Cavity Package conditioning



- Cavity package conditioning was done by FREIA pulse SEL,
- 2.86 ms pulse with 14Hz repetition rate was used,
- Cavity package conditioning took about 30 hours,
- Three major multipacting regions have been found
 - ✓ Forward power from 22 to 30 kW, peak gradient from 4.5 to 4.8 MV/m.
 - ✓ Forward power form 35 to 48kW, peak gradient from 5.2 to 5.7 MV/m.
 - ✓ Forward power form 67 to 76 kW, peak gradient from 7 to 7.5 MV/m.

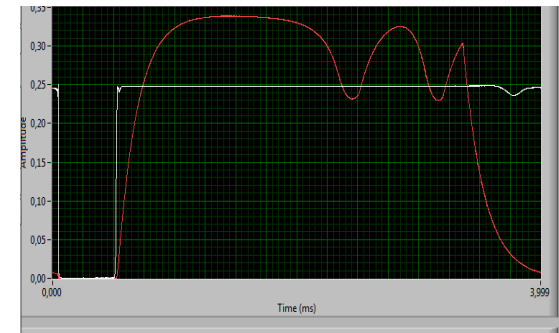

Profile during MP

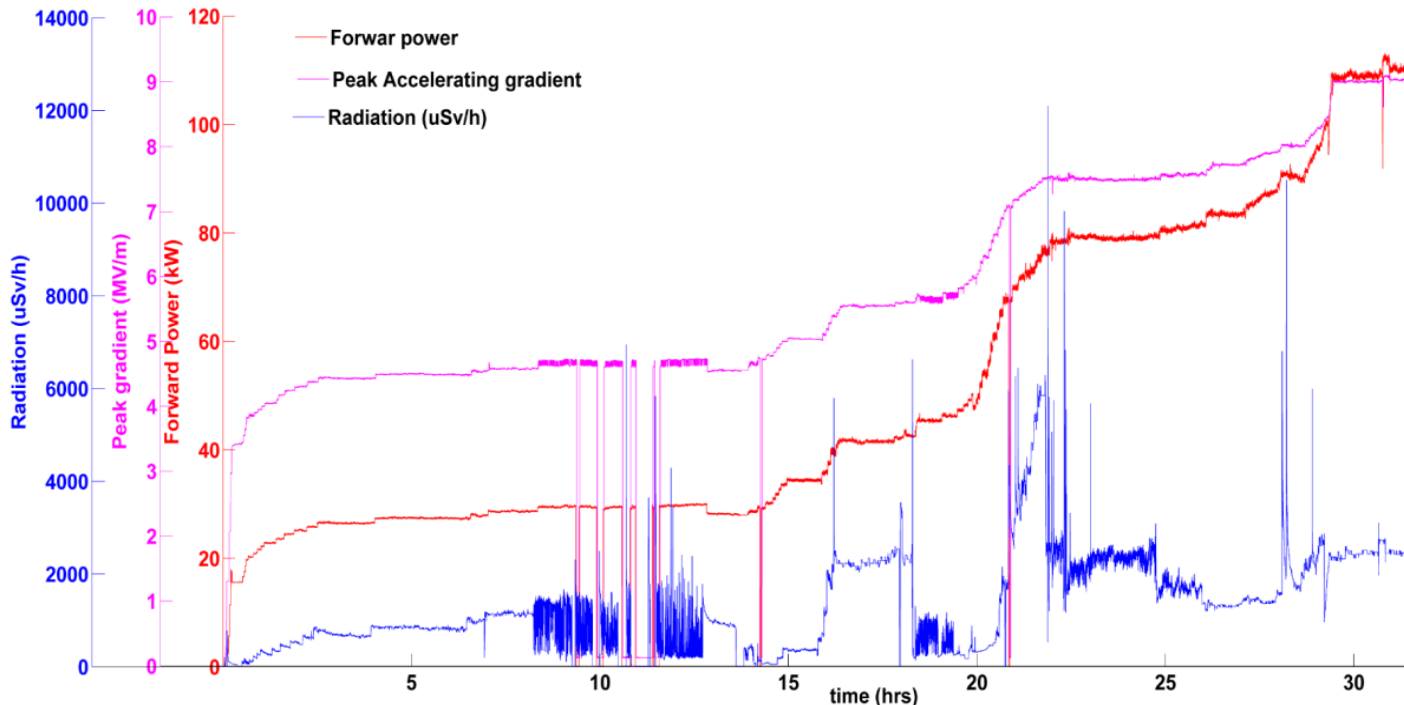

- ✓ The profile of cavity voltage changes.
- ✓ High radiation.
- ✓ Accompany with vacuum spikes.
- ✓ Coupler temperature increase.

- The cooling of the FPC was checked with Cernox sensors TT303 (inlet ScHe), TT305 (outlet ScHe) and a Pt100 sensor (TT147) connected to the midsection of the FPC.

P cavity [mbar]	Eacc_peak [MV/m]	TT303 [K]	TT147 [K]	TT305 [K]
20	0	14	39.5	291
20	9	9.8	41.6	278

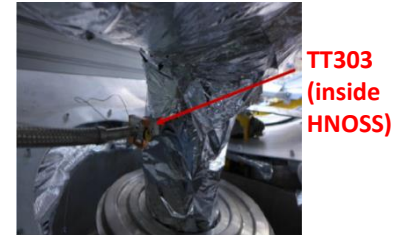
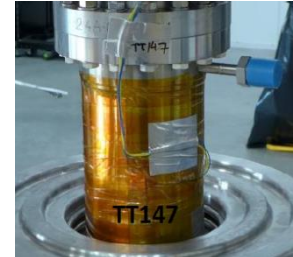

- At **20 mbar** operating pressure, the static heat loads for Romea with TT147 at ca 41 K amount to ca. **6.6 W**

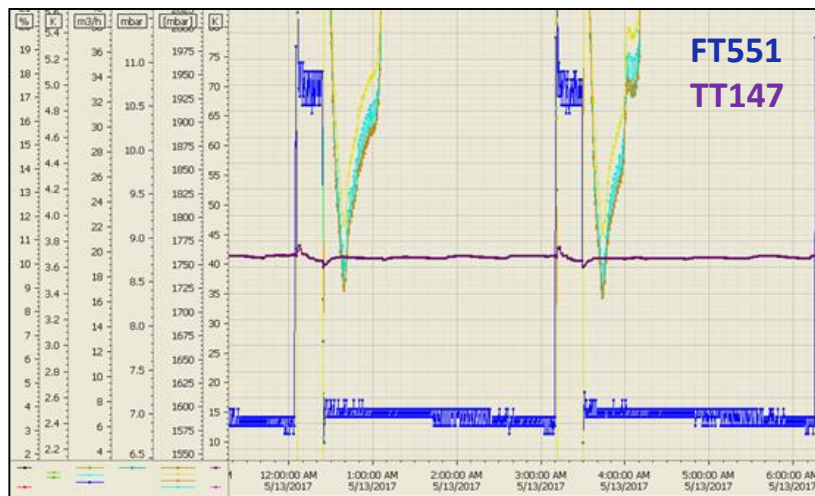

Identified four (4) regions depending on level

FT551 [m3/h]	Std dev [m3/h]	LT101	
		min [%]	max [%]
7.12	0.34	76	80
6.81	0.31	72	76
6.54	0.33	69	72
6.11	0.33	60	69

Note: tests where TT147 was varied between 30K and 90K give an extra heat load of only 1W at 20 mbar.

- Calorimetric measurement of Q_0
 - ✓ The level in the 2K tank was kept between 60% and 80%
 - ✓ Apply a known amount of resistive heat to the helium
 - ✓ Close inlet and outlet valves of the cryostat
 - ✓ Record the pressure as a function of time for three (3) minutes

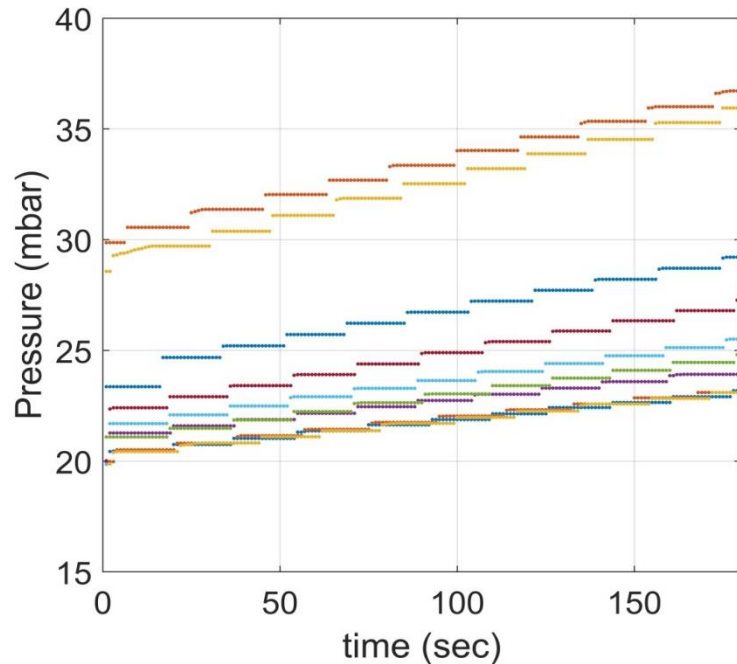
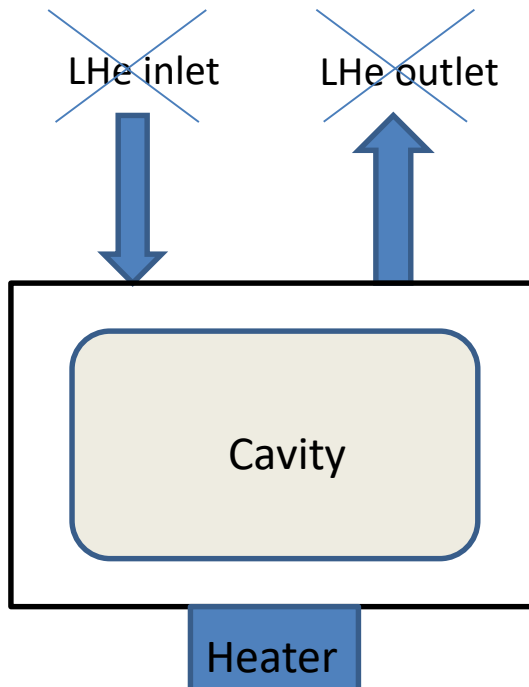

Pressure curve vs Applied Power

Q₀ measurement (II)



- Calorimetric measurement of Q₀ cont.
 - ✓ Build the calibration curve: the rate of pressure rise vs. heat
 - ✓ Load apply RF to the cavity and the system was left to stabilise only in pressure, record the pressure rise
 - ✓ Calculate the dynamic RF load using the calibration curve

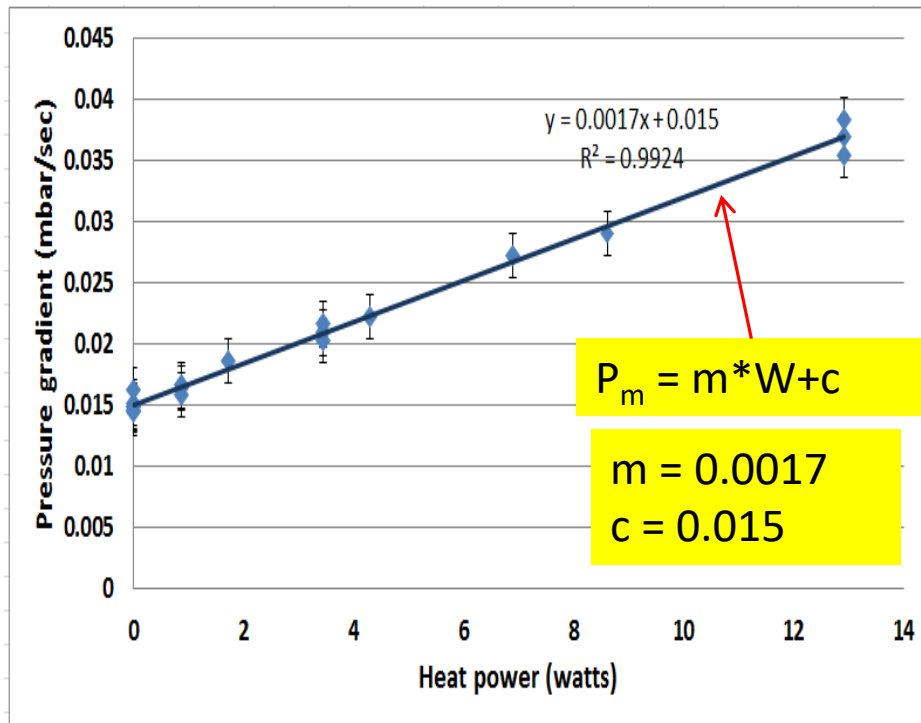

Eacc_paek (MV/m)	pressure rise slop	dynamic RF load (W)
2,004499	0,0152	0,117647
2,515368	0,0153	0,176471
2,699868	0,0156	0,352941
3,02766	0,0158	0,470588
3,287095	0,0161	0,647059
3,591016	0,0162	0,705882
4,008444	0,0187	2,176471
4,317015	0,0227	4,529412
5,321938	0,0359	12,29412
5,966339	0,0191	2,411765
6,301396	0,0185	2,058824
6,589388	0,0195	2,647059
7,012012	0,0245	5,588235
7,360766	0,0413	15,47059
7,697375	0,0432	16,58824
8,07178	0,0237	5,117647
8,31318	0,0252	6
8,659001	0,028	7,647059
9,097229	0,0332	10,70588

Dissipate power calibration curve

Double Spoke Cavity Performance

(Romea, 2017)



➤ Test of cavity package.

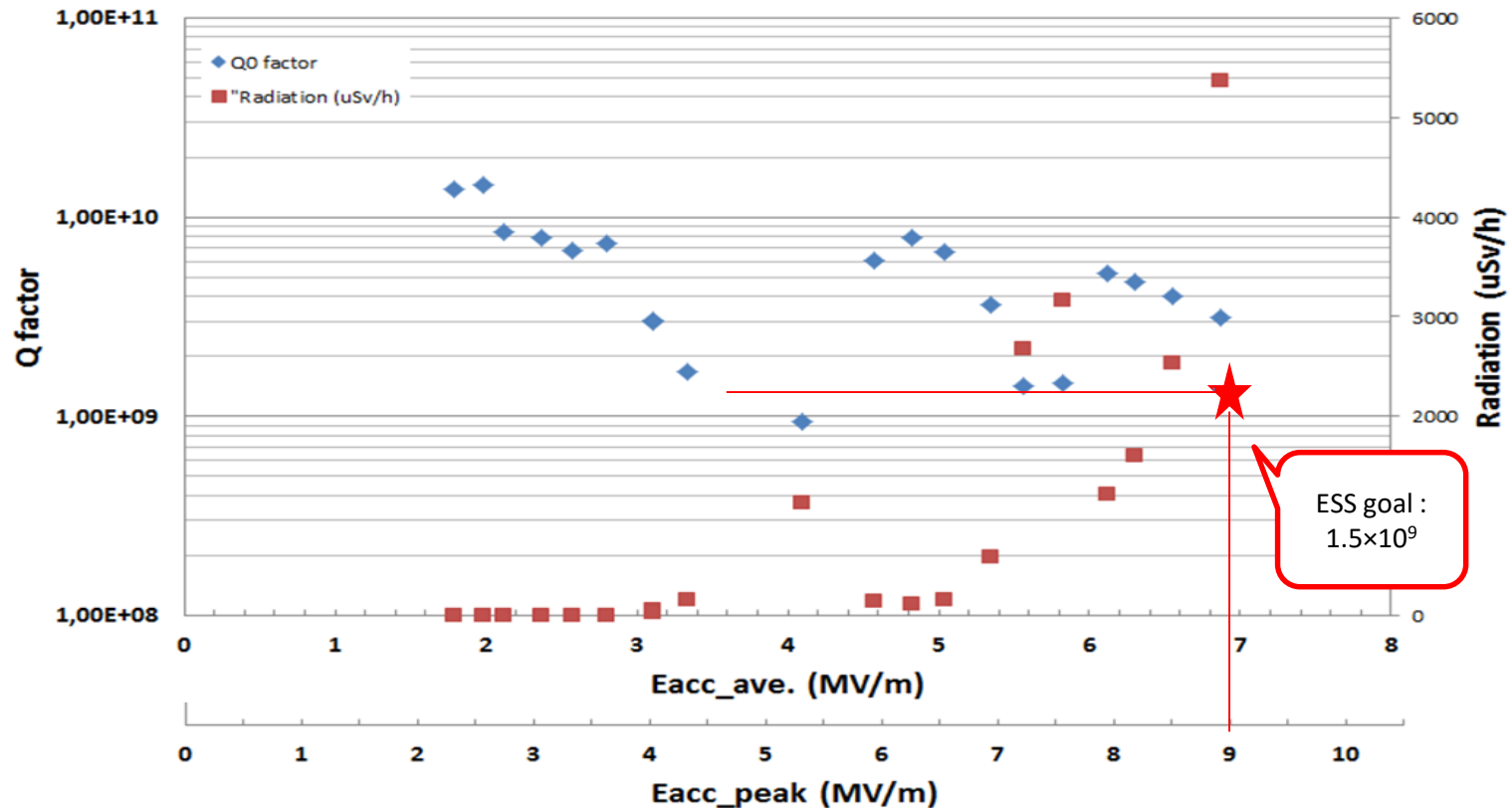

- ✓ Low-field Q_0 factor of 1.6×10^{10} @ 2 K
- ✓ Q factor of 3.6×10^9 @ Eacc_peak=9MV/m
- ✓ Several multipacting regions were found

Cavity Voltage Rising Time

- Measured with SEL and pure square pulse input.

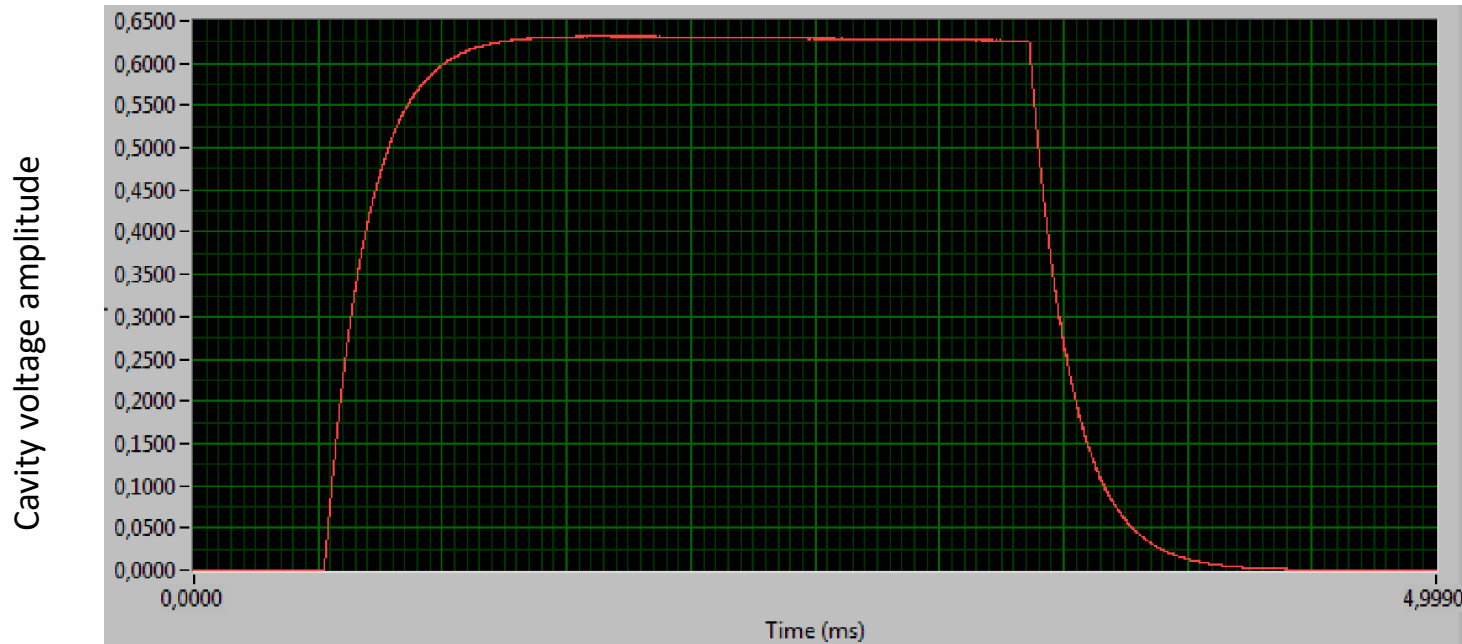

- ✓ Cavity voltage ramp up from noise to flat top takes about 800us.
 - ✓ The two steps pulse shape is then necessary.
- ✓ Filling time (67% of flat top) is about 200us.



- Monitoring and manipulating the complex signal from cavity during the pulse, dynamic Lorentz force detuning at different gradient were studied.

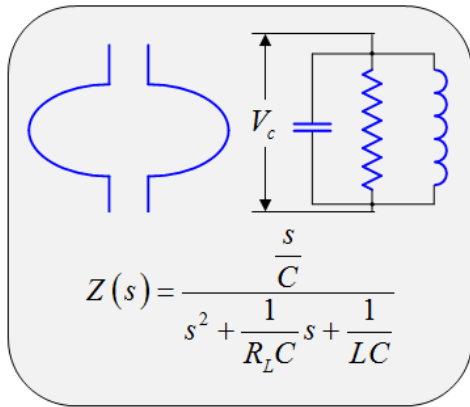

$$\frac{d\vec{V}_c}{dt} + (\omega_{1/2} - j\Delta\omega)\vec{V}_c = \omega_{1/2}R_L\vec{I}$$



$$\begin{cases} r\phi' - r\Delta\omega = \omega_{1/2}\rho \sin(\theta - \phi) \\ r' + r\omega_{1/2} = \omega_{1/2}\rho \cos(\theta - \phi) \end{cases}$$

state space equation

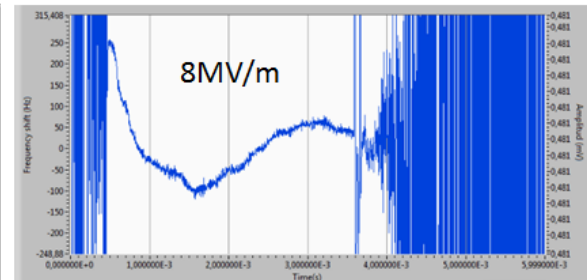
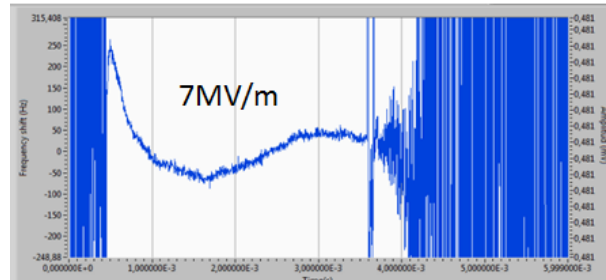
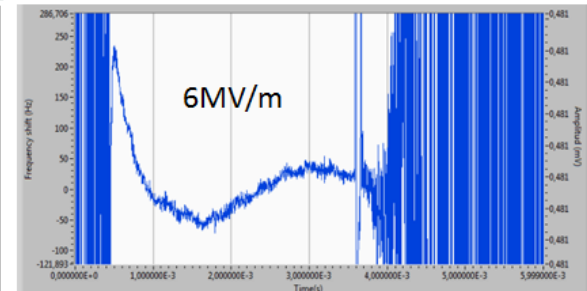
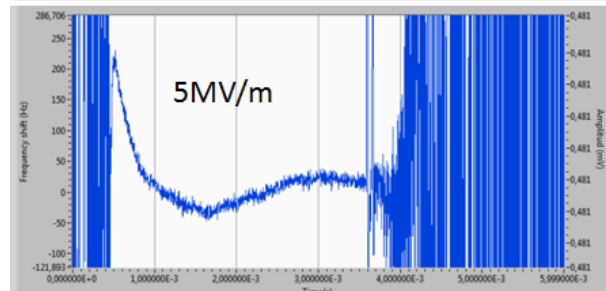
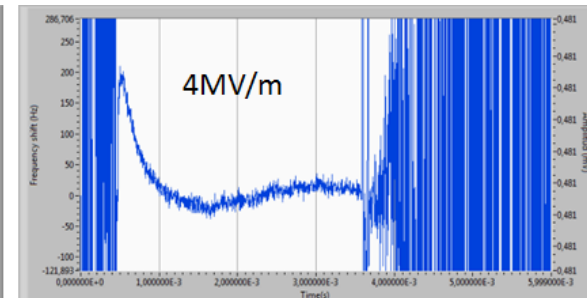
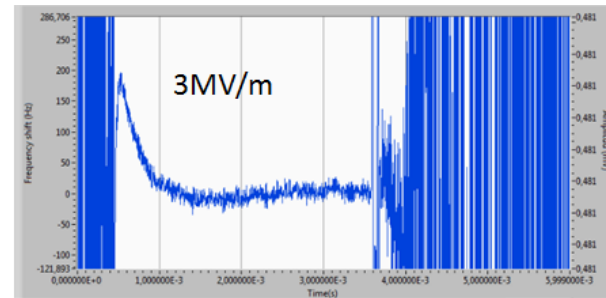



- Developed an FPGA-based LabView program for dynamic Lorentz force detuning.
- Frequency shift at peak accelerating gradient 9MV/m@ 2.86 ms pulse length is about 400Hz.
- A Loaded Q value of 1.8×10^5 from state space equation calculation is consistent with the VNA measurement.

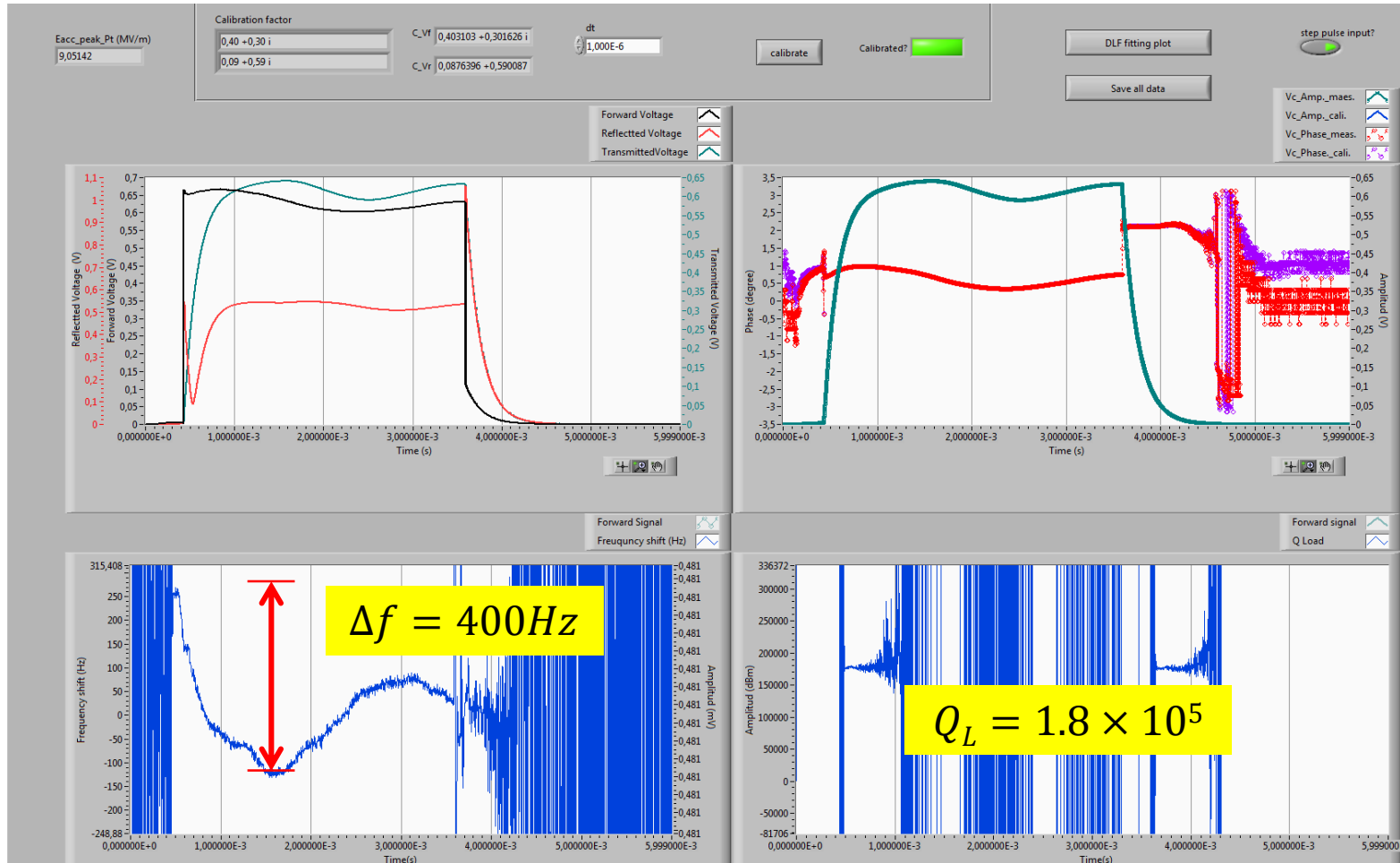

- Stimulate the cavity by amplitude modulation .
- By sweeping the modulation frequency up to 800 Hz, the fit of mechanical modes was studied.
- Slow tuner is in fixed position .

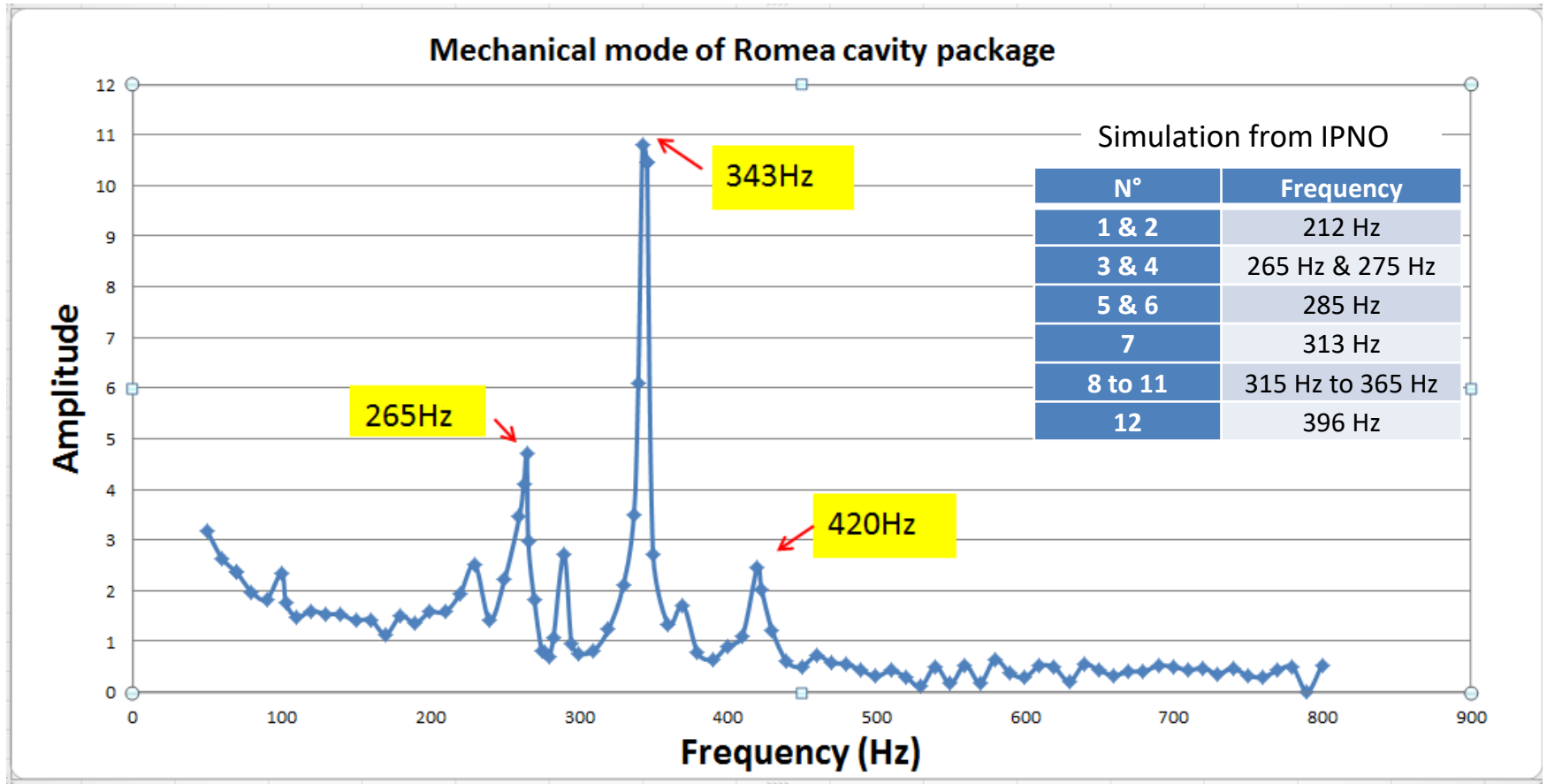

- By closing both the inlet and outlet of the cryostat, checking the cavity frequency shift as a function of helium pressure from 20 to 40 mbar.

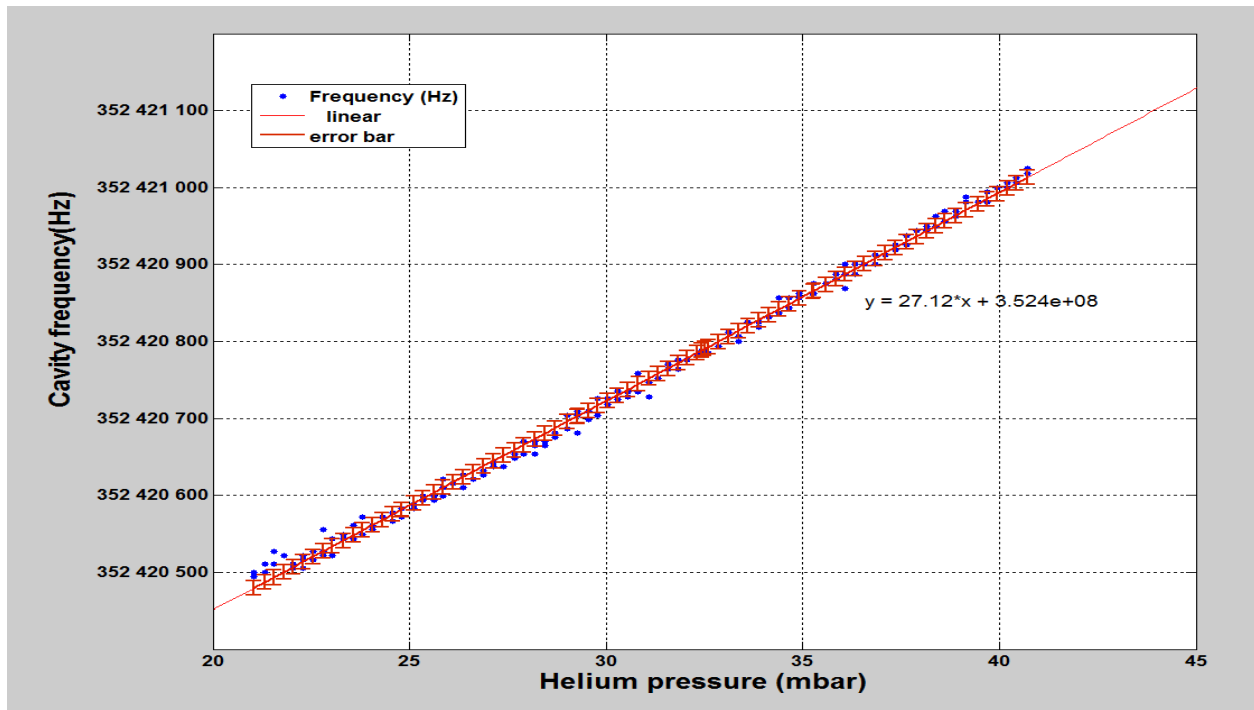

pressure sensitivity = +27.1 Hz/mbar

- This result is consistent with the 28 kHz frequency shift measured during cool down from 4.2 K (~1030mbar) to 2 K (~20mbar).

- Slow tuner is controlled by Lund system.

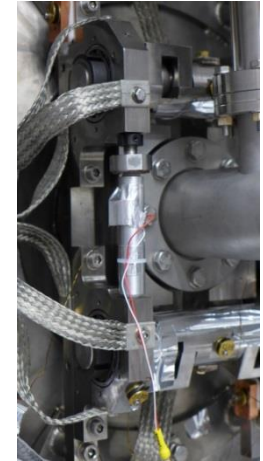
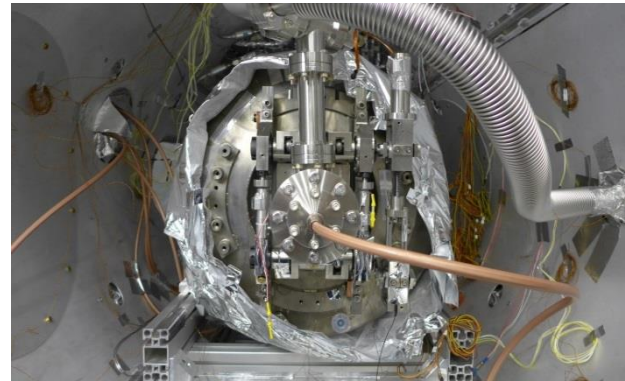
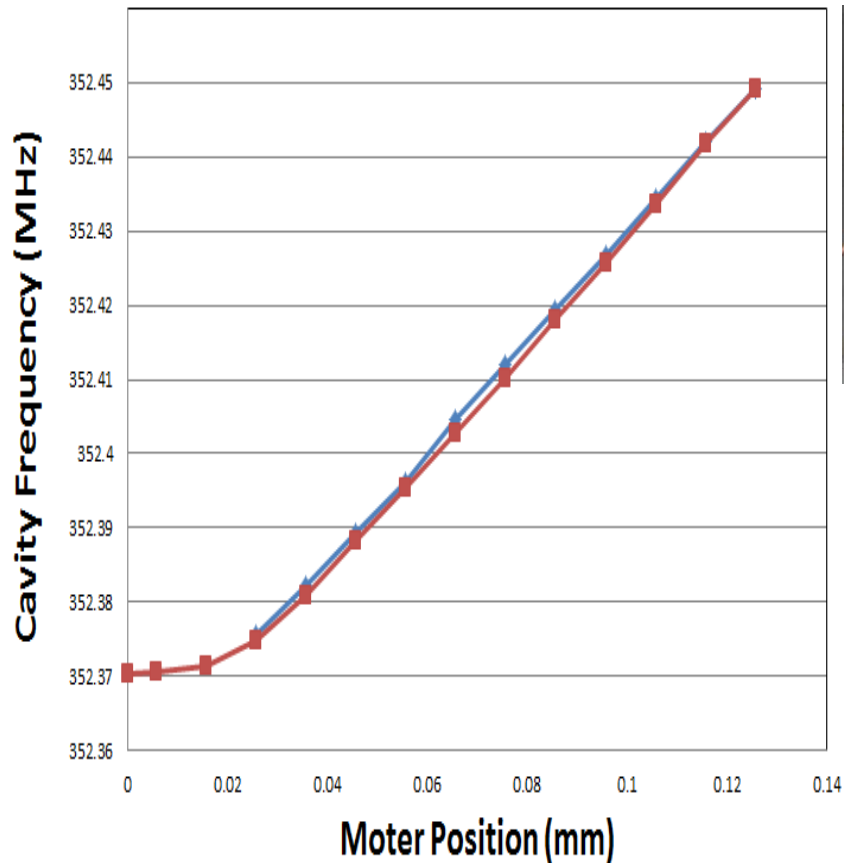

—▲ 1st run pulling motor
—■ 2nd_run releasing motor

- Tuning sensitivity:
150 kHz/mm @ 2K

- Test of Spoke Cryomodule and high-beta Elliptical cavity this year.
- Verify
 - ✓ valve box ability and performance.
 - ✓ ability and performance of the two individual cavities in the cryomodule
 - ✓ simultaneous operation of both cavities in the cryomodule in combination with the LLRF and high power RF system
 - ✓ performance of the magnetic shield
 - ✓ ability and performance of the cryomodule including cryogenic heat load, cooling of cavity and FPC.

➤ Conclusions

- ✓ A test stand for high power test based on a self-excited loop was developed at FREIA.
- ✓ The first ESS spoke cavity package has been tested with the tetrode based RF system.
- ✓ System is ready for Spoke Cryomodule.