

# MTR Meeting

## Work Package 4: Innovation of key neutronic technologies: Detectors and Moderators

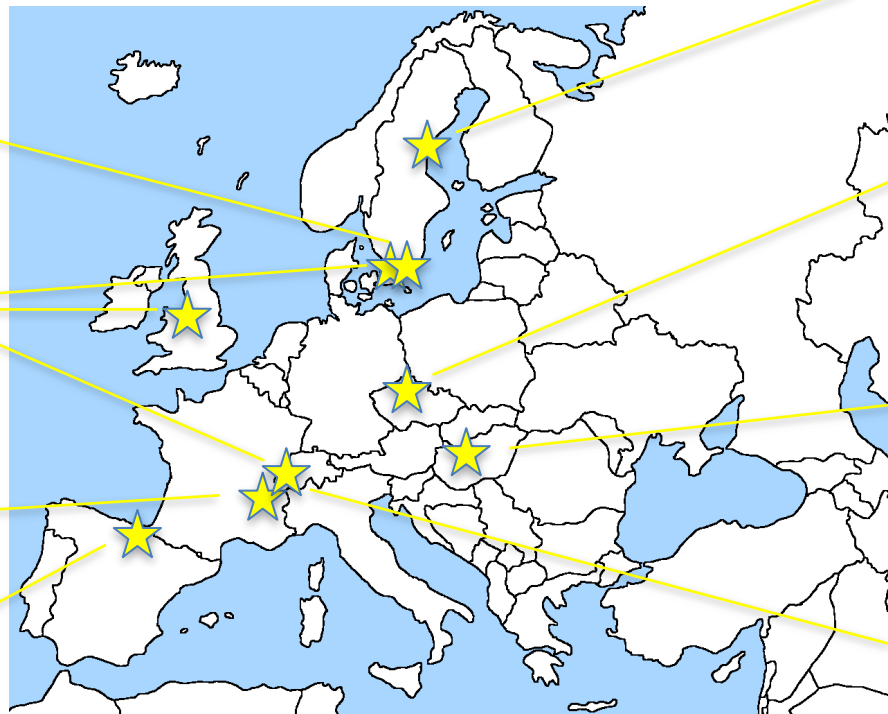
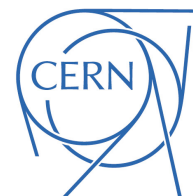
Richard Hall-Wilton, Work Package Manager



# WP4 Partners

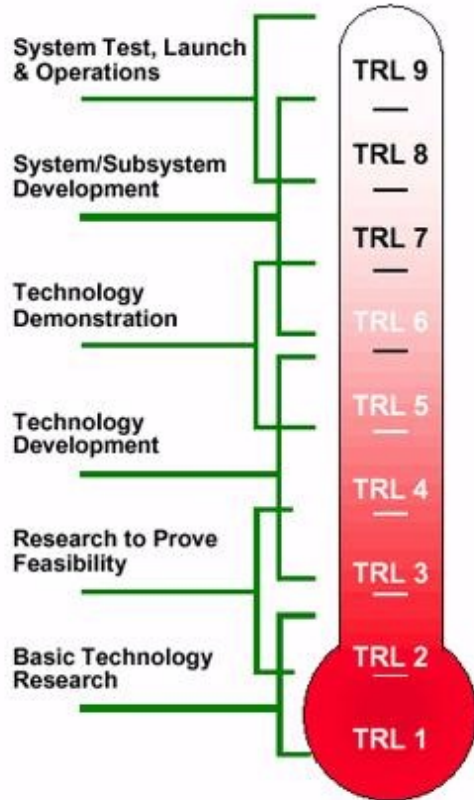


EUROPEAN  
SPALLATION  
SOURCE

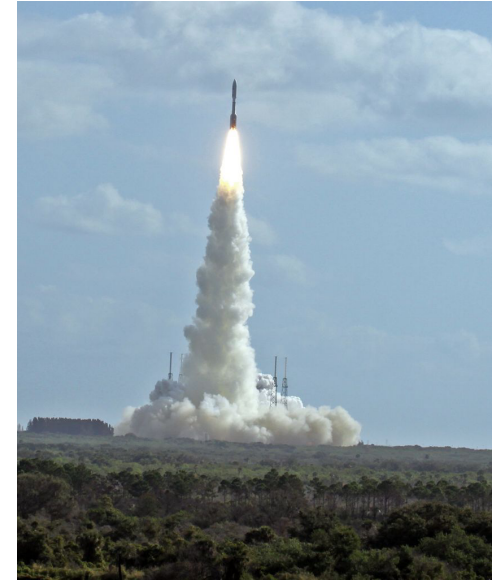


- ESS-Bilbao joined WP4 recently



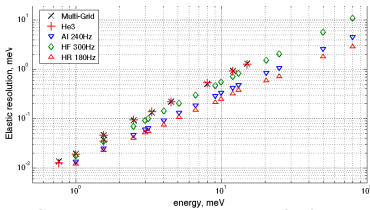
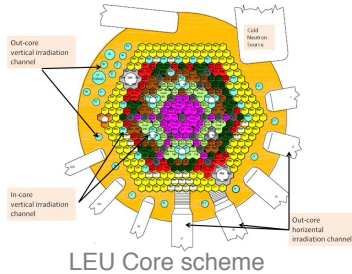


- Task 4 is a technical task focussed on challenges in neutronic technologies
- It is about validating and realising these technologies
- It is about taking novel technologies selected for ESS from “Technological Readiness Level” 3-5 to 8-9
- Aim: helping a smooth start for ESS scientific output

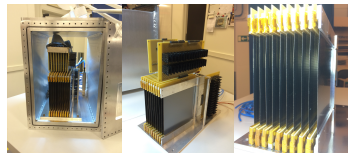


# Overview of WP

- WP4 is a technical work package focussed on challenges in neutronic technologies
- WP4 aim for the disruptive innovation in terms of the development and integration of neutron detectors and moderators currently needed directly and indirectly for 9 current and future ESS Instruments.
- Technological risk reduction for the delivery of the ESS project
- By enhancing moderator and detector capability, maximise the early science impact of ESS
- Fundamentally in-kind and collaborative tasks, relying on the expertise of partner institutes involved

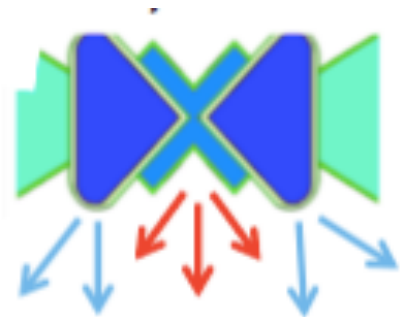


Instrument energy resolution using MG compared to He3

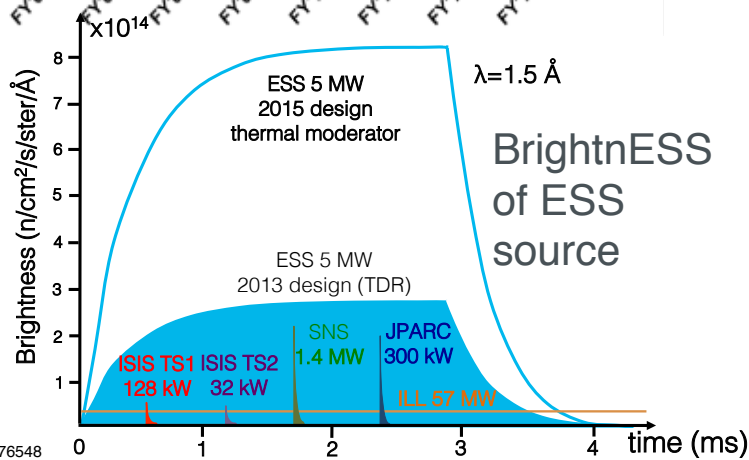
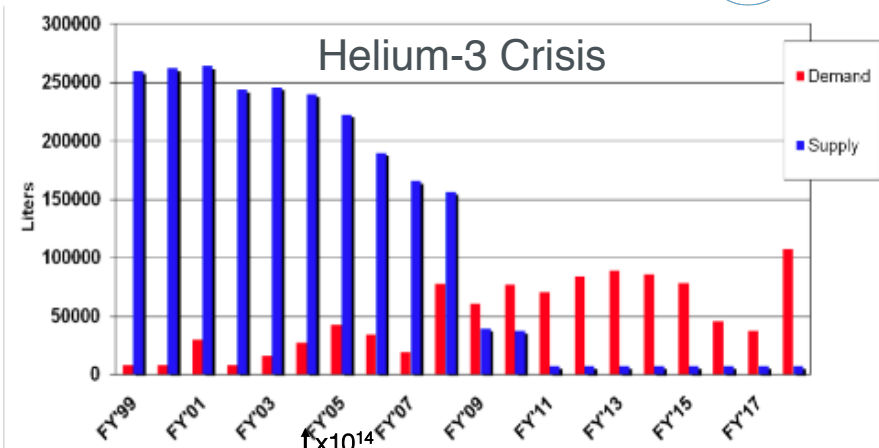


MB 2015 prototype built and tested in BNC

# The Technical Challenge



Engineering Low Dimensional Moderators



## Instrument Design

## Implications for Detectors

Smaller samples

Better Resolution  
(position and time)  
Channel count

Task 4.1  
“The Resolution Challenge”

Higher flux, shorter experiments

Rate capability and data volume

Task 4.2:  
“The Intensity Frontier”

More detailed studies

Lower background, lower S:B  
Larger dynamic range

Task 4.4: “Detector  
Realisation”

Multiple methods on 1 instrument  
Larger solid angle coverage

Larger area coverage  
Lower cost of detectors

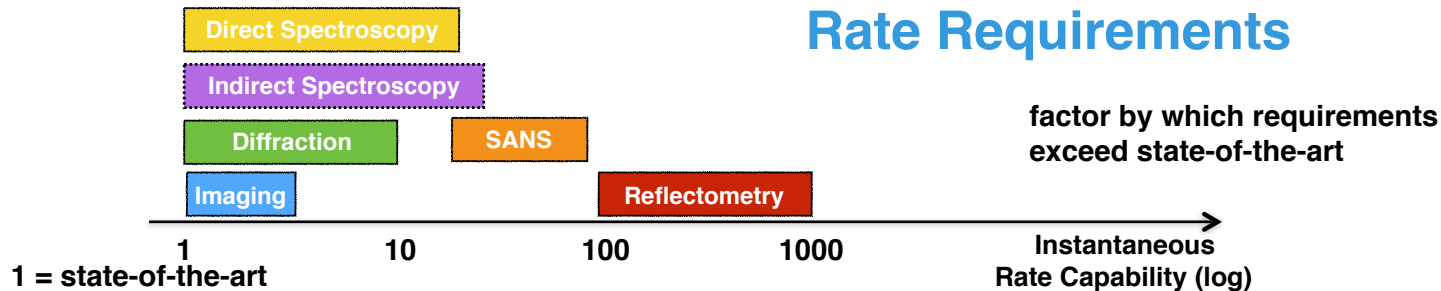
Task 4.3:  
“Realising Large Area  
Detectors”

## Developments required for detectors for ESS

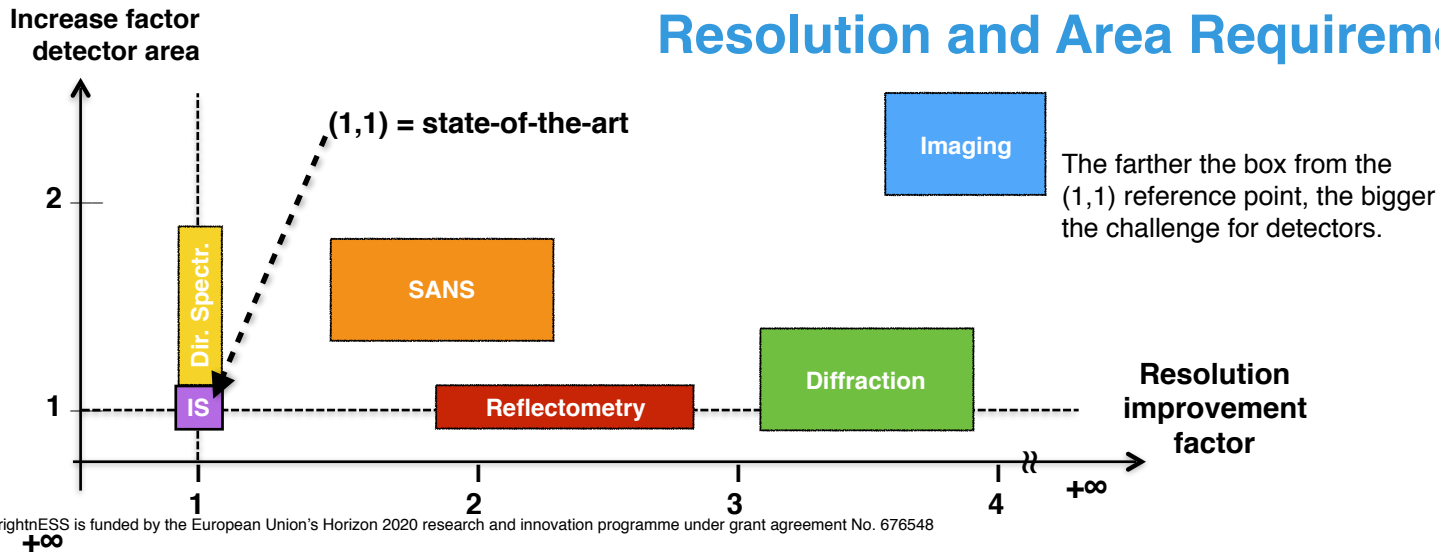


# Requirements Challenge for Detectors for ESS: beyond detector present state-of-the-art

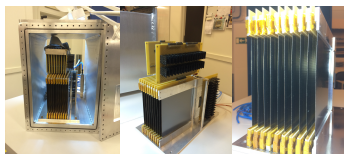
## Rate Requirements



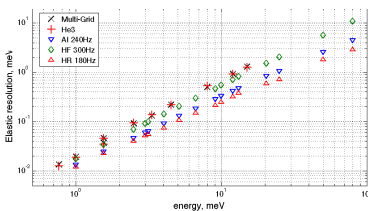
## Resolution and Area Requirements



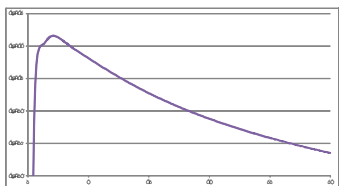
# Overview of WP



MB 2015 prototype built and tested in BNC

















Instrument energy resolution using MG compared to He3



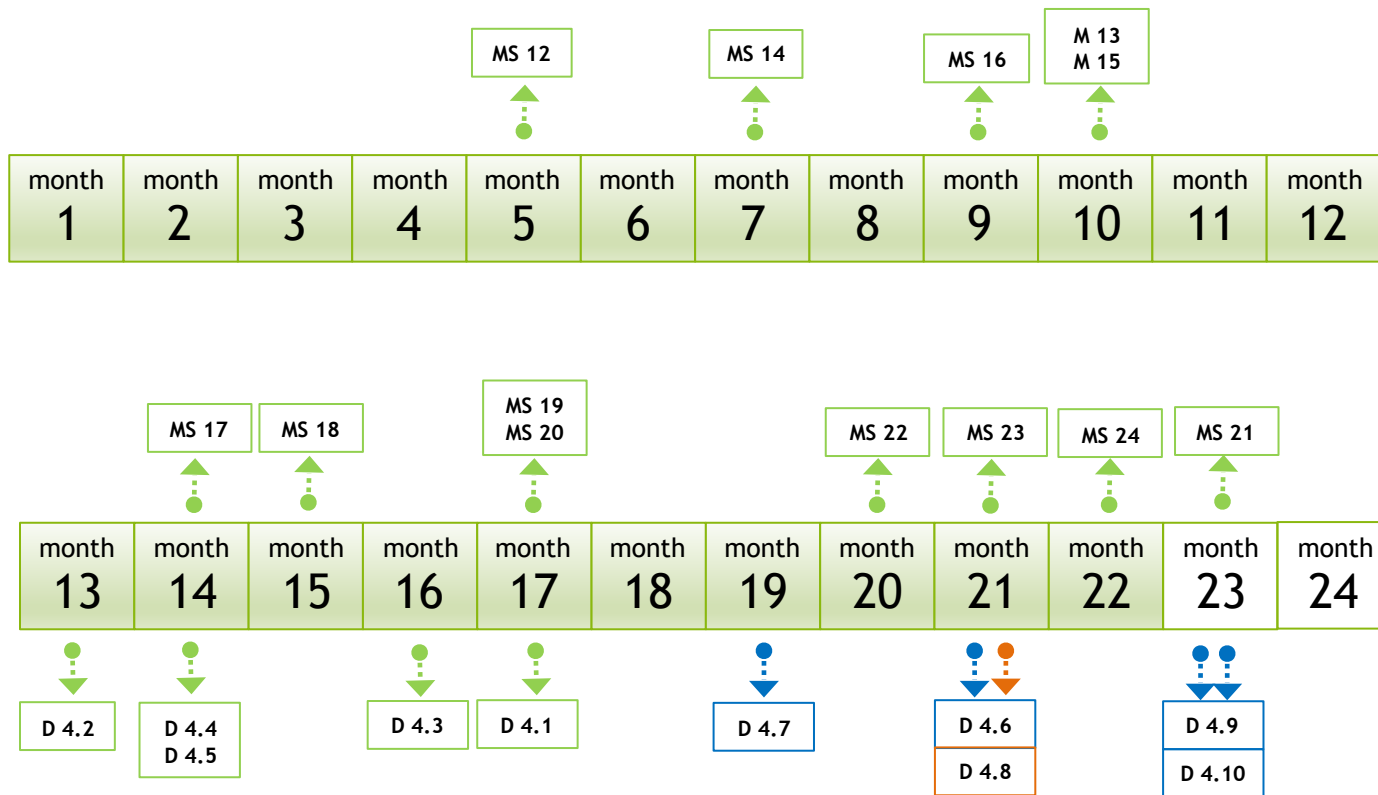
Measured Cold Neutron Source Brilliance

- WP4 aim for the disruptive innovation in terms of the development and integration of neutron detectors and moderators currently needed directly and indirectly for 9 current and future ESS Instruments.
- Timeline: September 2015 – August 2017
- Purpose of Tasks:
  - Task 4.1: The Resolution Challenge
  - Task 4.2: The Intensity Frontier
  - Task 4.3: Realising Large Area Detectors
  - Task 4.4: Detector Realisation
  - Task 4.5: Moderator Testing and Beamline Development



- Work Package Manager: Richard Hall-Wilton
- Deputy Work Package Manager: Judith Freitas-Ramos
- Purpose of Tasks:
  - Task 4.1: The Resolution Challenge. Task leader: Michael Lupberger (CERN)     EUROPEAN SPALLATION SOURCE
  - Task 4.2: The Intensity Frontier. Task leader: Francesco Piscitelli (ESS)    EUROPEAN SPALLATION SOURCE  ESS Bilbao
  - Task 4.3: Realising Large Area Detectors. Task Leader: Anton Khaplanov (ESS)  EUROPEAN SPALLATION SOURCE  NEUTRONS FOR SCIENCE  EUROPEAN SPALLATION SOURCE
  - Task 4.4: Detector Realisation. Task Leader: Hanno Perrey (Lund U)   EUROPEAN SPALLATION SOURCE
  - Task 4.5: Moderator Testing and Beamline Development. Task Leader: Laszlo Rosta (Wigner) 

# Timeline \*



10 deliverables

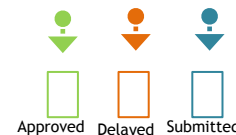
5 approved

4 submitted

1 delayed

13 milestones

13 achieved



\* according to amended Grant Agreement; timeline shows submission dates (covers M1 - M22)



# Status of WP4 deliverables

Del. Rel. N <sup>o</sup>	Title	Due date (months)	Est. Del. Date	Receipt Date	Approval Date	Status
D4.1	Integration plan for readout	10	30/Jun/16	17/Jan/17	10/Apr/17	Approved
D4.10	Test for technology demonstrator	23	31/Jul/17			Pending Submitted
D4.11	Standardised test procedures for performance of detectors for early ESS instruments	33	31/May/18			Pending
D4.12	Reflectometry detector	34	30/Jun/18			Pending
D4.13	Module for NMX detector	35	31/Jul/18			Pending
D4.14	Large area detector for spectrometry	36	31/Aug/18			Pending
D4.15	Final verification of BRR moderator	36	31/Aug/18			Pending
D4.2	Counting rate capability	11	31/Jul/16	13/Sep/16	13/Oct/16	Approved
D4.3	Natural and enriched Gadolinium converters design	12	31/Aug/16	02/Dec/16	08/Dec/16	Approved
D4.4	Report on the engineering design of the BRR low dimensional moderator	12	31/Aug/16	05/Oct/16	13/Oct/16	Approved
D4.5	Simulation and Generic multi-grid design	13	30/Sep/16	05/Oct/16	14/Oct/16	Approved
D4.6	Detector characterisation	19	31/Mar/17	22/May/17		Submitted
D4.7	Report on the conception design of the ESS and the BRR test beam-line	19	31/Mar/17			draft Submitted
D4.8	Monte Carlo simulations for early ESS instruments	21	31/May/17			Pending
D4.9	Detector electronics chain	22	30/Jun/17	11/Jul/17		Submitted

- 9 deliverables complete so far
- Deliverables up-to-date except D4.8
- D4.8 a couple of months late due to paternity leave and holidays. It is approaching completion
- 6 deliverables remaining

## Status of WP4 milestones

Del. Rel. No.	Title	Due date	Est. Del. Date	Status
12	Improvement of the multi-face detectors (MSTGC and no-amplification) to create prototypes	01/02/2016	17/01/2016	completed
14	Optimisation for bispectral instrument.	01/04/2016	23/03/2016	completed
15	General design for multi-grid	01/06/2016	01/06/2016	completed
16	Improvement of the counting rate capability.	01/06/2016	27/05/2016	completed
13	Modelling and experimental verification of the new moderator concept	01/07/2016	30/06/2016	completed
17	Detailed plan for detector system integration.	01/07/2016	06/10/2016	completed
18	Optimised design for NMX	01/11/2016	15/11/2016	completed
19	Instrument focused design	01/02/2017	30/01/2017	completed
20	Characterisations of the demonstrators	01/02/2017	26/01/2017	completed
21	Verification of ESPI setup.	01/05/2017	12/07/2017	completed
22	Definition of detector electronics chain	01/05/2017	28/04/2017	completed
23	Technology demonstrator	01/06/2017	30/05/2017	completed
24	Natural and enriched Gadolinium convertors possibilities and market strategy	01/09/2017	26/06/2017	completed
25	Evaluation of possible ultra-high resolution detector	01/02/2018		pending
26	Verification of prototype components (BRR & ESS)	01/02/2018		pending
27	Simulations for early ESS instruments and standardised procedures	01/04/2018		pending
28	Verification of moderator and ESPI components	01/05/2018		pending
29	1st Detector construction	01/05/2018		pending
30	2nd Detector construction	01/06/2018		pending
31	Module of detector ready for deployment	01/06/2018		pending

- 13 milestones complete so far
- 7 milestones remaining

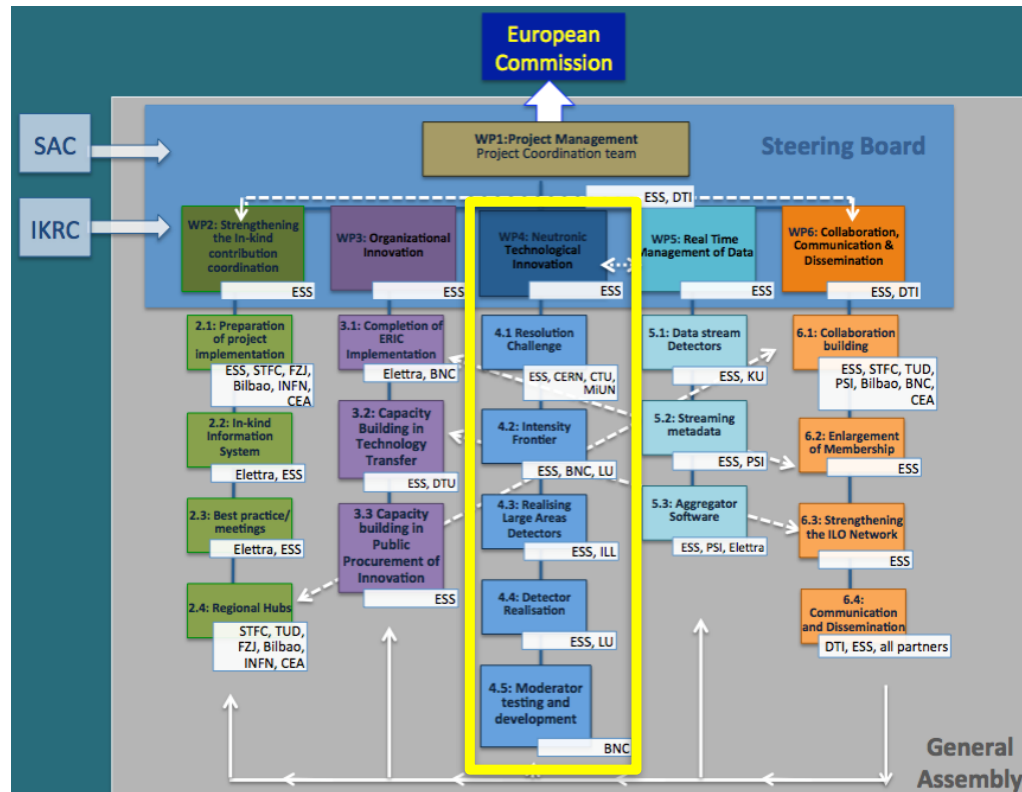
## Status of KPIs from WP4

KPI	Planned number (project)	Actual number (@M18) (Detectors)
Number of publications on neutronic technologies	7	15
Number of participation in conferences related to neutronic technologies	23 (3 Data + 20 Detectors)	32
Number of developed open source software packages	6 (2 Data + 4 Detectors)	3
Number of successful simulations	6	9

# WP4 organisation

WP4 members:

Name	Role	Partners
Richard Hall-Wilton (ESS)	Work Package Leader	
Michael Lupberger (CERN)	Leader of Task 4.1	ESS, CERN, CTU, MiUN
Francesco Piscitelli (ESS)	Leader of Task 4.2	ESS, BNC, LU
Anton Khaplanov (ESS)	Leader of Task 4.3	ESS, ILL
Hanno Perrey (LU)	Leader of Task 4.4	ESS, LU
Laszlo Rosta (BNC)	Leader of Task 4.5	BNC

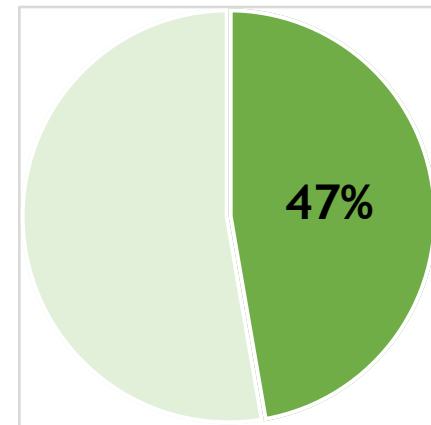


# Activities and results not (yet) achieved

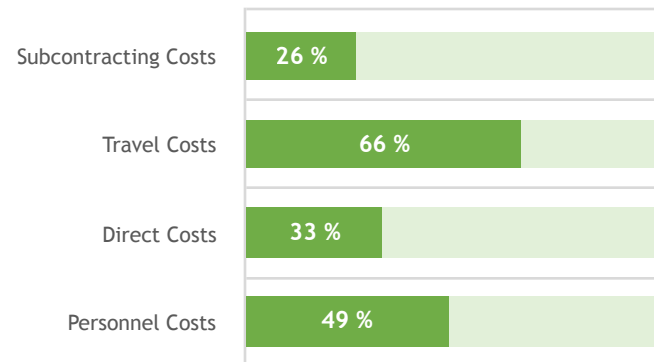
- All activities on track
- Deliverables: *D4.8 Monte-Carlo Simulation for early instruments (Task 4.4). Work complete, draft text exists, needs formatting and editing: imminent*
- Delayed due to paternity leave and summer period
  
- In a good state at this point ... all work up and running ... all partners at full speed
- Impact on risk reduction for ESS project on neutron detectors for instruments and low dimensional moderators is being felt
- Provision of neutron detectors for instruments has gone from high technical risk to a normal technical risk as a result of work undertaken in past years: This is a very significant impact of brightness

# Costs

- Spent 47% of total at 60% through the project
- Reason for underspend: recruitment at most partners delayed from the start of the project (back weighted costs)
- Also: subcontracted costs scheduled later in project
- Discussion has taken place with all underspent partners. Action plan developed in all cases.
- Will continue to monitor costs towards end of project



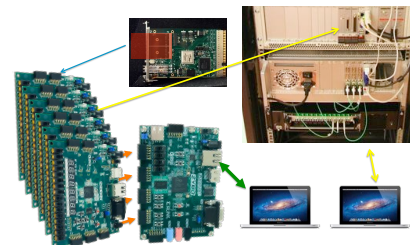
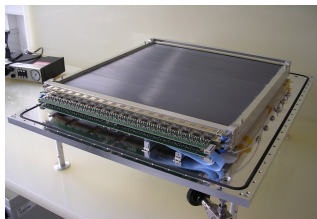
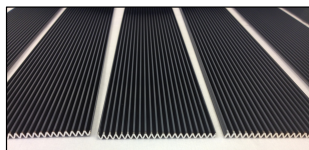
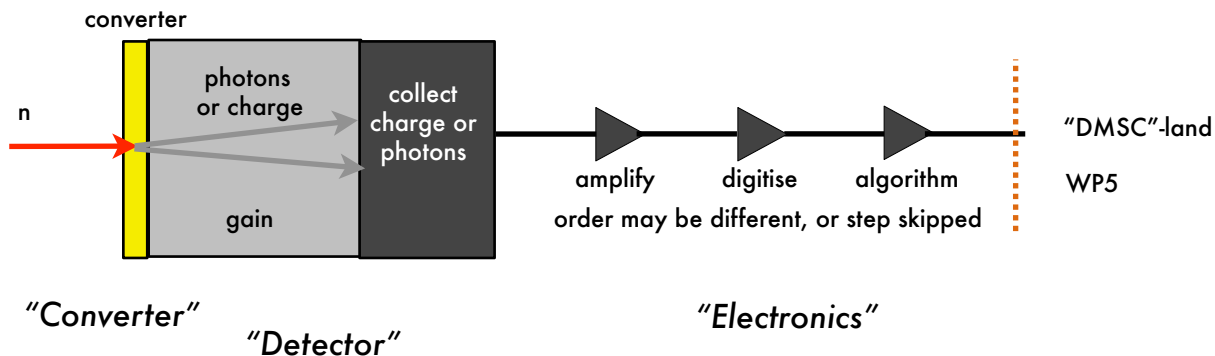
WP4





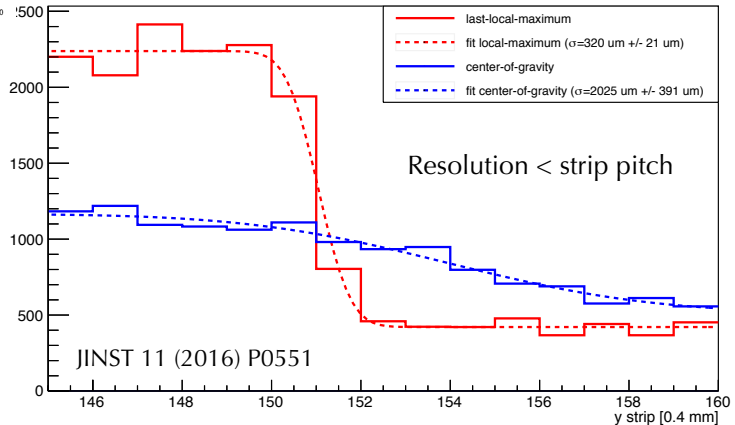
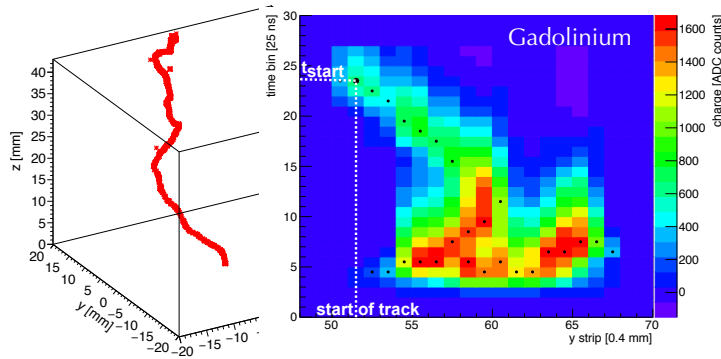
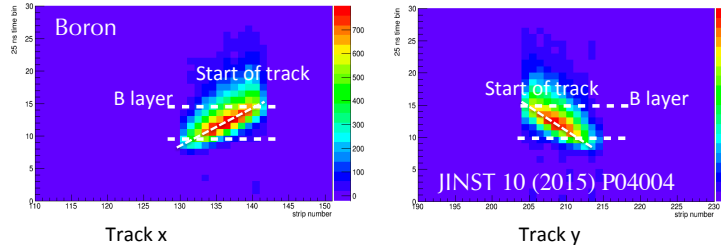
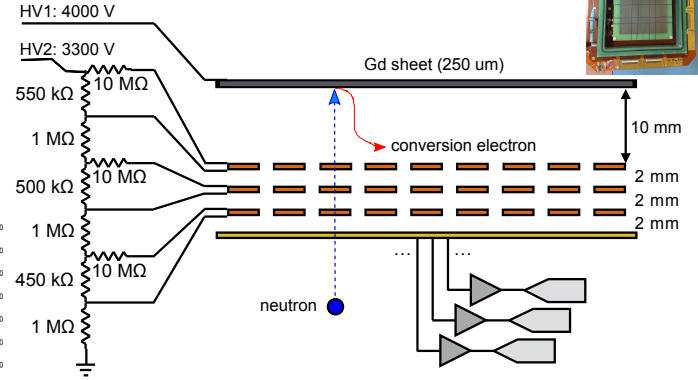
# Results

Efficient neutron converters a key component for neutron detectors



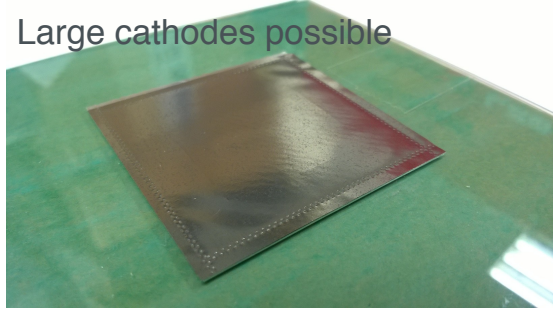
# Task4.1: The Resolution Challenge

- NMX:  $\ll 1$ mm position resolution requirement, Time Resolved, ca.  $1\text{ m}^2$  detector area
- Take Micro Time Projection Chamber concept from CERN ATLAS experiment upgrade
- Resolution: use single layer Gd, look for electrons

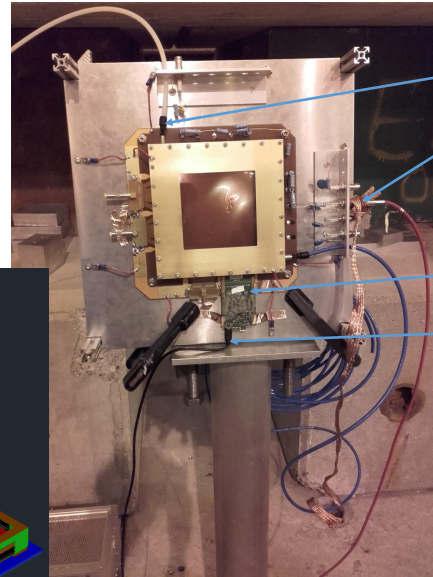


Ultrasonic Welding of Gadolinium

Large cathodes possible



VMM3 test beam



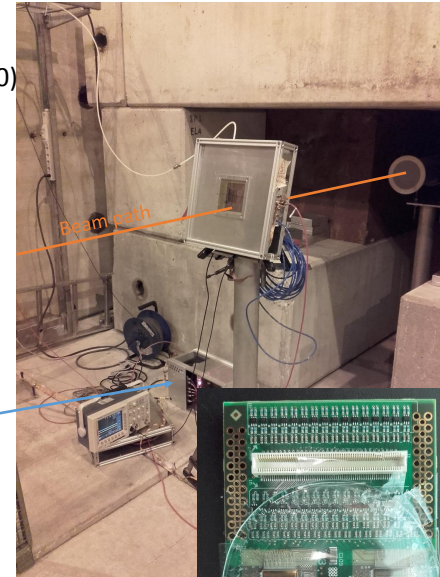
Gas (Ar/CO2 70/30)

High voltage

VMM3 hybrid

Data

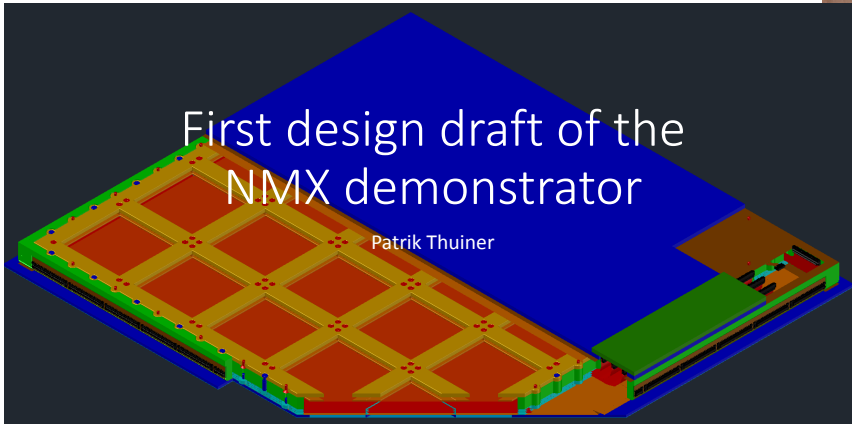
SRS Crate  
with FEC



Beam path

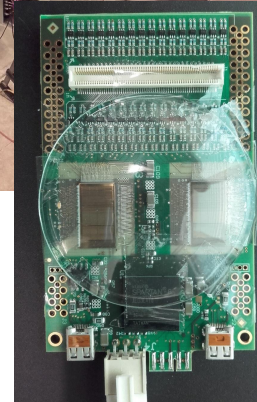
First design draft of the  
NMX demonstrator

Patrik Thuiner



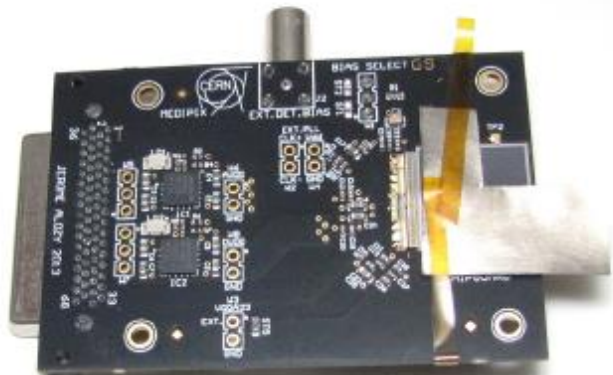
Electronics Test Beam this summer:  
Performance encouraging

50x50cm demonstrator under production now



VMM3 hybrid

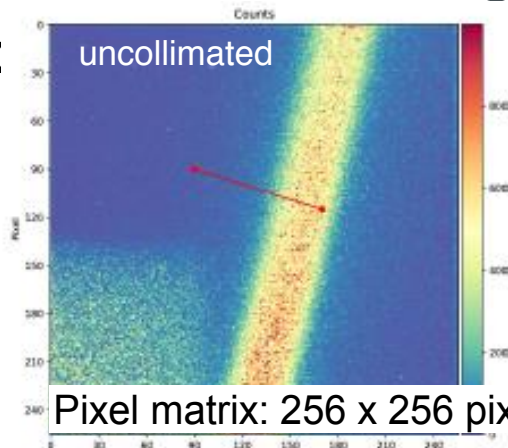
## Neutron Imaging with Timepix



Timepix3 detector with 25um gadolinium foil.

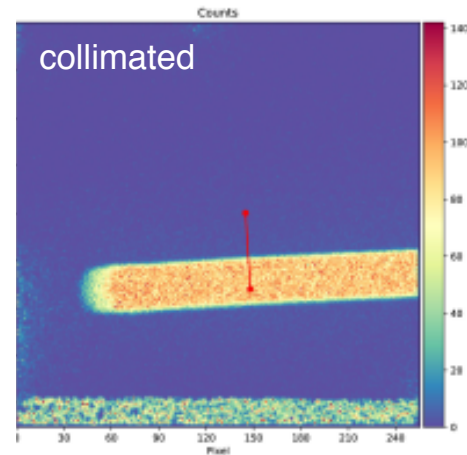
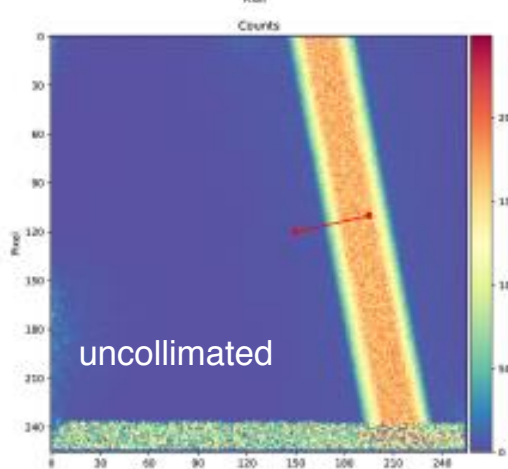


Fig 2: Timepix3 detector with 5um B<sup>4</sup>C coating with about 80% <sup>10</sup>B.



Pixel matrix: 256 x 256 pixels, Pixel pitch: 55 x 55  $\mu\text{m}^2$

Data taken at IFE, Norway

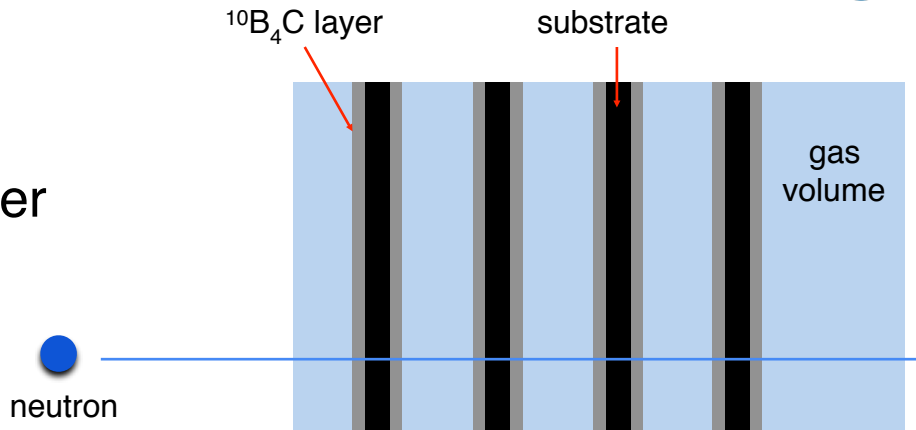


# Enhancing the efficiency of $^{10}\text{B}$ -based Neutron Detectors

Task 4.3

1

Multi layer

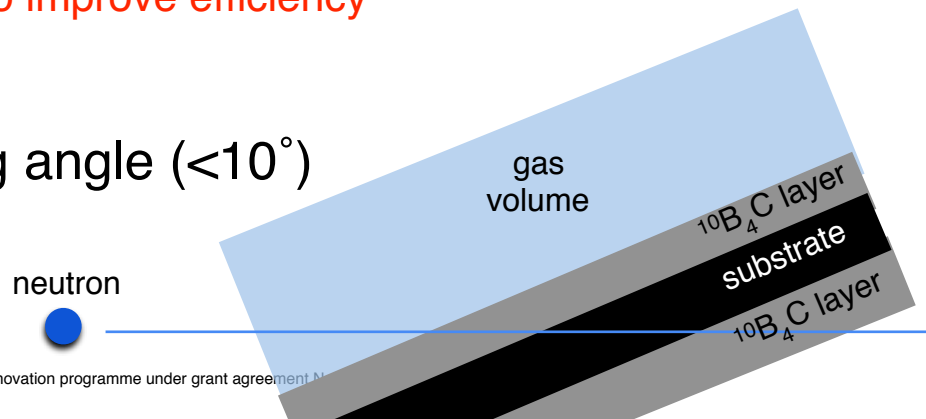


Generic approaches to improve efficiency

Task 4.2

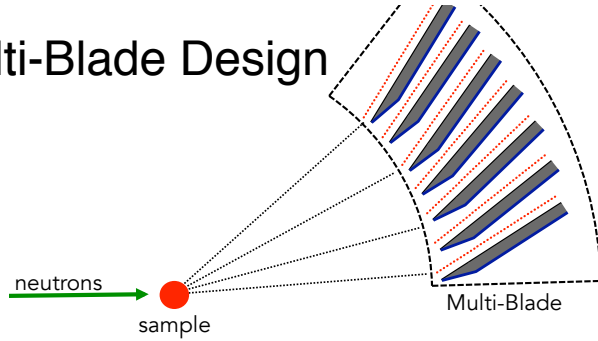
2

Grazing angle ( $<10^\circ$ )

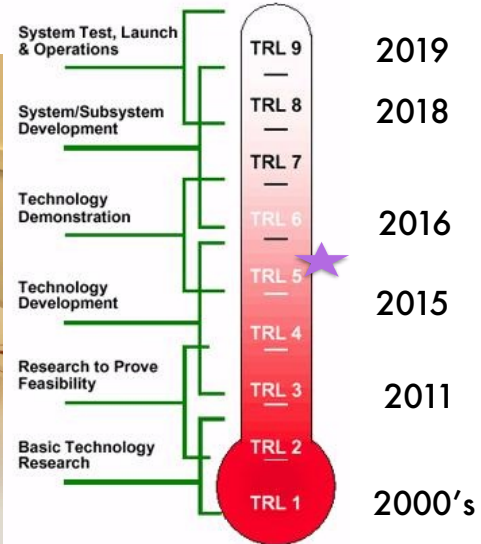
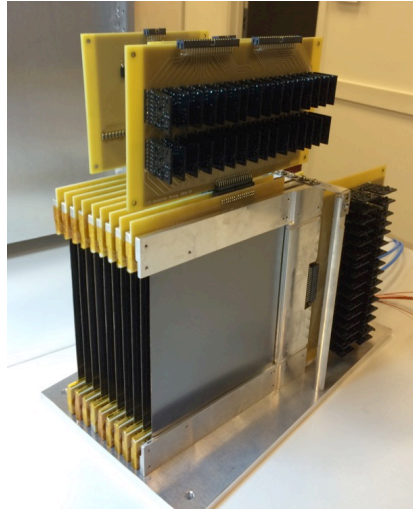
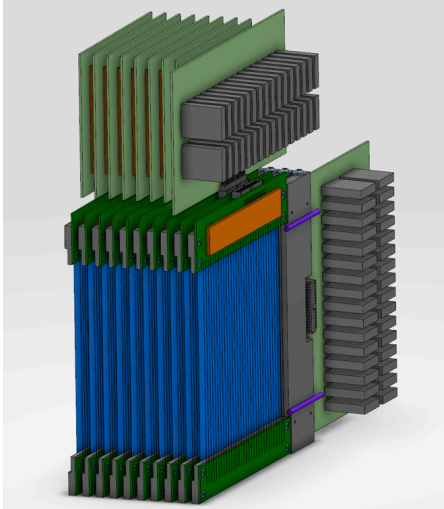


# Task4.2: The Intensity Frontier

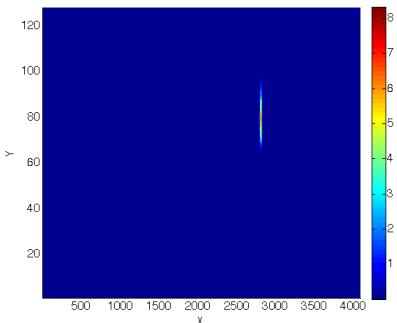
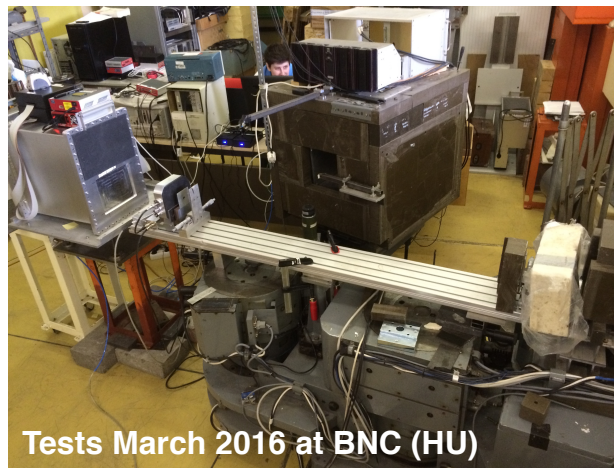
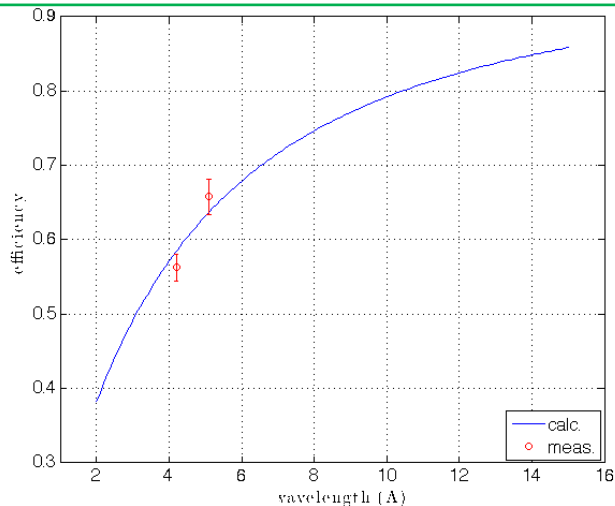
## Multi-Blade Design



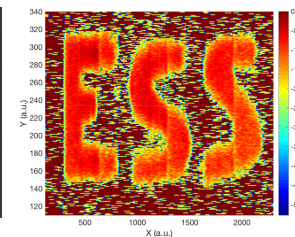
- Design simple: "KISS"
- Modular
- Cheap
- Make design available
- "Open Source Hardware"



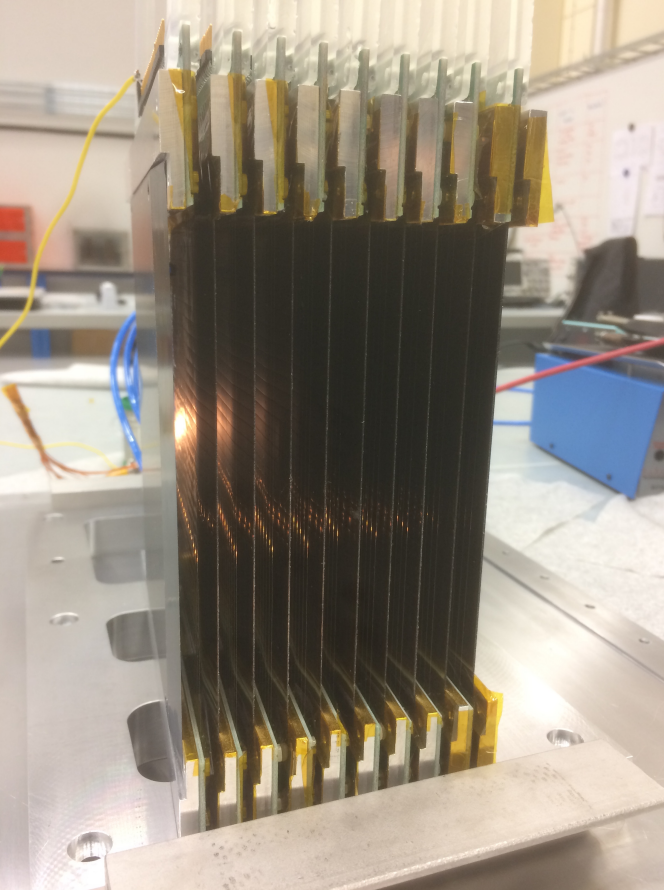
F. Piscitelli et al., The Multi-Blade Boron-10-based Neutron Detector for high intensity Neutron Reflectometry at ESS, JINST 12 (3) P03013 (2017).



- ➔ Counting rate capability: no saturation observed up to 22kHz/mm<sup>2</sup>
- ➔ ca. 0.4mm x resolution



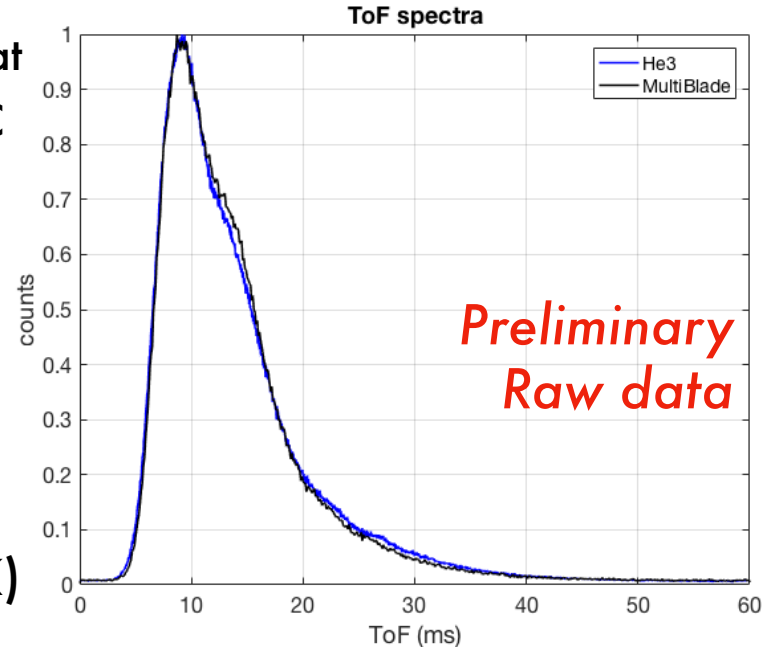


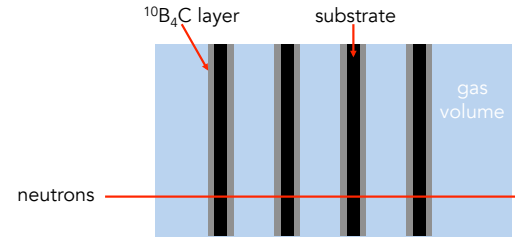
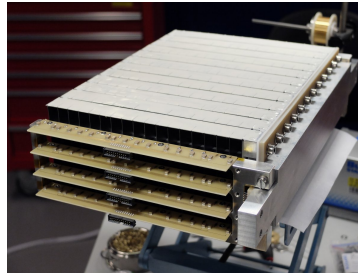
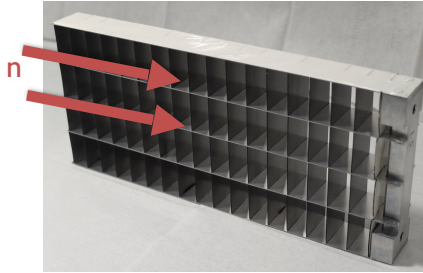


- Blade substrate changed from Al to Ti and SS
  - Absolute understanding of alignment
- Individual readout for every wire and strip

Data taken at  
Wigner-BNC  
recently

Next: scientific  
demonstration on  
reflectometry  
instrument(ISIS,UK)



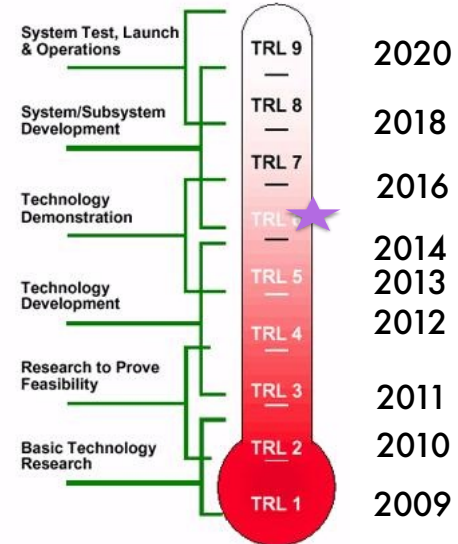


Technology Demonstrators of Scientific Performance planned for:  
CNCS@SNS and SEQUOIA@SNS

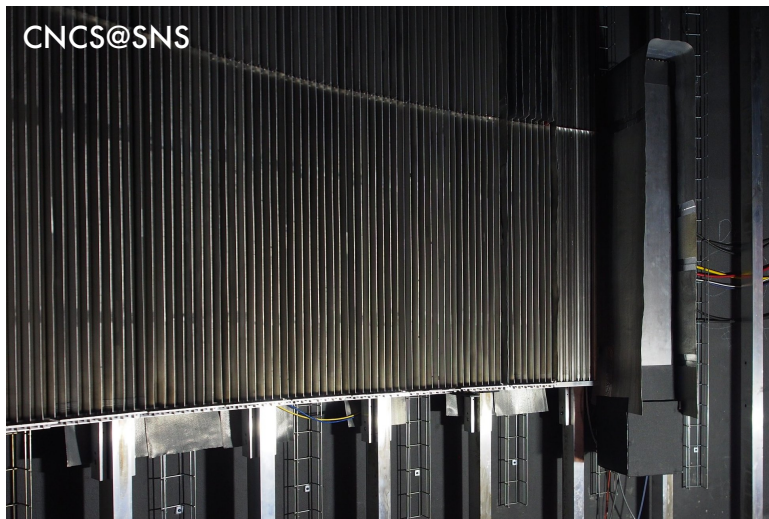
Multi-Grid Design  
Invented by  
ILL, co-  
developed ILL-  
ESS



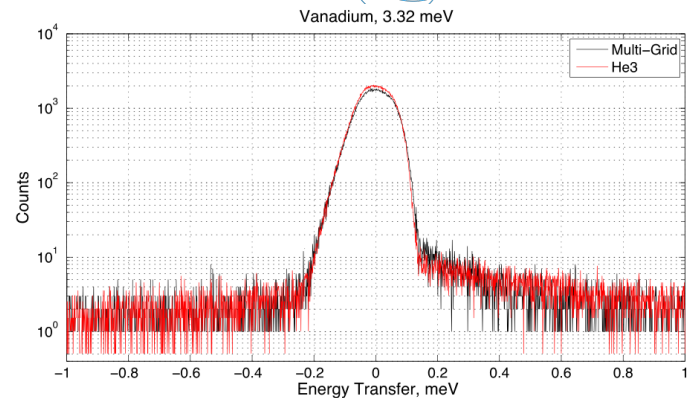
deliverable of  
CRISP project



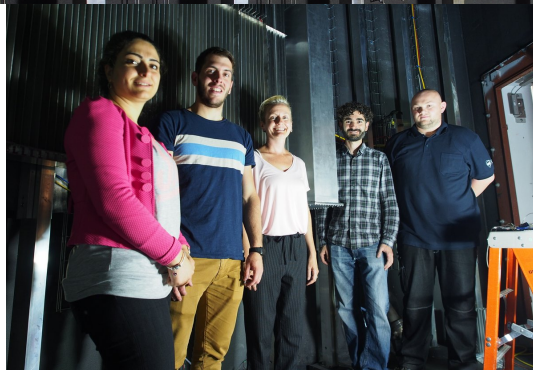
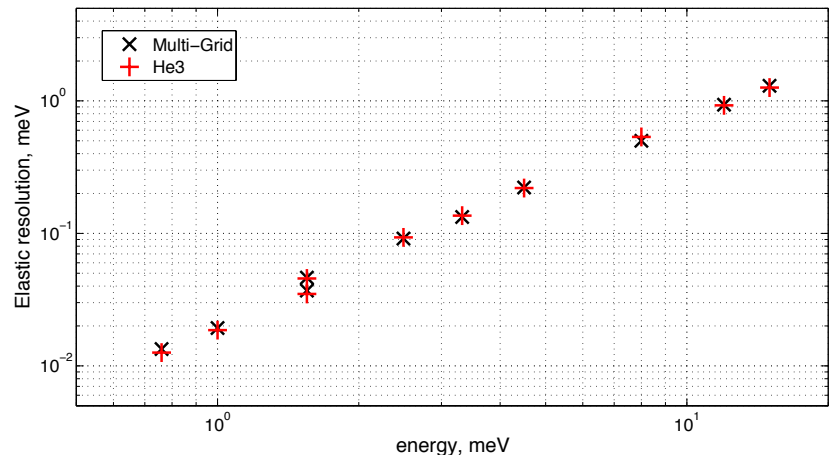
# brightness Task4.3: Realising Large Area Detectors



B10 Multi-Grid Detector  
Performance is  
equivalent to that of  
He-3 detectors



A.Khaplanov et al. "Multi-Grid Detector  
for Neutron Spectroscopy: Results  
Obtained on Time-of-Flight Spectrometer  
CNCS" <https://arxiv.org/abs/1703.03626>  
2017 JINST 12 P04030

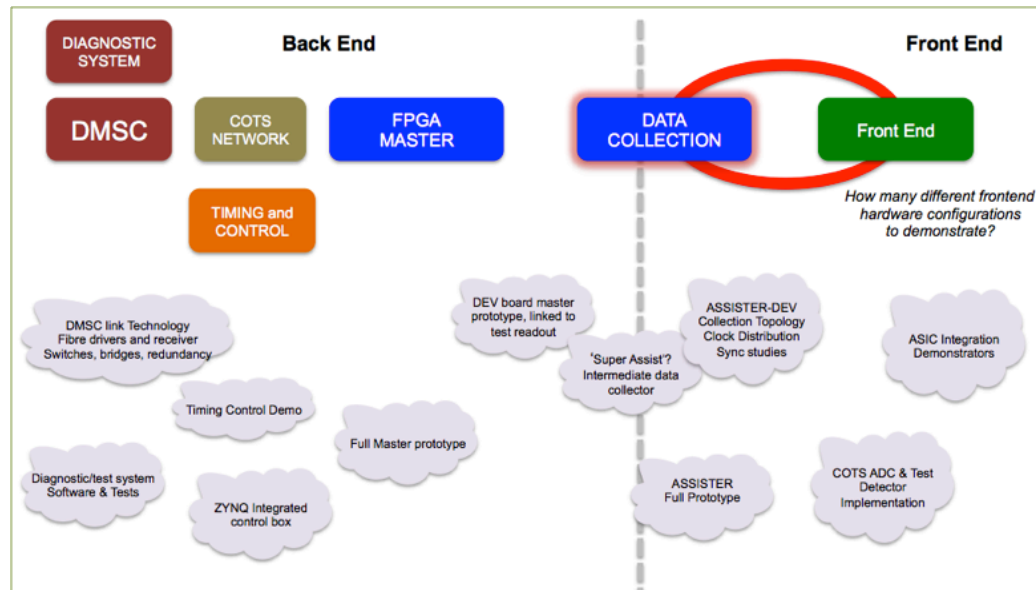
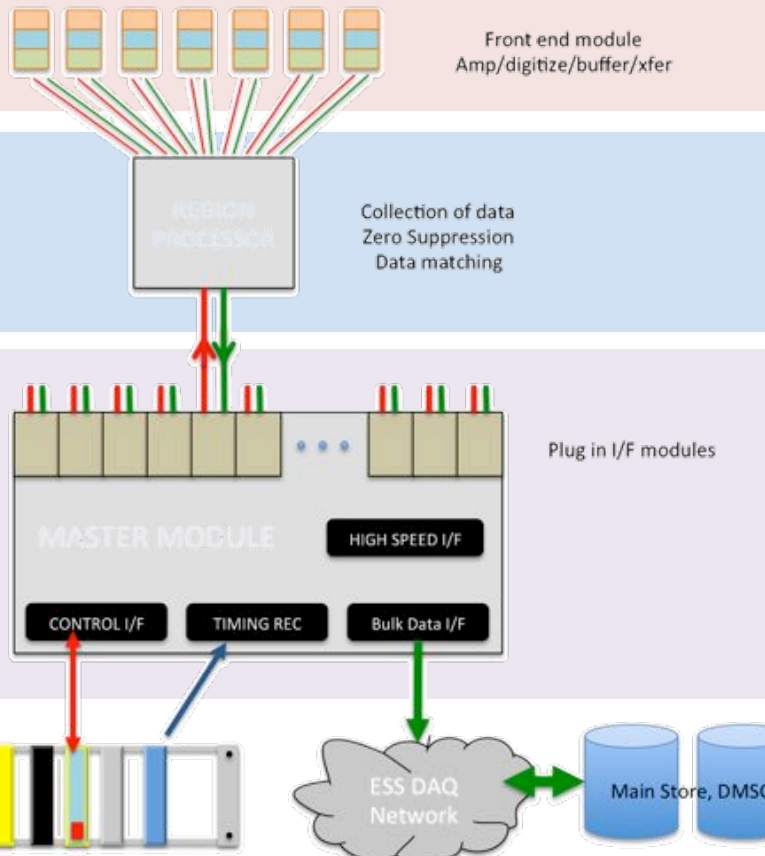




- Source Facility available at Lund University
- Detector testing possibility in Lund with (fast and thermal) neutrons, gamma
- Heavily used for all ESS detector activities

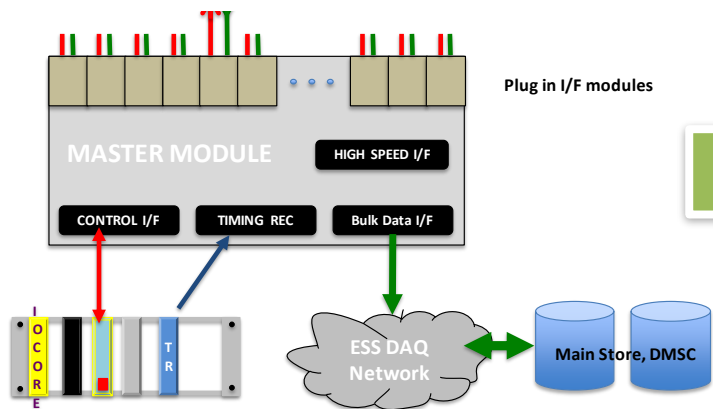


- Detailed plan for realising an integrated detector readout (D4.1)
- Cross-linked with Task 5.1



# brightness Work Package 4 and 5 Cross Links

- Interface between WP4 and WP5 a key interface for ESS instruments
- The sum of this interface defines the data acquisition path for neutron detector data at ESS
- Close and collaborative working relationship
  - Joint Kickoff meeting for task 5.1
  - WP4+5 Jamboree workshop 9-10 November 2016 in Copenhagen on event formation
  - WP4+5 Jamboree workshop 9 May 2017, Daresbury on data format & technical specification of data links
  - 2nd WP4+5 Jamboree workshop on event formation planned in a couple of weeks



# Next steps

- 6 WP4 deliverables remaining
- 7 WP4 milestones remaining
- Mainly technology demonstrators from BrightnESS
  
- Risks for the delivery of WP4: (mitigation)
- Relationship between partners: (open collaborative working between partners ; good project management)
- Interface with WP5 Data: (joint working meetings, shared responsibility for interface)
- Work permit for key person
- Technically, risks are under control
- Continuing impact of BrightnESS after end of project (open dissemination of results, seek opportunities for continuation of collaborations developed)





Richard Hall-Wilton  
Detector Group Leader  
European Spallation Source ERIC  
Mobile: +46 72 179 2089  
E-mail: [richard.hall-wilton@ess.se](mailto:richard.hall-wilton@ess.se)



In terms of ESS project risk, impact of BrightnESS is to move detectors and novel moderators from being high risk technical items into a normal level of risk

BrightnESS reduces the level of risk for the delivery of the ESS project

A big thank you to all our partners for a successful first half