

---

## Project CDR for the ESS Tuning Beam Dump Imaging System

### System Design Document

---

	Name	Role/Title
<b>Owner</b>	M. G. Ibison	Researcher, University of Liverpool
<b>Reviewer</b>	E. Adli C. Thomas	In-kind manager, University of Oslo Responsible person, ESS Imaging Systems

<b>TABLE OF CONTENTS</b>	<b>PAGE</b>
1. SCOPE.....	4
2. CONTRIBUTORS.....	4
3. ISSUING ORGANISATION.....	4
4. INTRODUCTION.....	5
4.1. Imaging Concept .....	5
5. CONTEXT (ASSUMPTIONS).....	6
5.1. Beam Parameters.....	6
5.2. Imaging Performance.....	6
5.3. Maintenance Lifetime.....	6
5.4. Principal Interfaces .....	7
6. SELECTION OF DESIGN OPTION .....	7
6.1. High-Level Design.....	7
6.1.1. Location in Dump Beam-line.....	8
6.1.2. Dump-Line Exit Window – Possible Option .....	8
6.2. Imaging System Components .....	8
6.2.1. Scintillation Screens.....	8
6.2.2. Screen Actuators.....	11
6.2.3. Viewports.....	11
6.2.4. First and Second Mirrors.....	12
6.2.5. Mirror Mounts .....	12
6.2.6. Imaging Lenses and Cameras.....	12
6.2.6.1. Camera Type .....	12
6.2.6.2. Remote Reset Functionality .....	13
6.2.6.3. Camera Housing .....	13
6.2.7. Illumination System .....	14
7. DESIGN OF THE FULL OPTICAL SYSTEM .....	14
7.1. Coated Window Viewing System .....	15
7.2. Screen Viewing System .....	15
7.3. System Optical Performance .....	15
7.4. Imaging outside the Visible Spectrum .....	16

8. MAINTENANCE CONSIDERATIONS.....17  
8.1. Cameras/Lenses.....17  
8.2. Screens.....17  
8.3. Actuators for Screens.....17  
8.4. Mirrors .....17  
9. SCHEDULE FOR IMPLEMENTATION.....17  
10. CONCLUSIONS AND RECOMMENDATIONS .....18  
11. GLOSSARY .....19  
12. REFERENCES.....19  
DOCUMENT REVISION HISTORY .....19

## 1. SCOPE

This document describes the detailed design of a system to image the proton beam transverse profile at the end of the ESS Tuning Dump Beam Line, immediately before the beam enters the front shield face wall of the dump itself.

It includes the design of the imaging system vacuum vessel which forms part of the beam line itself; the scintillation screens and their associated actuators, supports and control systems; optical transport elements including mirrors and lenses; and the specification for the image acquisition cameras with their supporting services such as cabling for power and data transfer.

## 2. CONTRIBUTORS

*M G Ibison      University of Liverpool*

*C Thomas      ESS Beam Instrumentation Group*

*T Grandsaert    ESS*

*E Adli            University of Oslo*

*P Aden            STFC Daresbury Laboratory*

*K Middleman    STFC Daresbury Laboratory*

## 3. ISSUING ORGANISATION

University of Oslo (in association with the University of Liverpool)

## 4. INTRODUCTION

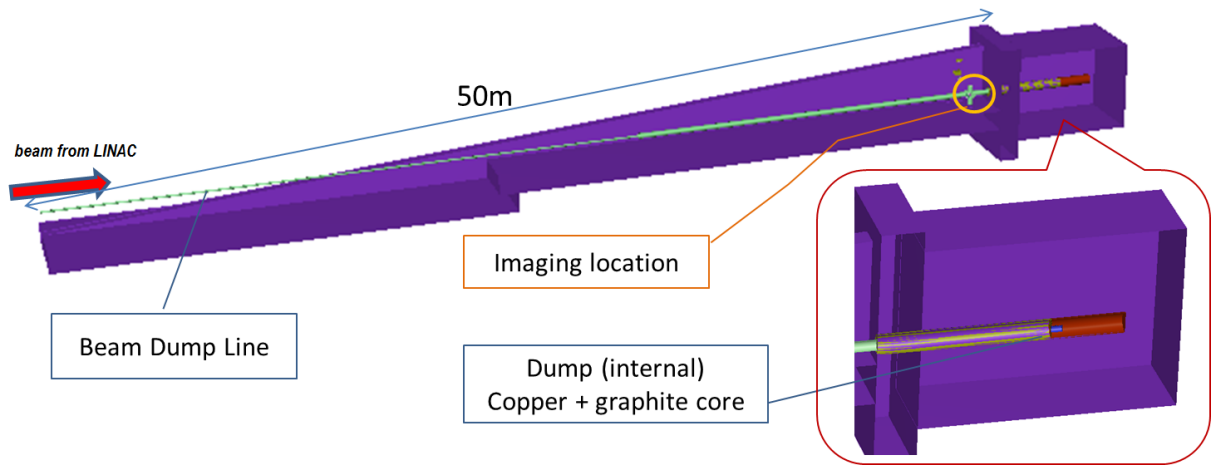

**Figure 1 Tuning Dump location and construction (RH shield wall omitted to shown beam-line)**

The ESS Tuning Dump is designed to stop proton beams having the full range of parameters which may be encountered during tuning activities of the linac, as detailed in [2]. The dump will be capable of handling an average beam power up to 12.5 kW with only passive cooling, and will accept full proton pulses but at a slower rate than with beam on target.

It is a heavily-shielded structure at the end of the dump beam-line [1], constructed of a massive copper cylinder with a graphite core as shown in Figure 1, surrounded by concrete except for the 500mm diameter entrance aperture.

The dump has a planned lifetime of at least 40 years without maintenance, and the goal for the life of the in-beam components of the tuning dump imaging system is also the lifetime of the facility, except for certain sensitive items detailed at 5.3 below.

### 4.1. Imaging Concept

An optical system is required to create a remote image of the transverse profile of the beam entering the dump, recorded at a point as near as possible to the end of the dump beam-line. For this, a single vacuum vessel will be used as in Figure 2, equipped to handle light from two sources:

- a) Dump Imaging: a coating applied to a window in front of the dump
- b) Beam Imaging: coated front surface of the imaging screen inside the vessel

To image the beam-on-dump, a clear view is of course necessary down the remainder of the beam-line, and it is assumed that there will be no intervening opaque obstructions. This view is provided at 90° by a mirror surface on the back of the screen; as the mirror is plane, it has no optical power and there is no effect on the available depth-of-field.

To image the beam on screen, a head-on viewing angle is preferred to avoid potential blurring due to any depth-of-field limitations in the optics, for such a relatively large

object. Processing of the final image in software can be applied to correct for the horizontal elongation of the beam profile arising from its 45° incidence onto the screen.

The capability of measuring beam profiles at two points provides redundancy and reliability. In addition, the few metres distance separating the two measurement points will enable the beam divergence to be measured.

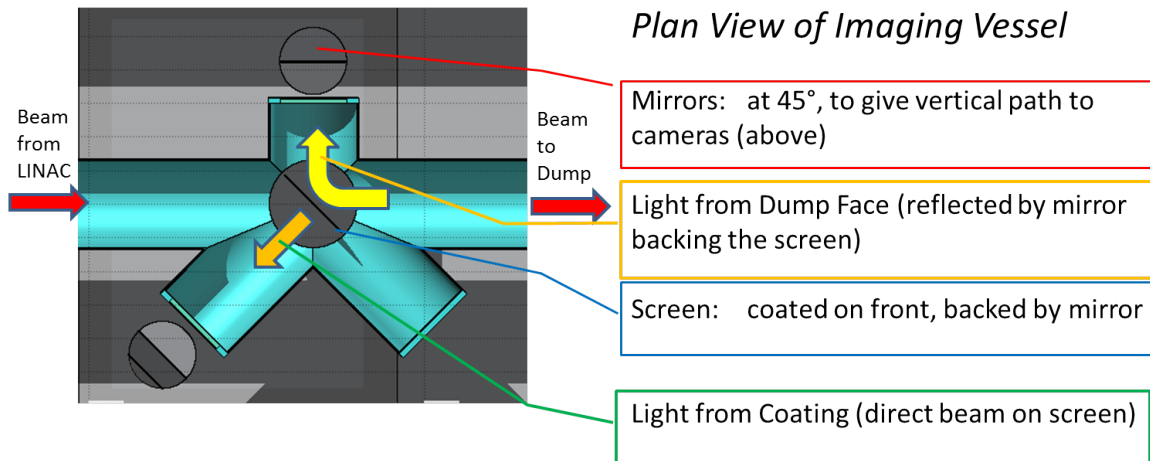

Figure 2 Imaging Concept, showing beam direction (red) and light paths (orange, yellow)

## 5. CONTEXT (ASSUMPTIONS)

### 5.1. Beam Parameters

At the Tuning Dump, a range of beam conditions will be experienced, depending on machine status and operating mode. As summarised in [2], for design purposes these have been interpreted as follows:

Maximum Beam Power	12.5 kW	Slow Tuning Beam (1 Hz)
Peak Average Current	6.3 $\mu$ A	
Study Time (beam available to Dump)	500 h	
Fraction of Study Time (beam on Dump)	0.5	

### 5.2. Imaging Performance

The system will be able to resolve details of 1mm in the beam image on screen or on the dump face. The field of view will encompass the full circular area of the screen, or the full area of the dump face exposed to the beam, within an overall diameter of 500mm.

### 5.3. Maintenance Lifetime

Components requiring routine replacement or maintenance will operate without attention until access is available during scheduled shutdowns. Pre-emptive action may

be taken to replace degraded items, if they are expected to become unserviceable before the next shutdown. This applies particularly to optical elements, primarily cameras and lenses. For this purpose, Minimum Lifetime has been taken as 1 year.

### 5.4. Principal Interfaces

External systems, and procedures which are the responsibility of other groups, but upon which this System Design depends, are detailed in a separate document [4].

## 6. SELECTION OF DESIGN OPTION

At the PDR for the Tuning Dump Imaging System [1], a baseline design was proposed, together with alternatives which had been explored in less detail. The baseline has now been developed more fully, and other options discarded. The concept relies on very simple optics, and minimises the number of elements and therefore the design complexity and alignment issues, while maximising the reliability and maintainability of the system.

### 6.1. High-Level Design

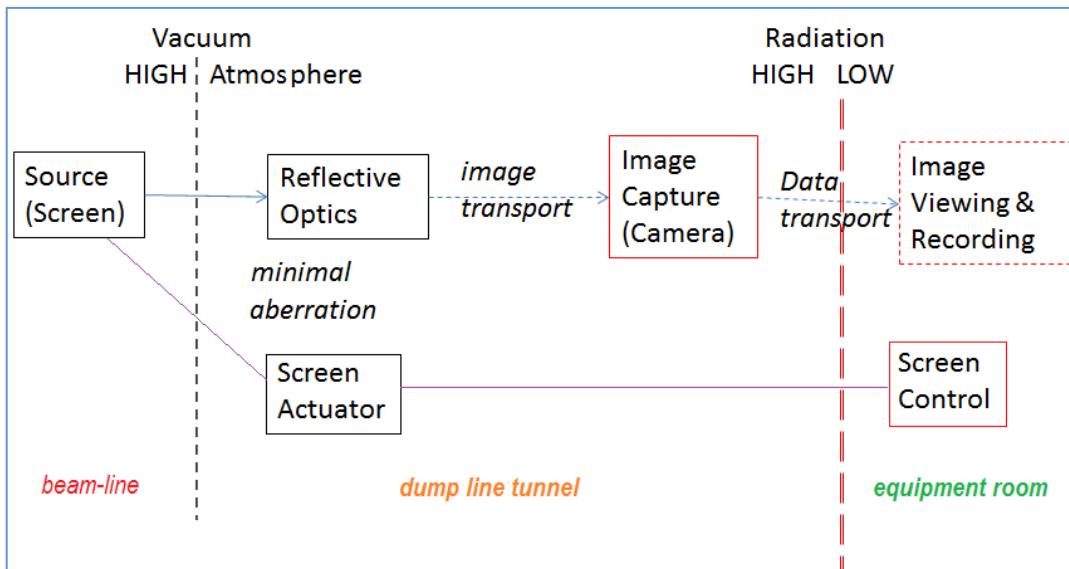

Figure 3 Imaging data flows and environments - block diagram (adapted from [1])

The design decision was taken to select Option (a) as considered for the PDR [1], that is, to locate the cameras within the tunnel close to the beam-line. Image transport is greatly simplified, with a maximum optical path length of less than 8m.; however, there are drawbacks, principally the limited useable lifetime for standard digital cameras in the high radiation environment of the dump tunnel, requiring maintenance access for regular camera changes.

### 6.1.1. Location in Dump Beam-line

The imaging system is the final diagnostic in the dump line, and its vacuum vessel will be one of the last elements before the dump entrance. This ensures that measurements with other instruments, such as the beam-position monitor (BPM), are not influenced by the protons scattered by the imaging screen.

Downstream of the vessel housing the screens assembly, there are two more elements: the window and the gamma blocker, as indicated in Figure 4. The exact arrangement is still under review.

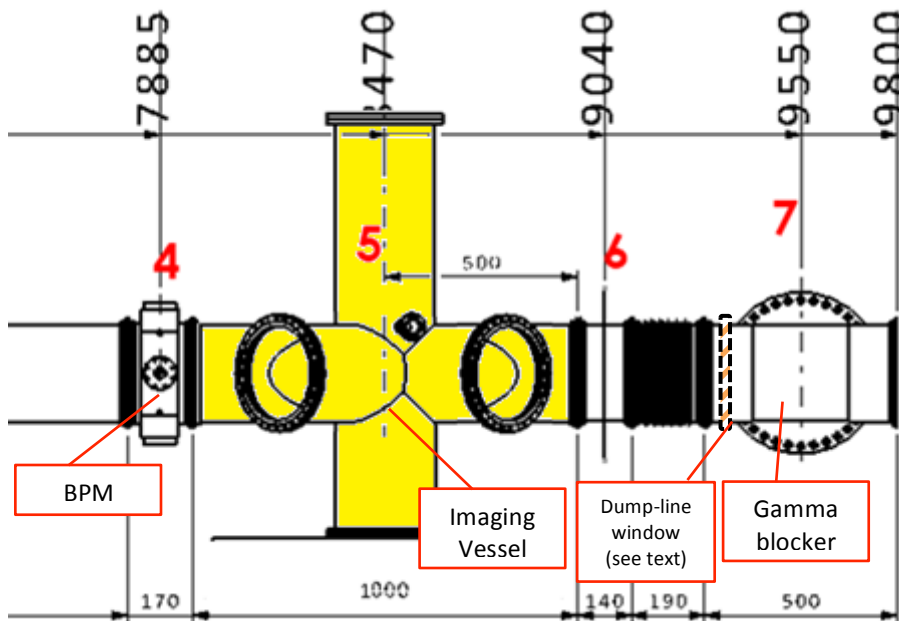

Figure 4 Mechanical Drawing of Dump Line final section (modified for updated Imaging Vessel design)

### 6.1.2. Dump-Line Exit Window – Possible Option

There is an ESS proposal to terminate the beam-line with a window, before the entrance to the dump itself, analogous to the proton beam window on the target line. The window would isolate the vacuum of the dump-line from entry of possible contaminants ablated from the dump by exposure to the energy of the beam. It would become a second source from which an image of the beam on the Dump could be taken. The gamma blocker has to be situated downstream of the window as seen in Figure 4, as it is there to enable maintenance in the area.

## 6.2. Imaging System Components

### 6.2.1. Scintillation Screens

The beam imaging screens will be subject to bombardment by protons at energies up to the full LINAC output of 2.0 GeV. Maximum average power levels, however, are expected to be no greater than 12.5 kW [2], of which the screens will dissipate only a small



fraction. Simulations have been carried out to predict the localised screen heating, in the worst case scenario [3].

Screens will have a minimum clear diameter of 200 mm, but with the option to increase this to 230 mm. They must satisfy a number of requirements:

- Resistance to radiation damage from 2 GeV protons
- Good mechanical strength for mounting and movement
- Vibration-damped against possible beam-pulse induced resonances
- Good thermal conductivity to avoid local overheating from small beam spots
- High melting point to resist beam burning and thermal-spray coating process
- Optical flatness across full aperture
- Available in thin sheets of thickness 0.5 – 1.0 mm
- Good adhesion for scintillating coating on front side
- Able to accept polishing, or to receive mirror coating on rear side

No single material is likely to possess all of these properties, and in simulation a composite structure has been investigated [3], combining the resistance and good mechanical properties of aluminium with the optical advantages of silicon, readily available in wafer form. This has an aluminium backing plate of 200  $\mu\text{m}$  thickness with a front beam-facing coating of 30  $\mu\text{m}$  thick chromium-alumina, thermally sprayed onto the backing. The aluminium is backed by a substrate of a 400  $\mu\text{m}$  thick optically-flat silicon wafer, and the final mirror coating on the rear is a layer of 20  $\mu\text{m}$  polished aluminium as in Figure 5.



**Figure 5 Details of layers for structure of simulated screen. Coating = GREEN, Backing = GREY, Substrate = PINK, Mirror = GREY. Total thickness = 650 $\mu\text{m}$**

Alternative screen materials are under consideration; these include polycrystalline diamond (pCVD), which has been tested for radiation hardness in proton beams.

Mounting frames will support the screens and also provide a linkage to the screen-changing actuator mechanism.

The screen changer facility will permit up to 3 alternative screens to be installed within the system at one time. This provides redundancy in case of screen failure, or unacceptable decline in light output which occurs with radiation dose. It also supports the

selection of different scintillators, which are currently under development at ESS and with many partners and collaborators across several institutes.

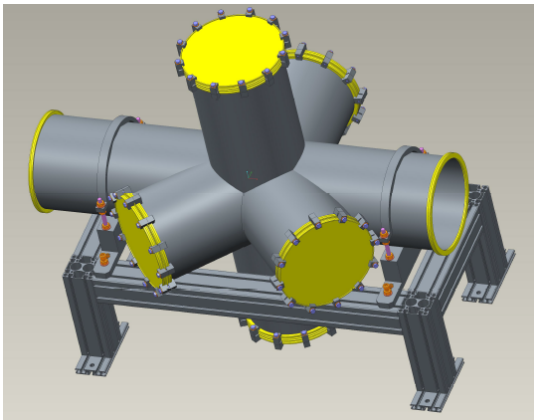

**Figure 6** Vacuum Vessel showing flanges (yellow) fitted with viewports, screen actuators, or blanking plates. *Note: Entry and exit beam-pipes are not shown here.*

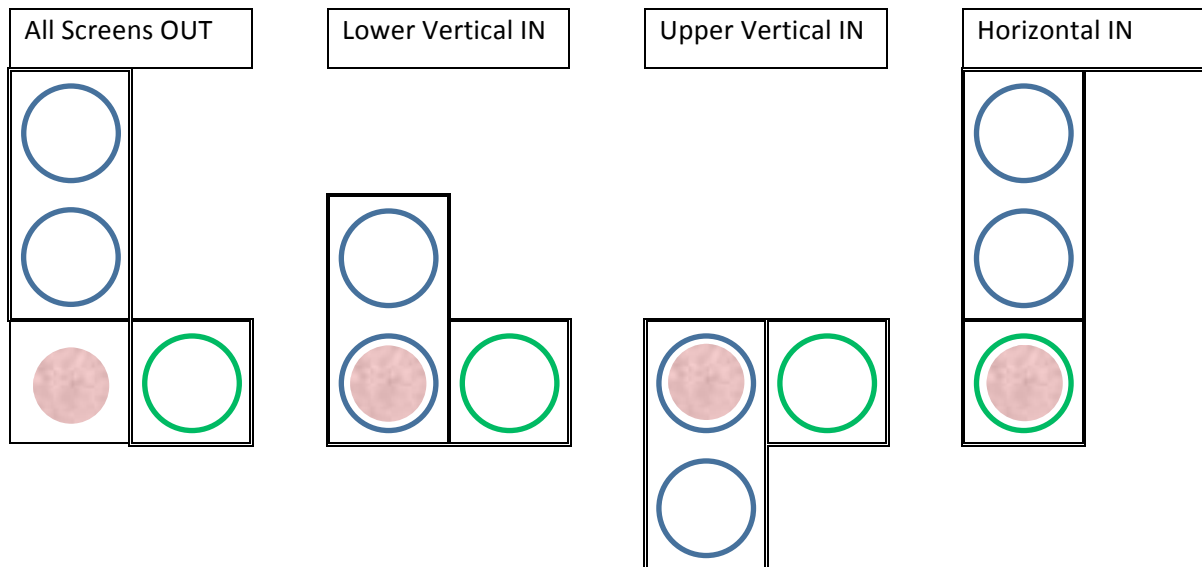

The vacuum vessel housing the screens is shown in Figure 6. It is sized so that 2 screens, on the same slider, can be accommodated in the upper vertical arm. Either of these ‘vertical’ screens can be lowered into place in the beam, and when the upper of the 2 screens is in use, there is also space for housing the unused lower screen in the bottom vertical arm under the vessel. The horizontal 45° cross, which appears to the right in Figure 6, houses a single screen, which can be slid into the beam only if neither of the ‘vertical’ screens is in place. Interlocks on the actuators will be necessary to prevent possible clashes: a horizontal movement will not be allowed until a vertical one (out of the beam) has been completed, and vice-versa. This type of scheme has been successfully implemented for screen changers at accelerator facilities elsewhere. All possible permutations are shown in Table 1.



**Table 1** Screen-in-beam selection permutations. Beam position is shown in pink.

### 6.2.2. Screen Actuators

The screens will be moved into and out of the beam by motorised linear actuators from the HLSML series by *UHV Design* [5], a series that has been proven in operation in existing accelerator facilities. Proposed types are summarised in Table 2 .

Orientation	Max Travel required	Type	Lifetime (cycles)
Vertical 	600 mm	Long Travel Linear Shift Mechanism	> 10,000†
Horizontal 	300 mm	Long Travel Linear Shift Mechanism	> 10,000†

**Table 2** Screen actuator types and properties (†Manufacturer estimate)

Limit switches are provided to control overshoot, and there will be interlocks to prevent screen insertion if beam-on-dump conditions could be a risk for screen damage.

The repeatability required for screen positioning between movement cycles will be  $\pm 1\text{mm}$  or better in both orientations. High precision is not essential, as size and intensity of the image is more important than absolute position.

### 6.2.3. Viewports

Viewports are fitted to two of the imaging vessel flanges as shown in Figure 6, to the 90° horizontal arm viewing the rear of the screen, and to the left-hand 45° arm viewing the front of the screen face-on. To suit the DN-250 beam pipe-work in the second section of the dump line where the vessel is located, viewports up to DN-200 are available, as shown in the example at Figure 7; in this diameter they will provide unimpeded sight of the full screen area. To avoid the darkening effect and consequent loss in transmission which typically occurs in standard glasses under irradiation, **fused silica** will be specified as the optical material for viewports [6].

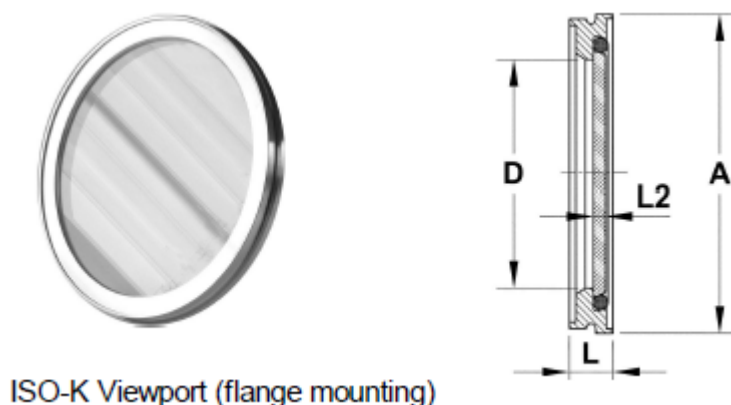

**Figure 7** Typical vacuum viewport, in fused silica. Clear diameter  $D = 200\text{mm}$ , Thickness  $L2 = 13\text{mm}$

#### 6.2.4. First and Second Mirrors

The mirrors allow the optical paths to be folded by 90° and the cameras to be located at a higher level, well above the beam axis. Both mirrors will be made of polished aluminium with a coating maximizing reflectance of the luminescence spectrum, and are expected to have a long life even in the harsh radiation environment. The options for eventual selection of suitable protective coatings are still being studied. Mirror planes will be at 45° to each viewport. Directly above each of the two First mirrors are the Second mirrors, set parallel to them and at 45° to fold the optical path to the horizontal.

Mirrors will be sized according to the required clear optical aperture; while for the first mirrors this implies a diameter of approximately 200 mm, second mirrors can be significantly smaller, corresponding to the additional path length between them.

#### 6.2.5. Mirror Mounts

For each optical system, frames having pairs of vertical posts are built on the tunnel floor and are braced at the top and at mid-height by brackets attached to the walls. Each frame has mountings for the First and Second mirror and these have adjustments for alignment purposes. Each mirror is supported in the first instance on an ESS-designed 'BendaMount' [7] shown in Figure 8, which provides stability as well as having 5 degrees of freedom; however, these are secured to horizontal platforms giving additional coarse vertical movement, which allows the First mirrors to be moved clear for access to the viewports.

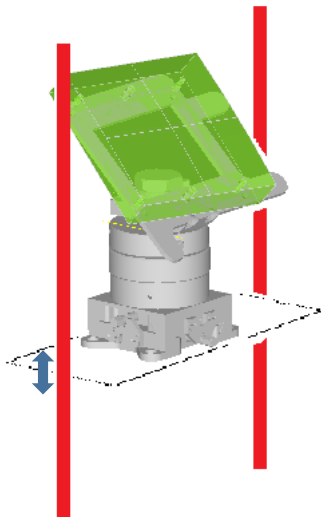

Figure 8 'BendaMount' versatile mirror mounting, showing mirror outlined in green and vertical supports in red.

A view of both sets of mirror supports in situ is seen in Figure 11.

#### 6.2.6. Imaging Lenses and Cameras

Standard camera lenses compatible with the selected camera body will be used to bring the image to focus on the camera sensor. Lenses will be subject to gradual 'browning' from radiation damage, but the rate of deterioration is not expected to require their changing any more frequently than the cameras themselves.

##### 6.2.6.1. Camera Type

The preferred option is to use standard machine-vision cameras based on a CMOS sensor, which will support the GiG-E data interface standard adopted elsewhere on the ESS project. This type has the advantage of ready availability, choice of vendor, readily-available support and relative cheapness, with good image quality and the option to fit off-the-shelf lenses.



A number of alternative radiation-hard camera solutions have however been considered, in case the preferred type proves unsuitable in service:

Figure 9 Typical CMOS camera [7]

- a) Specifically radiation-hard technologies, such as the older 'Vidicon' tube type still supplied by specialists (e.g. Mirion), or CID sensor types (e.g. Thermo Scientific)  
 Operational dose limits quoted are as follows:

<i><b>Make</b></i>	<i><b>Lifetime Dose</b></i>	<i><b>Imaging Dose-Rate</b></i>
Thermo Scientific	$3 \times 10^4$ Gy	$1 \times 10^3$ Gy/hr
Mirion	$2 \times 10^6$ Gy	$3 \times 10^4$ Gy/hr

- b) 'Off-camera' image acquisition types, which allow much of the processing to occur remote from the sensor, i.e. in a human accessible environment

### 6.2.6.2. Remote Reset Functionality

As single event upsets from radiation are to be expected, it is imperative that the camera power can be remotely operated via the control system, so that the cameras can be readily power-cycled after an upset.

### 6.2.6.3. Camera Housing

After considering a number of possible locations relative to the imaging screen, camera positions were selected to provide a good compromise between relatively low radiation dose during dump operation and ease of access for installation and maintenance.

Initial studies considered sub-floor housing below a shielding slab, with apertures and Second mirrors arranged to avoid direct radiation paths to the cameras. This was rejected because of difficulty in meeting dose-rate targets [3], while maintaining accessibility.

After assessing other options, including a downward-looking configuration which used only single mirrors, the final locations chosen were at high-level, 155 cm above the beam centre-line, within 'niches' cut deeply into the tunnel walls, shown in plan in Figure 10. Both cameras will be supported directly in the wall's concrete structure, but will be fitted onto platforms with levelling screws for vertical tilt alignment. Camera lenses will be kept well within the inside faces of the walls. Cut-outs will be positioned to avoid reinforcing bars within the concrete when core-

drilling, as far as possible.

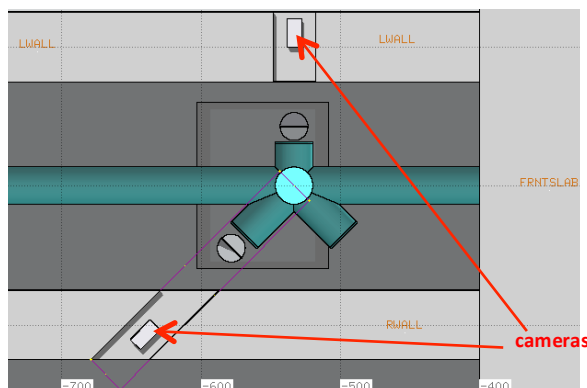
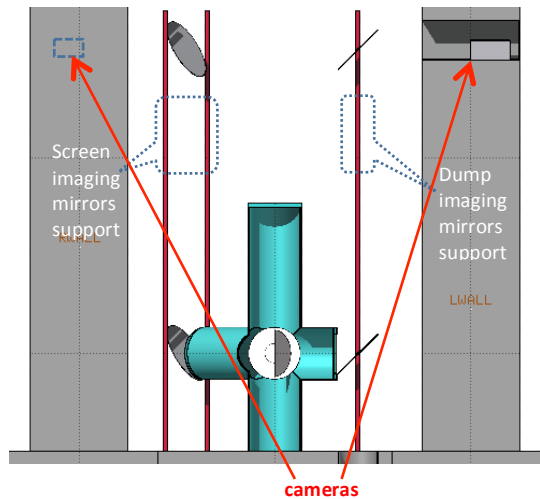

Figure 10 Camera Locations (plan view). Cameras are small grey rectangles denoted by the arrows.

The position of the dump imaging camera is shown in Figure 11, which also illustrates the two sets of vertical mirror supports, those for the dump imaging mirrors seen edge-on.



**Figure 11 Camera Locations (elevation, looking upstream from the dump entrance). In this view, the Screen Imaging camera (shown dotted) is hidden within the side wall.**

### 6.2.7. Illumination System

As a useful - but not essential – option, a built-in illumination system would provide lighting to make the screen visible on camera even when there was no proton beam. For example, this would allow any suspected screen damage to be examined. Such systems may be based on either

- an *array of LED lamps* inside the vessel in a ring formation, uniformly lighting the screen from points outside its circumference;
- or a *beam-splitter* using the light-path to the camera (in reverse) to direct light from a remote source onto the screen face.

Both arrangements have been used at other accelerator facilities. One consideration with the local LED system in particular is the possible effect of radiation scatter from the screen on the lifetime of the LED devices; this would require investigation.

## 7. DESIGN OF THE FULL OPTICAL SYSTEM

The complete optical design, including all of the imaging components in the light path as detailed in 6.2 above, has been entered into the ZEMAX Optical System Design Tool. This enables the optical performance to be evaluated for losses and aberrations affecting image quality. Except for the dual-function imaging screen/mirror, each system is optically independent, and therefore two separate models have been constructed, one for viewing the dump face (along the beam direction) and the other to view the screen (at 45° to the beam).

For each system, ZEMAX ray diagrams in Figure 12 and Figure 13 show the optical path, with colours denoting ray bundles emanating from selected field points at the periphery of the viewed object to the image on a camera sensor.

### 7.1. Coated Window Viewing System

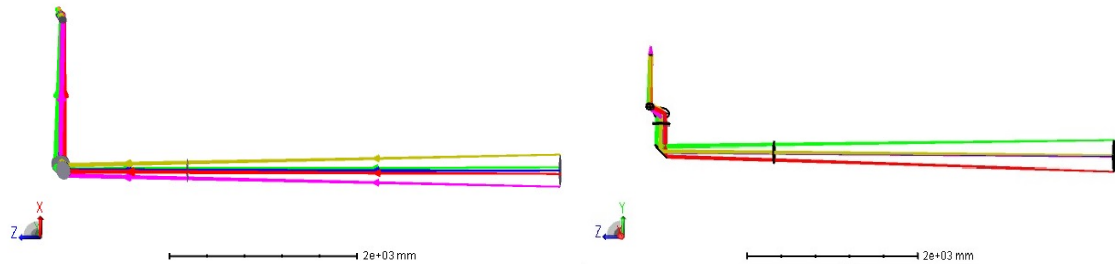

Figure 12 Ray diagrams of the Dump Viewing System: Elevation (L) and Plan (R)

The object is the face of the coated window, viewed down the entrance aperture. The optical path length is 7.88 m.

### 7.2. Screen Viewing System

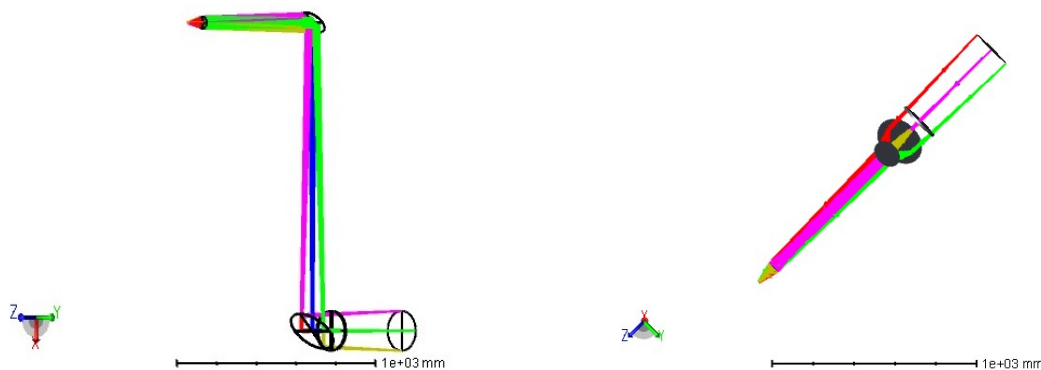

Figure 13 Ray Diagrams of the Screen Viewing System: Elevation (L) and Plan (R)

The object is the imaging screen, surface-coated with chromium-alumina. The optical path in this case is 2.96 m.

### 7.3. System Optical Performance

The only significant imperfection of the two optical systems is potential spherical aberration introduced by the camera lenses; this will be minimised by appropriate selection of the multi-element lens assembly.

Simulations of the images expected on the camera sensor for a test source object are illustrated in Figure 14. These are inverted by the mirrors, and while there is minimal distortion, they do show typical residual spherical aberration blurring. This can be overcome by the appropriate choice of lens assembly.

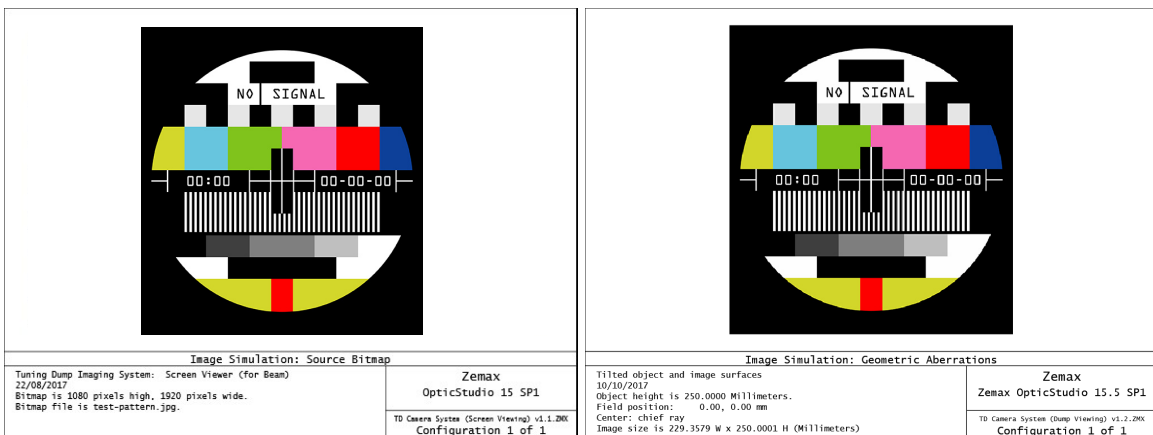
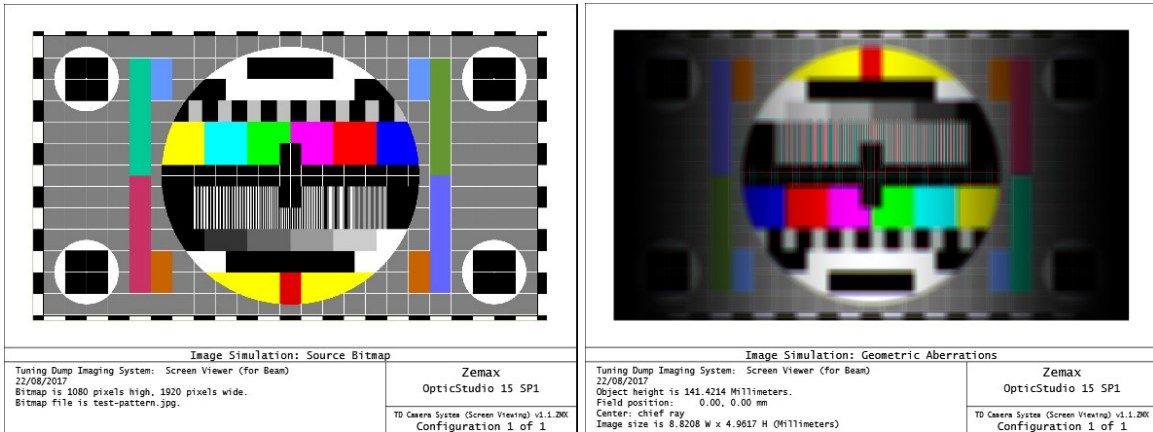

Figure 14 Simulated Images at the Camera: (TOP) Screen Viewing: Source object and Image, (BOTTOM) Window Viewing: Source object and Image

### 7.4. Imaging outside the Visible Spectrum

If infra-red imaging is required in the future, for example if required by testing of novel coatings in the dump line, alternative cameras will be necessary as standard CMOS sensors are not sufficiently sensitive at long wavelengths. A second camera may be mounted adjacent to the original one; if directly above, it can use the same transmission optics, a simple tilt of the Second mirror allowing radiation to be diverted into it.

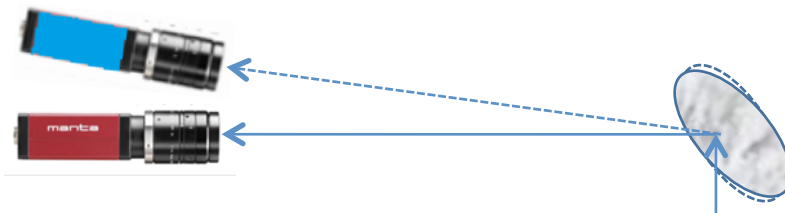

Figure 15 Alternative camera selected by simple tilting of the Second mirror about its horizontal axis



## 8. MAINTENANCE CONSIDERATIONS

As mentioned, several key components of the system are anticipated to have limited lifetimes, i.e. short compared to the 40+ years of the ESS facility itself. Procedures for changing these items safely and efficiently, and restoring the systems to their original performance, are under development.

### 8.1. Cameras/Lenses

The cameras are relatively accessible, being a little over head-height above the tunnel floor (about 2m). Removal involves disconnection of power/signal cables and loosening them from their mounting plates. Replacement with exact replicas will be just the reverse; but for a different model, some realignment and refocussing may be necessary. The tilt of the Second mirror may also be involved to maintain the correct field of view.

### 8.2. Screens

The need for screen replacement will be indicated by a significant fall-off in beam image intensity. Except in emergency, it will generally be more efficient to replace all 3 screens at the same time, when each has been in the beam and come to the end of its useful life. The procedure is defined by the vacuum handbook [9]. Some additional procedures should be defined, however, as the environment will have limited access time due to the radiation level [3].

### 8.3. Actuators for Screens

The motors and control electronics, with their position encoders, are outside the vessel and may be replaced fairly readily should they become faulty. Certain radiosensitive parts may benefit from shielding – although it will be difficult to position enough thickness to be effective – or remote placement, if possible without exceeding recommended cable lengths.

### 8.4. Mirrors

The mirrors are subject to radiation exposure, especially the First, but significant damage is unlikely. Severity of effects on mirrors in the much more exposed Target area are under investigation, and any measures considered necessary for those mirrors, such as anti-corrosion coatings, may be applied to the Dump mirrors unless the cost penalty is major. As long as there is no detectable radioactivity, after the statutory cooling delay, mirror replacement will be straightforward, realignment being aided by use of the cameras.

## 9. SCHEDULE FOR IMPLEMENTATION

The scheduling of the Imaging System implementation will be heavily dependent upon the plans for installation of the Tuning Dump beam-line vacuum vessels, managed by STFC (Daresbury, UK). After delivery of the imaging vessel and its connection to the beam-line, the integration of the screen assemblies and their actuators will take place. Preparation of the two camera mountings in the tunnel walls should be completed in

advance of the introduction of the vessel, for ease of access. Following the commissioning of the screen actuators, the mirror supports can be installed in the tunnel, before the mirror-pairs themselves are mounted and aligned using the cameras.

Milestone	Date	Notes
CDR Approved	Oct 2017	
Vessel Specification issued to manufacturer	Jan 2018	
Vessel Delivered	March 2019	
Beam-line completed (upstream of Vessel)	April 2019	
Vessel Integrated to Beam-Line	May 2019	
Actuators Delivered	April 2019	
Actuators integrated and Tested in situ, with screens	May 2019	
Cameras installed and cabled	June 2019	
System aligned and tested	July 2019	
First Beam-on-Dump	Oct 2020	(Date revised Oct-17)

**Table 3 A listing of principal milestones for the Tuning Dump Imaging System**

A detailed Implementation Plan will be published separately.

## 10.CONCLUSIONS AND RECOMMENDATIONS

The proposed design for the Tuning Dump Imaging System is based on an analysis of the beam parameters and the planned ESS operating schedule, experience with similar systems designed for other large accelerator facilities, the simulation of the optics and the consideration of the system’s operating environment. Simplicity has been a key factor in minimising risk and in helping to assure longevity and maintainability when failures do occur during operation.

Standard commercially-available components are specified, with the exception of the special screens; however, provision is made for the rapid switching of these without interrupting operations, short of a catastrophic screen breakage under irradiation, which

is considered only a remote possibility. Screen lifetime is however the most serious risk factor remaining in the design.

## 11.GLOSSARY

Term	Definition
CMOS	Complementary Metal Oxide Semiconductor, an active pixel technology
<i>GiG-E</i>	Interface standard for high-performance industrial cameras using Gigabit Ethernet communication protocol
PDR	Preliminary Design Review
DN-xxx	<a href="#">‘Diametre Nominal’</a> , a metric standard for pipe size, of nominal diameter xxx mm
LINAC	LINear Accelerator

## 12.REFERENCES

- [1] ‘Dump optical system preliminary design’ (ESS Document ESS-0066915)
- [2] ‘Tuning Dump Utilization (draft)’ (Tom Shea, Jan 10, 2014)
- [3] ‘Radiation Dose Estimates CDR Document’ (ESS Document ESS-0150754)
- [4] ‘Interface Definition CDR Document’ (ESS Document ESS-0150758)
- [5] Technical Datasheet: Long Travel Linear Shift Mechanism  
<https://d2129m0g0hc1fl.cloudfront.net/uhvdesign/media/literature-downloads/hlsm1-02-2015.pdf>
- [6] Vacuum Optics – Standard Viewports (VACOM)  
<https://www.vacom.de/en/downloads/vacom-product-catalog?download=2449:vacuum-optics>
- [7] CDR Bendamount document (ESS Document ESS-xxxxxx)
- [8] GigE VISION CAMERAS: Manta Technical Manual (Allied Vision)
- [9] ‘ESS Vacuum Handbook’, May 2014 (ESS Document ESS-XXXX)

## DOCUMENT REVISION HISTORY

Revision	Reason for and description of change	Author	Date
1	First issue	M Ibison	<<YYYY-MM-DD>>