

Electrical Engineering

In ESS Instrument Projects

Thomas Gahl

IKON14
14th February 2018

Distributed Control System

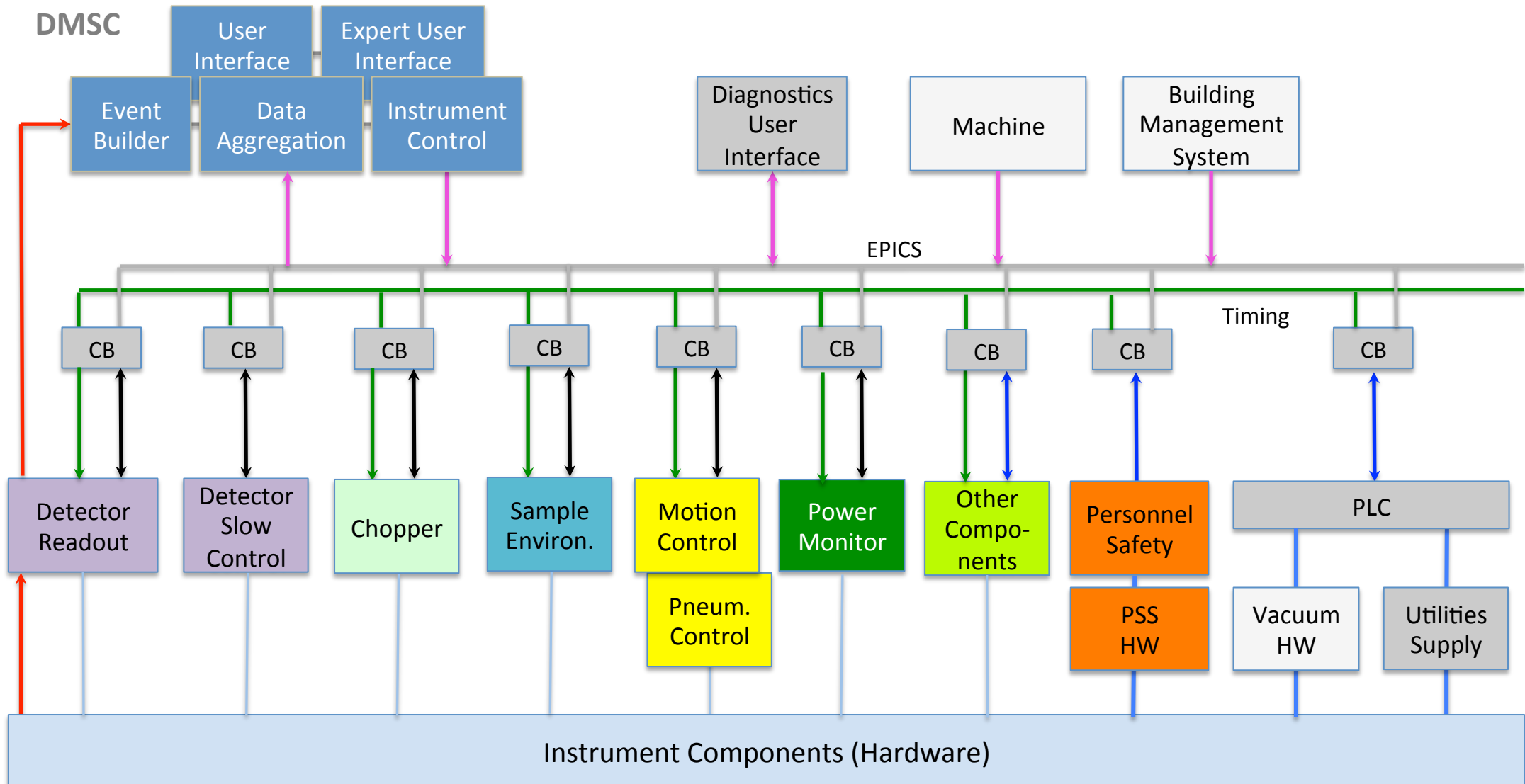

Electrical Engineering – A Coordination Role

1. Electrical Power Distribution
2. Electrical Drawings (ePLAN package)
3. Integrated planing for cables and cable tray installations
4. Integrated planing for cabinets and racks

1. Electrical Power Distribution

Substation
(Transformer)

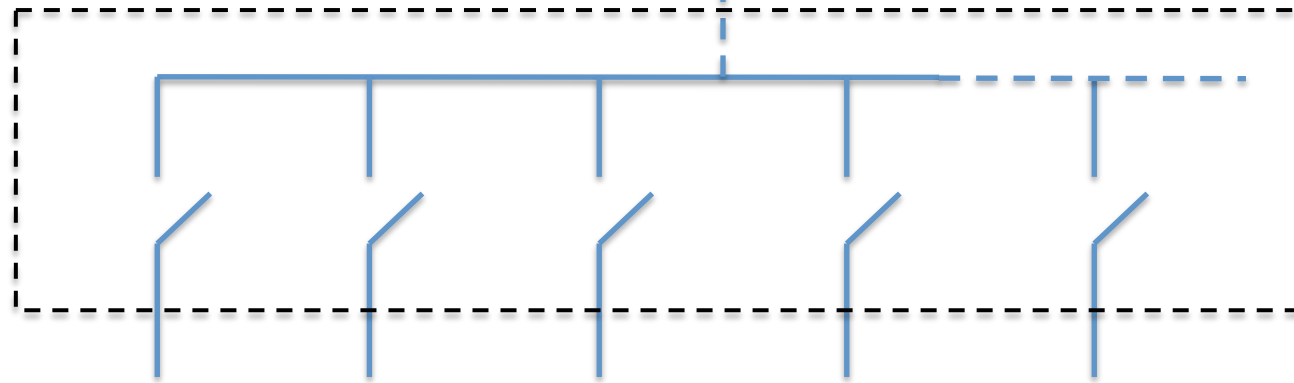
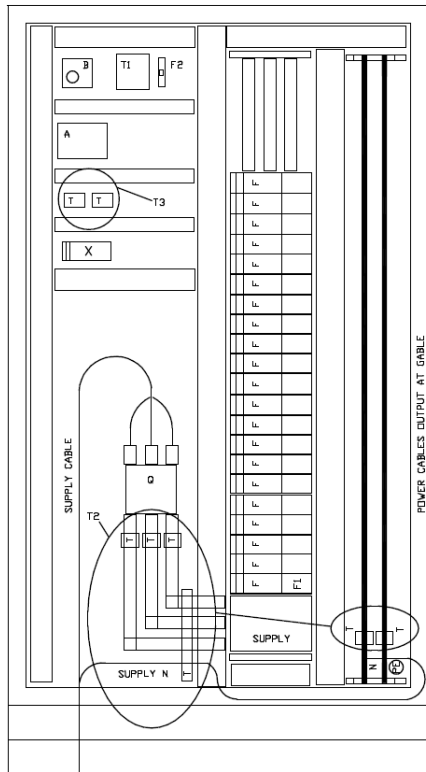
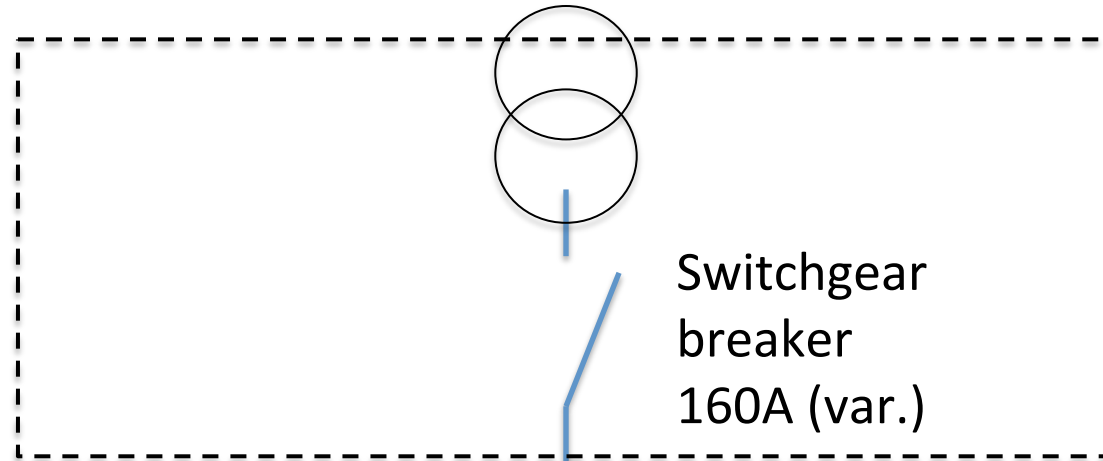

Instrument
Distribution
Panel

# 1	# 2	# 3	# 4	# n
Motion	Chopper	Detector	SE	Light, Hutch

- ESS will deliver the electrical power distribution panels for Instruments, but we need input from the Instruments teams:
 - List of consumers, i.e. output circuits of the distribution board
 - Characterisation of consumers
 - Calculated power consumption and peak values according IEC 60204
 - Power cables definition according IEC 60204/60364
 - Characterisation of short circuit capacity range of the instrument
 - Do you foresee your own sub-distribution panels e.g. in the sample prep area or in the controls hutch?
- To minimise EMI caused by distribution over the power network we need information from the teams about electrical components:
 - List / inventory of EMC relevant components (frequency converter, switching power supplies, digital electronics etc.)

2. Electrical drawings (ePLAN package)

- ePLAN is the tool for design and documentation of electrical circuits on ESS instruments
- For in-kind partners access via remote-desktop to ESS server possible
- Currently available licenses:
 - Version: ePLAN P8 Ver. 2.5
 - Add-on: Pro-Panel (3D)
- General guidelines:
 - Use of a common library (data base) for ESS standard components
 - Use of ESS naming convention for components, cables etc.
 - More info in document ESS-0028698 v2!
- Templates for ESS instruments projects will be developed in an in-kind project with FZ Jülich (available 2018)



General guidelines for use in ESS projects

- More details in the document
ESS-0028698 *E-Plan at ESS* v2
 1. Abbreviations
 2. Introduction
 3. Information structure for ePLAN
 4. Using parts and parts database in e-PLAN
 5. Working with projects in E-Plan
 6. User rights in E-Plan
 7. General Principles
 8. Naming of files and documents
 9. Support
 10. References

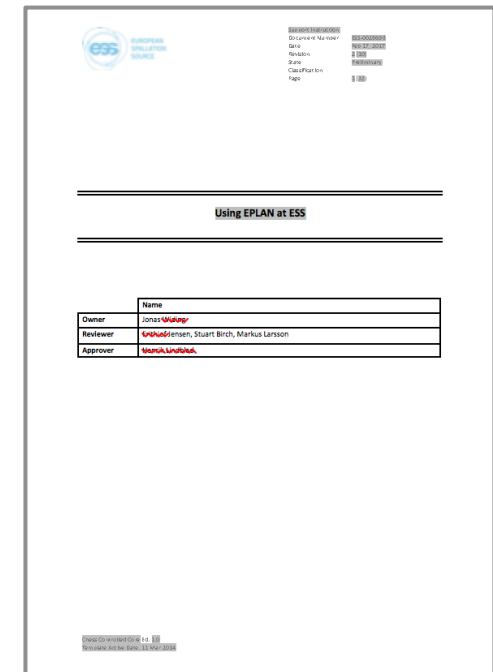

Instruments template

- The ePLAN set of drawings shall represent all electrical installations on an ESS instrument.
- Interfaces to ESS infrastructure are the power + grounding cables and the optical fibers for detector data, ICS/DMSC and PSS.
- The structure of the ePLAN project shall be uniform for all ESS instruments.
- The ePLAN project shall consist of a framework of overview pages, several modules according to the different technologies and a consolidated cables and components list.
- Naming of cables and components shall be consistent throughout the whole ePLAN instruments project.
- Some modules may be included in ePLAN as “black boxes” with well defined interfaces.
- The documentation of these boxes may be done outside ePLAN (other E-CAD systems, pdfs etc.).

Instruments template – Tentative structure

- Proposal for a structure of an ePLAN project for ESS instruments:
 - Overview: Block scheme, int. connections, ext. interfaces (Instruments team)
 - Power distribution I: Switchboard, mains analysis (NSS-ESS)
 - Power distribution II: Light, sockets, HVAC? in SE + control hutch (NSS-ESS or Instr. team)
 - ELV: Fire alarm, intercom, access control etc. ???
 - Grounding (NSS-ESS)
 - PLC System: Vacuum, Cooling (ICS-ESS)
 - Motion control (Instrument team)
 - Sample environment (SE) (Instrument team)
 - Chopper (Instrument team)
 - Detector (Instrument team)
 - Instrument protection system (local MPS) (MPS-ESS?)
 - Personal Safety System (PSS) (PSS-ESS)
 - IT instruments infrastructure (ICS-ESS)
 - Cables list, material list, connection list etc. (Instruments team)

- The instruments team needs to nominate the main responsible for ePLAN and coordinate the consolidation of the drawings for the different modules in one ePLAN project (drawing package).

3. Integrated planing for cables installations

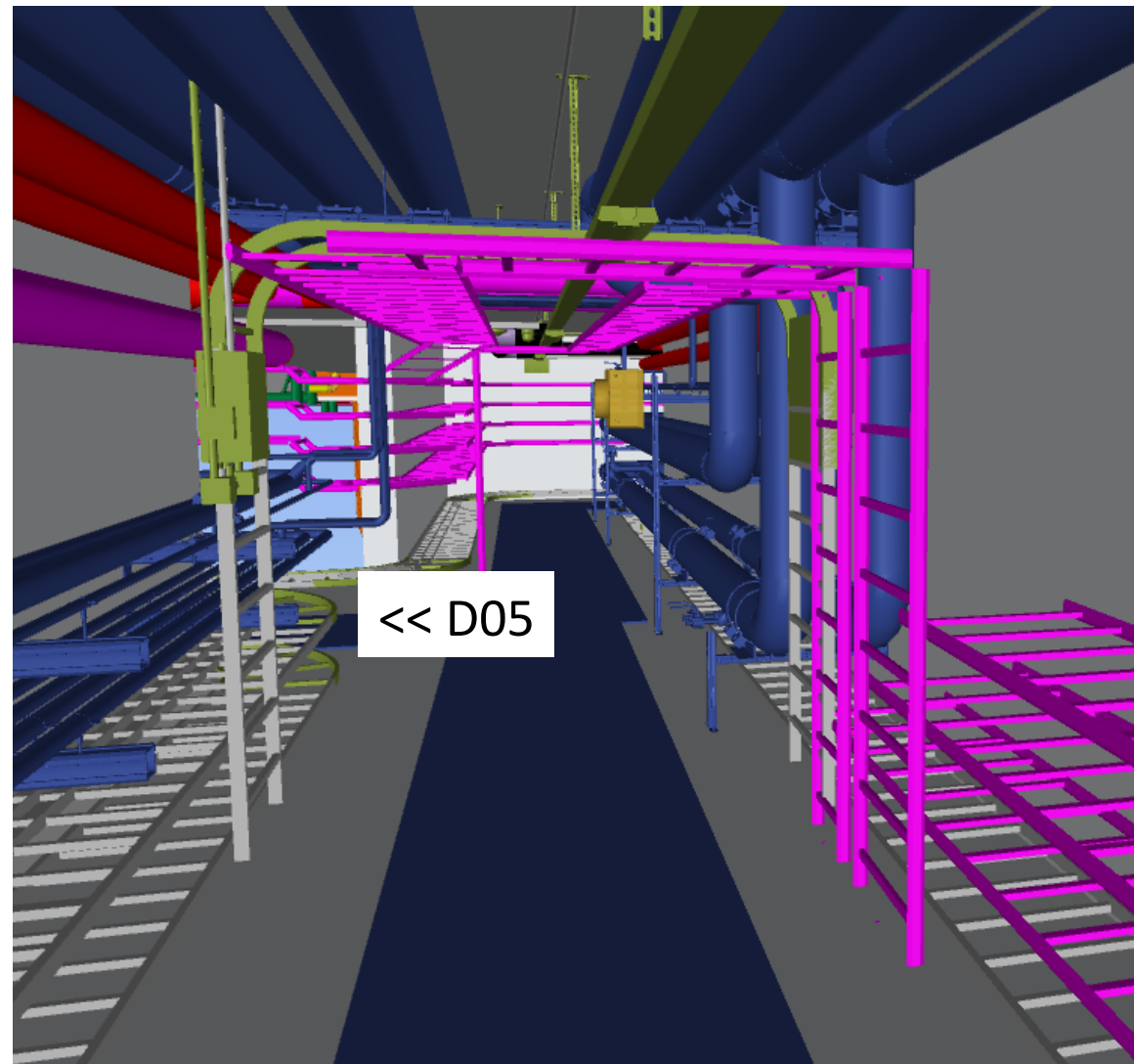
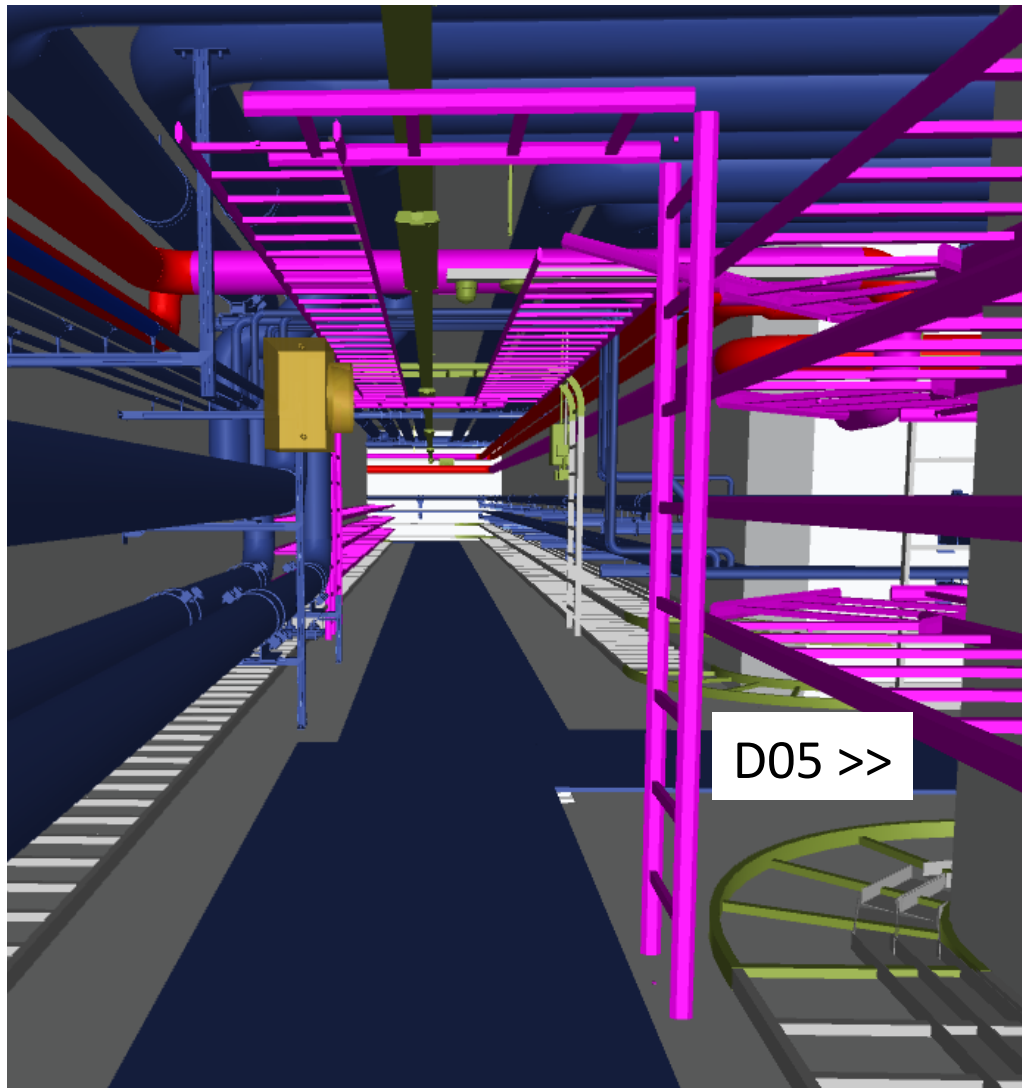

Integrated Planing for Cables / Cabinets

- **Coordination of cable routing and installation**
 - With the exception of detector cables, PSS and sensitive sample environment not all technologies need to be running in separate cable trays
 - Definition of cable classes (consolidation and separation of cables)
 - Coordination of routings from different technologies
- **Prepare cable installation**
 - Use of a 3D tool for planing (ePLAN 3D?, Aveva E3D?)
 - Produce cables/routing lists
 - Plans should be complete, comprehensive and clear for the installation teams
- **Same situation with control cabinets / racks**

Electrical Engineering – Example BIFROST

1. Electrical Power Distribution
2. Electrical Drawings (ePLAN package)
3. Integrated planning for cables and cable tray installations
4. Integrated planning for cabinets and racks

0.25 FTE of a draftsman for ePLAN to coordinate and compile the drawing package for BIFROST mainly in 2019. Budget: 27 kEUR

Staffing: ESS E&IS Division

0.5 FTE of an electrical engineer to coordinate the power needs, cable routings and installations on the instrument (0.1 FTE/y for a 5y period) Budget: 55 kEUR

Staffing: TBD, probably an Electrical Engineer in NSS

Thanks!

Any questions?