

# Neutron Bunker Installation plan

Antonio Bianchi

NSS Installation Co-ordinator

European Spallation Source ERIC

[www.europeanspallationsource.se](http://www.europeanspallationsource.se)

7<sup>th</sup> December 2017

According to the present Master Schedule v. 3.4, the Bunker installation will take place from December 2018 until October 2020, in order to be ready for B.o.T.

Main installation tasks include:

- 1 Drilling works;
- 2 Installation of Bunker frames structure (and instruments baseplates);
- 3 Installation of Bunker walls West/North sector (D03) (incl. some instr. feed-trough);
- 4 Installation of Bunker walls East/South sector (D01) (incl. some instr. feed-trough);
- 5 Installation of Bunker Roof -1st layer;
- 6 (In-Bunker instruments installation);
- 7 Installation Bunker roof 2nd and 3rd layers);
- 8 Installation of Utilities and PSS;

# Milestones and constraints

Several milestones and constraints have to be considered, due to the necessity to install the NMBEX tools (**T.D.**), in-Bunker components for three instruments (**IN KIND**) and T.B.L., the “D” Buildings Halls to be completed simultaneously (**CF/SKANSKA**)

Milestones (and constraints)	Date
Access to monolith area from T.D. for Bunker R6 structure inst.	Mon 19-01-21
D03 early access to bunker area	Mon 19-06-03
D01 early access to bunker area	Wed 19-08-14
D03 partial access to bunker area (including cranes)	Tue 19-08-13
D01 partial access to bunker area (including cranes)	Mon 19-10-28
Bunker wall-inserts delivered to the site (8 instr.)	Mon 19-06-03
Bunker ready for first In-Bunker instruments installation	Fri 19-11-15
In Bunker instruments installation done - close Bunker	Fri 20-05-15
<b>Bunker ready for B.o.T.</b>	<b>Tue 20-10-13</b>

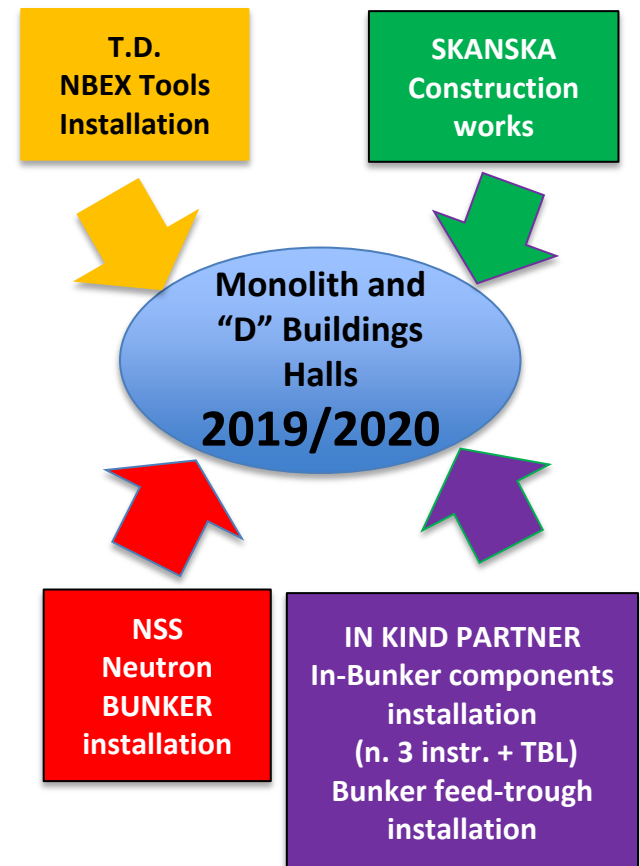

# Neutron Bunker installation - main tasks

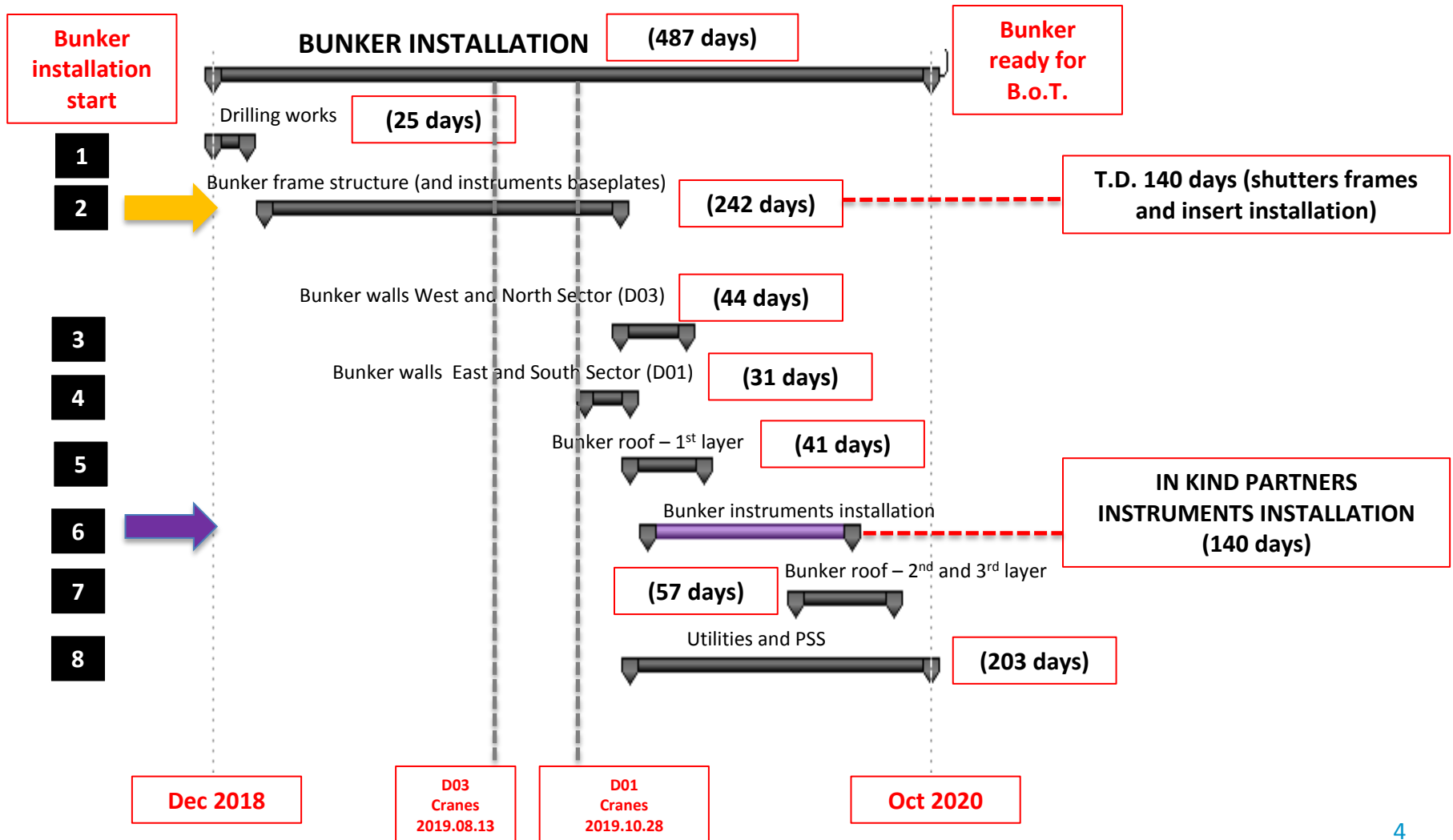

# 1. Pre-drilling works

Task	Area	Duration
pre drill holes for instruments steel baseplates	D02	15 days
Pre drill holes for bunker pillars (n. 332 holes)	D02	10 days

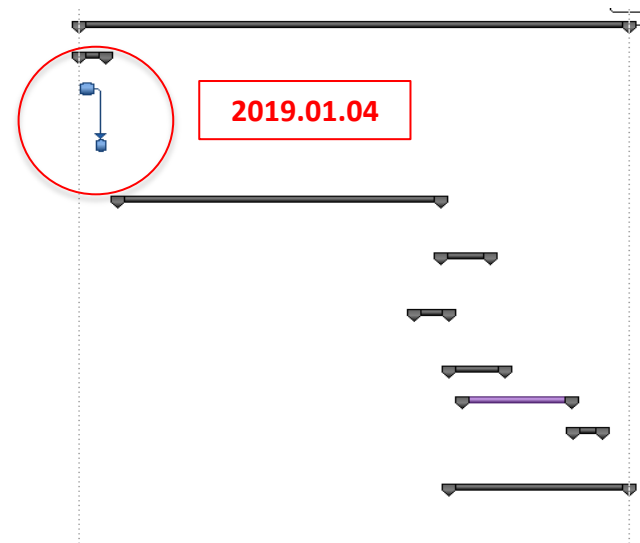
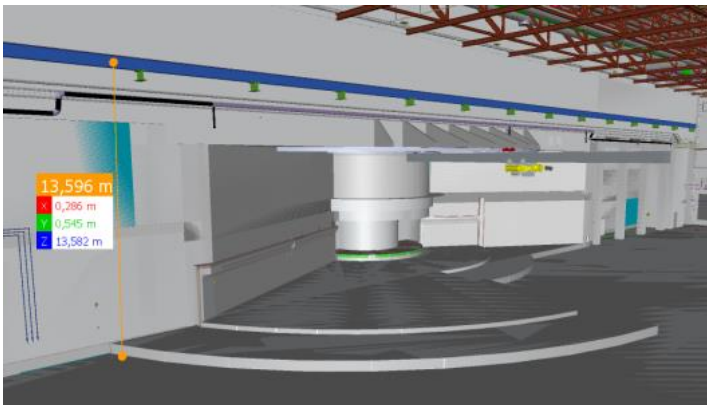
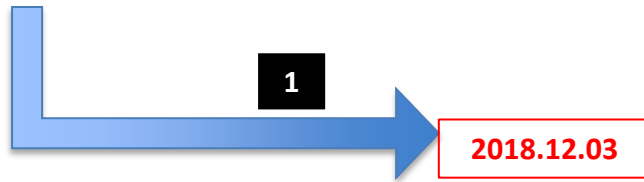

**NOTE:**  
D01 and D03 the bunker anchor plates to be installed from Skanska together with the slabs on-site cast (transfer of scope)

# 2. Bunker frame structure (and instruments baseplates)

Task	Area	Duration
<b>Installation of instruments baseplates and Bunker frames structure</b>		<b>242 days</b>
R6 weld-on brackets (n. 44)	D02	22 days
<b>Target activities (light shutter frames and rails) + grouts</b>	<b>D02</b>	<b>70 days</b>
R6 pillars (n. 44)	D02	8 days
R6 beams (n. 6)	D02	6 days
R6 Skirt shield blocks (n. 56 steel + 144 HDPA)	D02	10 days
Instruments baseplates D02 (D03 side) - n. 64 - 80 x 120 cm	D02/D03	20 days
Instruments baseplates D02 (D01 side) - n. 52 - 80 x 120 cm	D02/D01	16 days
Pillars baseplates D02 (D03 side) n. 19	D02/D03	5 days
Pillars baseplates D02 (D01 side) n. 19	D02/D01	5 days
<b>Target activities (insert installation)</b>	<b>D02</b>	<b>70 days</b>
Pillars, beams frames and wall brackets in D02 (D03 side) (n. 19+28+6)	D02/D03	20 days
Pillars, beams frames and wall brackets D02 (D01 side) (n. 19+28+6)	D02/D01	20 days
Pillars, beams and angular frames D03 (36+55+7)	D03	32 days
Pillars, beams and angular frames D01 (n.9+13+2)	D01	8 days

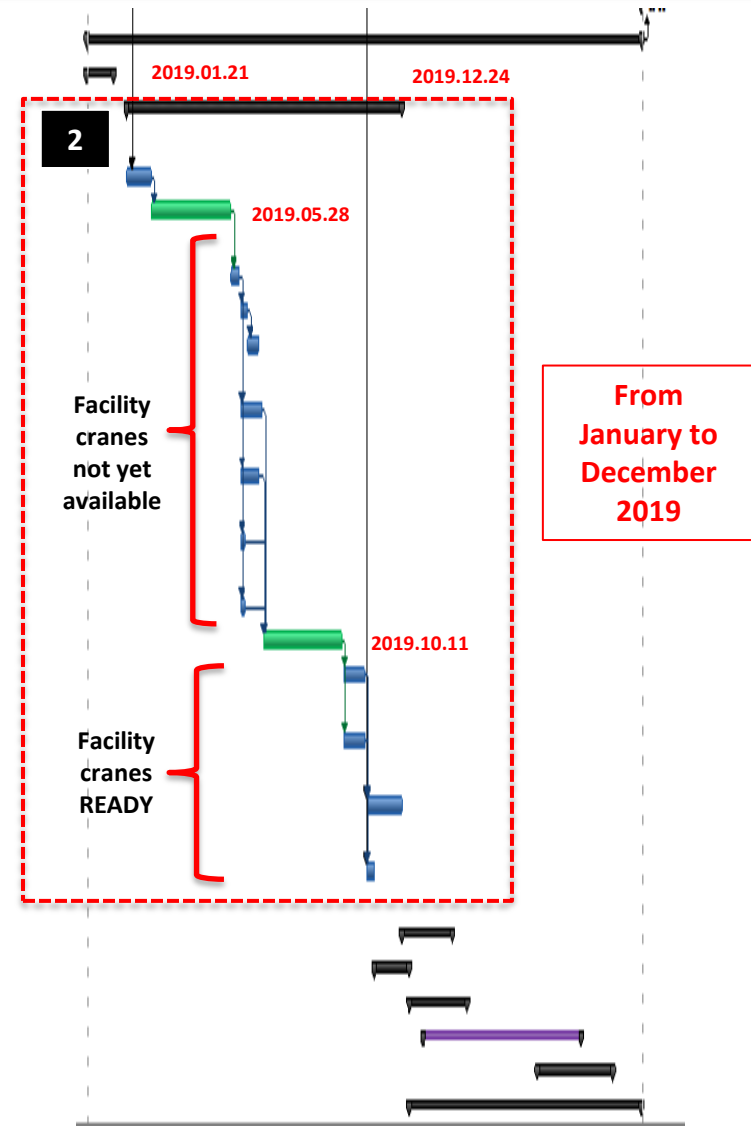

# Steel-Frame installation sequence

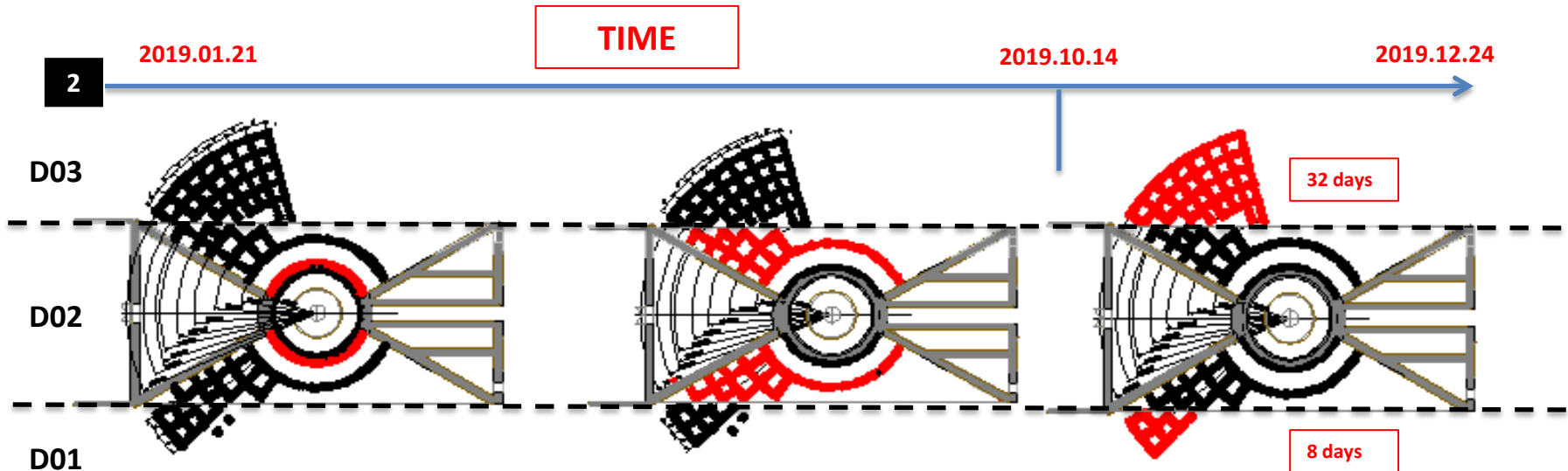

**Assumptions:**

R6 brackets: 1 day/port  
 R6 pillars: 3 hours/pillar  
 R6 beams: 2 days/beam

**Assumptions:**

Pillars baseplates: n.4/day  
 Pillars, beams, wall brack.:  
 2,6 h/item

**Assumptions:**

Pillars, beams, wall brack.:  
 2,6 h/item

**A TEAM FOR EACH SIDE REQUIRED  
 TO PROGRESS IN PARALLEL**

**NOTE 1**

Pillars baseplates in D01 and D03 already installed from Skanska.

**NOTE 2**

D02 baseplates to be installed with temporary lifting equipment

D03 partial access to bunker area (including cranes) Tue 19-08-13

D01 partial access to bunker area (including cranes) Mon 19-10-28

# 3. Bunker walls (D02 and D03 sectors)

Task	Area	Duration
<b>Installation of Bunker walls West/North sector (D03)</b>		<b>44 days</b>
North sector wall in D02 (D03 side) short sector n. 51 full spec + 39 concrete	D02/D03	18 days
Side wall D03 - 54 blocks	D03	7 days
West sector wall (D03) - long sector n. 136 full spec. + 16 concrete	D03	19 days

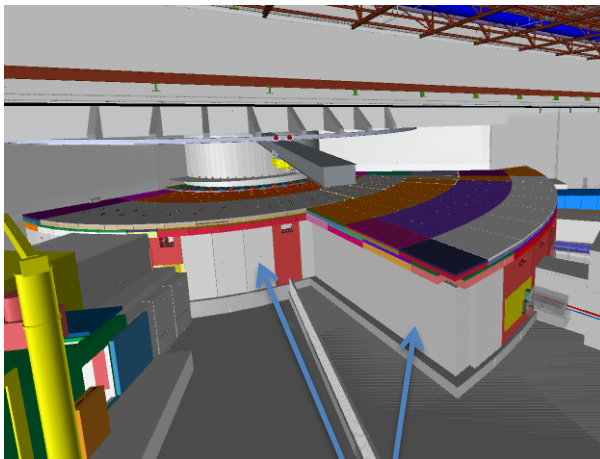

**Bunker wall  
D03/D02**

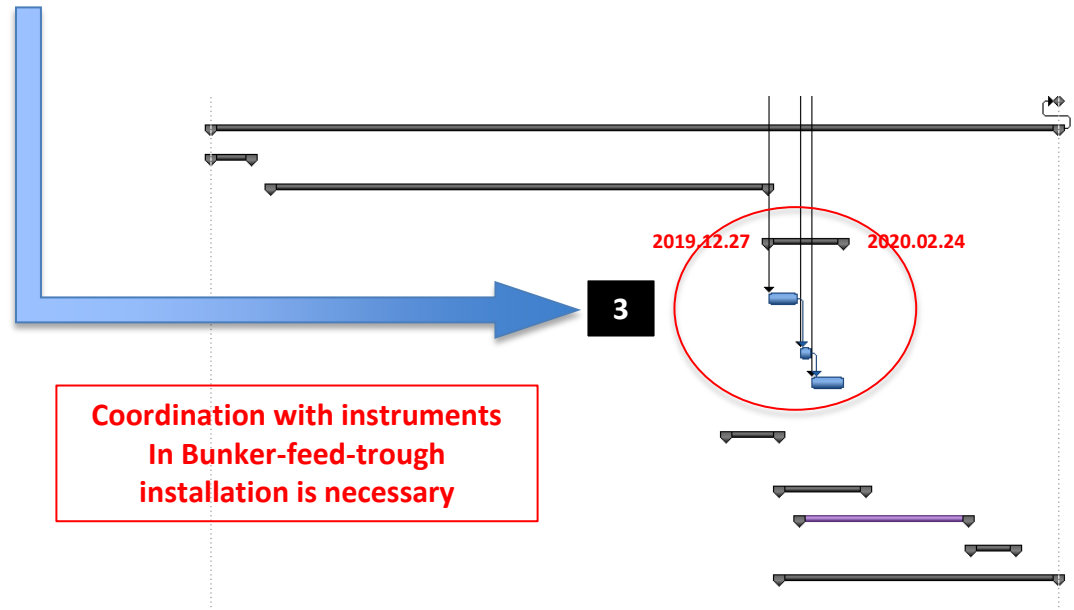

**Coordination with instruments  
In Bunker-feed-trough  
installation is necessary**



# Bunker-wall installation sequence (West/North sector)

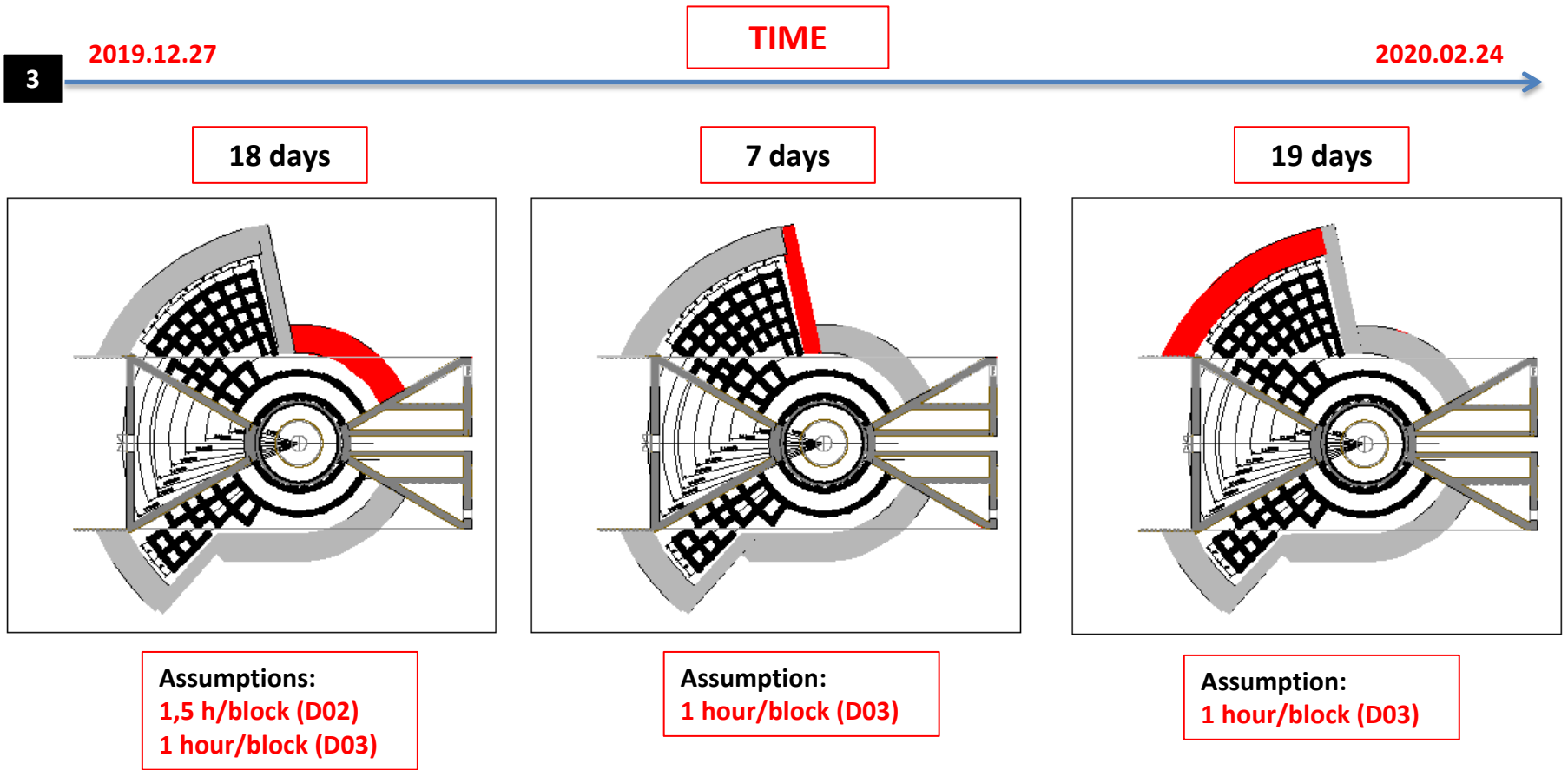

# 4. Bunker walls (D02 and D01 sectors)

Task	Area	Duration
<b>Installation of Bunker walls East/South sector (D01)</b>		<b>31 days</b>
East sector wall D02 (D01 side) 21 full spec + 72 concrete	D02/D01	18 days
Side wall D01 (n. 42)	D01	5 days
South sector - D01 wall - long sector (34 full spec + 25 concrete)	D01	8 days

**ASSUMPTIONS**  
**1,5 h/block (D02)**  
**1 h /block (D01)**

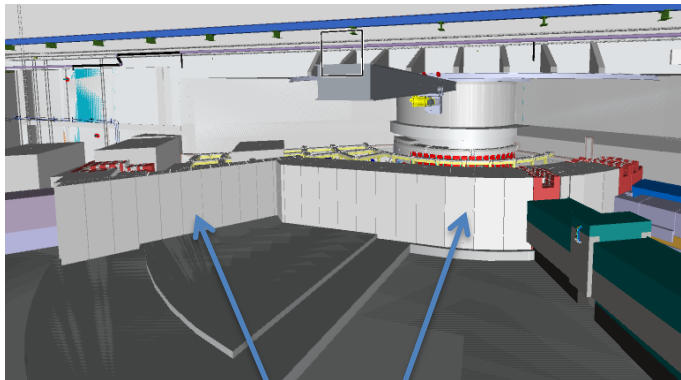

**Bunker walls  
D01/D02**

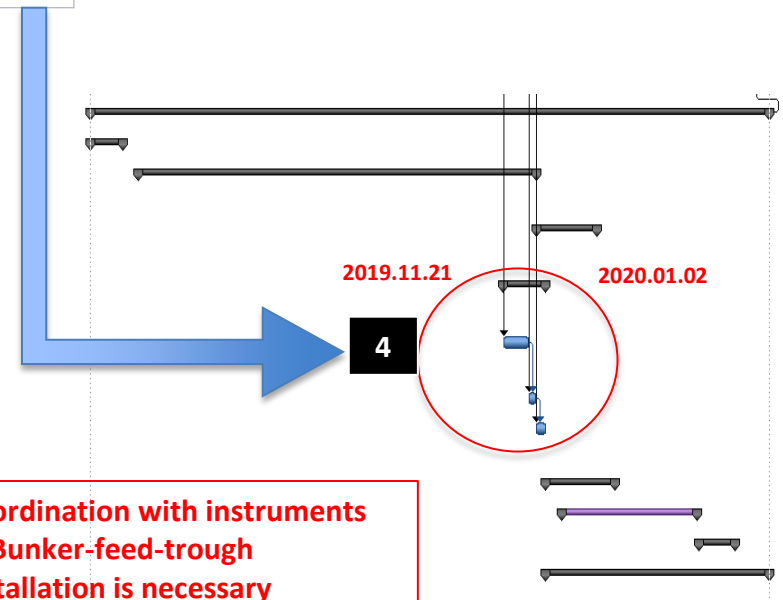

# Bunker wall installation sequence (South/East sector)

**TIME**

2019.12.05

2020.01.16

4

18 days

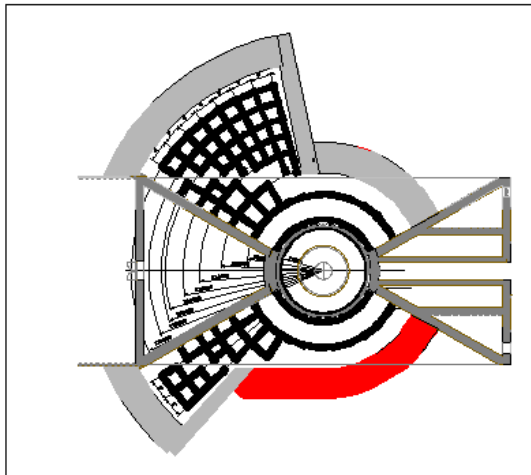

**Assumptions:**

**1,5 h/block (D02)**

**1 hour/block (D01)**

5 days

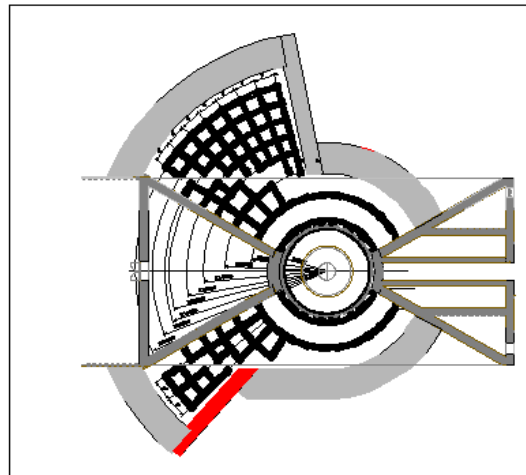

**Assumption:**

**1 hour/block (D01)**

8 days

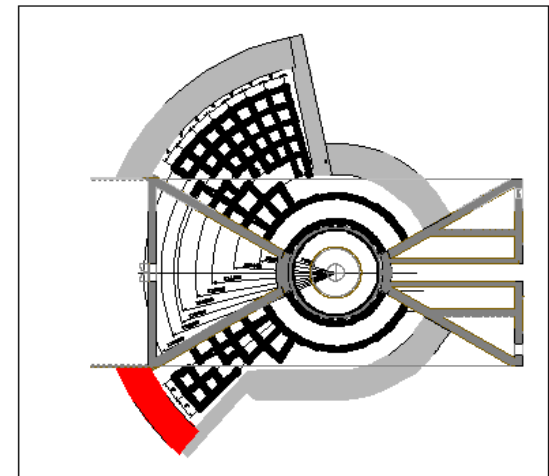

**Assumption:**

**1 hour/block (D01)**

# 5. Bunker roof (1st layer)

Task	Area	Duration
<b>Installation of Bunker Roof -1st layer</b>		<b>51 days</b>
Bunker roof - 1st layer D02 (D03 side) and D03 - (43+ 44 blocks)	D02/D03	14 days
Bunker roof - 1st layer D02 (D01 side) and D01 n. (48 + 15 blocks)	D02/D01	11 days

**ASSUMPTIONS**  
 1,5 h/block (D02)  
 1 h /block (D01)

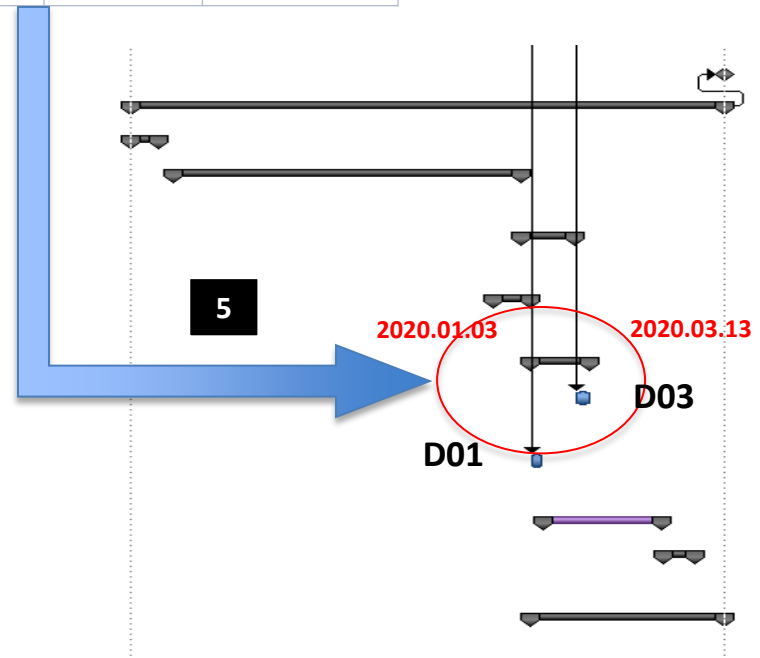
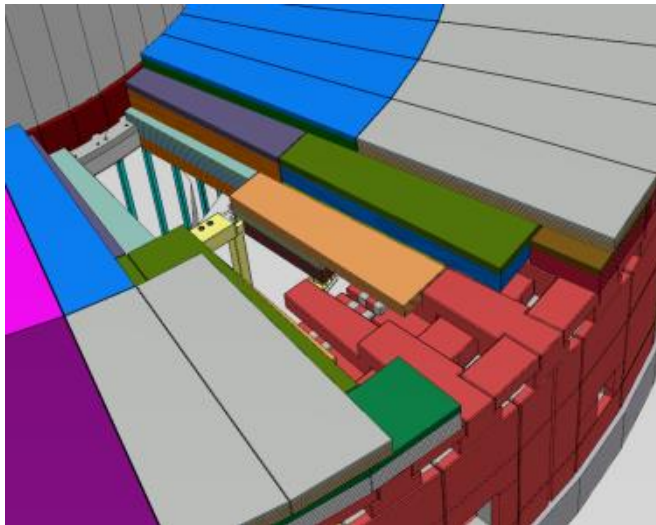

# Bunker roof installation sequence (1st layer)

TIME

2020.01.03

2020.03.13

5

11 days

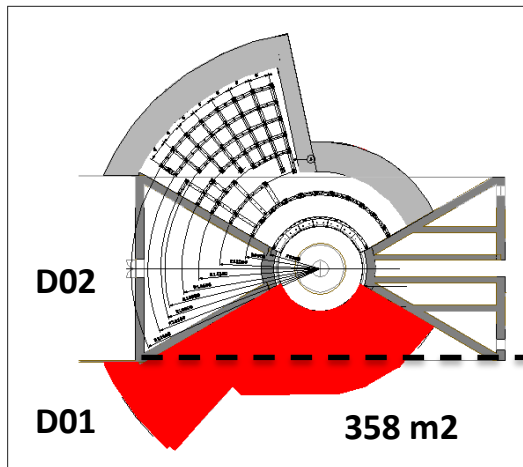

Assumptions:

1,5 h/block (D02)

1 hour/block (D01)

14 days

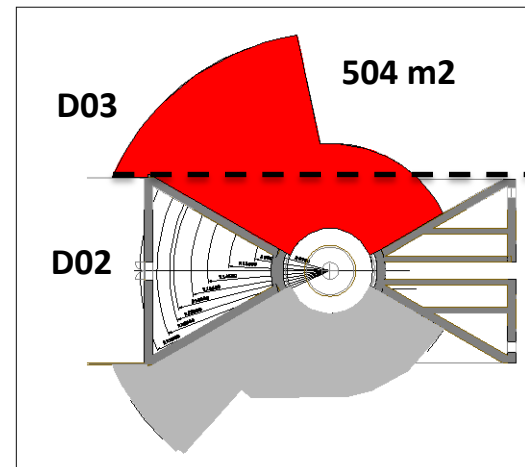

Assumptions:

1,5 h/block (D02)

1 hour/block (D03)

# 6. Instruments in-Bunker components installation

Task	Area	Duration
<b>In-Bunker instruments installation</b>		<b>140 days</b>
In Bunker-components instruments installation (D03)	D02/D03	100 days
In Bunker-components Instruments into (D01)	D02/D01	100 days

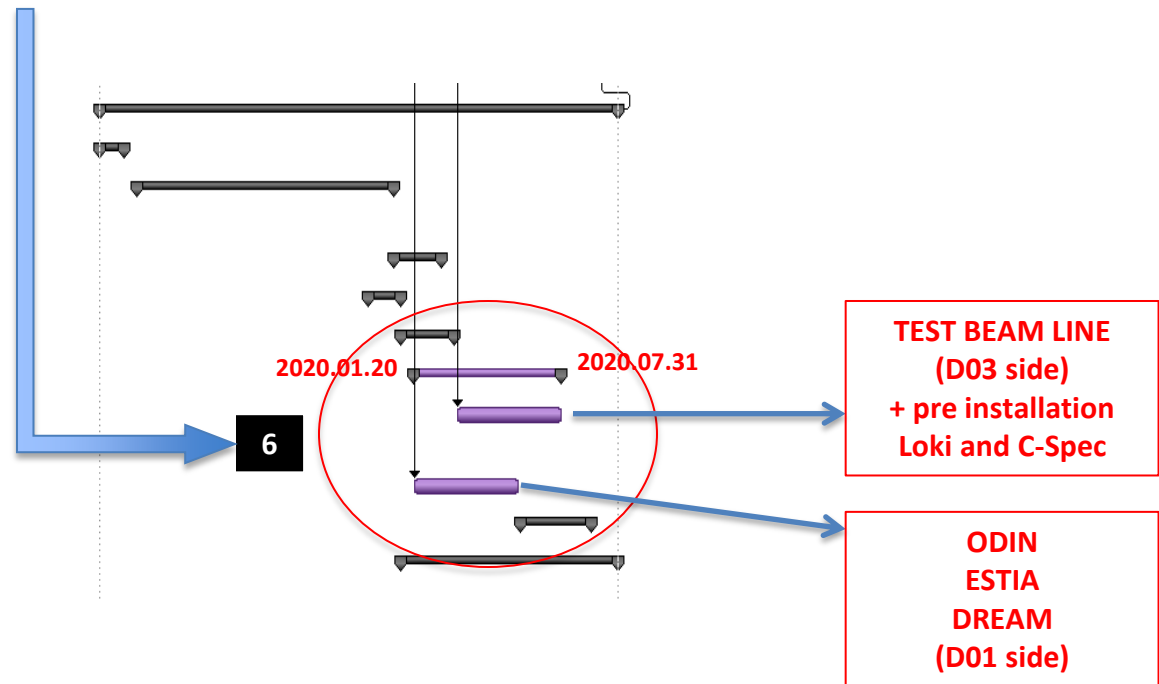

# 7. Bunker roof (2<sup>nd</sup> and 3<sup>rd</sup> layer)

Task Name	Area	Duration
<b>Installation Bunker roof 2nd and 3rd layers)</b>		<b>67 days</b>
Bunker roof - 2nd and 3rd layer D02 (D03 side) and D03 (n. 84 + 88 blocks)	D02/D03	27 days
Bunker roof - 2nd and 3rd layer D02 (D01 side) and D01 - (n. 96 +30 blocks)	D02/D01	22 days

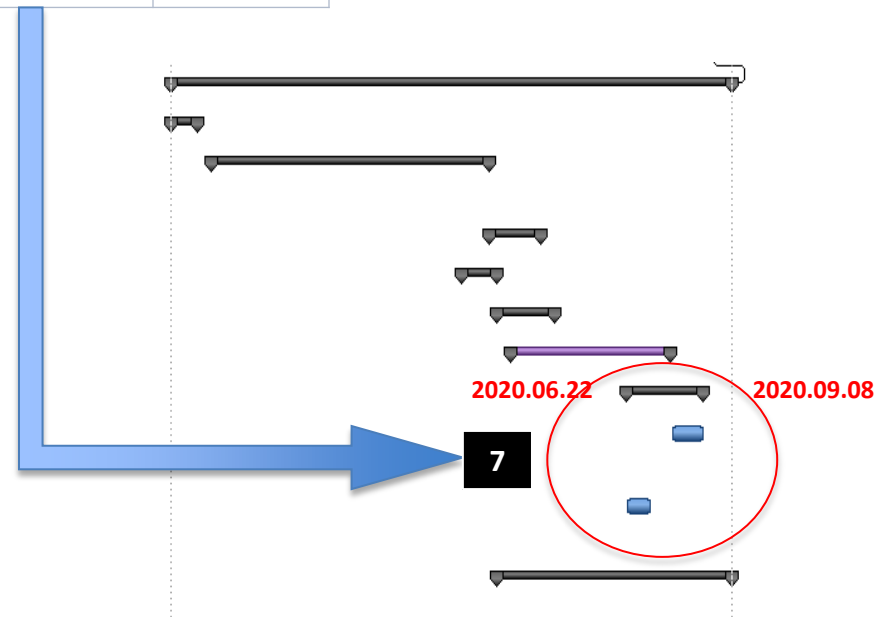
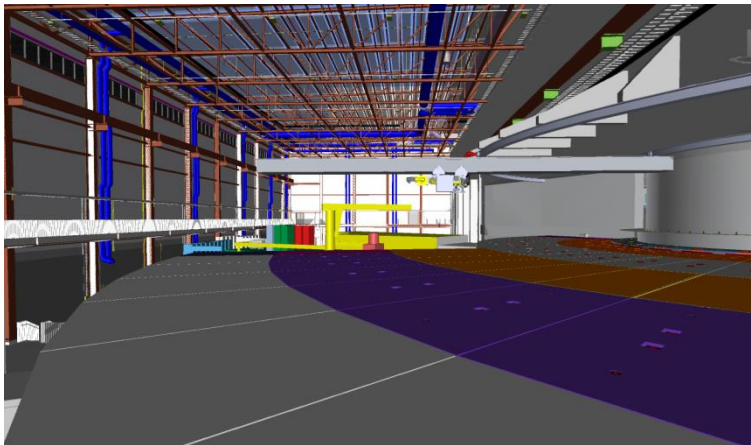

# Bunker roof installation sequence (2<sup>nd</sup> and 3<sup>rd</sup> layer)

7

2020.06.22

TIME

2020.09.08

22 days

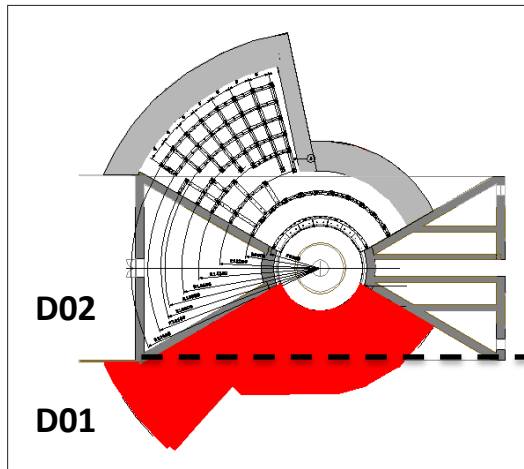

**Assumptions:**

1,5 h/block (D02)  
1 hour/block (D01)

27 days

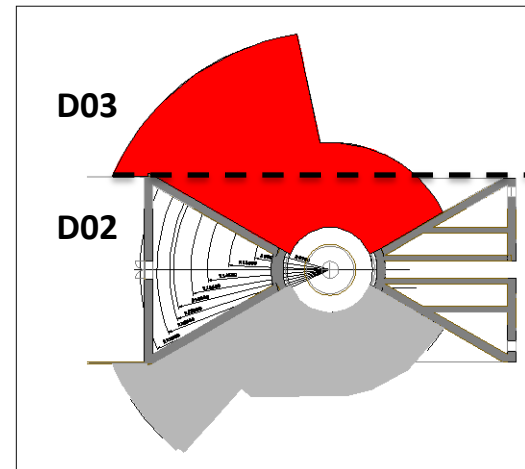

**Assumptions:**

1,5 h/block (D02)  
1 hour/block (D03)



# 8. Installation of Utilities and PSS

Task	Area	Duration
<b>Installation of Utilities and PSS</b>		<b>203 days</b>
Utilities installation D02 (D03 side) and D03	D02/D03	7 days
Utilities installation D02 (D01 side) and D01	D02/D01	7 days
Installation of PSS on top of the Bunker roof D02 (D03 side) and D03	D02/D03	15 days
Installation of PSS on top of the Bunker roof D02 (D01 side) and D01	D02/D01	15 days
PSS commissioning before BoT		10 days

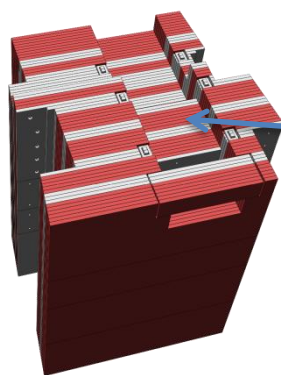
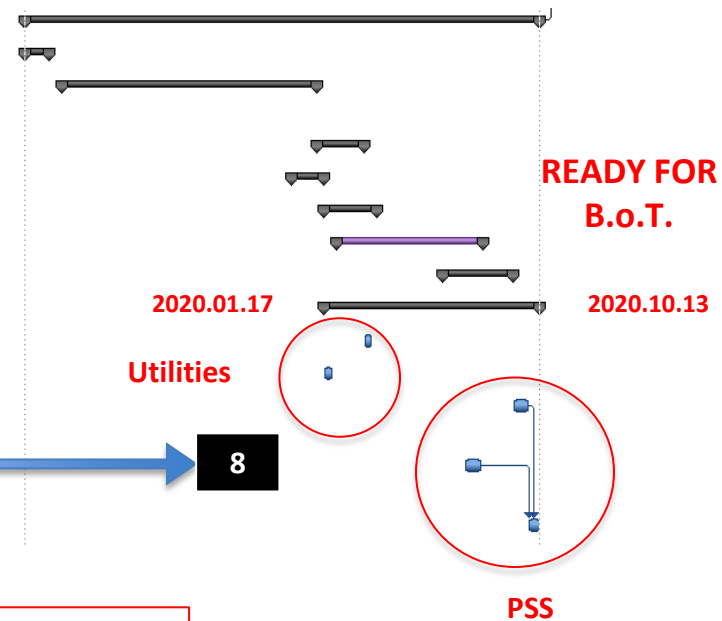

Instruments utility to be placed in parallel with wall installation at least for the first 3 instruments

PSS on top of the roof

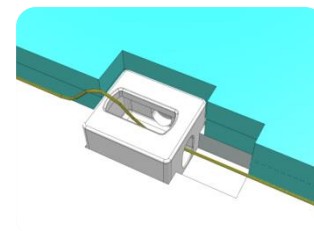
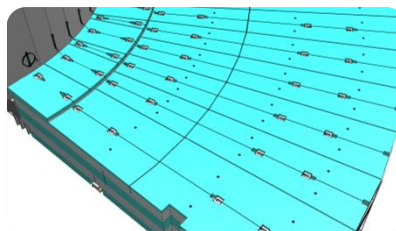

# Bunker-crane hook-print (5 ton and 20 ton capacity)

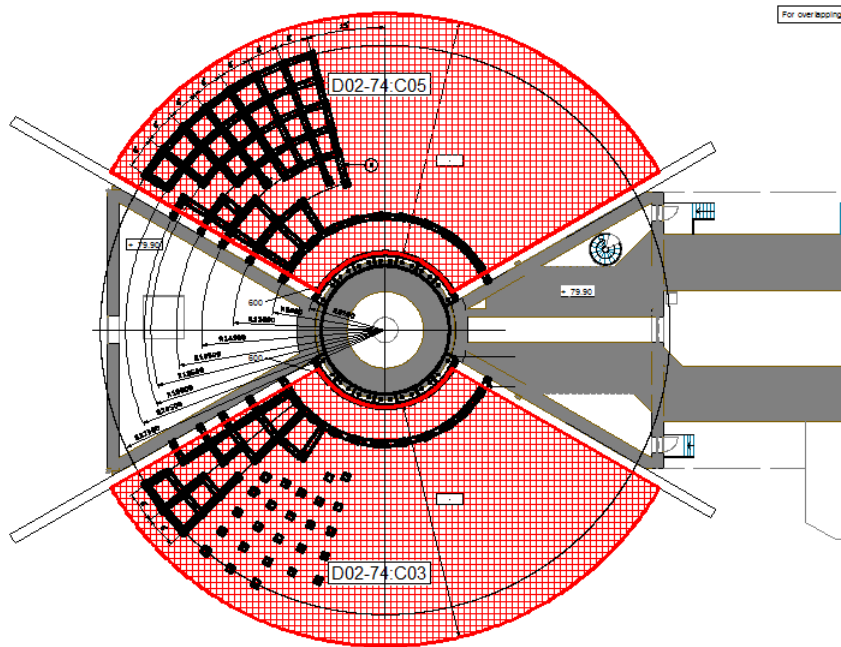

20 ton load capacity

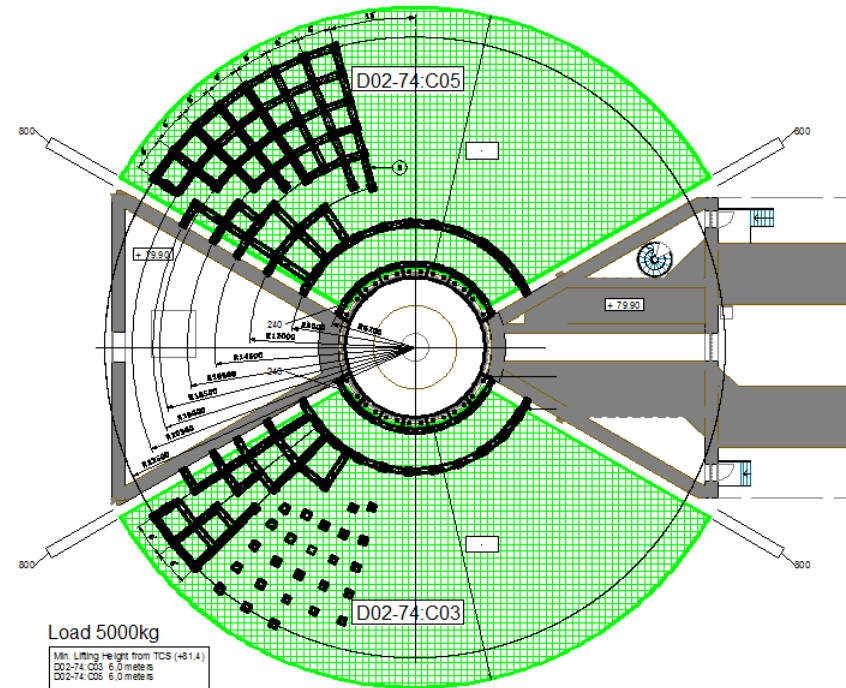

5 ton load capacity

# R6 beams installation with temporary equipment

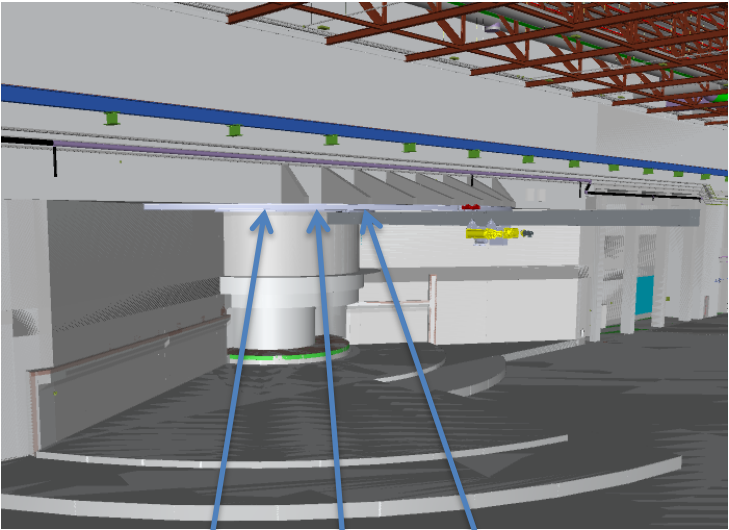

Tri-lifter

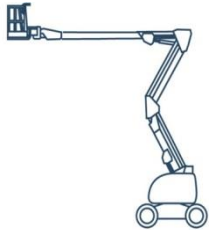

Boom lift

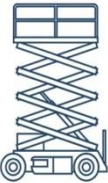

Scissor Lift

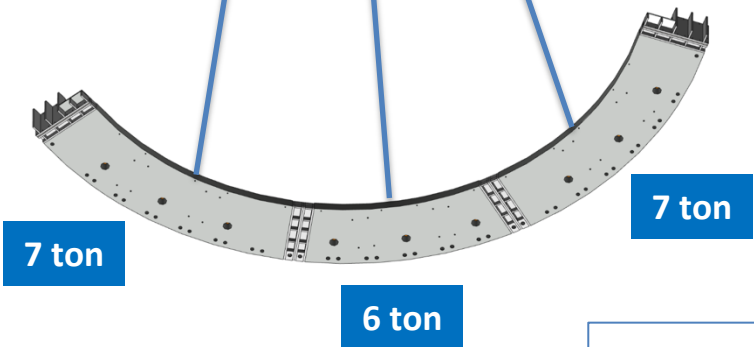

n. 3+3 R6 beams

20 ton Crane Hook-print

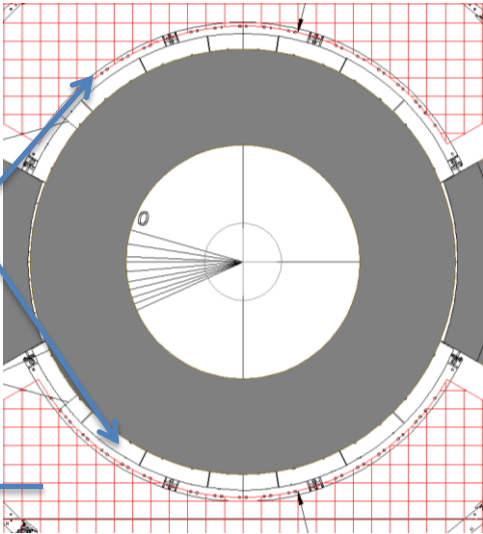

# Steel-Frames installation in case of cranes unavailability



Steel-frame structure

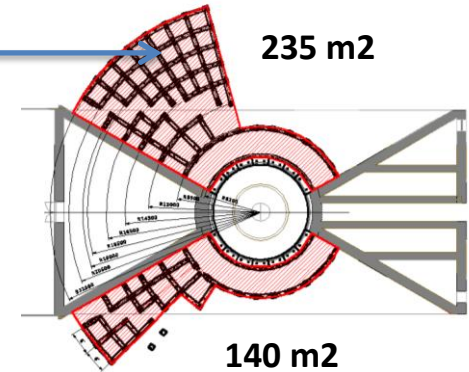
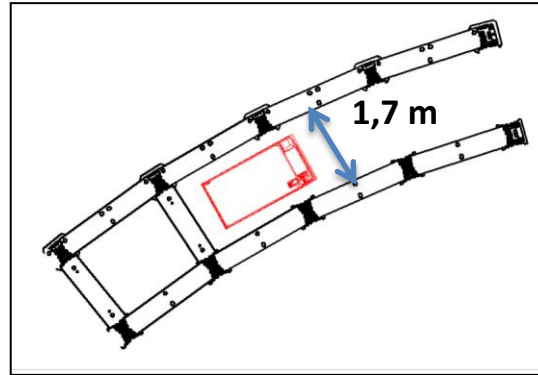

Electric mobile crane 4 ton

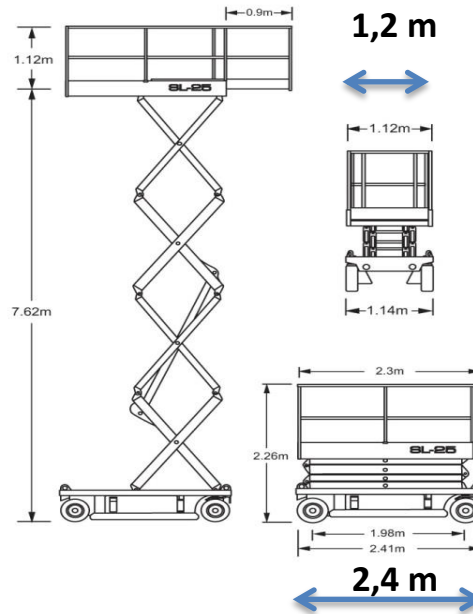

Electric scissor lift

# Bunker walls – area not covered from crane hook-print

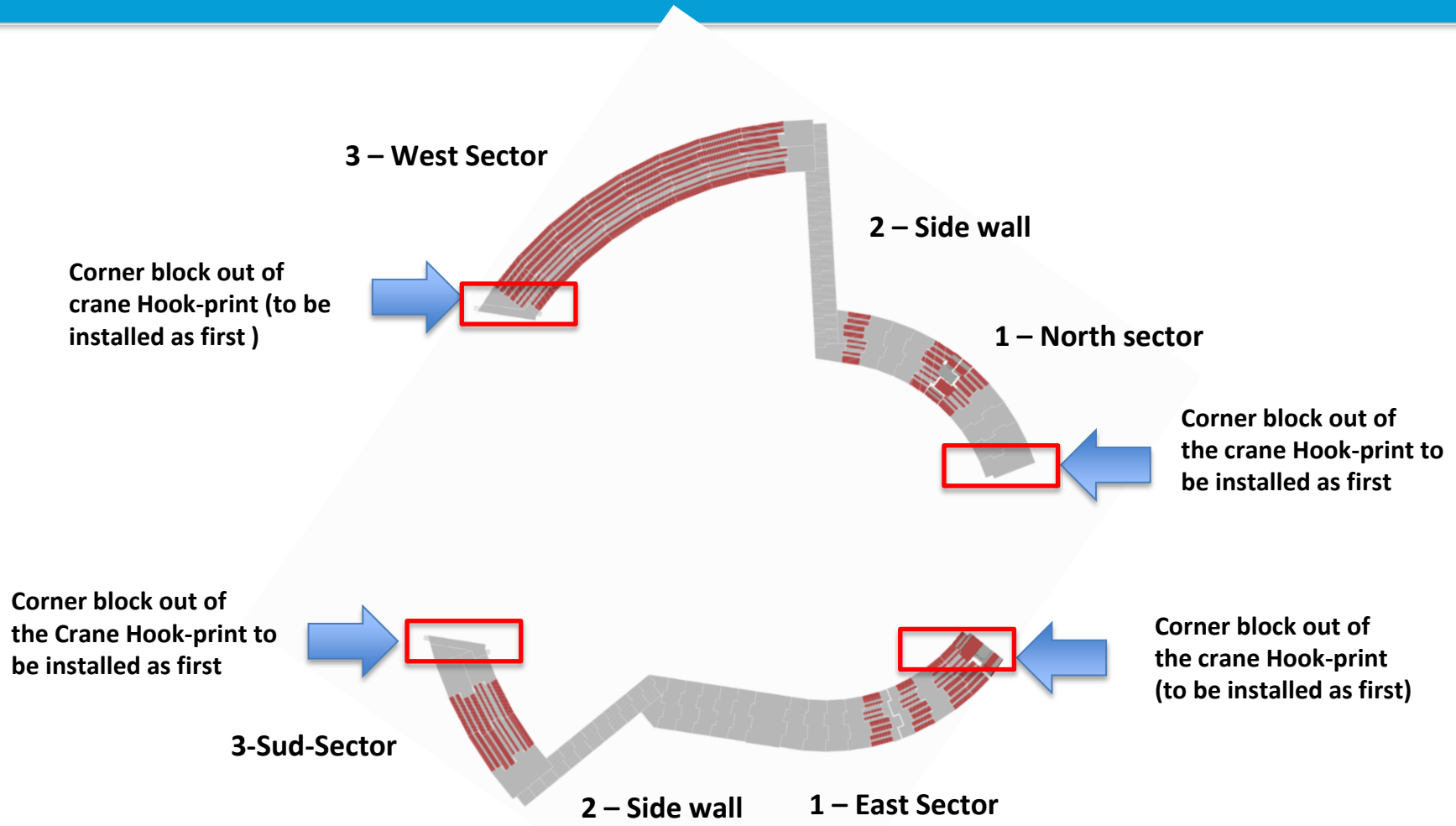

# Overlap between Bunker-crane hook-print and bunker walls

D03 Experimental-hall  
crane required

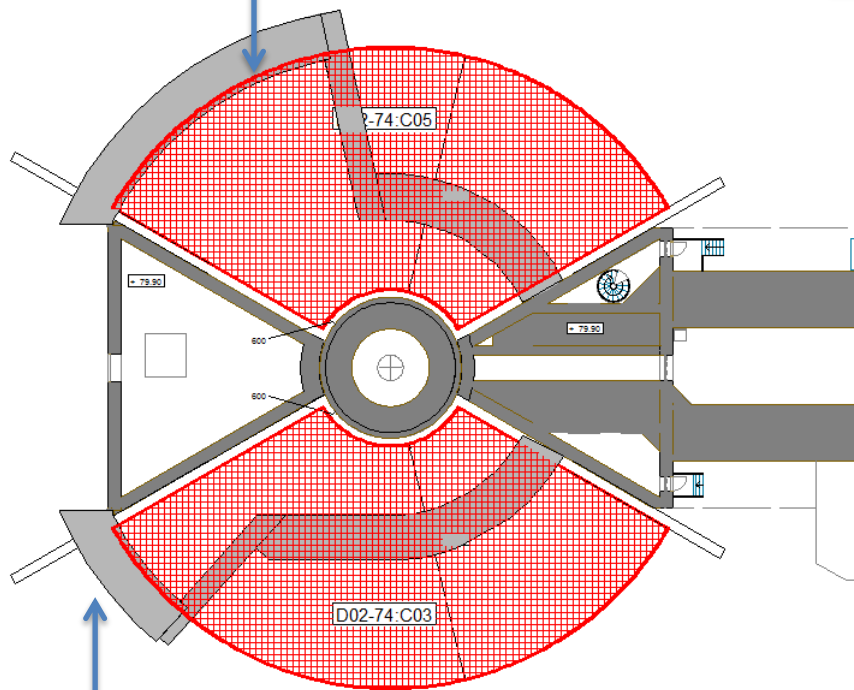

D01 Experimental-hall  
crane required

D03 Experimental-hall  
crane required

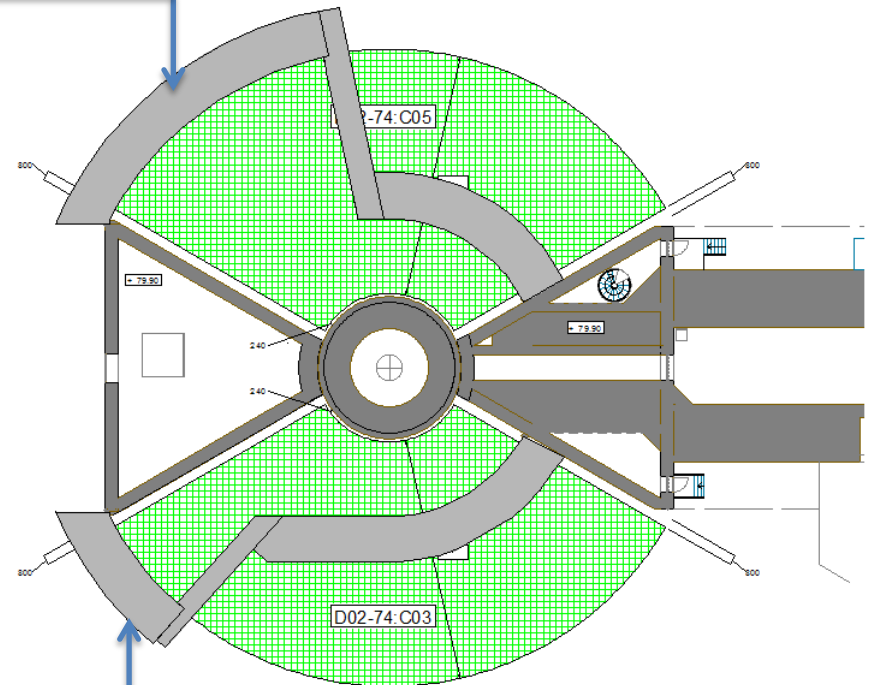

D01 Experimental-hall  
crane required

# Overlap between D01/D03 Halls-cranes hook-print and bunker walls

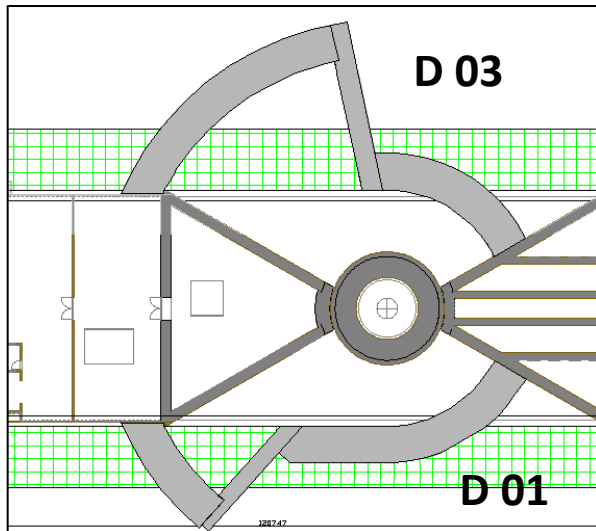

**Layout based on CF Cranes preliminary drawings**

**5 ton**

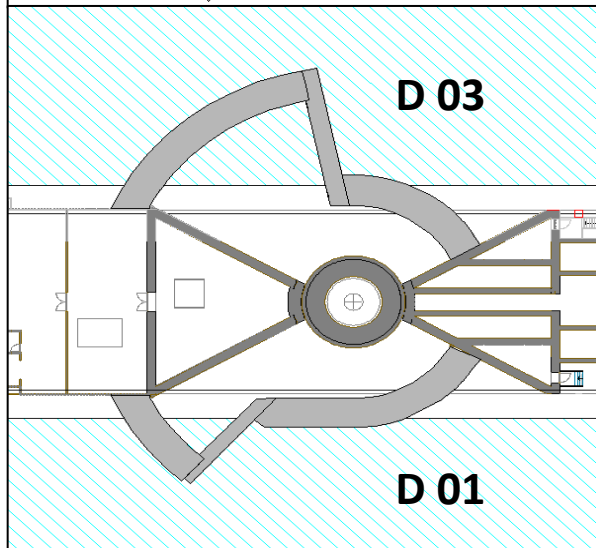

**7,5 ton**

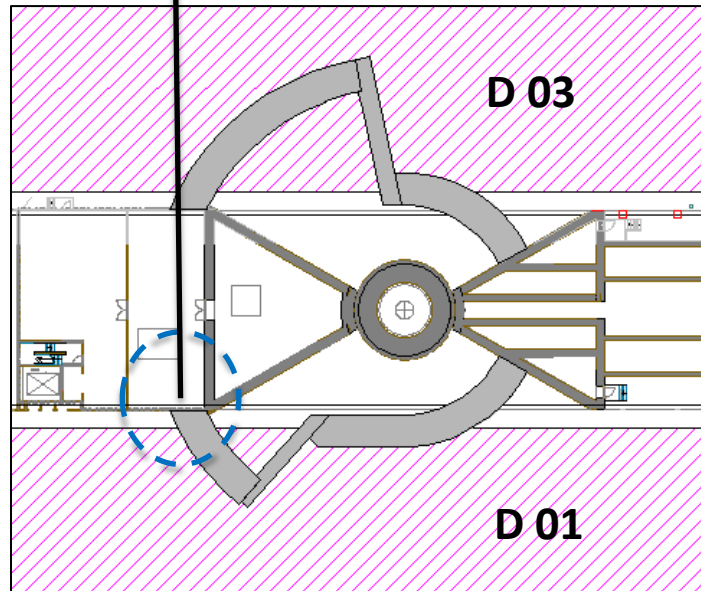
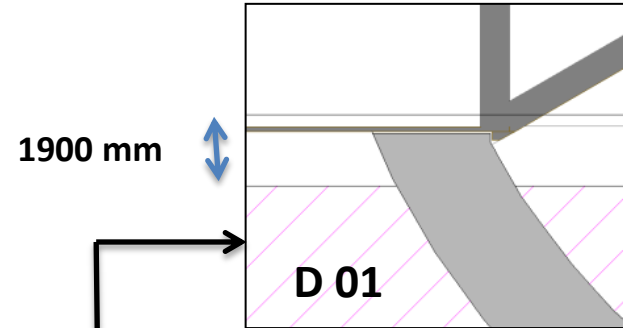

**30 ton**

# Alternative Lifting-tools to spreader -bar

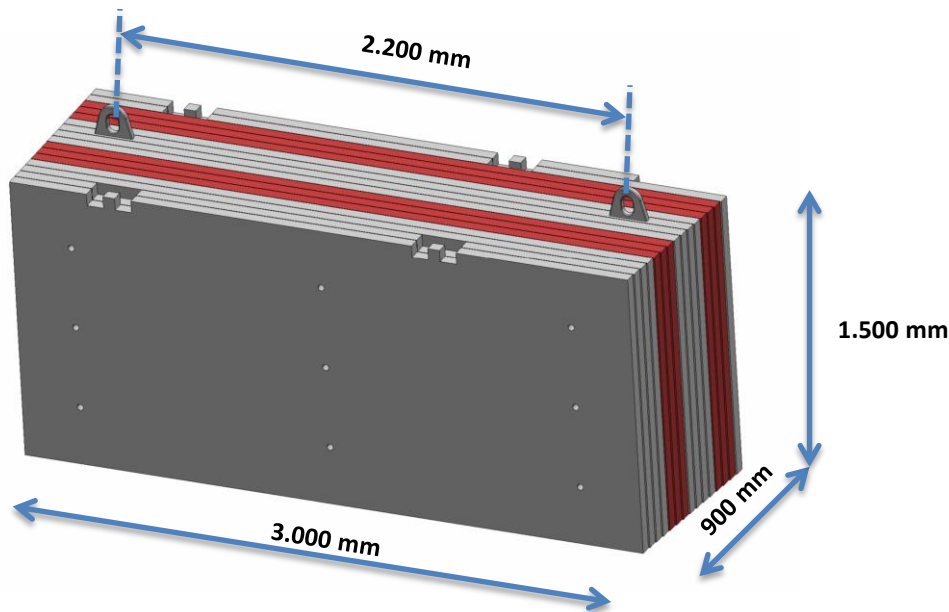

Blocks lifting eyes. 25mm steel  
Hook-hole is 50 mm wide and 80 mm high.

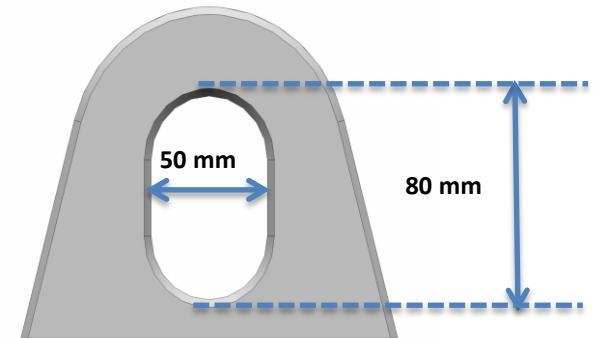

Bow-shackle  
W.L.L. 13,5 ton

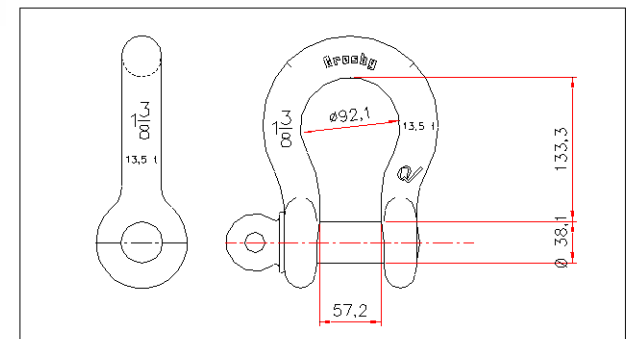

**Blocks size :** 900 - 3.000 mm wide  
Up to approx. 15.000 mm high  
Wight up to 14.000Kg

Distance between the eyes is 2.200mm (R28 wall).

**Specific spreader bars will be designed to lift walls and roof blocks, but ordinary lifting tools are also compatible**



# Walls lifting alternative to the spreader bar

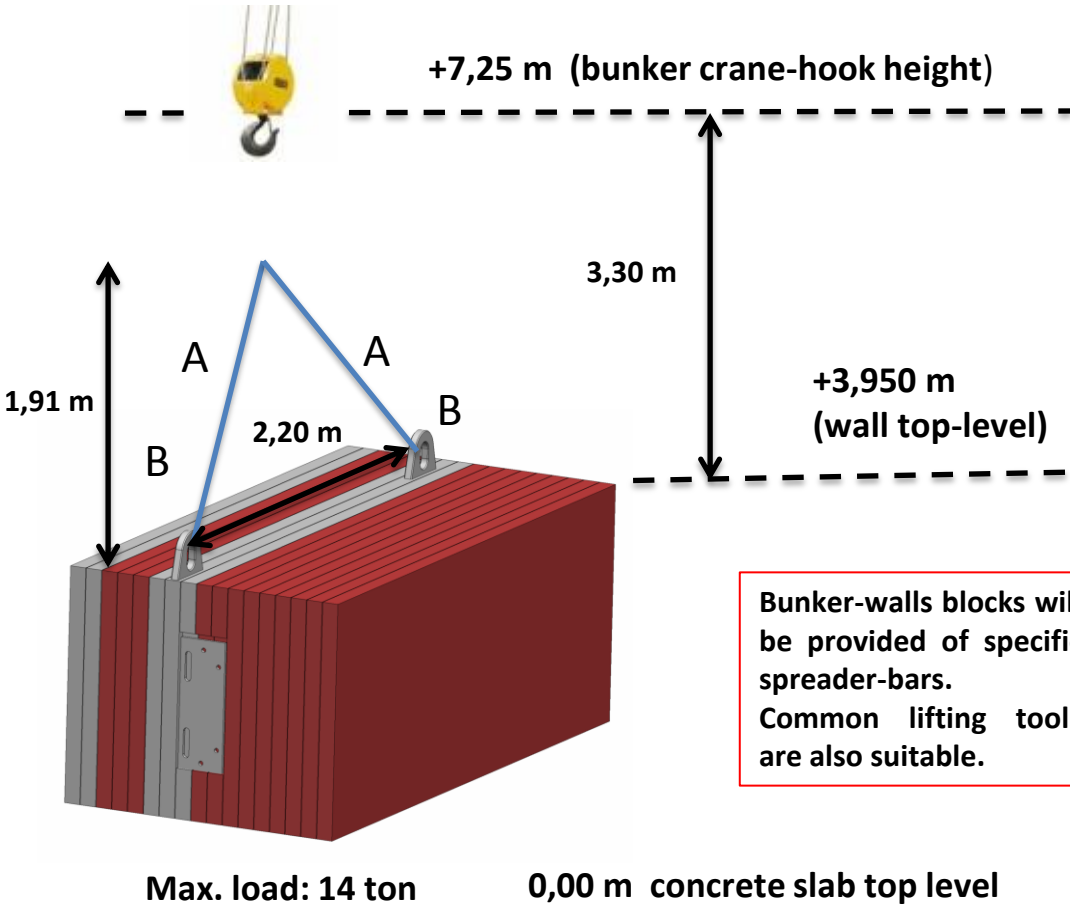

Bunker-walls blocks will be provided of specific spreader-bars. Common lifting tools are also suitable.

### Lifting tools

Load per sling: 8,2 ton

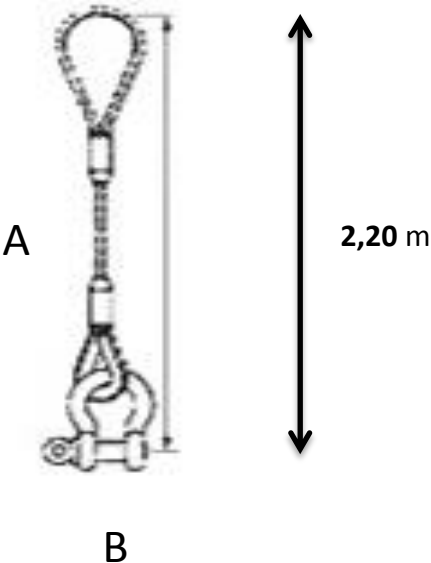

A

2,20 m

B

A: Rope sling W.L.L. 13,5 ton

B: Bow-shackle W.L.L. 13,5 ton

# Logistic: n. 4 lay-down zones

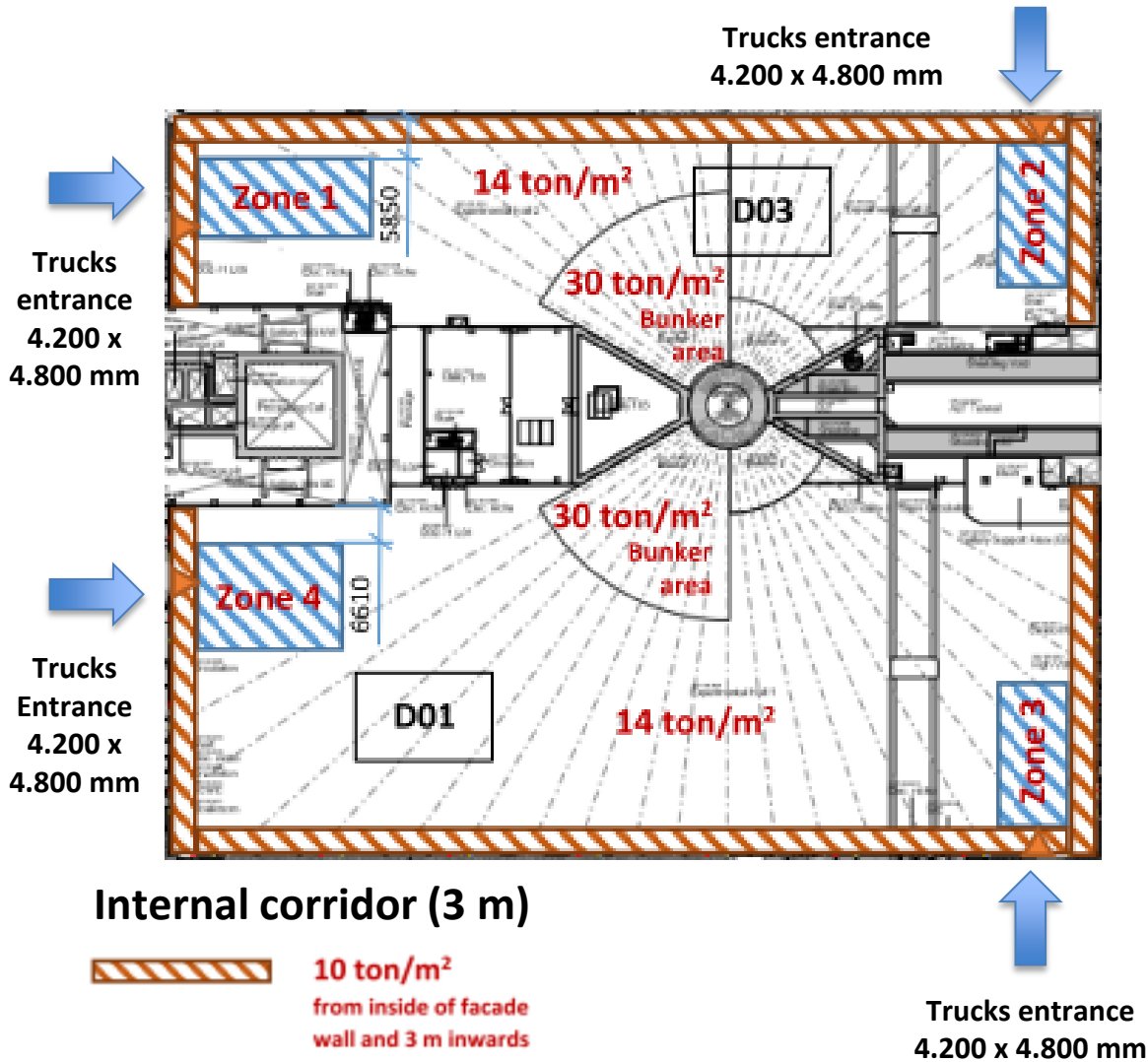

## Blocks lay-down area



- 20 ton/m<sup>2</sup>**
- Zone 1: 25 x 12 m<sup>2</sup>
- Zone 2: 20 x 10 m<sup>2</sup>
- Zone 3: 20 x 10 m<sup>2</sup>
- Zone 4: 20 x 15 m<sup>2</sup>
- placed 3 m from the inside of the facade wall with the gateway ▲



**10 ton capacity**  
**ALL AREAS**

# Logistic inside buildings



TO BE AGREED WITH  
CF/SKANSKA

Section view

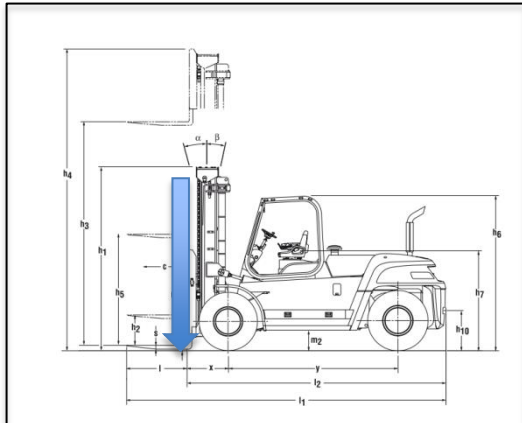
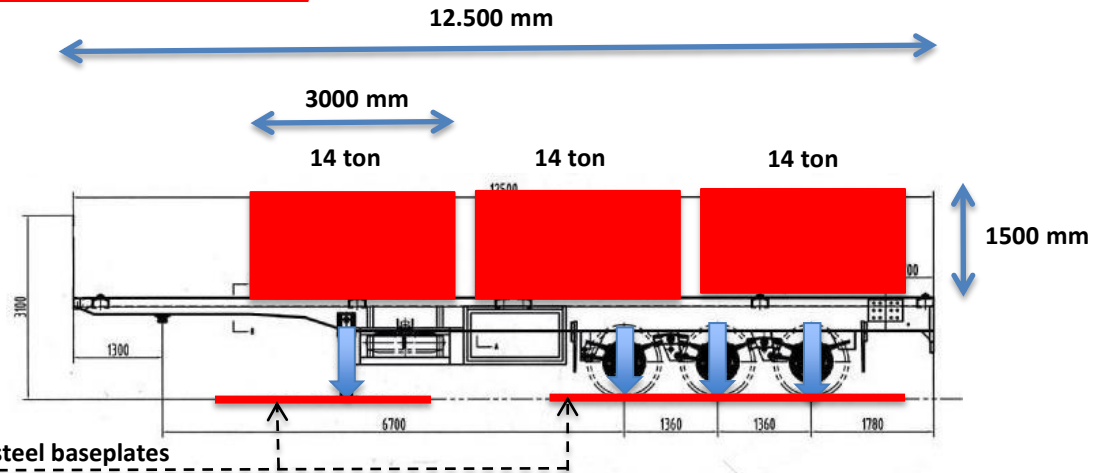

10 ton forklift capacity



Requirement  
 $15+10 = 25$  ton  
axle load

Slab load capacity: 14 ton/m<sup>2</sup>

Plan view



3-axes flatbed trailer: 50 ton payload (+ 6,5 ton dead weight)

# Walls installation trough mobile crane (alternative solution in D01/D03 for Halls cranes unavailability)

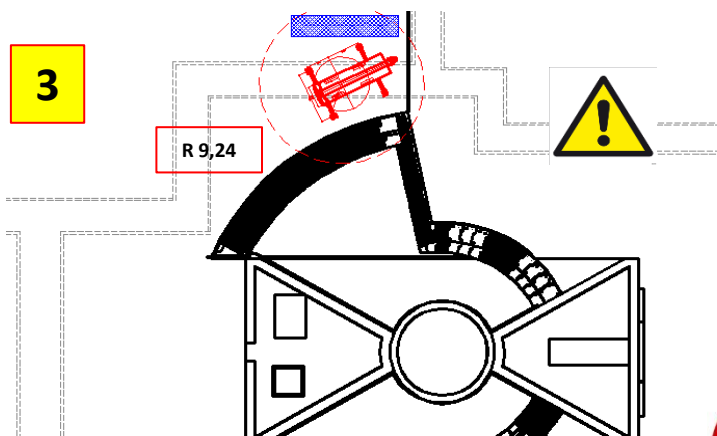
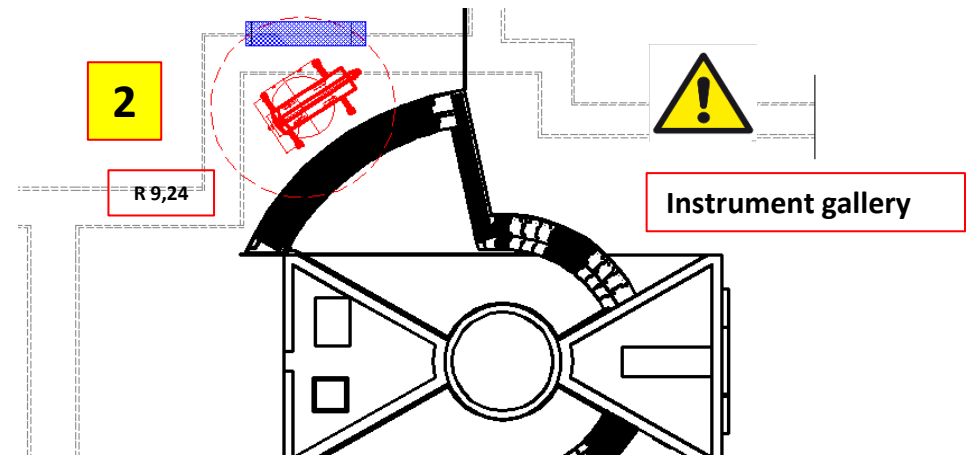
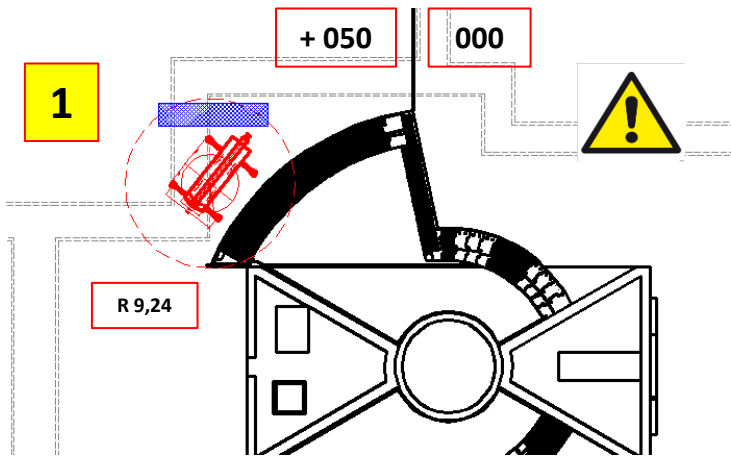

3-axle flatbed trailer

Mobile crane 35 ton

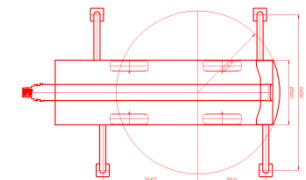
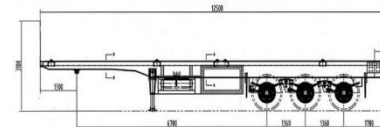

TO BE AGREED  
WITH  
CF/SKANSKA

NOTE: TO EVALUATE IN CASE OF HALL  
CRANE UNAVAILABILITY

# Temporary steel-frames for roof support of the instrument-gallery

HDS 90, Alu (11.20 kg)  
HDSS 90, Steel (28.20 kg)

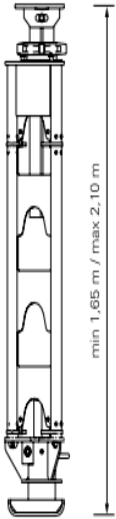

min 1.65 m / max 2.10 m

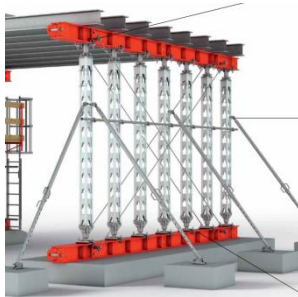

**PERI HD 200  
SYSTEM  
FOR  
TEMPORARY  
SUPPORT OF  
INSTRUMENT-  
GALLERY ROOF**

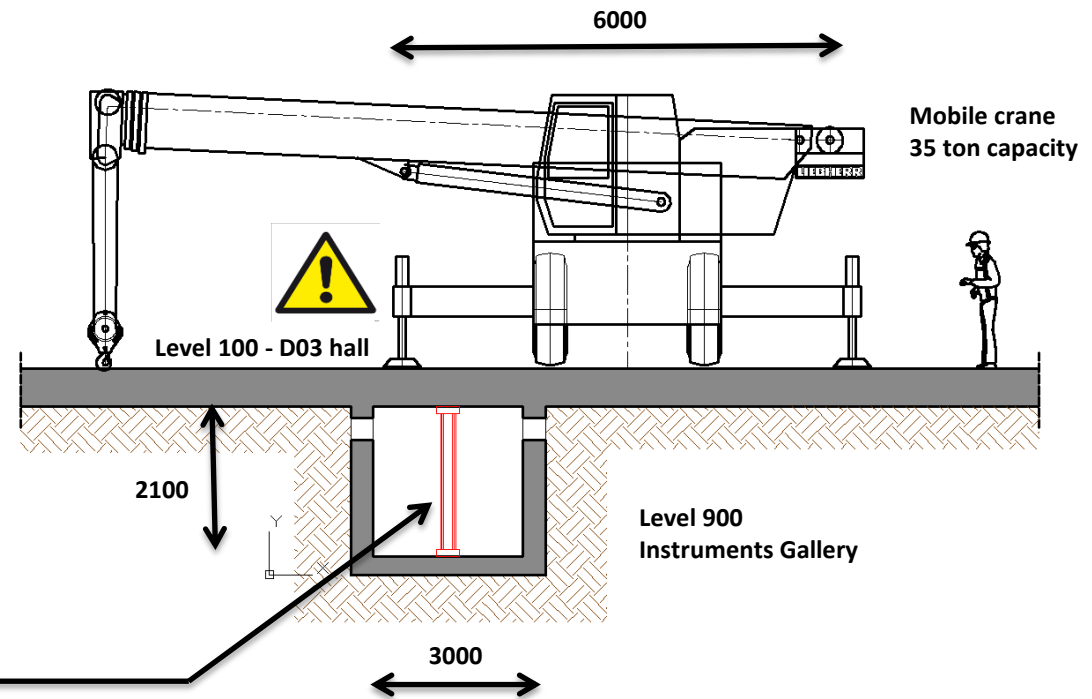

**TO BE AGREED  
WITH  
CF/SKANSKA**

# Resource plan: drilling works

n.	TASK description	Area	Days	Resources (Labour)						Total	Team	Note
				Tech (Crane)	Tech (Rig)	Tech (Han)	Tech Mech	Eng (Metrol.)	Tech Electr	Labour	n.	
1	2	3	4	5	6	7	8	9	10	11	12	13

1	Drilling works											
1.1	Pre drill holes for bunker pillars (n. 332 holes)	D02	10	0	0	1	3	0,3	0	4,3	2	Forklift for each team required

# Resource plan: steel frames structure

n.	TASK description	Area	Days	Resources (Labour)						Total	Team	Note
				Tech (Crane)	Tech (Rig)	Tech (Han)	Tech Mech	Eng (Metrol.)	Tech Electr	Labour	n.	
1	2	3	4	5	6	7	8	9	10	11	12	13

2	Installation of Bunker frames structure											
2.1	R6 weld-on brackets (n. 44)	D02	22	0	0	1	3	0,5	0	4,5	2	Forklift and boom lift for each team required.
2.2	R6 pillars (n. 44)	D02	8	0	0	1	3	0,5	0	4,5	2	Forklift and boom lift for each team required.
2.3	R6 beams (n. 6)	D02	6	0	0	1	3	0,5	0	4,5	2	Forklift and boom lift for each team and Temporary lifting equipment required
2.4	R6 Skirt shield blocks (n. 56 steel + 144 HDPa)	D02	10	0	0	1	3	0,5	0	4,5	2	Forklift and boom lift for each team and Temporary lifting equipment required
2.5	Pillars baseplates D02 (D03 side) n. 19	D02/D03	5	0	0	1	3	0,3	0	4,3	1	Forklift required.
2.6	Pillars baseplates D02 (D01 side) n. 19	D02/D01	5	0	0	1	3	0,3	0	4,3	1	Forklift required.
2.7	Pillars, beams frames and wall brackets in D02 (D03 side) (n. 19+28+6)	D02/D03	20	0	0	1	3	0,3	0	4,3	1	Forklift and boom lift required. Building cranes available
2.8	Pillars, beams frames and wall brackets D02 (D01 side) (n. 19+28+6)	D02/D01	20	0	0	1	3	0,3	0	4,3	1	Forklift and boom lift) required. Building cranes available
2.9	Pillars, beams and angular frames D03 (36+55+7)	D03	32	0	0	1	3	0,3	0	4,3	1	Forklift and boom lift for each team required. Building cranes available
2.10	Pillars, beams and angular frames D01 (n.9+13+2)	D01	8	0	0	1	3	0,3	0	4,3	1	Forklift and boom lift required. Building cranes available

# Resource plan: Bunker wall North/West sector

n.	TASK description	Area	Days	Resources (Labour)						Total	Team	Note
				Tech (Crane)	Tech (Rig)	Tech (Han)	Tech Mech	Eng (Metrol.)	Tech Electr	Labour	n.	
1	2	3	4	5	6	7	8	9	10	11	12	13

3	Installation of Bunker walls West/North sector (D03)											
3.1	North sector wall in D02 (D03 side) short sector n. 51 full spec + 39 concrete	D02/D03	18	1	1	0	2	0,2	0	4,2	1	Building cranes available
3.2	Side wall D03 - 54 blocks	D03	7	1	1	0	2	0,2	0	4,2	1	Building cranes available
3.3	West sector wall (D03) - long sector n. 136 full spec. + 16 concrete	D03	19	1	1	0	2	0,2	0	4,2	1	Building cranes available
3.4	Logistic support out of the Halls (from site storage-area to the working area)	SITE	44	1	0	1	0	0	0	2	1	Equipment (mobile crane, truck, n. 2 trailers) and support personnel to transport the blocks into the building from the site storage area (building cranes in the buildings available)



# Resource plan: Bunker wall South/West sector

n.	TASK description	Area	Days	Resources (Labour)						Total Labour	Team n.	Note
				Tech (Crane)	Tech (Rig)	Tech (Han)	Tech Mech	Eng (Metrol.)	Tech Electr			
1	2	3	4	5	6	7	8	9	10	11	12	13

4	Installation of Bunker walls East/South sector (D01)											
4.1	East sector wall D02 (D01 side) 21 full spec + 72 concrete	D02/D01	18	1	1	0	2	0,2	0	4,2	1	Building cranes available
4.2	Side wall D01 (n. 42)	D01	5	1	1	0	2	0,2	0	4,2	1	Building cranes available
4.3	South sector - D01 wall - long sector (34 full spec + 25 concrete)	D01	8	1	1	0	2	0,2	0	4,2	1	Building cranes available
4.4	Logistic support out of the Halls (from site storage-area to the working area)	SITE	31	1	0	1	0	0	0	2	1	Equipment (mobile crane, truck, n. 2 trailers) and support personnel to transport the blocks into the building from the site storage area (building cranes in the buildings available)

# Resource plan: Bunker roof, 1<sup>st</sup> layer

n.	TASK description	Area	Days	Resources (Labour)						Total	Team	Note
				Tech (Crane)	Tech (Rig)	Tech (Han)	Tech Mech	Eng (Metrol.)	Tech Electr	Labour	n.	
1	2	3	4	5	6	7	8	9	10	11	12	13

5	Installation of Bunker Roof -1st layer											
5.1	Bunker roof - 1st layer D02 (D03 side) and D03 - (43+44 blocks)	D02/D03	14	1	1	0	2	0	0	4	1	Building cranes available
5.2	Bunker roof - 1st layer D02 (D01 side) and D01 (n. 48 + 15 blocks)	D02/D01	11	1	1	0	2	0	0	4	1	Building cranes available
5.3	Logistic support out of the Halls (from site storage-area to the working area)	SITE	25	1	0	1	0	0	0	2	1	Equipment (mobile crane, truck, n2 flat bed trailers) and support personnel to transport the blocks into the building from the site storage area (building cranes in the buildings available)

# Resource plan: Bunker roof, 2<sup>nd</sup> and 3<sup>rd</sup> layer

n.	TASK description	Area	Days	Resources (Labour)						Total	Team	Note
				Tech (Crane)	Tech (Rig)	Tech (Han)	Tech Mech	Eng (Metrol.)	Tech Electr	Labour	n.	
1	2	3	4	5	6	7	8	9	10	11	12	13

6	Installation Bunker roof 2nd and 3rd layers)											
6.1	Bunker roof - 2nd and 3rd layer D02 (D03 side) and D03 (n. 84 + 88 blocks)	D02/D03	27	1	1	0	2	0	0	4	1	Building cranes available
6.2	Bunker roof - 2nd and 3rd layer D02 (D01 side) and D01 - (n. 96 +30 blocks)	D02/D01	22	1	1	0	2	0	0	4	1	Building cranes available
6.3	Logistic support out of the Halls (from site storage-area to the working area)	SITE	49	1	0	1	0	0	0	2	1	Equipment (mobile crane, truck, n. 2 trailers) and support personnel to transport the blocks into the building from the site storage area (building cranes in the buildings available)

# Resource plan: Utilities and PSS

n.	TASK description	Area	Days	Resources (Labour)						Total	Team	Note	
				Tech (Crane)	Tech (Rig)	Tech (Han)	Tech Mech	Eng (Metrol.)	Tech Electr	Labour	n.		
1	2	3	4	5	6	7	8	9	10	11	12	13	
7	Installation of Utilities and PSS												
7.1	Utilities installation D02 (D03 side) and D03	D02/D03	7	0,5	0,5	0	2	0	1	4	1	Forklift and boom lift required. Building cranes available	
7.2	Utilities installation D02 (D01 side) and D01	D02/D01	7	0,5	0,5	0	2	0	1	4	1	Forklift (and boom lift required. Building cranes available	
7.3	Installation of PSS on top of the Bunker roof D02 (D03 side) and D03	D02/D03	15	0,5	0,5	0	1	0	2	4	1	Forklift and boom lift required. Building cranes available	
7.4	Installation of PSS on top of the Bunker roof D02 (D01 side) and D01	D02/D01	15	0,5	0,5	0	0	0	3	4	1	Forklift and boom lift required. Building cranes available	
7.5	PSS commissioning before BoT		10	0	0	0	0	0	3	3	1	Forklift and boom lift required. Building cranes available	

# Questions

