



Document Type Description
Document Number ESS-0184371
Date 2017-11-09
Revision 1
Confidentiality Level Internal

DM--ID-TBSIDDH09-Basis for the H09 load plan.pdf

	Name	Role/Title
Owner	Tobias Hörnfeldt	Requirement engineer
Reviewer	Per Persson	Waste manager
	Andreas Abrahamsson	Structural Engineer
Approver	Boris Kildetoft	Building Owner

TABLE OF CONTENT

PAGE

Basis of load plan for level 090..... 3/8
Basis of load plan for level 100.....4/8
Basis of load plan for level 110.....5/8
Basis of load plan for level 115.....6/8
Basis of load plan for level 120.....7/8
Basis of LSC to be positioned in H09.100.1003.....8/8

LEGEND

SEE A03-40---1-H09100100

REFERENCES

- PLANS A03-40---1-H09090100 - 120
- SECTIONS A03-40---2-H09---001 - 004
- FACADES A03-40---3-H09---001 - 004
- SYSTEM DESCRIPTION H09
- SYSTEM REQUIREMENTS H09
- ARCHITECTURAL
- H09 TECHNICAL BASELINE ARCHITECTURAL

2017-10-18

REV	REVISION TYPE	DATE	SIGN
PRELIMINARY DESIGN			
ESS CONVENTIONAL FACILITIES			
H09 WASTE MANAGEMENT BUILDING			

ESS CONVENTIONAL FACILITIES
H09 WASTE MANAGEMENT BUILDING

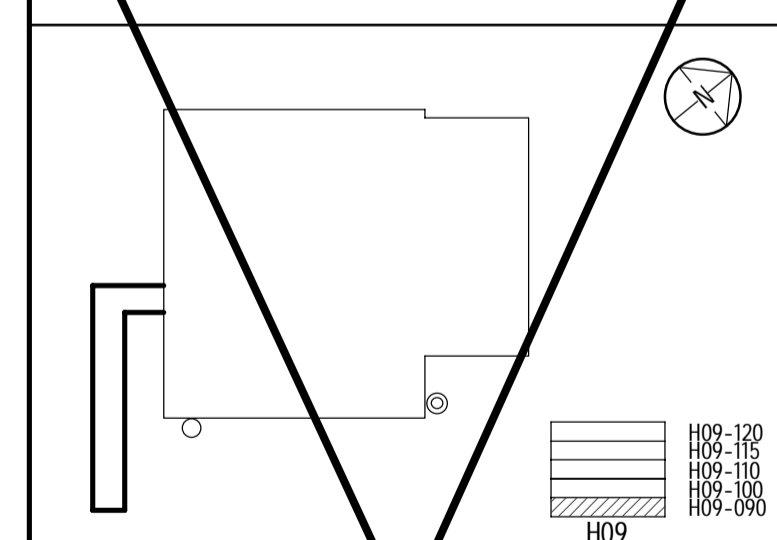

European Spallation Source ERIC
ESS, Tunavägen 24
P.O. Box 176
SE-221 00 Lund
SWEDEN
www.ess.se



DESIGN COORDINATOR	BORIS KILDETOFT
CONSULTANT	SWECO ARCHITECTS
PROJECT NUMBER	383221600
DRAWN BY	SEVITH
MANAGED BY	SESMAR
CHECKED BY	SEFSOF
DATE	
APPROVED BY	SESMAR

PLAN, LEVEL 090, ZONE 100, EXTERNAL
CULVERT

SCALE	A1 1:100
	A3 1:200
DRAWING NUMBER	A03-40---1-H09090100

1 REV

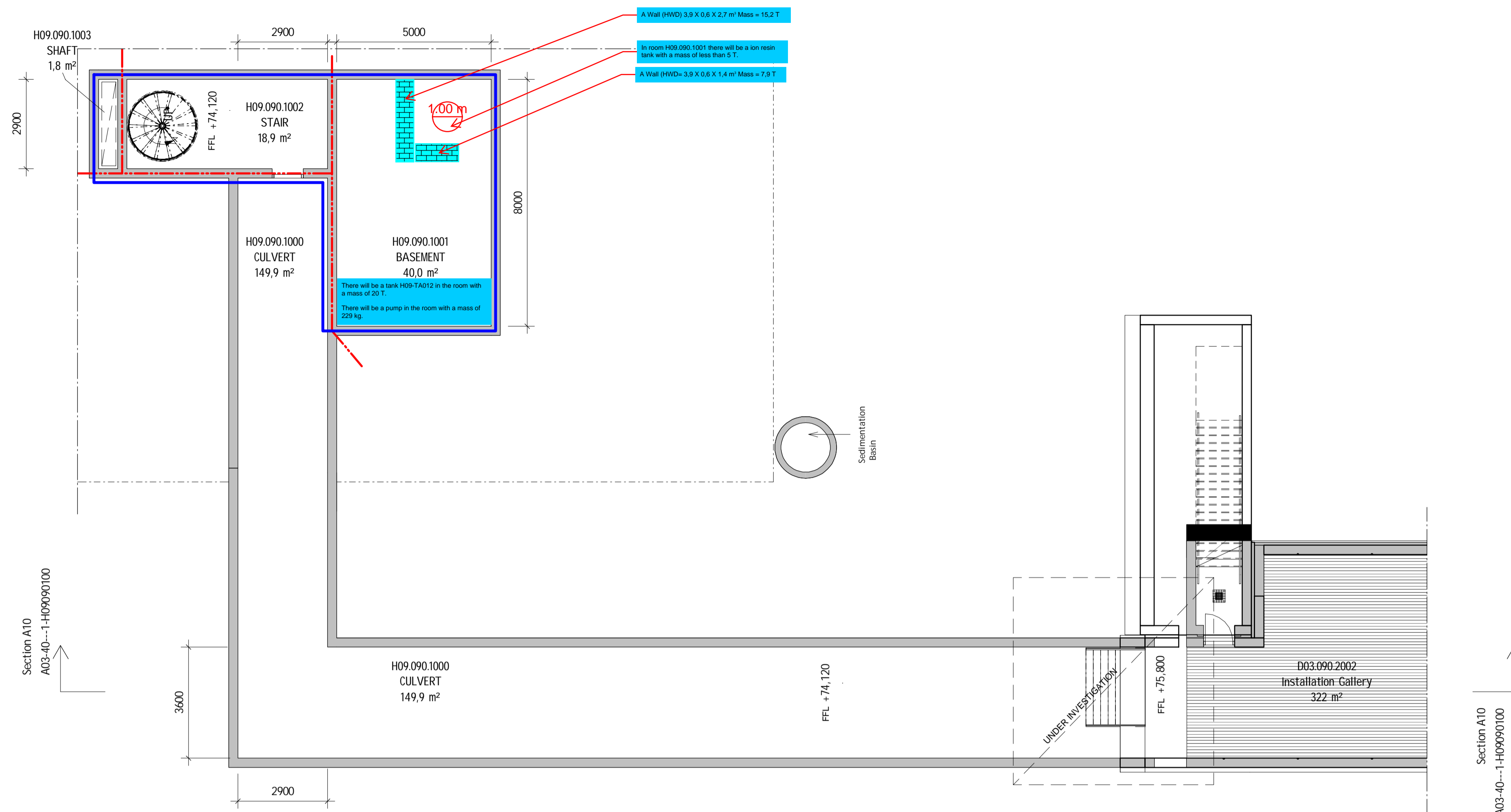

A40 H09-090 CULVERT

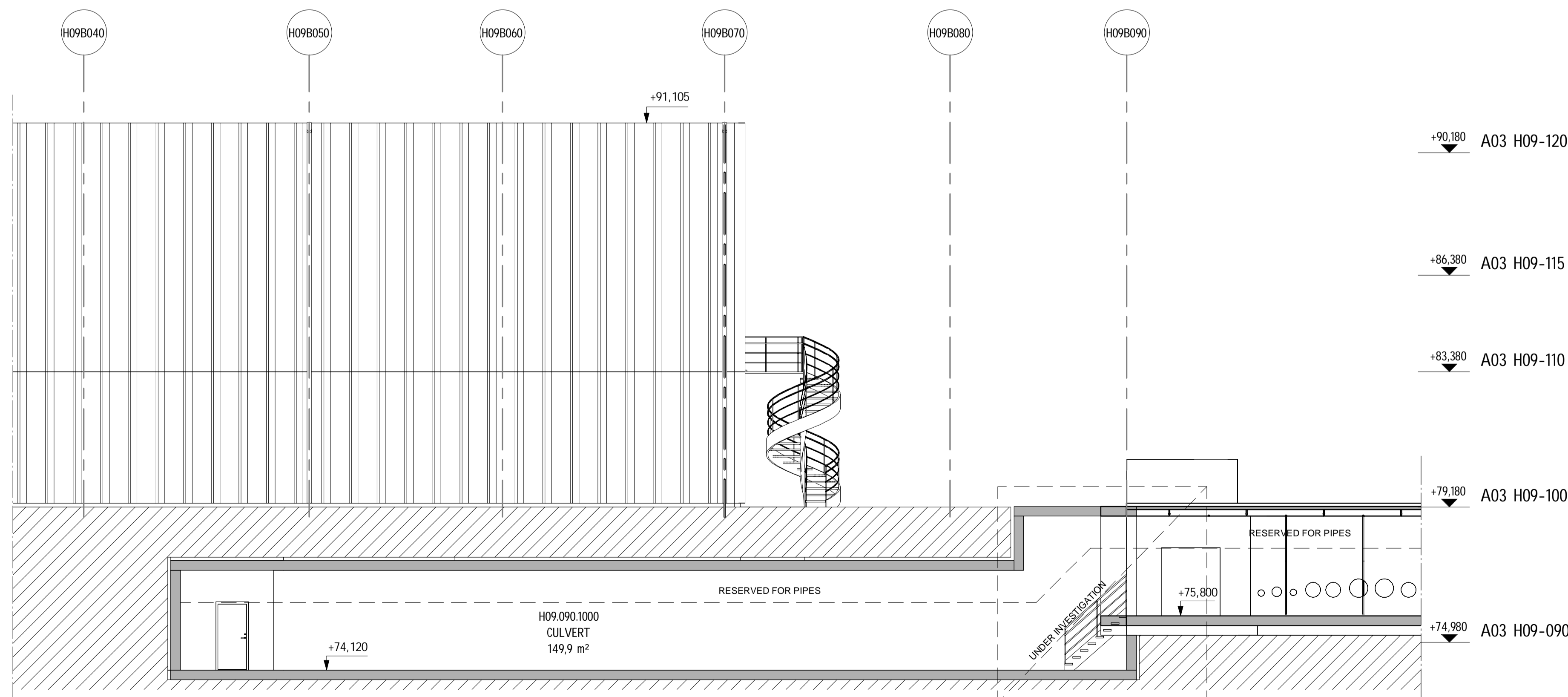

Section A10

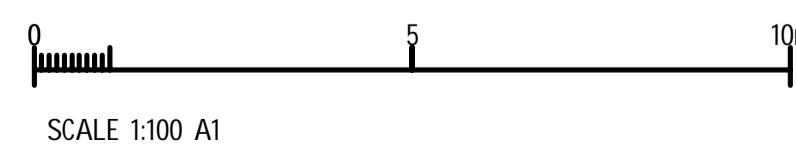

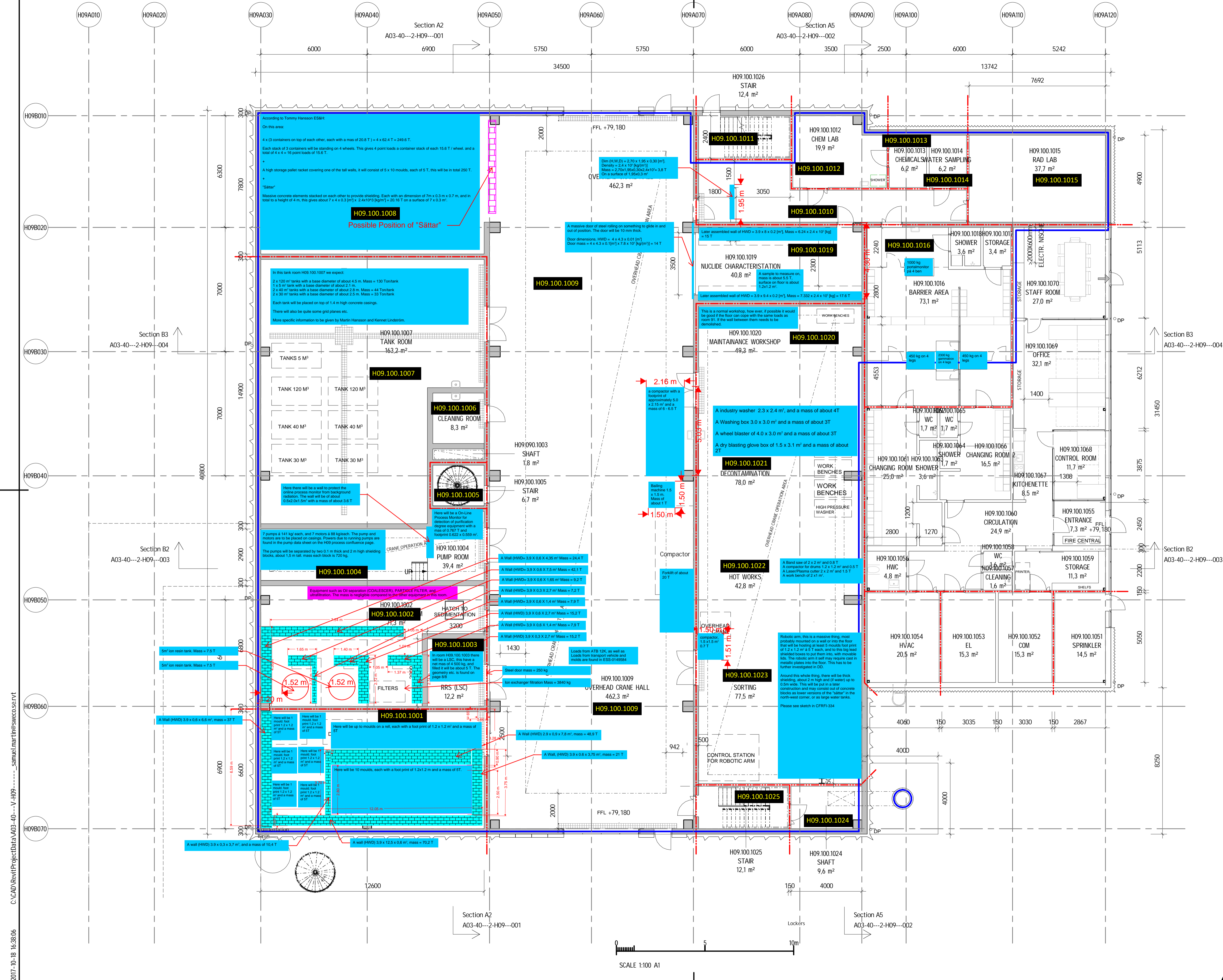

- ### LEGEND
- +XX.XXX FINISHED FLOOR LEVEL
 - SINGLE DOOR (H=2120MM UNLESS OTHERWISE IS STATED)
 - DOUBLE DOOR (H=2120MM UNLESS OTHERWISE IS STATED)
 - WX WALL NAME (X NUMBER)
 - CONCRETE WALL ACC. TO SE
 - NON-CONCRETE WALL
 - EMERGENCY EXIT
 - EI 60, FIRE COMPARTMENT
 - DOWN PIPE
 - FFL FINISHED FLOOR LEVEL
 - FLOOR DRAIN
 - CONTROLLED AREA
 - H09.XXX.XXXX ROOM NR (BUILDING LEVEL NR)
 - XXXXXXXXXX ROOM NAME
 - C11
 - C14
 - ALUCOBOND

- ### REFERENCES
- PLANS A03-40---1-H09090100 - 120
 - SECTIONS A03-40---2-H09---001 - 004
 - FACADES A03-40---3-H09---001 - 004
 - SYSTEM DESCRIPTION H09
 - SYSTEM REQUIREMENTS H09
 - ARCHITECTURAL
 - H09 TECHNICAL BASELINE ARCHITECTURAL

2017-10-18

REV	REVISION TYPE	DATE	SIGN

PRELIMINARY DESIGN

ESS CONVENTIONAL FACILITIES

H09 WASTE MANAGEMENT BUILDING

100

European Spallation Source ERIC
ESS, Tunavägen 24
P.O. Box 176
SE-221 00 Lund
SWEDEN
www.ess.se

DESIGN COORDINATOR: SWECO ARCHITECTS
CONSULTANT: SWECO ARCHITECTS
DRAWN BY: SEVITH
DATE:

BUILDING OWNER: BORIS KILDETOFT
PROJECT NUMBER: 383221600
MANAGED BY: SESMAR
CHECKED BY: SEFSOF
APPROVED BY: SESMAR

PLAY LEVEL 100, ZONE 100

SCALE: A1 1:100
A3 1:200
DRAWING NUMBER:

A03-40---1-H09100100

C:\CAD\Revit\ProjectData\A03-40---1-H09---V-H09---ssemuel.martinsweco.se.rvt

LEGEND

SEE A03-40---1-H09100100

REFERENCES

- PLANS A03-40---1-H09090100 - 120
- SECTIONS A03-40---2-H09---001 - 004
- FACADES A03-40---3-H09---001 - 004
- SYSTEM DESCRIPTION H09
- SYSTEM REQUIREMENTS H09
- ARCHITECTURAL
- H09 TECHNICAL BASELINE ARCHITECTURAL

2017-10-18

REV	REVISION TYPE	DATE	SIGN
PRELIMINARY DESIGN			
ESS CONVENTIONAL FACILITIES			
H09 WASTE MANAGEMENT BUILDING			
European Spallation Source ERIC ESS, Tunavägen 24 P.O. Box 176 SE-221 00 Lund SWEDEN www.ess.se			
DESIGN COORDINATOR		BUILDING OWNER	
SWECO ARCHITECTS		BORIS KILDETOFT	
CONSULTANT		PROJECT NUMBER	
SEVITH		83221600	
DRAWN BY		CHECKED BY	
SEVITH		SEMAR	
DATE		APPROVED BY	
		SEMAR	

PLAN LEVEL 110, ZONE 100

SCALE	1:100	DRAWING NUMBER	1 REV
	1:200		

A03-40---1-H09110100

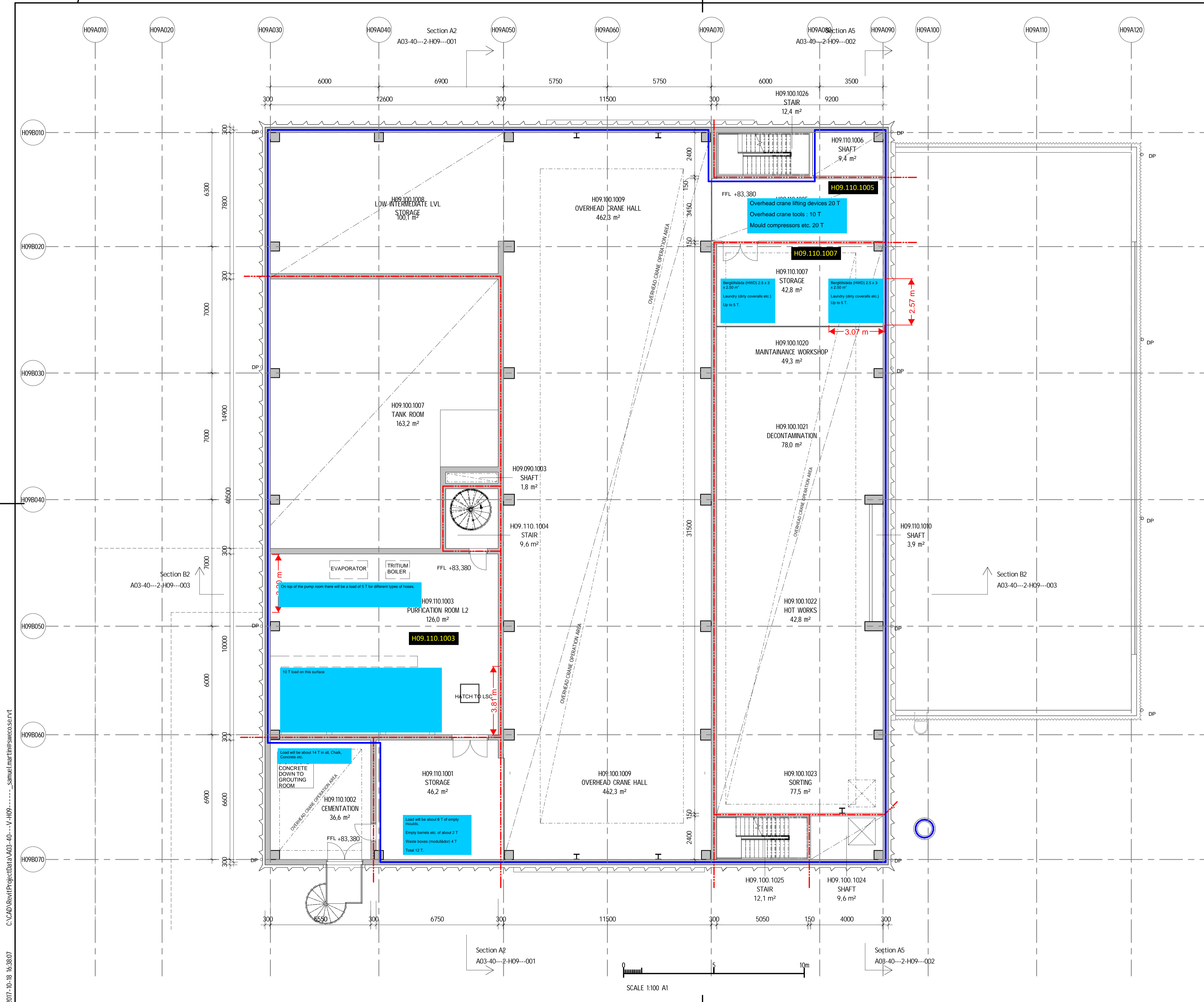

C:\CAD\Revit\ProjectData\A03-40---1-H09---001---V-H09---001---ssemuel.martins@sweco.se.rvt

2017-10-18 16:38:07

C:\CAD\New\ProjectData\A03-40---V-H09---..._samuel.martins@sweco.se.rvt
2017-10-18 16:38:07

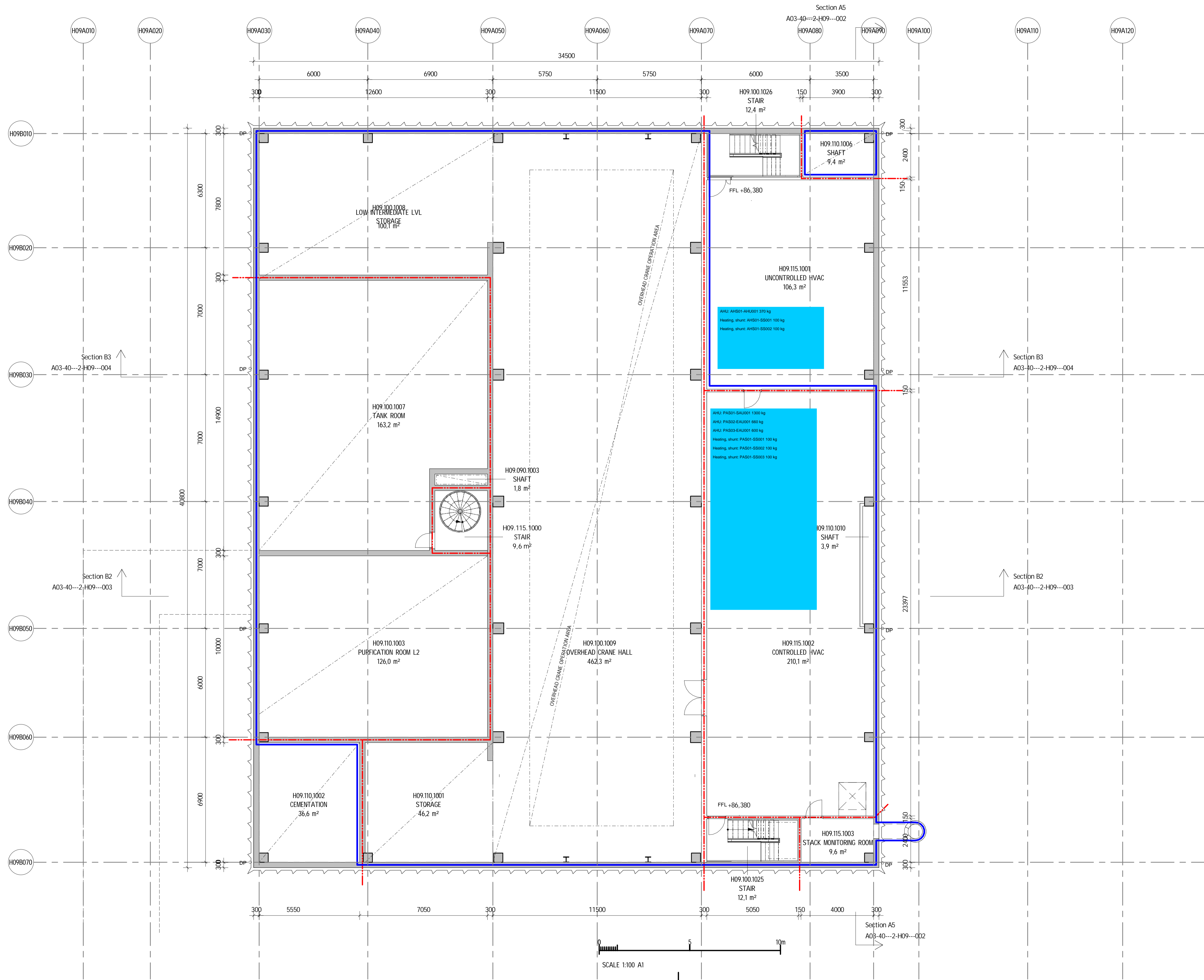

LEGEND

SEE A03-40---1-H09100100

REFERENCES

- PLANS A03-40---1-H09090100 - 120
- SECTIONS A03-40---2-H09---001 - 004
- FACADES A03-40---3-H09---001 - 004
- SYSTEM DESCRIPTION H09
- SYSTEM REQUIREMENTS H09
- ARCHITECTURAL
- H09 TECHNICAL BASELINE ARCHITECTURAL

2017-10-18

REV	REVISION TYPE	DATE	SIGN
PRELIMINARY DESIGN			
ESS CONVENTIONAL FACILITIES			
H09 WASTE MANAGEMENT BUILDING			
<p>European Spallation Source ERIC ESS, Tunavägen 24 P.O. Box 176 SE-221 00 Lund SWEDEN www.ess.se</p>			
DESIGN COORDINATOR		BUILDING OWNER	
		BORIS KILDETOFT	
CONSULTANT		PROJECT NUMBER	
SWECO ARCHITECTS		383221600	
DRAWN BY	MANAGED BY	CHECKED BY	
SEVITH	SESMAR	SEFSOF	
DATE	APPROVED BY		
	SESMAR		
PLAN, LEVEL 115, ZONE 100			
SCALE			
A1 1:100			
A2 1:200			
DRAWING NUMBER	1 RE		
A03-40---1-H09115100			

C:\CAD\Revit\ProjectData\A03-40---V-H09-----_samuel.martins@sweco.se.rvt
2017-10-18 16:38:08

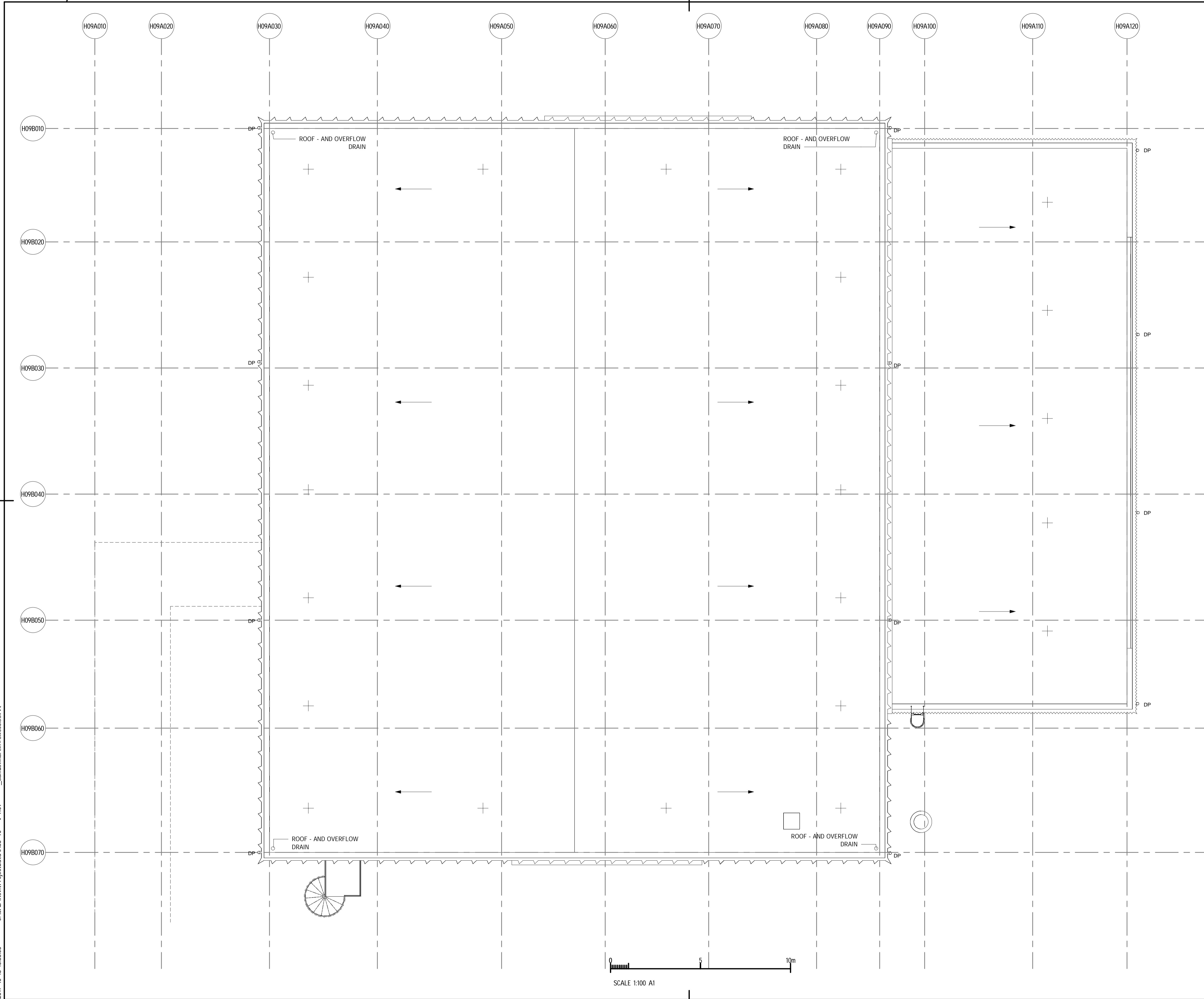

LEGEND

- DP
- SLOPE DOWN
- + LIFELINE FIXTURE

REFERENCES

PLANS A03-40---1-H09090100 - 120
 SECTIONS A03-40---2-H09---001 - 004
 FACADES A03-40---3-H09---001 - 004
 SYSTEM REQUIREMENTS H09
 ARCHITECTURAL
 H09 TECHNICAL BASELINE ARCHITECTURAL

2017-10-18

REV	REVISION TYPE	DATE	SIGN
PRELIMINARY DESIGN			
ESS CONVENTIONAL FACILITIES			
H09 WASTE MANAGEMENT BUILDING			
European Spallation Source ERIC ESS, Tunavägen 24 P.O. Box 176 SE-221 00 Lund SWEDEN www.ess.se			
DESIGN COORDINATOR		BUILDING OWNER	
		BORIS KILDETOFT	
CONSULTANT		PROJECT NUMBER	
SWECO ARCHITECTS		83221600	
DRAWN BY	MANAGED BY	CHECKED BY	
SEVITH	SESMAR	SEFSOF	
DATE	APPROVED BY		
	SESMAR		
PLAN, LEVEL 120, ZONE 100			
SCALE			
A1 1:100			
A3 1:200			
DRAWING NUMBER			REV
A03-40---1-H09120100			1

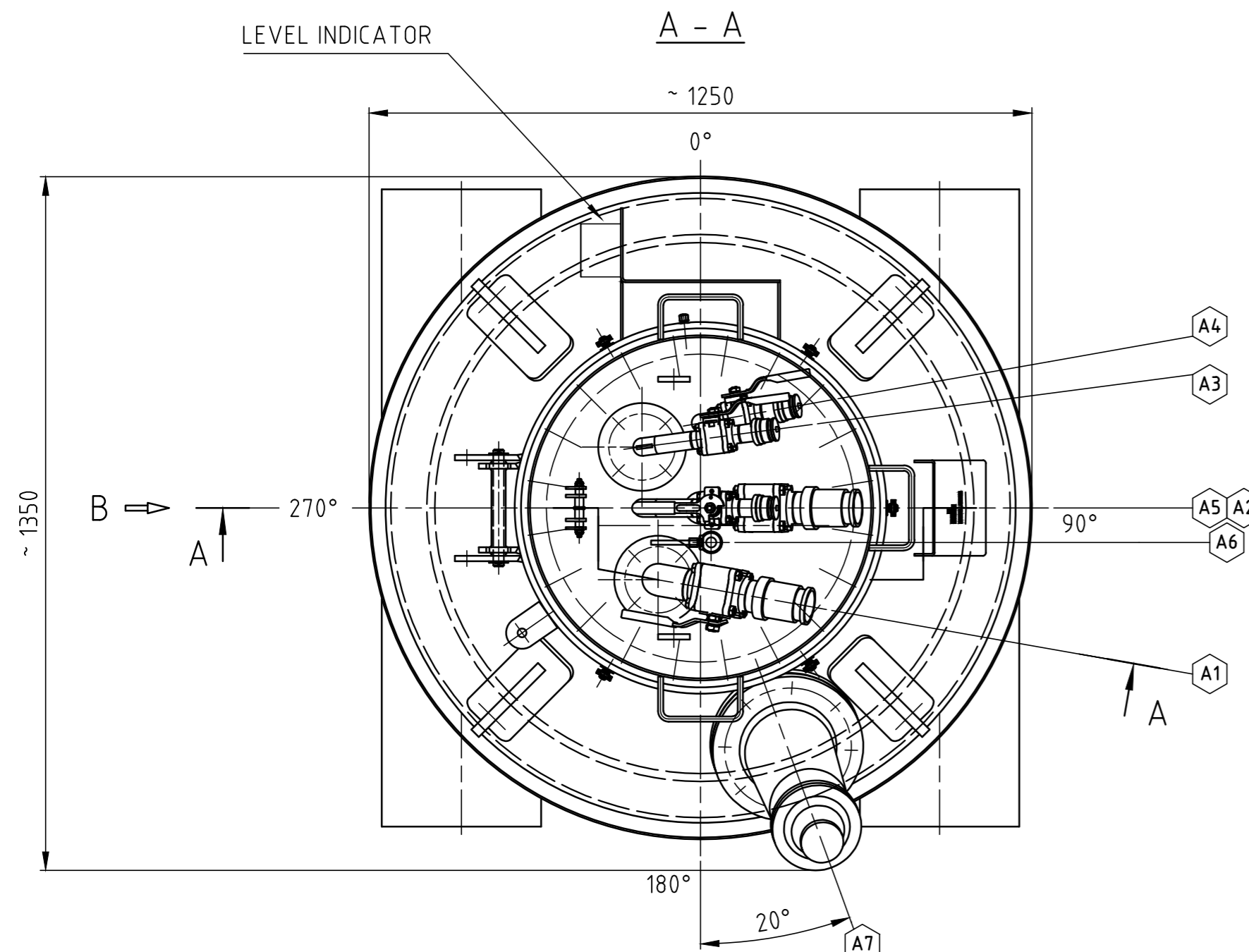
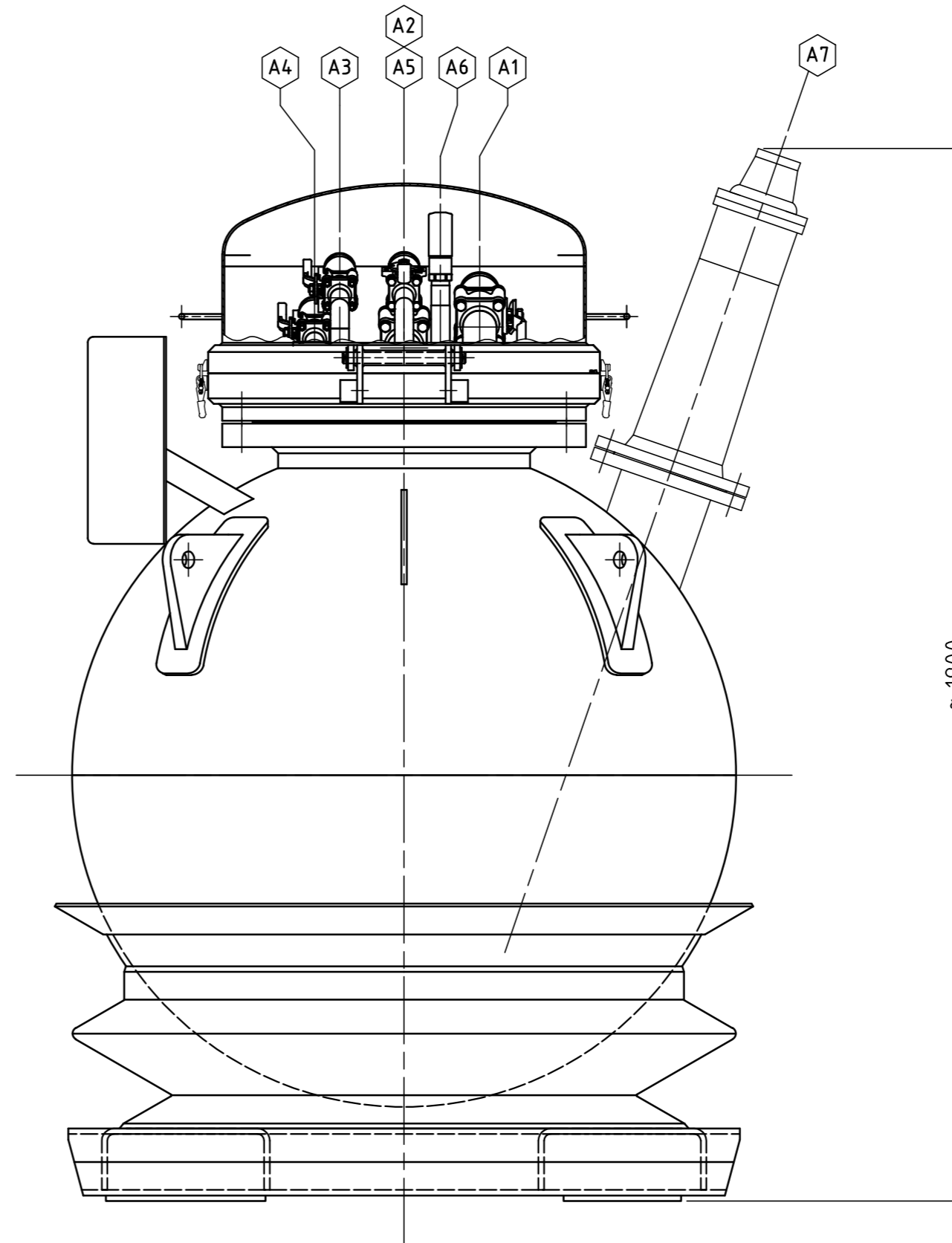
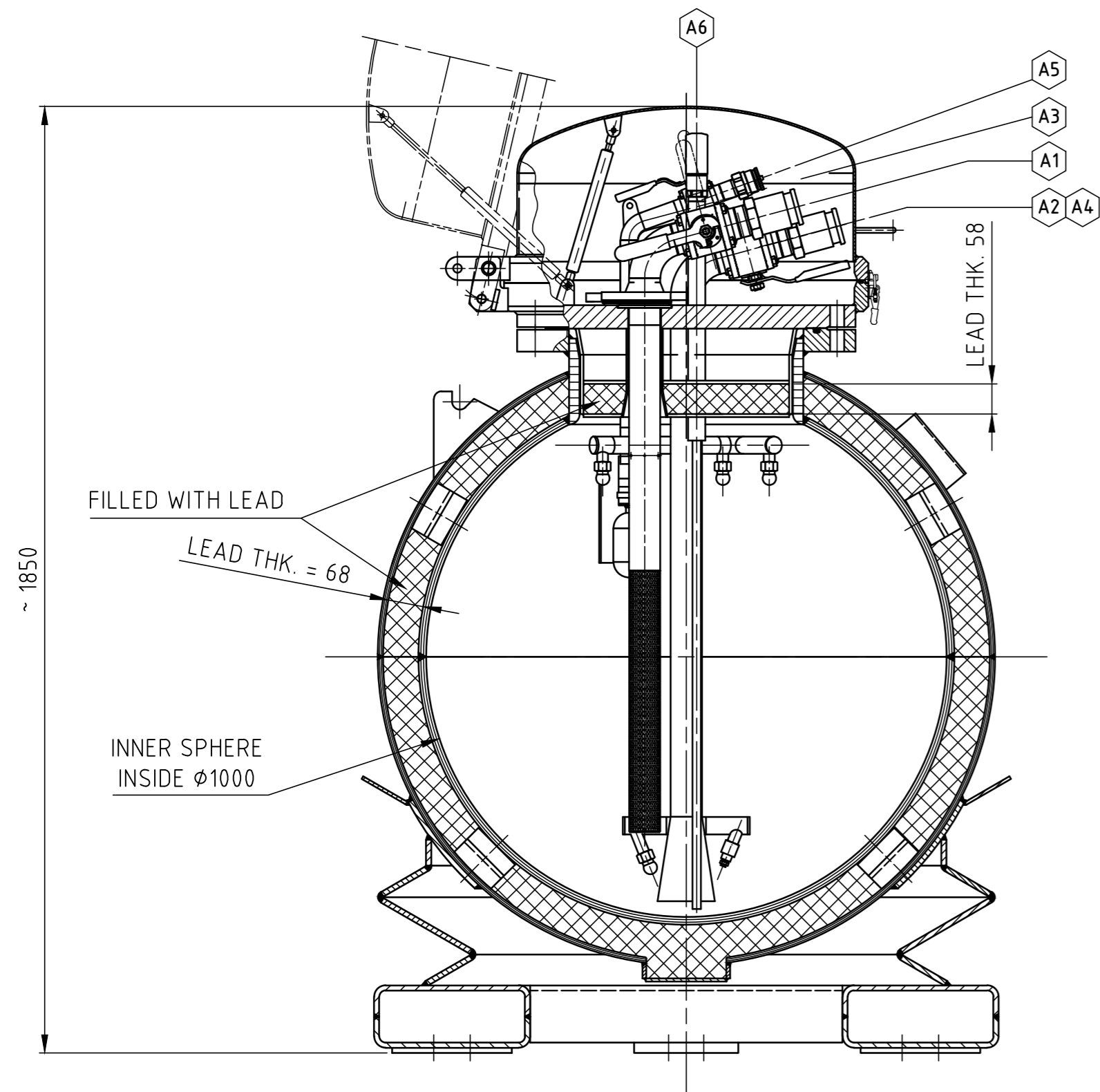

DESIGN DATA	
BERÄKNINGSTRYCK DESIGN PRESSURE	10 bar(g) / F.V.
BERÄKNINGSTEMPERATUR DESIGN TEMPERATURE	0°C / 60°C
INVÄNDIG VOLYM INTERNAL VOLUME	500 L
GEN. KVALITETS KRAV GENERAL QUALITY REQ.	KBM edition 6 (Swedish)
KVALITETSKLASS QUALITY CLASS	4 A
SÄKERHETSKLASS SECURITY CLASS	4
TÄTNINGSKlass TIGHTNESS CLASS	S
BESIKTNINGSKlass INSPECTION CLASS	AFS 2005:3 CLASS A
SVETSKVALITETSNIVÅ WELDING QUALITY LEVEL	EN ISO 5817 CLASS B

A7	1	150	AGITATOR/MIXER WITH AIR MOTOR
A6	1	R1"	LEVEL CONTROL
A5	1	25	FLUSH WATER, AIR
A4	1	25	AIR MIXING
A3	1	25	VACUUM
A2	1	50	EMPTYING
A1	1	50	FILLING
MARK	QTY.	ND	SERVICE

NOZZLE CONNECTIONS

ESTIMATED WEIGHTS			
NETTO VIKT FABRICATED WEIGHT	4500 Kg	PROVTRYCKNINGSVIKT TEST WEIGHT	5000 Kg

BTRI Sweden AB
 Container for transport of radioactive material/sludge
 Outline sketch



2015-06-04 HT | 1:10 / A2

BTRI-150402-DWG-0